

M2.5 × 16mm Cheese Head Screw

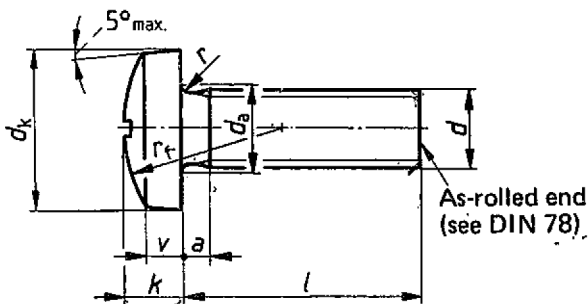

Dimensions

Raised cheese head screw,
threaded up to the head



Raised cheese head screw, with
unthreaded portion of shank ¹

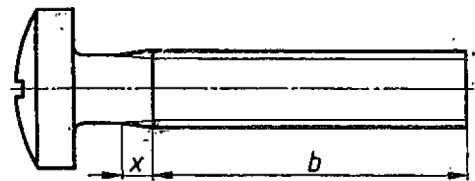

Other dimensions and details as in left-hand illustration

The shank diameter may be equal to the thread diameter (major diameter) (normal shank) or approximately equal to the pitch diameter (reduced shank), at the manufacturer's discretion.

Cross recess type H

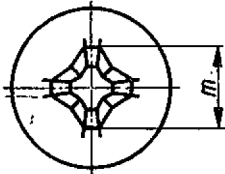

Cross recess type Z

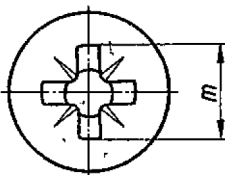

¹) If raised cheese head screws are to be supplied with lengths as given below the stepped line and threaded up to the head, i.e. deviating from the standard design, then symbol A is to be incorporated in the designation in accordance with DIN 962, or the deviating thread length is to be included in the designation, again in accordance with DIN962 (the tolerance on the thread length being normally $+^2_0P$).



M2.5 × 16mm Cheese Head Screw



Thread size <i>d</i>		M2.5	
<i>P</i> 1		0.45	
<i>a</i>	max.	0.9	
<i>b</i>	$+^2_0 P$	18	
<i>da</i>	max.	3.1	
<i>dk</i>	max.=nominal dimension	5	
	min.	4.7	
<i>k</i>	Nominal dimension	2	
	max.	2.12	
	min	1.88	
<i>r</i>	min	0.1	
<i>rf</i>	≈	5	
<i>v</i>	≈	1.3	
<i>x</i>	max.	1.1	
Cross recess	No.	1	
	Type H	<i>m</i>	≈ 2.7
		penetration depth	min. 1.3 max. 1.6
	Type Z	<i>m</i>	≈ 2.6
		penetration depth	min. 1.27 max. 1.52

Nominal dimension	Min.	Max.	Mass (7.85 kg/dm ³), in Kg per 1,000 units, approximately
16	15.65	16.35	0.73

The screws are, as a general rule, manufactured in the sizes for which the mass has been given (for guidance only). Bracketed sizes should be avoided as far as possible.

Lengths exceeding 60mm shall be graded in steps of 10mm

1) *P* = pitch of thread.

Part Number Table

Description	Part Number
Screw, Cheese, M2.5 × 16mm, BZP, PK100	D02300

Important Notice : This data sheet and its contents (the "Information") belong to the members of the Premier Farnell group of companies (the "Group") or are licensed to it. No licence is granted for the use of it other than for information purposes in connection with the products to which it relates. No licence of any intellectual property rights is granted. The Information is subject to change without notice and replaces all data sheets previously supplied. The Information supplied is believed to be accurate but the Group assumes no responsibility for its accuracy or completeness, any error in or omission from it or for any use made of it. Users of this data sheet should check for themselves the Information and the suitability of the products for their purpose and not make any assumptions based on information included or omitted. Liability for loss or damage resulting from any reliance on the Information or use of it (including liability resulting from negligence or where the Group was aware of the possibility of such loss or damage arising) is excluded. This will not operate to limit or restrict the Group's liability for death or personal injury resulting from its negligence. DURATOOL is the registered trademark of the Group. © Premier Farnell plc 2012.

