

Renesas Demonstration Kit (RDK) for RX63N
User's Manual: Hardware
V1.0

RENESAS MCU
RX Family / RX600 Series / RX63N Group

All information contained in these materials, including products and product specifications, represents information on the product at the time of publication and is subject to change by Renesas Electronics Corp. without notice. Please review the latest information published by Renesas Electronics Corp. through various means, including the Renesas Electronics Corp. website (<http://www.renesas.com>).

Disclaimer

By using this Renesas Demonstration Kit (RDK), the user accepts the following terms. The RDK is not guaranteed to be error free, and the User assumes the entire risk as to the results and performance of the RDK. The RDK is provided by Renesas on an "as is" basis without warranty of any kind whether express or implied, including but not limited to the implied warranties of satisfactory quality, fitness for a particular purpose, title and non-infringement of intellectual property rights with regard to the RDK. Renesas expressly disclaims all such warranties. Renesas or its affiliates shall in no event be liable for any loss of profit, loss of data, loss of contract, loss of business, damage to reputation or goodwill, any economic loss, any reprogramming or recall costs (whether the foregoing losses are direct or indirect) nor shall Renesas or its affiliates be liable for any other direct or indirect special, incidental or consequential damages arising out of or in relation to the use of this RDK, even if Renesas or its affiliates have been advised of the possibility of such damages.

Precautions

This Renesas Demonstration Kit is only intended for use in a laboratory environment under ambient temperature and humidity conditions. A safe separation distance should be used between this and any sensitive equipment. Its use outside the laboratory, classroom, study area or similar such area invalidates conformity with the protection requirements of the Electromagnetic Compatibility Directive and could lead to prosecution.

The product generates, uses, and can radiate radio frequency energy and may cause harmful interference to radio communications. However, there is no guarantee that interference will not occur in a particular installation. If this equipment causes harmful interference to radio or television reception, which can be determined by turning the equipment off or on, you are encouraged to try to correct the interference by one or more of the following measures:

- Ensure attached cables do not lie across the equipment
- Reorient the receiving antenna
- Increase the distance between the equipment and the receiver
- Connect the equipment into an outlet on a circuit different from that which the receiver is connected
- Power down the equipment when not in use
- Consult the dealer or an experienced radio/TV technician for help NOTE: It is recommended that wherever possible shielded interface cables should be used.

The product is potentially susceptible to certain EMC phenomena. To mitigate against them it is recommended that the following measures be undertaken:

- The user is advised that mobile phones should not be used within 10m of the product when in use.
- The user is advised to take ESD precautions when handling the equipment.

The Renesas Demonstration Kit does not represent an ideal reference design for an end product and does not fulfill the regulatory standards for an end product.

Table of Contents

Chapter 1. Preface	1
Chapter 2. Purpose	2
Chapter 3. Power Supply	4
3.1. Requirements	4
3.2. Power – Up Behavior	4
Chapter 4. Board Layout	5
4.1. Board Layout	5
4.2. Board Dimensions	6
Chapter 5. Block Diagram	7
Chapter 6. User Circuitry	9
6.1. Pushbutton Switches	9
6.2. Debug LCD Module	9
6.3. LEDs	10
6.4. 3 – Axis Accelerometer	11
6.5. Digital Temp Sensor	11
6.6. Micron Serial Flash	11
6.7. MicroSD Memory Card Slot	11
6.8. Potentiometer	11
6.9. Serial port	11
6.10. Reset Circuit	12
6.11. Audio (Audio Out, Mic, Speaker)	12
6.12. RCAN	12
6.13. USB	13
6.14. Ethernet	14
6.15. Option Links and Jumper Settings	15
6.16. Oscillator Sources	18

6.17. Total Phase Beagle Debug Header	18
Chapter 7. RX63N Operating Modes	19
Chapter 8. Programming Methods.....	20
Chapter 9. Headers.....	21
9.1. Extension Header 1	21
9.2. Extension Header 2	22
9.3. Application Header.....	23
9.4. PMOD™ Interfaces	24
Chapter 10. Code Development	25
10.1. Overview	25
10.2. Compiler Restrictions	25
10.3. Breakpoint Support	25
10.4. Memory Map	26
Chapter 11. Component Placement	27
Chapter 12. Additional Information	28
12.1. Hardware Partner Information	28
Renesas Contact Information	40

Chapter 1. Preface

Cautions

This document may be, wholly or partially, subject to change without notice.

All rights reserved. The RDK design, documentation, and demo software are intended to improve understanding and time-to-market for RX63N-based designs. Duplication of the design, documentation, and demonstration software is encouraged.

Trademarks

All brand or product names used in this manual are trademarks or registered trademarks of their respective companies or organizations.

Copyright

© 2012 Renesas Electronics America, Inc. All rights reserved.

© 2012 Renesas Electronics Corporation. All rights reserved.

© 2012 Renesas Solutions Corporation. All rights reserved.

© 2012 Renesas Electronics Europe. All rights reserved.

Website: <http://www.renesas.com/>

Glossary

ADC	Analog to Digital Converter	MCU	Microcontroller Unit
CPU	Central Processing Unit	NC	No Connection
DAC	Digital to Analog Converter	PC	Program Counter
EMC	Electromagnetic compatibility	RAM	Random Access Memory
ESD	Electrostatic Discharge	RCAN	Renesas Controller Area Network
HEW	High-performance Embedded Workshop	ROM	Read-Only Memory
I/O	Input / Output	RDK	Renesas Demonstration Kit
LCD	Liquid Crystal Display	SDRAM	Synchronous Dynamic Random Access Memory
LED	Light Emitting Diode		

Chapter 2. Purpose

This RDK is an evaluation and demonstration tool for Renesas RX63N microcontrollers. The goal is to provide the user with a powerful debug and demonstration platform targeted at common applications. A set of human/machine interfaces are tightly integrated with the features of the RX63N and the software demonstration programs providing the user with an accessible platform to rapidly evaluate and customize.

Target Applications and Features:

- Audio
 - Stereo audio driver connected to the PWM interface
 - On-board microphone to demonstrate sampling, FFT/FPU capabilities
 - Volume Control Potentiometer
 - Micro SD card interface for audio and data files
- Motor Control
 - 3 – Phase motor control algorithm representation with LEDs
 - Motor control algorithm speed variation through volume control potentiometer
- Gaming
 - 3 – Axis Accelerometer (Digital)
 - User pushbutton switches
- Communications
 - 10/100 Ethernet Interface connected to an internal Ethernet MAC (1588 compatible)
 - USB Interface connected to an internal USB controller (Host, Device and OTG)
 - RS-232 Interface
 - CAN Interface
 - I2C, SPI with Debug through the Beagle connector from Total Phase
 - PMOD connections to support a variety of generic PMOD devices (WiFi, Bluetooth, RF, and much more).
- User Code and Application Debugging
 - On-board J-Link OB for high-quality source code debugging

Develop and submit your sample programs to demonstrate these features to the online community: www.RenesasRulz.com/RX63N

The Renesas RDK user experience is complemented by the online Renesas ecosystem:

- Renesas Interactive: www.RenesasInteractive.com
 - Free Online Learning
- Renesas Rulz: www.RenesasRulz.com
 - Online community
 - Online user forums
 - www.RenesasRules.com/RX63N - Online support site for this RDK
- University Program: www.RenesasUniversity.com
 - Support for Professors and Students
 - Support for University Kits (QSKs)
- Renesas Microcontroller Samples (America Customers)
 - Free of charge
 - Request directly from www.America.Renesas.com/samples

Chapter 3. Power Supply

3.1. Requirements

This RDK gets its power from the Segger J-Link OB USB connection or optionally from a regulated 5V power supply. The optional power jack is a center positive connector using a 2.1 mm barrel.

Warning: The RDK is neither under nor over-voltage protected. Use a 5v REGULATED center positive supply which can source at least 1 Amp.

3.2. Power – Up Behavior

The factory demo is based on two partner technologies:

- Micrium's RTOS kernel (uCOS-III), TCP-IP and HDCP networking stacks.
- Exosite's networked embedded systems and portal technology providing the cloud connectivity.

To boot up the factory demo:

- Read the enclosed Exosite QSG
- Install the factory DVD (version 1.0), included all provided drivers (JLINK).
- Connect Ethernet cable to the RDK and your LAN connection
- Connect the mini-USB cable to the JLink port, this will provide the debug link but also power (5 volts).
- Watch the board boot-up sequence, displaying the board MAC address, IP address and cloud status.
- The MAC address should match the address printed on the MAC Address sticker (right of the LCD display)
- Register your board and address thru the Exosite portal website.
- See your cloud status being updated to "connected".
- You are now ready to control your board through the Exosite portal.

Chapter 4. Board Layout

4.1. Board Layout

The following diagram shows the top layer component layout.

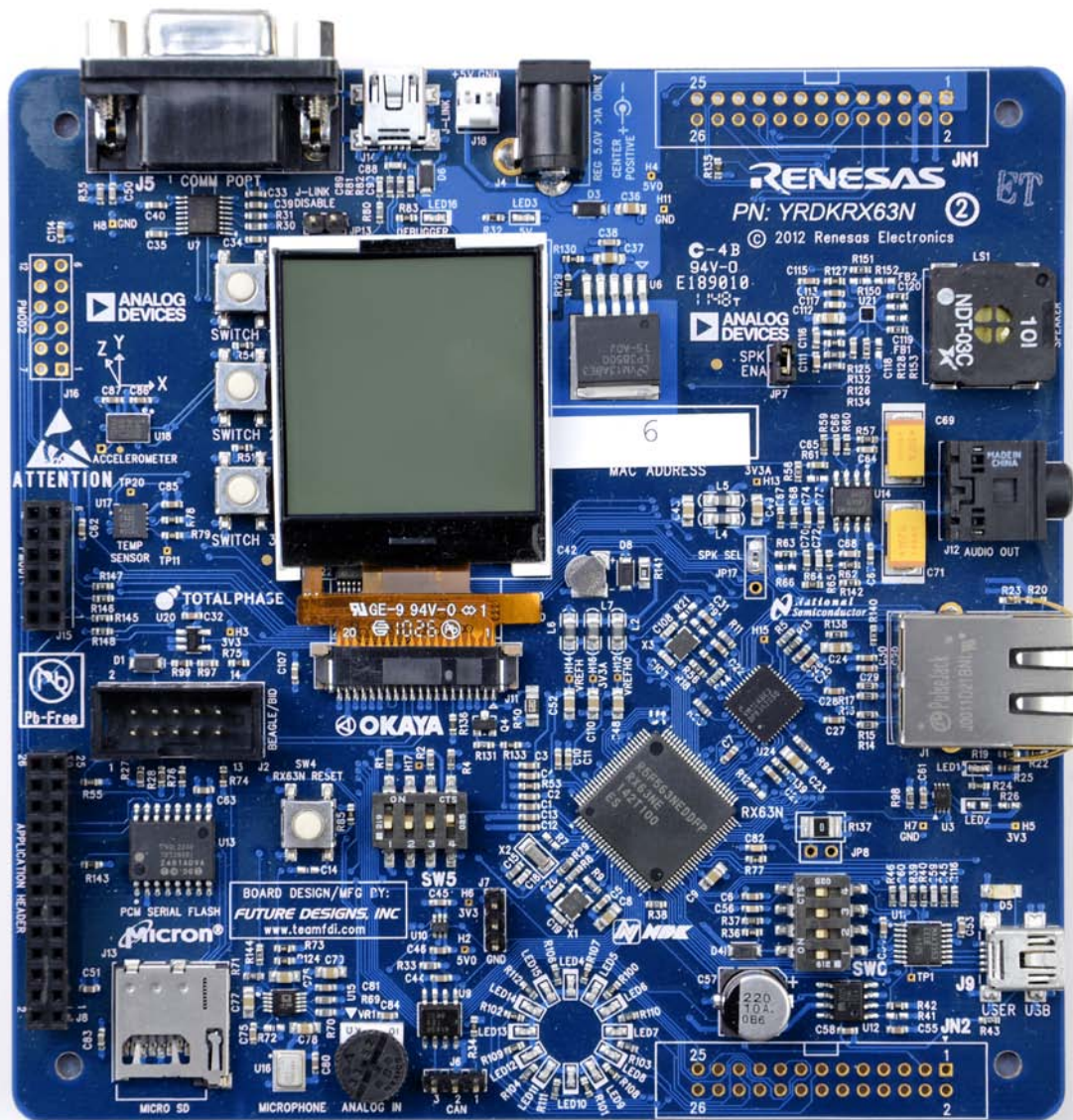

Figure 4-1: Board Layout

4.2. Board Dimensions

The following diagram gives the board dimensions and connector positions. All through hole connectors are on a common 0.1" grid for easy interfacing.

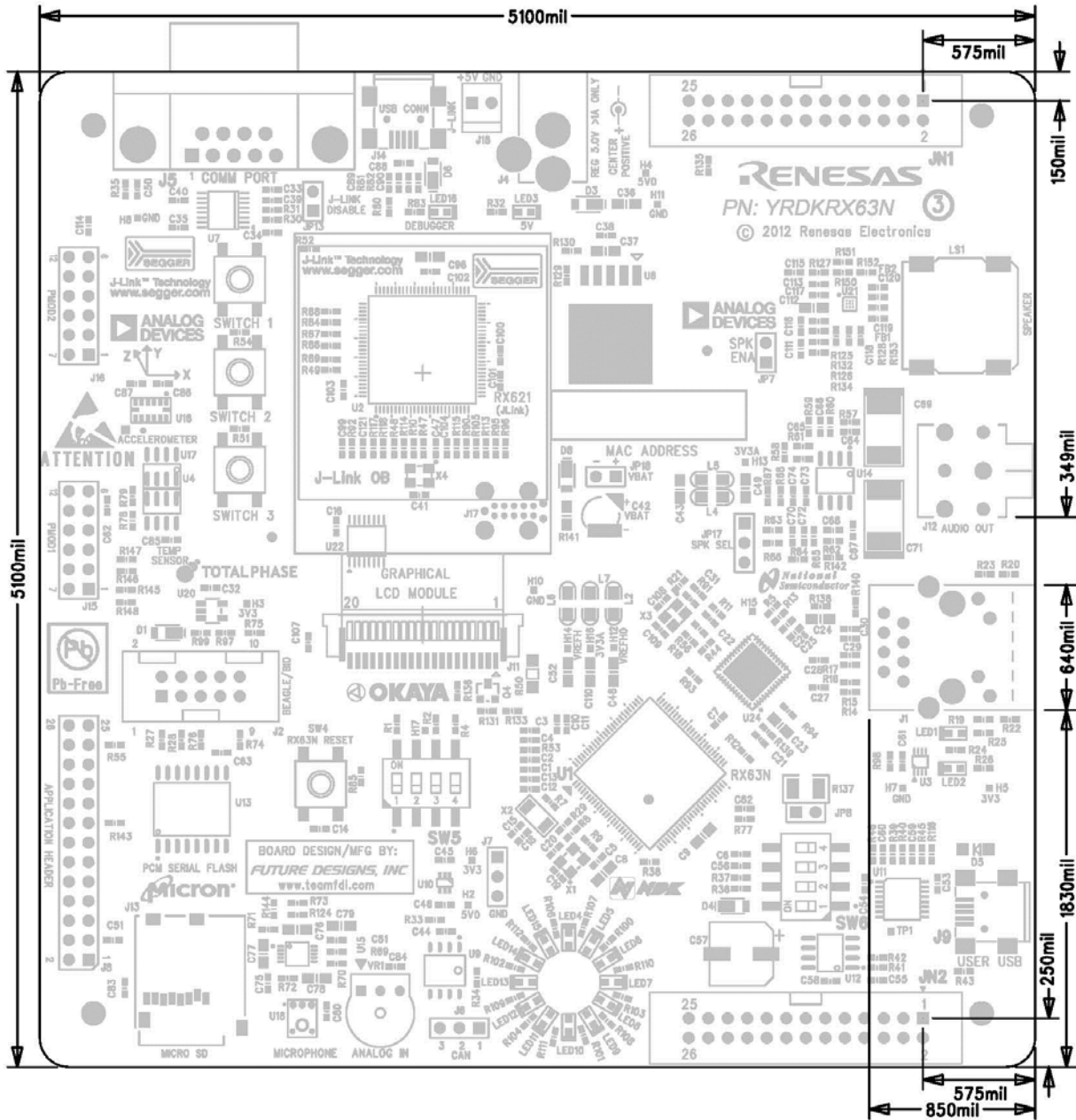

Figure 4-2: Board Dimensions

Chapter 5. Block Diagram

Figure 5-1 shows the CPU board components and their connectivity.

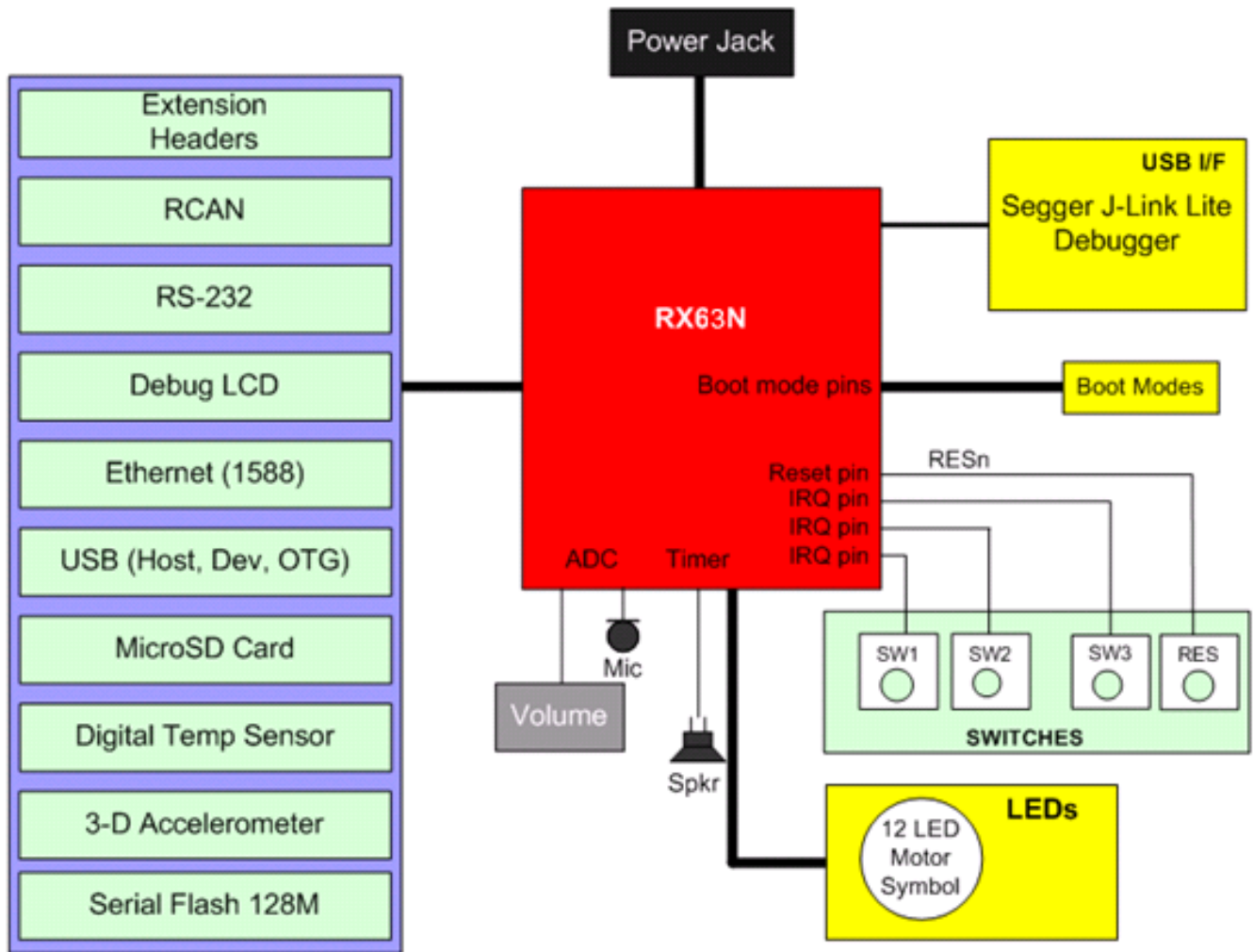

Figure 5-1: Block Diagram

Figure 5-2 shows host PC connection to the RDK board.

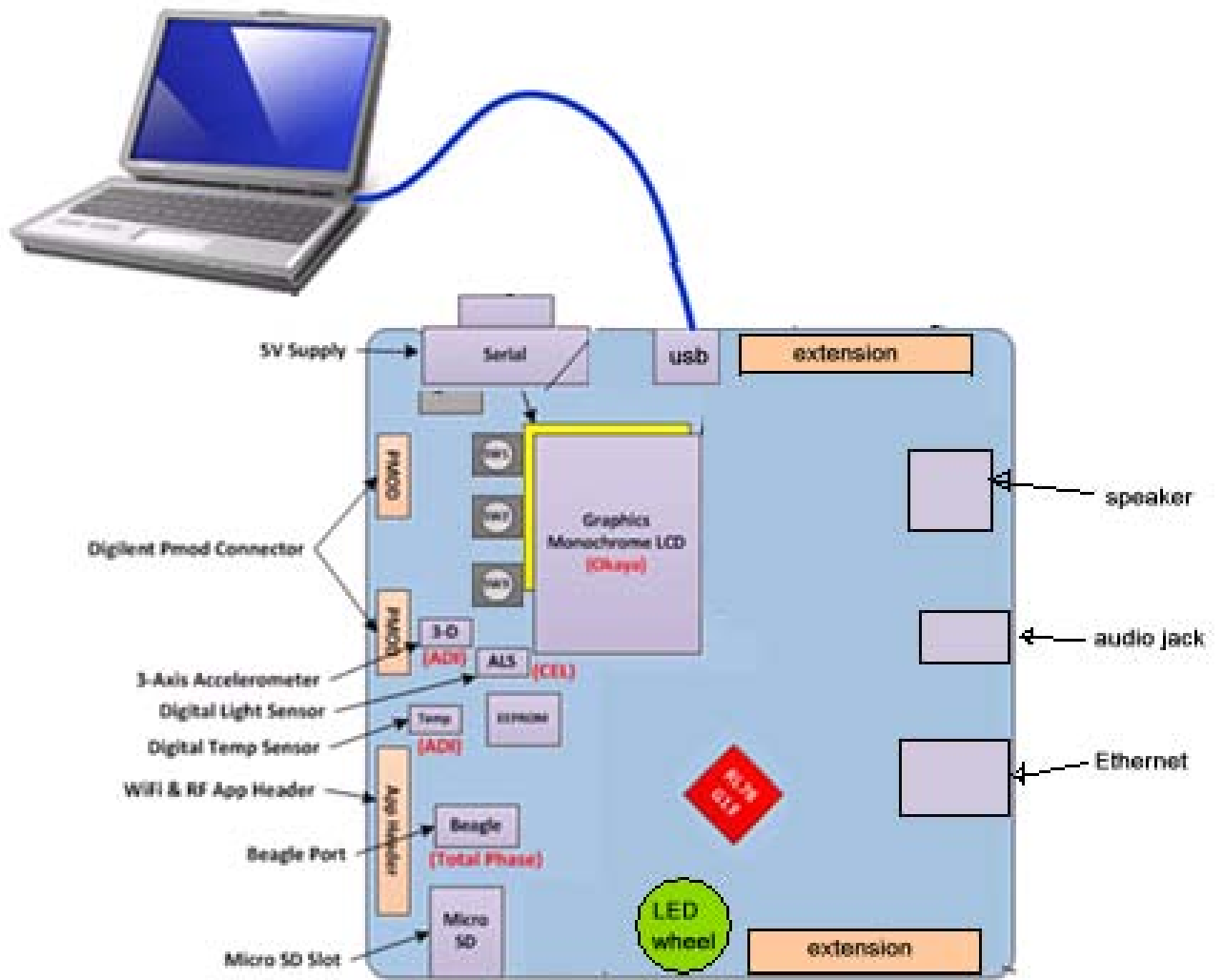

Figure 5-2: RDK Connections

Chapter 6. User Circuitry

6.1. Pushbutton Switches

There are five pushbutton switches located on the CPU board. **Table 6-1** shows the function of each pushbutton switch and its connection to the MCU.

Switch	Function	MCU
SW1	Connects to an IRQ line for user controls.	P40, IRQ8-DS, Pin 95
SW2	Connects to an IRQ line for user controls.	P41, IRQ9-DS, Pin 93
SW3	Connects to an IRQ line for user controls.	P44, IRQ12-DS, Pin 90
SW4 (RESET)	When pressed, the RDK microcontroller and J-Link circuit are reset.	RES# , Pin 10

Table 6-1: Switch Functions

6.2. Debug LCD Module

A debug LCD module is supplied on the RDK. The debug LCD module uses an SPI interface to reduce the pin allocation. Software contrast control is also provided. The module supplied with the RDK uses 3.3v. The display is a 96 x 64 graphics display and uses a white LED backlight. The backlight is on by default and can be toggled OFF by setting MCU port P21 low. The backlight brightness can be also controlled on a duty cycle using MTU pin MTIOC1B or TPU pin TIOCA3. **Table 6-2** shows the pin allocation and signal names used for the graphics LCD connector.

J11					
Pin	Circuit Net Name	MCU	Pin	Circuit Net Name	MCU
1	+5V Backlight Positive Anode	-	2	BL_ENA	P21, pin 27
3	GND	-	4	GND	-
5	GND	-	6	LCD-CS	PC2, pin 50
7	RSTOUT# (Inverted RESET_IO)	PC3, pin 49 (inv)	8	LCD-RS	P51, pin 43
9	+3.3V	-	10	+3.3V	-
11	SCK	RSPCKA, pin 47	12	MOSI	MOSIA, pin 46
13	MOSI	MOSIA, pin 46	14	MOSI	MOSIA, pin 46
15	+3.3V	-	16	+3.3V	-
17	+3.3V	-	18	+3.3V	-
19	GND	-	20	+3.3V	-

Table 6-2: Debug LCD Module Connections

6.3. LEDs

There are 17 LEDs on the RDK board.

- The green 'POWER' LED (LED3) lights when the board is powered.
- The Segger J-Link OB Debugger Interface LED (LED16) illuminates when the Debugger USB Interface is connected to a host PC.
- There are 12 user LEDs (LED4-LED15) that are connected to IO ports. Each LED will light when their corresponding port pin is set low. The 12 user LEDs are arranged to show the winding phases of a motor control circuit.
- The remaining 2 LED's (LED2 and LED1) are Ethernet specific, and are not accessed directly from the MCU.

Table 6-3 shows the user LED pin references and their corresponding microcontroller port pin connections.

LED Reference (As shown on silkscreen)	Color	Circuit Net Name	MCU
LED1 (Speed ENET)	Green (On for 100BT)	-	N/A
LED2 (1PPS ENET)	Red	-	N/A
LED3 (5V Power)	Green	-	N/A
LED4	Green	LED6	PD5, pin 81
LED5	Green	LED12	PE3, pin 75
LED6	Red	LED3	PD2, pin 84
LED7	Red	LED9	PE0, pin 78
LED8	Green	LED5	PD4, pin 82
LED9	Green	LED11	PE2, pin 76
LED10	Red	LED2	PD1, pin 85
LED11	Red	LED8	PD7, pin 79
LED12	Green	LED4	PD3, pin 83
LED13	Green	LED10	PE1, pin 77
LED14	Red	LED1	PD0, pin 86
LED15	Red	LED7	PD6, pin 80
LED16 (Segger J-Link)	Green	-	N/A
D5 (USB Power)	Green	-	N/A

Table 6-3: LED Port

6.4. 3 – Axis Accelerometer

The RDK includes an Analog Devices ADXL345 3-axis accelerometer. The part is connected to I2C SDA (MCU Pin 33) and SCL (MCU Pin 34).

I2C Address: 0x3A (0011101r) where r = R/W

6.5. Digital Temp Sensor

The RDK has component placement options for two Analog Devices digital temperature sensors (ADT7410TRZ or ADT75ARZ). Both are connected to the I2C SDA (MCU Pin 33) and SCL pins (MCU Pin 34).

I2C Address = 0x90

ADT75 = (1001aaar) where aaa = A2:A1:A0, r=R/Wn

ADT7410 = (10010aar) where aa = A1:A0, r=R/Wn

6.6. Micron Serial Flash

A Micron Phase Change Memory (PCM) serial flash is provided for user non-volatile storage. PCM memory has greater write endurance than standard serial flash. This part, NP5Q128A13ESFC0E, is 128 megabit and is accessed by the SPI Bus using SFL-CS (MCU Port PC0).

6.7. MicroSD Memory Card Slot

A MicroSD memory card slot is provided for file system data storage. This is configured to use SPI mode rather than nibble mode and is accessed using SD-CS (MCU Port PC4).

6.8. Potentiometer

A single turn potentiometer is connected to the ADC channel AN002 of the microcontroller. This may be used to vary the analog voltage input value to this pin between 3V3A and Ground. The potentiometer can also be used as a volume control through software.

Note: The potentiometer is fitted to offer an easy way of supplying a variable analog input to the controller. It does not necessarily reflect the accuracy of the controllers ADC. Please see the device manual for details.

6.9. Serial port

The Serial module allows the MCU to communicate to a Host PC through the RS-232 connector, J5, using RS232Rx and RS232Tx. The serial port is configured in DCE mode allowing direct connection to a PC without a Null modem. The serial module can also be used as a serial debug port. Table 6-4 contains details of the specific pin functions and their locations.

Description	Function	MCU Pin	Connector Pin
TXD2	Serial Transmission Pin	44	J5.2
RXD2	Serial Reception Pin	42	J5.3

Table 6-4: Serial port pin details

6.10. Reset Circuit

The RDK includes a user reset switch (SW4) to reset both the RX63N MCU and Debugger MCU. This is connected to the internal reset circuit on the RX63N (RES#) and input on the J-Link OB Segger Debugger.

There is a peripheral reset control line connected to PC2 (pin 49) on the RX63N which can be used to reset major peripherals at once. This includes the Ethernet PHY, Beagle Port, Application Header, and Debug LCD.

6.11. Audio (Audio Out, Mic, Speaker)

An amplified stereo audio output jack is provided and connected to the timer circuit. Audio can be generated using a buffered output on TPU0 for left (TIOCA0) and right (TIOCB0) channels. The headphone stereo amp is powered by a National Semi LM4808M. An on-board Analog Devices Inc. (ADI) Silicon microphone (ADMP401) is connected to the ADC channel AN005 using an ADI SSM2167 low voltage Microphone preamplifier. Note that the default is to have JP7, SPK EN, fitted. This enables the on-board Star Micronics speaker. Removing this jumper disables the on-board speaker. Remove the jumper to use the headphone audio jack. The on-board speaker is powered by a SSM2377 audio power amplifier to increase volume. Both the microphone and on-board speaker amplifiers can be turned OFF by setting AMP_SHDN (PA2) low. DAC audio on the right channel is also supported using SPL SEL JP17.

Circuit Net Name	Function	MCU Pin	MCU Function
AUD_L	Audio Left	70	TIOCA0
AUD_R	Audio Right	29	TIOCB0
AN005	Microphone Analog In	89	AN005
AN002	Volume Control Analog In	92	AN002
AMP_SHDN	Mic. & On-board Speaker Amp. Shutdown	68	PA2
AN006	Right Audio Analog Feedback	88	AN006
P05/DA1/IRQ13-A	DAC Right Audio Option (Can select this option using JP17)	100	DA1

6.12. RCAN

The RCAN module can be controlled by the MCU through the CTx0 (Port pin P32) and CRx0 (Port pin P33) lines, or controlled externally through the header connections CTx0 and CRx0. The **Table 6-5** contains details of the specific pin functions and their locations. Note that an 8 pin Renesas R2A25416SP CAN transceiver is fitted to the board.

Description	Function	MCU Pin	Header Pin
CTx0	RCAN Transmission Pin	18	CAN High J6.1
CRx0	RCAN Reception Pin	17	CAN Low J6.3

Table 6-5: RCAN port pin details

6.13. USB

The USB module can be configured as Host, Function, or OTG with the correct switch settings on SW6.

- Function / Device / Slave mode: This mode does not take any external power circuitry to implement. Simply put the SW6 DIP switches to the proper setting as in table 6-7 and configure the software appropriately.
- Host mode: Connect the included MiniAB to Host adapter Cable to have the proper cable connection for USB Host. This mode uses U12 and associated passive circuitry to create USB Power. Set SW6 DIP switches to the settings shown in table 6-7. Note that you will have to add an external 5V regulated supply that sources 1 Amp or greater to J4 in order to meet the USB Specification for power delivery (500ma).
- OTG: Set SW6 DIP switches to the settings shown in **Table 6-7**. Note that the Maxim MAX3353EEUE and associated circuitry will create the proper USB OTG voltages. Note the Maxim IC must be configured in software using the I2C bus (Address 0x58) for proper operation. Note that you will have to add an external 5V regulated supply that sources more than 1 Amp to J4 in order to meet the USB Specification for power delivery (500ma).

Table 6-6 contains details of the USB signal descriptions and pin connections.

Description	Function	Microcontroller Pin Number
USB_VBUS	USB cable connection monitor pin	30
USD+	USB data I/O pin	37
USD-	USB data I/O pin	36
VCC_USB	Power supply pin for USB built-in transceiver	35
VSS_USB	Ground pin for USB built-in transceiver	38
USB_DPUPEA	Pull-up control pin A	25
USB_ID	OTG USB ID	28
USB_OVRCURA_DPUPEB	Host / OTG Over-current detect / Function Pull-up control pin B	32
USB_DRPD	D- Pull Down	26
USB_DPRPD	D+ Pull Down	23
USB0_EXICEN	Expansion	27

Table 6-6: USB Pin Definitions

Table 6-7 details how to set the SW6 DKP switches for each USB mode.

USB DIP Switch Settings (SW6)				
Mode No.	SW6.1	SW6.2	SW6.3	SW6.4
USB Host	OFF	OFF	ON	OFF
USB Function / device / slave	ON	OFF	OFF	ON
USB On the Go (OTG)	OFF	ON	OFF	OFF

Table 6-7: USB DIP Switch SW6 settings

6.14. Ethernet

The Ethernet module conforms to the Ethernet or IEEE802.3 media access control (MAC) standard. The Ethernet controller is connected to the direct memory access controller for Ethernet controller (E-DMAC) and carries out high-speed data transfer to and from the memory. In addition, the Ethernet controller is connected to the National Semiconductor 10/100 Mbps DP83640 physical transceiver chip enabling it to perform transmission and reception of Ethernet frames. Note that the chip is configured in Reduced Pin-count mode (RMII). The Ethernet PHY is configured at power-on reset for Auto-Negotiation, advertising 10Base-T and 100Base-TX in both full and half-duplex modes.

Each RDK is pre-programmed in factory with a unique IEEE assigned MAC address ranging from 00:30:55:08:00:01 to 00:30:55:08:FF:FF. The MAC address programmed into the part at the factory is shown on the front of the board and is stored in data flash at memory address 0x107FF0. If there is a problem with the pre-programmed MAC address, the demonstration code will default to a default MAC address.

Table 6-8 contains details of the signal descriptions and pin connections. All connections to the MCU are direct.

Net Name	Function	MCU Pin Number
ETH_CLK	Transmit/Receive Clock	58
TX_EN	Transmit Enable	56
RMII_TXD0	Transmit Data, Bit 1	55
RMII_TXD1	Transmit Data, Bit 2	54
RMII_MAS	Master Mode (high)	NC
RX_ER	Receive Error	57
RMII_RXD0	Receive Data, Bit 1	59
RMII_RXD1	Receive Data, Bit 2	61
CRS	Carrier Sense	53
MDC	Management Data Clock	66
MDIO	Management data I/O	67
ETH-IRQ	Power Down / Interrupt	98

Table 6-8: Ethernet Module Connections

6.15. Option Links and Jumper Settings

Table 6-9 and Table 6-10 detail the function of the various option links contained on the RX63N RDK. There is also a 3-pin on-board speaker function select jumper (JP17). By default, this jumper is set to play audio from the right audio channel (MCU pin 29) out the on-board speaker. It can be cut and modified to use MCU pin 100 (P05/DA1) instead.

Table 6-9 details the Ethernet LED Configuration Resistor.

Ethernet Configuration Options				
Reference	Function	Fitted	Alternative (Removed)	Related To
R12	Ethernet Configuration	LED Configuration – Link/Activity (J1.L), Speed (LED14), Collision (J1.R)	LED Configuration – Link (J1.L), Speed (LED14), Activity (J1.R)	-

Table 6-9: Ethernet Configuration Options

Jumper Settings

Reference	Function	Open	Short	Notes
JP7	Speaker Enable	On Board Speaker Disabled	On Board Speaker Enabled	
JP9	CAN terminator disable	Removes the CAN termination resistor – useful in some debugging situations	CAN terminator active	Cut the trace between the pads to 'open' the circuit
JP10	Switch 3 Isolation	Removes Switch 3 from P42/AN2 Circuit	Switch 3 acts on P42/AN2	Cut the trace between the pads to 'open the circuit
JP11	Switch 3 Isolation	Removes Switch 2 from P41/AN1 Circuit	Switch 2 acts on P41/AN1	Cut the trace between the pads to 'open the circuit
JP12	Switch 3 Isolation	Removes Switch 1 from P40/AN0 Circuit	Switch 1 acts on P40/AN0	Cut the trace between the pads to 'open the circuit
JP13	J-Link Disable	J-Link OB debugger is active and works normally	J-Link OB is disabled with all output high impedance. This is useful for running a program without the debugger or using the boot mode of the RX63N	-
JP16	CAN Level Shifter Enable	Disconnects CAN level shifter from P33/CRx0_RXD6	CAN Level Shifter active	Cut the trace between the pads to 'open' the circuit

Table 6-10 below describes the function of the jumper headers. The default configuration is indicated by **BOLD** text.

Jumper Settings				
Reference	Function	Open	Short	Notes
JP7	Speaker Enable	On Board Speaker Disabled	On Board Speaker Enabled	
JP9	CAN terminator disable	Removes the CAN termination resistor – useful in some debugging situations	CAN terminator active	Cut the trace between the pads to 'open' the circuit
JP10	Switch 3 Isolation	Removes Switch 3 from P42/AN2 Circuit	Switch 3 acts on P42/AN2	Cut the trace between the pads to 'open the circuit
JP11	Switch 3 Isolation	Removes Switch 2 from P41/AN1 Circuit	Switch 2 acts on P41/AN1	Cut the trace between the pads to 'open the circuit
JP12	Switch 3 Isolation	Removes Switch 1 from P40/AN0 Circuit	Switch 1 acts on P40/AN0	Cut the trace between the pads to 'open the circuit

Jumper Settings				
Reference	Function	Open	Short	Notes
JP13	J-Link Disable	J-Link OB debugger is active and works normally	J-Link OB is disabled with all output high impedance. This is useful for running a program without the debugger or using the boot mode of the RX63N	-
JP16	CAN Level Shifter Enable	Disconnects CAN level shifter from P33/CRx0_RXD6	CAN Level Shifter active	Cut the trace between the pads to 'open' the circuit

Table 6-10: Jumper header settings

6.16. Oscillator Sources

All crystals are provided by NDK, Nihon Dempa Kogyo Co., LTD. A crystal is fitted on the RDK and used to supply the main clock to the Renesas microcontroller. **Table 6-11** details the crystals that are fitted on the RX63N RDK.

Component	Part Number	Function	Frequency
Crystal (X1)	NX3225GA-12M	CPU/USB Clock	12 MHz
Crystal (X2)	NX3215SA-32K	CPU/RTC Clock	32.768 KHz
Crystal (X3)	NX3225GA-25M	Ethernet Clock	25 MHz
Crystal (X4)	NX3225GA-12M	J-Link OB System	12 MHz

Table 6-11: Oscillators / Resonators

6.17. Total Phase Beagle Debug Header

The Beagle I2C/SPI Protocol Analyzer is a non-intrusive USB-based bus monitor that can capture, display, and filter I2C and SPI data as it appears on the bus. Using both the Data Center Software and Beagle analyzer, users can easily view I2C bus traffic (up to 4 MHz) and SPI bus traffic (up to 24 MHz) in real time. Additional functionality allows engineers to filter data against a wide variety of parameters, or instantly search for specific hexadecimal or ASCII data patterns during a live capture. The Beagle analyzer is fully supported on Windows, Linux, and Mac OS X, and comes with free software, free APIs, free technical support, and free software/firmware upgrades.

Total Phase manufactures powerful and affordable USB, I2C, SPI, and CAN tools for embedded systems engineers. The complete line of Total Phase host adapters and protocol analyzers are the development and debugging tools of choice for Fortune 500 companies, small businesses, and research institutions all over the world.

For more technical information, online demos, and ordering information, visit www.totalphase.com.

Chapter 7. RX63N Operating Modes

This RDK supports the 4 CPU modes: Debug Mode, Run Mode, USB Boot Mode and SCI Boot Mode. These modes are selected by SW5 and alter the state of MCU ports MD, PC7, and EMLE. The base configurations should only be set when the RDK is powered OFF.

- Debugging mode is required for all debugging purposes. When the RDK is placed in Debug mode, a program will run unless a debugging connection is made.
- Run mode will disable MCU on-chip emulator communication and disable debugging.
- USB and SCI boot modes allow debugging of the MCU through the user USB port (J9) and serial port (J5).

Table 7-1 details how to configure SW5 for each of these modes.

	SW5.1	SW5.2	SW5.4
Debug Mode	OFF	OFF	ON
Run Mode	OFF	OFF	OFF
USB Boot Mode	ON	OFF	OFF
SCI Boot Mode	ON	ON	OFF

Table 7-1: MCU Operating Modes Table

Chapter 8. Programming Methods

The RDK is intended for use with HEW, IAR, and KPIT Eclipse IDE software development tools. The board includes an on-board RX621 based Segger J-Link OB debugger. Refer to RX63N Group Hardware Manual for details of programming the microcontroller without using these tools. The on-board J-Link OB is pre-programmed at the factory and configured for normal operation. The on-board debugger can be disabled by fitting a jumper to the J-Link disable 2-pin header (JP13). This is useful if the board needs to be put into either USB or SCI boot mode. The RX621 based Segger J-Link OB is located under the Okaya LCD. The Jlink interface is pre-programmed at the factory final test and can self-update later on if new versions are available.

Chapter 9. Headers

9.1. Extension Header 1

Table 9-1 shows the controller pin headers for JN1 and their corresponding microcontroller connections. The header pins connect directly to the microcontroller pin.

JN1 Extension Header					
Pin	Circuit Net Name	MCU Pin	Pin	Circuit Net Name	MCU Pin
1	5V0	-	2	Ground	-
3	3V3	-	4	Ground	-
5	3V3A	97	6	AGND	3, 94, 99
7	AVREF3V3	96	8	RESET#	10
9	SWITCH1 (P40/IRQ8-DS/AN000)	95	10	SWITCH2 (P41/IRQ9-DS/AN001)	93
11	SWITCH3 (P44/IRQ12-DS/AN004)	90	12	AN003 (P43/IRQ11-DS/AN003)	91
13	AN006 (P46/IRQ14-DS/AN006)	88	14	VREFH0_3V3	50
15	AGND	3, 94, 99	16	PMOD1_CS (PE4)	74
17	PMOD_SCK (PE5/RSPCKB)	73	18	PMOD_MOSI (PE6/MOSIB)	72
19	PMOD_MISO (PE7/MISOB)	71	20	MOSI (PC6/MOSI)	46
21	MISO (PC7/MISO)	45	22	SCK (PC5/SCK)	47
23	SFL-CS (PC0/SSLA1)	52	24	SD-CS (PC4/SSLA0)	48
25	SDA (P13/SDA)	33	26	SCL (P12/SCL)	34

Table 9-1: JN1 Extension Header

9.2. Extension Header 2

Table 9-2 shows the controller pin headers for JN2 and their corresponding microcontroller connections. The header pins connect directly to the microcontroller pin.

JN2 Extension Header					
Pin	Circuit Net Name	MCU Pin	Pin	Circuit Net Name	MCU Pin
1	RSTOUT#	-	2	P53/BCLK	41
3	P35/NMI	15	4	Ground	-
5	PWMLP-OUT (Audio Generator)	40	6	PA6	64
7	PA7	63	8	P21 (BL_ENA)	27
9	PC1	51	10	NC	-
11	NC	-	12	NC	-
13	LED1 (PD0/IRQ0/AN008)	86	14	LED2 (PD0/IRQ0/AN008)	85
15	LED3 (PD2/IRQ2/AN010)	84	16	LED4 (PD3/IRQ3/AN011)	83
17	LED5 (PD4/IRQ4/AN012)	82	18	LED6 (PD5/IRQ5/AN013)	81
19	LED7 (PD6/IRQ6/AN6)	80	20	LED8 (PD7/IRQ7/AN7)	79
21	LED9 (PE0/ANEX0)	78	22	LED10 (PE1/ANEX1)	77
23	LED11 (PE2/AN0)	76	24	LED12 (PE3/AN1)	75
25	P24 (PMOD2_CS)	24	26	NC	-

Table 9-2: JN2 Extension Header

9.3. Application Header

Table 9-3 shows the controller pin headers for J8 and their corresponding microcontroller connections. The header pins connect directly to the microcontroller pin.

J8 Application Header					
Pin	Circuit Net Name	MCU Pin	Pin	Circuit Net Name	MCU Pin
1	NC	-	2	GND	-
3	3V3	-	4	GND	-
5	NC	-	6	NC	-
7	NC	-	8	NC	-
9	NC	-	10	NC	-
11	NC	-	12	NC	-
13	NC	-	14	NC	-
15	SPI_CS (PJ3/WIFI-CS)	4	16	RSTOUT#	10
17	PWR_OFF (PE4)	74	18	NC	-
19	SPI_DIN (MOSI)	46	20	SPI_CLK (SCK)	47
21	UART_IN (CTx0_TXD6)	18*	22	SPI_DOUT (MISO)	45
23	SPI_INTR (WIFI-IRO)	100	24	UART_OUT (CRx0_RXD6)	17
25	GPIO (PE5)	73*	26	GPIO (PE6)	72*

Table 9-3: J8 Application Header

9.4. PMOD™ Interfaces

Two Digilent PMOD™ (Interface Type 2A, expanded SPI) connection headers are available on the RDK. These interfaces can be access on the SPI bus using MCU port PE4 and P24 as chip selects. **Table 9-4** shows the PMOD™ headers and their corresponding microcontroller connections.

Pin	Signal	Direction	PMOD1 (J15)		PMOD2 (J16)	
			Circuit Name	Function	Circuit Name	Function
1	Select	Out	PE4	PMOD1_CS	P24	PMOD2_CS
2	SDI	Out	PE6	PMOD_MOSI (MOSIB)	PE6	PMOD_MOSI (MOSIB)
3	SDO	In	PE7	PMOD_MISO (MISOB)	PE7	PMOD_MISO (MISOB)
4	SCK	Out	PE5	PMOD_SCK (RSPCKB)	PE5	PMOD_SCK (RSPCKB)
5	GND	-	GND	-	GND	-
6	VCC	-	3V3	-	3V3	-
7	IRQ	In	P55	PMOD_PIN7 (IRQ10)	P55	PMOD_PIN7 (IRQ10)
8	RST/IRQ	Out	PA1	PMOD_PIN8 (IRQ11)	PA1	PMOD_PIN8 (IRQ11)
9	GPIO	-	LED11	PMOD_PIN9 (PE2)	LED11	PMOD_PIN9 (PE2)
10	GPIO	-	LED10	PMOD_PIN10 (PE1)	LED10	PMOD_PIN10 (PE1)
11	GND	-	GND	-	GND	-
12	VCC	-	3V3	-	3V3	-

Table 9-4: PMOD Headers

Chapter 10. Code Development

10.1. Overview

Note: For all code debugging using Renesas software tools, the CPU board must be connected to a PC USB port via the on-board Segger J-Link OB debugger.

Due to the continuous process of improvements undertaken by Renesas the user is recommended to review the information provided on the Renesas website at www.renesas.com/rdkRX63N to check for the latest updates to the Compiler and Debugger manuals.

10.2. Compiler Restrictions

We provided both the GNU and Renesas Toolchains with this kit. Note that HEW didn't full support the GNU compiler at the time of the kit launch. The GNU Toolchain has NO restrictions. The RX compiler was used with ALL the Micrium uC/OS-III and Exosite example projects.

The Renesas Toolchain is fully functional for a period of 60 days from first use. After the first 60 days of use have expired, the compiler will default to a maximum of 128k (code and data). To use the Renesas Toolchain with programs greater than this size you will need to purchase the full version tools from your Renesas distributor

Warning: The protection software for the compiler will detect changes to the system clock. Changing the system clock back in time may cause the trial period to expire prematurely.

10.3. Breakpoint Support

Breakpoint support is directly supported by Segger J-Link OB emulator.

10.4. Memory Map

H'0000 0000	On-Chip RAM
H'0001 8000	Reserved Area
H'0008 0000	Peripheral I/O Registers
H'0010 0000	On-chip ROM (data flash)
H'0010 8000	Reserved Area
H'007F 8000	FCU-RAM
H'007F A000	Reserved Area
H'007F C000	Peripheral I/O Registers
H'007F C500	Reserved Area
H'007F FC00	Peripheral I/O Registers
H'0080 0000	Reserved Area
H'00F8 0000	OnChip ROM (program ROM) (Write Only)
H'0100 0000	On-Chip Flash
H'FEFF E000	OnChip ROM (FCU firmware) (Read Only)
H'FF00 0000	Reserved
H'FFF8 0000	OnChip ROM (program ROM) (Read Only)
H'FFFF FFFF	

Table 10-1: Memory Map

Chapter 11. Component Placement

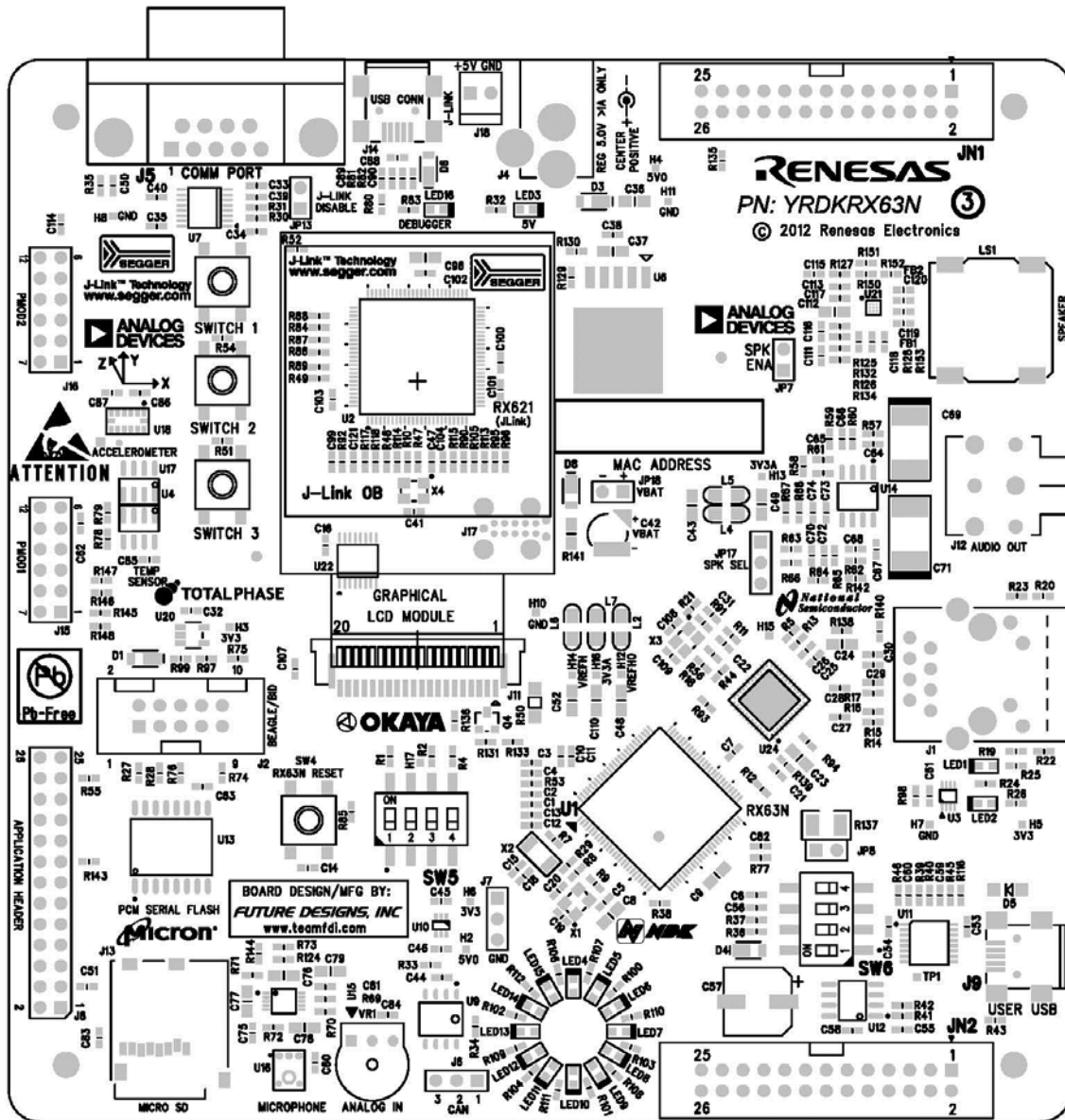

Table 111-1: Component Placement

Chapter 12. Additional Information

12.1. Hardware Partner Information

Hardware partners played an integral role in the definition, development, and deployment of this RDK. Without their numerous contributions, this project would not have been possible. Contributors include National Semiconductor for the DP83620 Precision PHYTER - IEEE1588 Precision Time Protocol Ethernet transceiver and LP38500 3.3v regulator. Analog Devices supplied the ADXL345 3-Axis Accelerometer, SSM2167 microphone preamplifier and ADMP401 digital microphone, ADT7410TRZ (or ADT75ARZ) temp sensor, SSM2377 Audio Amplifier, and ADM3101E RS-232 line driver / receiver. NDK contributed all 4 crystals for the board. Micron contributed their Phase Change Serial Flash Memory (NP5Q128A13ESFC0E). Okaya provided the 96 x 64 backlit graphics LCD. Segger provided all the Debugger circuitry for their J-Link OB. Star Micronics provided their NDT-03C speaker. TotalPhase provided the connectors to interface to their beagle serial channel debugger. And finally, Future Designs, Inc. provided the hardware customization, schematic capture, PCB design and layout, manufacturing, and Supply Chain Management services for this RDK. For more information or to contact our partners please refer to their websites:

- Analog Devices – <http://www.analog.com>
- NDK <http://www.ndk.com>
- Future Designs – <http://www.teamfdi.com>
- Micron – <http://www.micron.com>
- National Semiconductor – <http://www.national.com>
- Okaya – <http://www.okaya.com>
- Segger – <http://www.segger.com>
- Seiko Instruments – <http://www.seikoinstruments.com/>
- Totalphase – <http://www.totalphase.com>

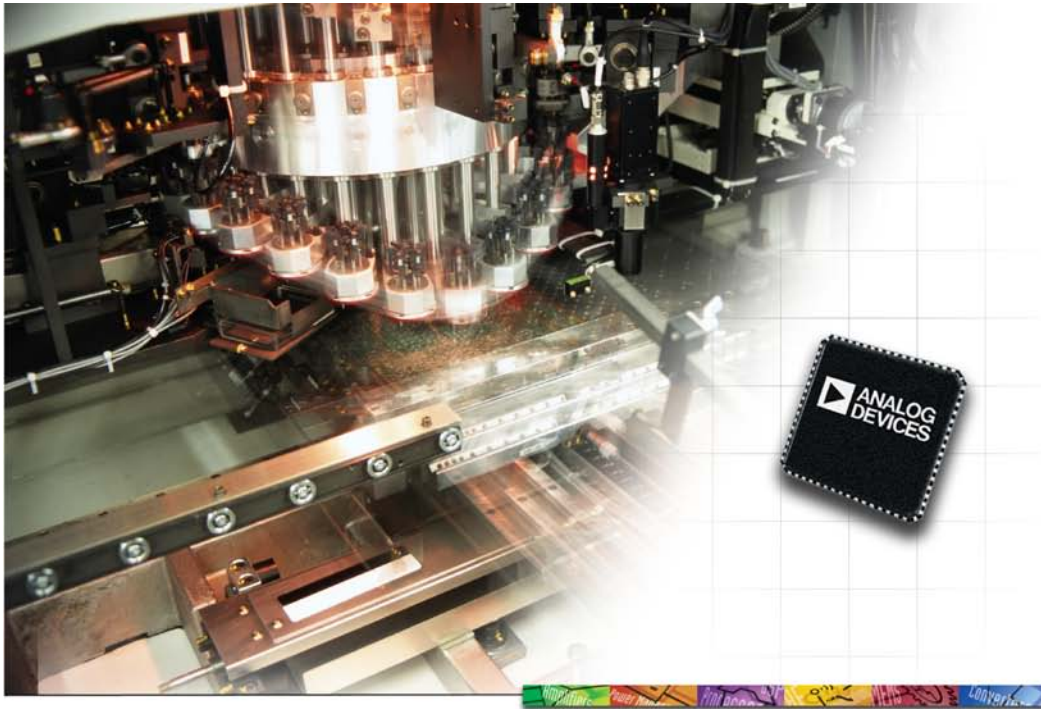

Analog Devices - The Leader in High Performance Signal Processing Solutions

Analog Devices sets the standard for innovation and excellence in signal processing. Our comprehensive portfolio of linear, mixed signal, MEMS and digital processing technologies are backed by leading design tools, applications support, and systems-level expertise. These solutions play a fundamental role in converting, conditioning, and processing real-world inputs such as light, sound, temperature, motion, and pressure into electrical signals to be used in a wide array of electronic equipment.

ADI is synonymous with high performance among electronics manufacturers. ADI collaborates with each of our customers to define the very best in the quality of the user experience. That means the clearest image, crispest sound, and optimum interface, size and performance in thousands of consumer, medical, communications, industrial and other applications.

MAKEADIFFERENCE

www.analog.com



Analog Devices Products Featured in the Renesas Demonstration Kit

ADXL345 Low Power, 3-Axis Digital *i*MEMS Accelerometer

- ± 2 g, ± 4 g, ± 8 g, and ± 16 g ranges
- Ultralow power
 - From 30 μ A to 140 μ A in full measurement mode
 - 0.1 μ A in standby mode at $V_S = 2.5$ V (typ)
- Supply Voltage: 2.0 V to 3.6 V
- 10-bit to 13-bit / 4mg resolution
- SPI and I²C digital interfaces
- Temp range: -40°C to $+85^{\circ}\text{C}$
- 3 mm \times 5 mm \times 1 mm LGA package



ADMP401 Analog Output, Omni-Directional *i*MEMS Microphone

- SNR: 62 dBA
- Flat Frequency Response: 100 Hz to 15 kHz
- PSRR: 70 dBV
- Sensitivity: -42 dBV
- Current Consumption: < 250 μ A
- 4.72 mm \times 3.76 mm \times 1.00 mm SMT package

SSM2167 Low Power Microphone Preamp

- Low shutdown current < 2 μ A
- Adjustable compression ratio and noise gate threshold
- Low noise and distortion: 0.2% THD + N
- 20 kHz bandwidth
- Single 3 V operation

ADT7420 High Accuracy, 16-Bit Digital Temp Sensor

- $\pm 0.25^{\circ}\text{C}$ temp accuracy from -20°C to $+105^{\circ}\text{C}$
- I²C-compatible interface
- Supply voltages: 2.7 V to 5.5 V
- Operating temperature: -40°C to $+150^{\circ}\text{C}$
- LFCSP package

ADM3101 ± 15 kV ESD Protected, Single-Channel RS-232 Line Driver/Receiver

- Conforms to EIA/TIA-232E and CCITT V.28 Specifications
- Data Rate: 460 kbps
- 0.1 μ F charge pump capacitors
- Contact discharge: ± 8 kV ap discharge: ± 15 kV

www.analog.com



SII Electronic Components for Any Requirement !

Super-small,
low current consumption

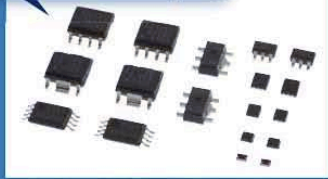

CMOS IC

ICs for various power supplies
Memory ICs (EPROMs)
Sensors (temperature, magnetism, etc.)
Mini-analog
Real-time clocks

Best suited for
microprocessors



Quartz Crystal

Compact SMD tuning-fork quartz crystal unit
Quartz crystal unit for clocks
Quartz crystal unit for radio-controlled clocks

Maximum power
in a small body!



Micro Battery

Coin-type lithium rechargeable batteries
Capacitors(Coin-type, Chip-type)
Mercury-free silver oxide batteries

Compact
Energy saving
High accuracy

Module design and
assembly technology

Low-voltage operation

High reliability

Vivid and realistic



LCD Device

Color TFT liquid crystal modules
Color/monochrome STN liquid crystal modules
STN liquid crystal panels
Backlight modules
Optical films for backlights

Small, precision
machining and
reflowable



DIANET Rare Earth Magnet

Samarium-cobalt (SmCo) magnets
Miniature precision springs
Metal diaphragms
etc.

Made by SII's unique
precision machining technology



SPRON Superior performance Co-Ni Alloy Product

Most advanced
mounting technology



From module mounting commission to OEM production

Cleanroom-based (Class 10000) unified production
SMT/BGA/COB mounting
Mountable onto PSBs and FPCs
Module/completed product assemblies

Ideal for various applications !

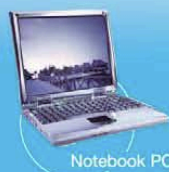

Quartz Crystal Units



■ Model Names of Surface-mount (SMD) Products

Our system for surface-mount (SMD) product model names is as follows:

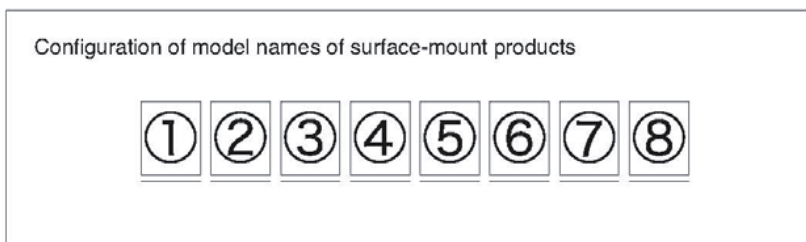

① Symbol for NDK: N

② Symbols for products: See Table 1.

Table 1 Symbols for products

Product symbol	Product
X	Crystal oscillator
T	Temperature-compensated crystal oscillator (TCXO)
H	Oven-controlled crystal oscillator (OCXO)
V	Voltage-controlled crystal oscillator (VCXO)
P	Simple packaged crystal oscillator (SPXO)
Z	Crystal clock oscillator
M	Monolithic filter
S	SAW device

③④ The nominal length (mm) of a product main body in the longitudinal direction is expressed in two digits. The third digit is rounded off.

⑤⑥ The nominal length (mm) of a product main body in the lateral direction is expressed in two digits. The third digit is rounded off.

Examples: 6.0 mm x 3.5 mm is expressed as 6035.

11.8 mm x 5.5 mm is expressed as 1255.

⑦ Symbols for constituent materials and sealing methods: See Table 2.

Table 2 Symbols for sealing methods

Product sealing category	Symbol	Product sealing method	Package material	
			Base	Cover
Hermetic sealing	C	Adhesive sealing	Ceramics	
	M	Resin molding	Resin	
	P	Adhesive sealing	Resin	
	G	Glass sealing	Ceramics	
	R	Resistance weld sealing	Ceramics	Metal
	S, D	Seam weld sealing	Ceramics	Metal
	A	Au/Sn sealing	Ceramics	Metal
Non-hermetic sealing	W	—	Board	Metal
	X	—	Board	Non-metal
	Y	—	Mold	Metal
	Z	—	Mold	Non-metal
Others	B	A printed board on which multiple crystal elements were mounted with a nameplate attached to its top surface		

⑧ Detailed symbols for the order of model name registration: A to Z

When products designed as lead-mount ones have been converted during secondary processing into surface-mount ones, the product model names given before secondary processing are conventionally used to describe them.

Example: AT-41CD2 (AT-41 with a pedestal)



Future Designs, Inc.

A True Technology and Solutions Provider

Future Designs, Inc., provided the hardware customization, schematic capture and PCB design and layout for the YRDKRx62N platform for Renesas. In addition, FDI provided full turn-key manufacturing, automated functional test and packaging for the production kits.

FDI offers a full range of turn-key product design and production support

- Schematic capture
- Printed Circuit Board layout & design
- New product conceptual design & prototypes
- PTH to SMT conversions
- Design/redesign for manufacturing (DFM)
- Design for test (DFT)
- High-volume/cost-effective designs
- Production for low-volume, high-mix or high-volume cost-sensitive designs
- One-stop shopping for all of your engineering and production needs
- Successful 21 year history of design and production for partner customers

FDI Strategic Alliances



- **Renesas Alliance Partner**
Microcontrollers and Embedded Design



- **Arrow ACES Partner**
Proud Member Arrow Consulting Engineering Services



- **Avnet Partner**
Franchise Distribution Agreement for Embedded Products

FDI has been a supplier of development kits and tools to the embedded engineering community for almost 15 years. We offer a variety of tools for μ C development, Flash ISP programmer, MDIO Clause 22 and Clause 45, I²C.

www.teamfdi.com

256-883-1240

Omneo™ P5Q

Phase Change Memory

128Mb, 90nm, Serial Interface

Phase change memory (PCM) is today's technology breakthrough. Like Flash memory, PCM is a nonvolatile memory that can store bits even without a power supply. But unlike Flash, data can be read at rates comparable to DRAM and SRAM. PCM blends together the best attributes of NOR Flash, NAND Flash, EEPROM, and RAM.

The Omneo™ P5Q product family is serial PCM with multiple I/O capability and compatibility with familiar SPI NOR interfaces. Omneo PCM products are built to meet the memory requirements of embedded systems.

Omneo P5Q improves overall system performance and enables software simplification using byte-alterability (or over-write capability) because no erase is required. It also increases system level reliability by delivering 1 million WRITE cycle endurance (compared to 100,000 for NOR Flash).

Omneo P5Q Features

- Byte-alterability (over-write capability)
- 1 million WRITE cycle endurance
- I/O bus width:
 - Quad – 50 MHz (MAX)
 - Single/Dual – 66 MHz (MAX)
- Single supply voltage: 2.7– 3.6V
- Programming time: 0.7 MB/s
- Temperature range: 0°C to +70°C

Applications

- EEPROM and SPI NOR consolidation
- Battery-backed SRAM replacement
- Software simplification
- High endurance



Learn how this new technology can improve the system performance of your next design. Order design samples today or visit the online toolkit at micron.com/pcm.



©2010 Micron Technology, Inc. All rights reserved. Micron, the Micron logo, and Omneo are trademarks of Micron Technology, Inc. Products and specifications are subject to change without notice.

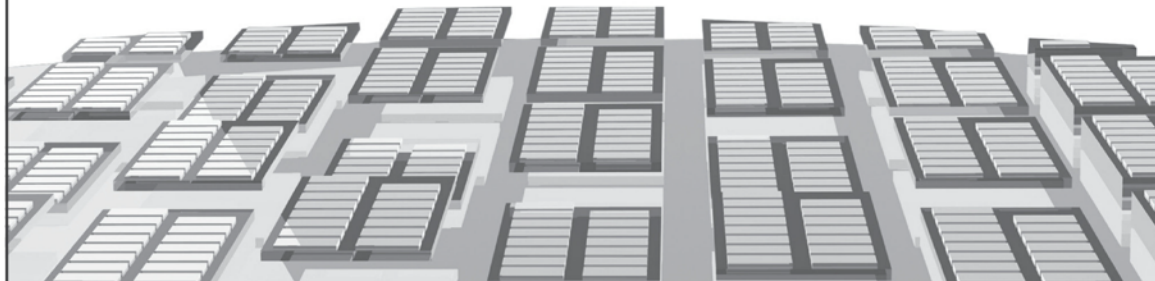

National Semiconductor 10/100 PHYTER®

DP83640

The IEEE 1588 Precision Time Protocol (PTP) is an important improvement to Ethernet systems that provides precise time synchronization for applications such as test and measurement, factory automation, and telecommunications. National Semiconductor's DP83640 Precision PHYTER transceiver is the industry's first to add the IEEE 1588 PTP functionality to a fully-featured, 10/100 Mbps Ethernet PHY.

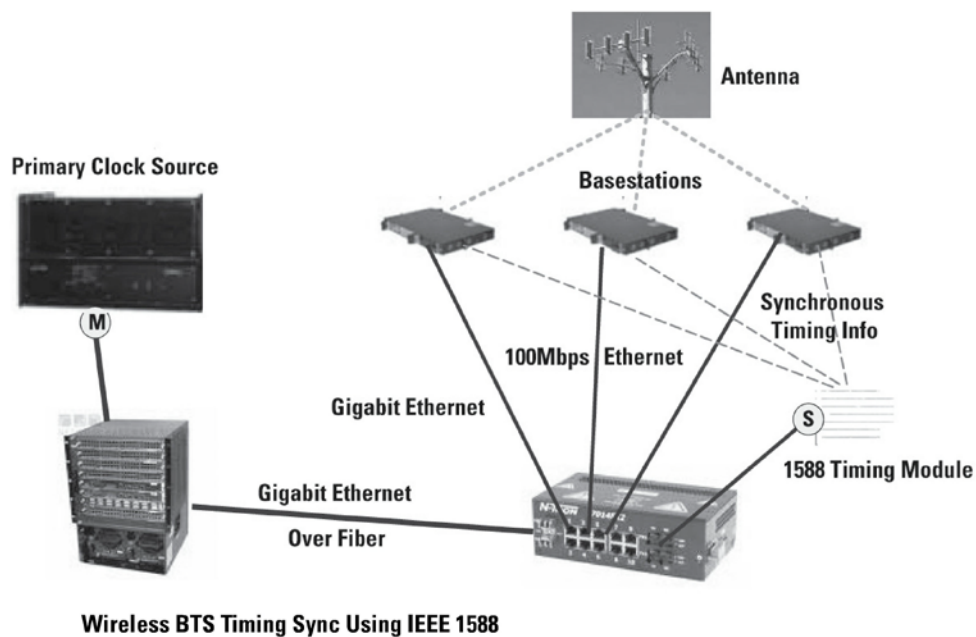

High-Speed Industrial Ethernet

Product ID	Temp Range (°C)	Number of Ports	Interface	Typ Power (mW)	Package
DP83640*	-40 to 85	10/100 Single	MII/RMII	280	LQFP-48
DP83848I	-40 to 85	10/100 Single	MII/RMII/SNI	265	LQFP-48
DP83848VYB	-40 to 105	10/100 Single	MII/RMII/SNI	265	LQFP-48
DP83848J	-40 to 85	10/100 Single	MII/RMII	265	LLP-40
DP83849I	-40 to 85	10/100 Dual	MII/RMII	300/Port	TQFP-80

*IEEE 1588

national.com/ethernet

 **National
Semiconductor**

© National Semiconductor Corporation, August 2010. National, PHYTER, and 10/100 are registered trademarks of National Semiconductor. All other product names are trademarks or registered trademarks of their respective holders. All rights reserved.



Color TFT LCDs

- Size (Diagonal) : 3.5" - 7"
- Resolution: QVGA - WVGA
- Backlight: LED
- Interface: 18 bit TTL RGB
- Touch Panel: Resistive, capacitive, projected capacitive
- Daylight readable options



Chip On Glass (COG)

- Custom and Standard
- No PCB, light weight, low cost
- Minimum external components
- Text, graphic and segment type
- High resolution/duty displays
- RGB or white LED backlight



Custom LCDs

- Full or semi custom
- Color, graphic, COG, panels
- Ruggedized displays
- System on display
- Tailor made form factor



Graphic LCDs

- Wide range of size & resolutions
- TAB, COG, COB ICs
- Yellow green, blue, white, LED backlights
- Extended and wide operating temp range
- Semi and full custom options
- Touch panels available
- TN, STN, FSTN, ASTN technology

Alphanumeric/Text LCDs

- 8 character x 1 line to 40 character x 4 lines
- COG, COB ICs
- Yellow green, blue, white LED backlights
- TAB, COG, COB ICs
- Extended and wide operating temp range
- Semi and full custom options
- TN, STN, FSTN, ASTN technology

800 852 0122

www.okaya.com

lcdsales@okaya.com



On-Line Storefront
www.segger-us.com

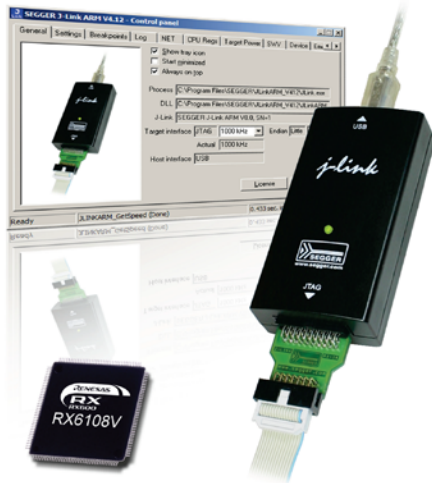

SEGGER J-Link Debug Probe line now supports the Renesas RX.

- EXTREMELY FAST
(2-6 times faster than E1)
- FLASH BREAKPOINTS
- SDK AVAILABLE
- J-FLASH AVAILABLE
(Flash programming utility)

Support for the Renesas RX does not stop at our extremely fast and sophisticated J-Link debug probe line; it carries through to our production flash programming utility and other products. We are here to assist from development to production.

SEGGER Flash Programmer for Renesas RX

Our flash programming utility (Flasher RX) is a superset of our J-Link described above. It contains all of the debug probe features, while being designed for use in a production environment. The Flasher RX has onboard memory to store your binary image permitting simple standalone flash programming.



(Email) info@segger.com

(U.S.) 978.874.0299

(International) +49.2103.2878.0



Total Phase is an industry-leading provider of USB, I2C, and SPI embedded systems development tools for engineers all over the world. Total Phase's mission is to create powerful, high-quality, and affordable solutions for the embedded engineer.



**Aardvark I2C/SPI
Host Adapter**



**Beagle I2C/SPI
Protocol Analyzer**



**Cheetah SPI
Host Adapter**



**Beagle USB 5000
Protocol Analyzer**



**Beagle USB 480
Protocol Analyzer**



**Beagle USB 12
Protocol Analyzer**

*Industry-leading
embedded systems tools*

www.totalphase.com

RenesasUniversity

- ▶ For educators and students. Teach with professional grade tools. Learn MCUs with a modern architecture.

RenesasUniversity.com

Alliance Partners

- ▶ The Alliance Partner Program allows you to connect instantly with hundreds of qualified design consulting and contracting professionals.

America.Renesas.com/Alliance

Renesas Interactive

- ▶ Gain the technical knowledge you need. Evaluate research, and learn at your own pace, where you want, when you want, for free.

RenesasInteractive.com



**A smorgasbord
of support served
with every chip.**

America.Renesas.com/Ecosystem

RenesasRulz.com

Think it. Build it. Post it.

MyRenesas

- ▶ Customize your data retrieval needs on the Renesas website. You'll receive updates on the products that you're interested in.

America.Renesas.com/MyRenesas

RenesasRulz

- ▶ A forum and community site to share technical information, questions and opinions with others who use Renesas MCUs and MPUs.

RenesasRulz.com

Renesas Samples

- ▶ Get a first-hand look at our products. Let us know your needs, and we'll get some samples out to you. It's that simple.

America.Renesas.com/Samples

RENESAS

Renesas Contact Information

For details on how to use High-performance Embedded Workshop (HEW), refer to the HEW manual available on the web site.

For information about the RX63N series microcontrollers refer to the RX600 Group hardware manual.

For information about the RX63N assembly language, refer to the RX Series Software Manual.

Online technical support and information is available at: http://www.renesas.com/renesas_starter_kits

Technical Contact Details

America: techsupport.rta@renesas.com

Europe: tools.support.eu@renesas.com

Japan: csc@renesas.com

General information on Renesas Microcontrollers can be found on the Renesas website at: <http://www.renesas.com/>

Renesas Demonstration Kit (RDK) for RX63N

User's Manual

Publication Date Rev.1.00 24 February 2012

Published by: **Renesas Electronics America, Inc.**

2880 Scott Boulevard

Santa Clara, CA 95050-2554, U.S.A

©2010 Renesas Electronics America, All Rights Reserved.

RX63N Group



Renesas Electronics Corporation

Renesas Electronics America, Inc.

2880 Scott Boulevard

Santa Clara, CA 95050-2554, U.S.A