

General Features



Properties of the TOCON_ABC1

- Broadband pre-amplified SiC UV detector in TO5 housing with concentrator lens cap
- 7 nW/cm² peak radiation results a voltage of approx. 2 V
- RoHS compliant
- Applications: very low UV radiation detection, flame detection

The TOCON pre-amplified UV photodetectors

The TOCON devices are using modern hybride technology to cancel unwanted signal disturbances caused by moisture or electromagnetic radiation. The stable 0...5V output voltage can be directly connected to a SPC controller or a voltage multimeter. No external amplifier is needed.

Specifications

Parameter	Symbol	Value	Unit
Maximum Ratings			
Operating Temperature Range	T_{opt}	-25 ... +85	°C
Storage Temperature Range	T_{stor}	-40 ... +100	°C
Soldering Temperature (5s)	T_{sold}	300	°C
General Characteristics (T=25°C, V_{supply}=+5 V)			
Supply voltage	V_{supply}	2,5 ... 5,0	V
Saturation voltage	V_{sat}	V_{supply}	V
Dark offset voltage	V_{offset}	50	µV
Temperature coefficient	T_C	<+0,3	%/K
Current consumption	I	0,8	mA
Bandwidth (-3 dB)	θ	15	Hz
Risetime (63%) (other risetimes on demand)	t_{rise}	10	ms
Spectral Characteristics (T=25°C, V_{supply}=+5 V)			
Sensitivity at peak	S_{max}	280	mV/nW/cm ²
Wavelength of max. spectral sens.	λ_{max}	280	nm
Sensitivity range (S=0,1*S _{max})	-	210 ... 380	nm
Visible blindness (S _{max} / S _{>405nm})	VB	>10 ¹⁰	-

Spectral Response

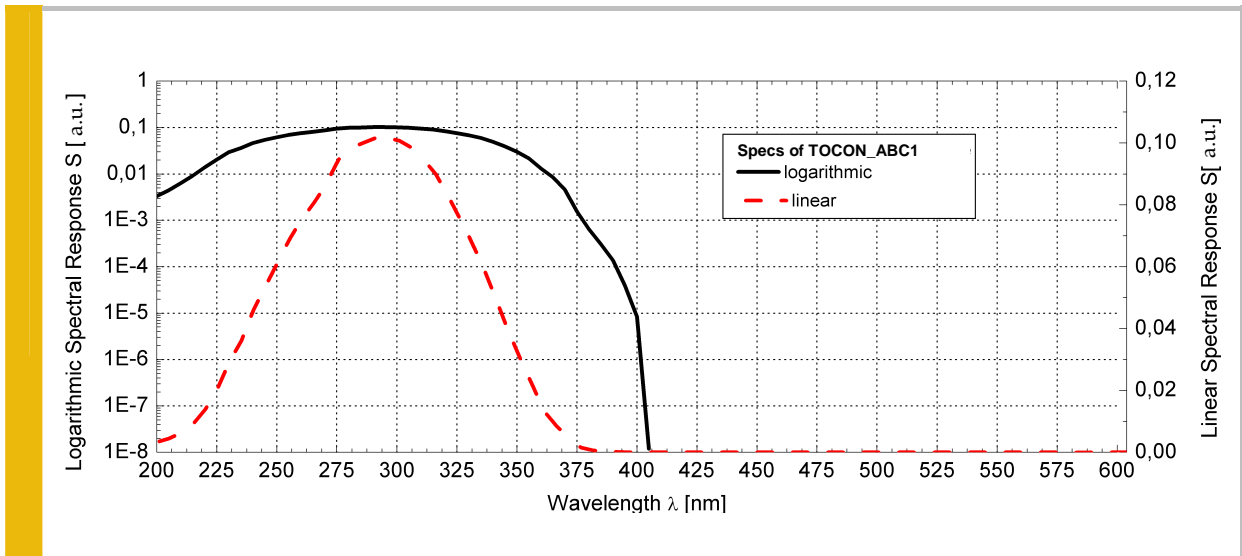

Drawing

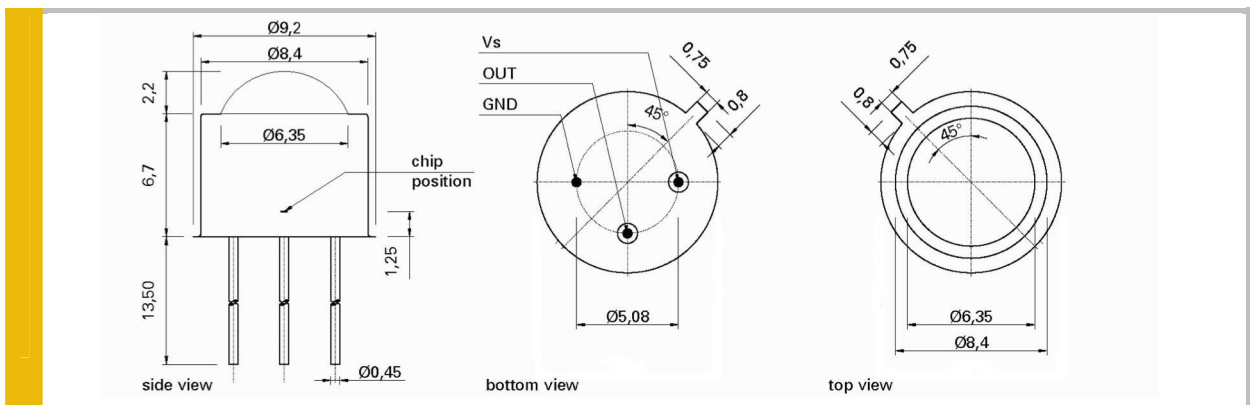

Field of View

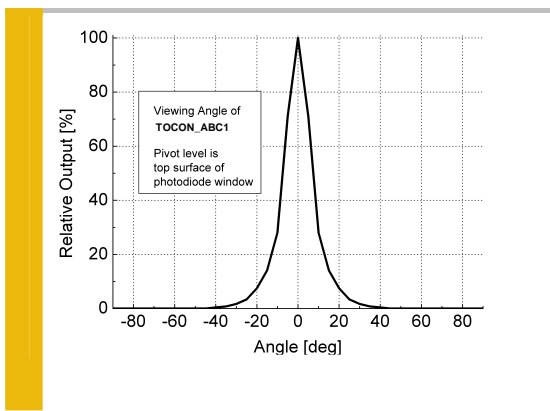

TOCON Product Portfolio

Selection of TOCONs with UV broadband sensitivity:

Option	Approx. min irradiance	Approx. max irradiance (V _{supply} = 5 V)
TOCON_ABC1	1,8 pW/cm ²	18 nW/cm ² <i>this device</i>
TOCON_ABC2	18 pW/cm ²	180 nW/cm ²
TOCON_ABC3	180 pW/cm ²	1,8 μW/cm ²
TOCON_ABC4	1,8 nW/cm ²	18 μW/cm ²
TOCON_ABC5	18 nW/cm ²	180 μW/cm ²
TOCON_ABC6	180 nW/cm ²	1,8 mW/cm ²
TOCON_ABC7	1,8 μW/cm ²	18 mW/cm ²
TOCON_ABC8	18 μW/cm ²	180 mW/cm ²
TOCON_ABC9	180 μW/cm ²	1,8 W/cm ²
TOCON_ABC10	1,8 mW/cm ²	18 W/cm ²

TOCONs are also available with other spectral sensitivity (UVA, UVB, UV-Index, UVC).

Upgrades

TOCON housing for easy mounting of the TOCON_ABC1

TOCON_housing



Advantages of the TOCON_housing

- Easy to mount and connect
- Robust stainless steel M12x1 thread body, length 32 mm
- Integrated sensor connector (Binder 5-Pin plug)
- Comes with 2 m connector cable

Sensor Monitor 5.0 for monitoring, datalogging and process control with TOCON_ABC1



The **Sensor Monitor 5.0** series are measurement and control modules for monitoring and automation of irradiation processes. They display radiation, dose and state information.

A selection of devices with one or two channels, optional USB & RS232 data output and computer software is offered.

UVMICROLOG for datalogging and permanent measurements with TOCON_ABC1



The **UVMICROLOG** is designed for logging of ultraviolet radiation, temperature, pressure and acceleration. Sophisticated microcontroller technology and low noise SiC TOCON based UV detectors allow up to 3 months of permanent measurement and logging without battery charging. The unit can be mounted with a belt or screws.