

# BNC Panel Plug 50R



## Specifications:

Connector Type	: BNC Coaxial
Body Style	: Straight Plug
Impedance	: 50Ω
Contact Material	: Brass
Contact Plating	: Silver
Frequency Max	: 11GHz
Connector Mounting	: Panel
Approval Bodies	: MIL Spec
Contact Resistance	: 1.5mΩ
DC Current Max	: 1A
External Length / Height	: 17.5mm
Fixing Centres	: 12.7mm
Fixing Hole Dia	: 3.2mm
Mounting Type	: Panel
Operating Temperature	: -65°C to +165°C
Proof Voltage	: 2kV
VSWR	: 1.35
Working Voltage	: 500V
Bodies	: Brass per JIS-C3604
Centre Contact	: Brass per JIS-C3604
Insulation	: PTFE per ASTM D1457 and ASTM D1710
Square Flange	: Brass per JIS-C2680
Connector interface per MIL-STD-348A	
Part to be clean and free of burrs	

# BNC Panel Plug 50R

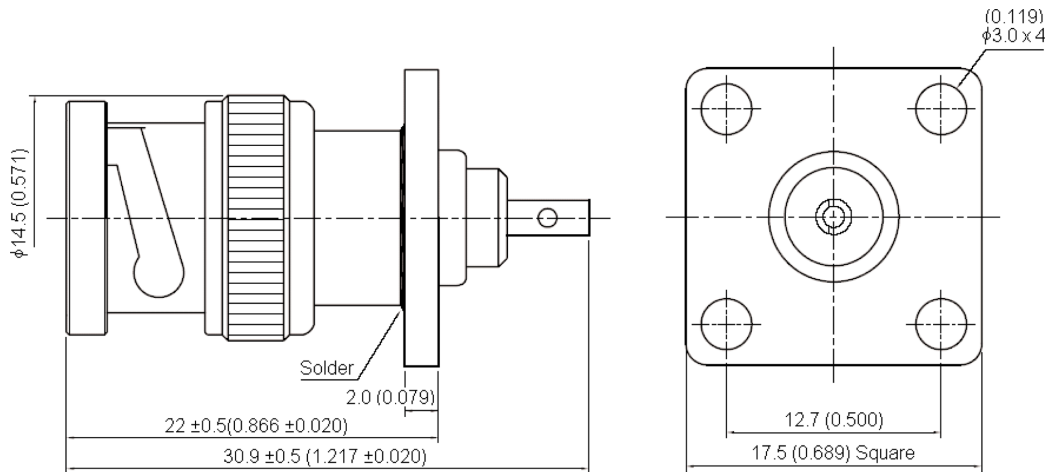

Dimensions : Millimetres (Inches)

Number	Description	Material	Finish
1	Shell	Brass	Silver 70 $\mu$ " Min.
2	Insulation	PTFE	None
3	Gasket	Silicone	Red
4	Washer	Brass	Nickel 100 $\mu$ " Min.
5	Spring Washer	SK-5	
6	Washer	Brass	Silver 70 $\mu$ " Min.
7	Body		
8	Center Contact		
9	Square Flange		

## Part Number Table

Description	Part Number
Plug, BNC, Panel, 50R	13-21-2 TSS 50R

**Important Notice :** This data sheet and its contents (the "Information") belong to the members of the Premier Farnell group of companies (the "Group") or are licensed to it. No licence is granted for the use of it other than for information purposes in connection with the products to which it relates. No licence of any intellectual property rights is granted. The Information is subject to change without notice and replaces all data sheets previously supplied. The Information supplied is believed to be accurate but the Group assumes no responsibility for its accuracy or completeness, any error in or omission from it or for any use made of it. Users of this data sheet should check for themselves the Information and the suitability of the products for their purpose and not make any assumptions based on information included or omitted. Liability for loss or damage resulting from any reliance on the Information or use of it (including liability resulting from negligence or where the Group was aware of the possibility of such loss or damage arising) is excluded. This will not operate to limit or restrict the Group's liability for death or personal injury resulting from its negligence. Multicomp is the registered trademark of the Group. © Premier Farnell plc 2012.

www.element14.com  
www.farnell.com  
www.newark.com

