

# Data Switch

## HD DB15 + 2 PS2, 2 Way

pro-SIGNAL



### Specifications :

Computer Switch Type	: Data
Computer Switch Function	: Manual
Input Connection	: DB15 Female
Output Connection	: PS/2
No. of Ways	: 2

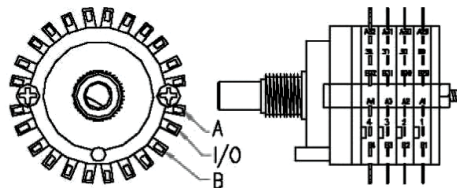
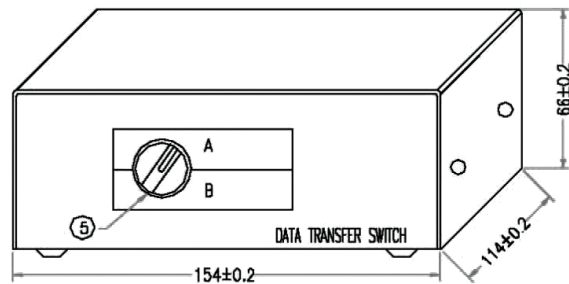
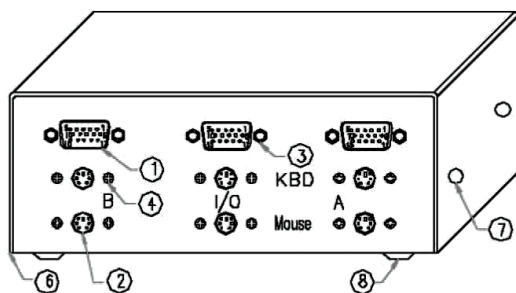

Dimensions : Millimetres

No.	Description	Qty
1	HD15 Female, Gold Flash on Contacts, Blue Insulator	3
2	Mini DIN6 Female, Gold Flash on contacts, Black Insulator	6
3	Hex-Nut 4.75mm × 13mm, Screw Cap 4.75mm × 1.5mm	6 Set
4	Hex-Nut with Screw Cap 3mm × 6mm	12 Set
5	Knob for A, B, Switch	1
	Screw 4mm × 12.5mm With Pad	1 Set
	Main Heart 4-28-2	1
	26AWG Insulator, Length 150mm	89
6	Metal case, Thickness 0.8mm	1 Set
7	Screw 3 × 6 PWB	4
8	Plasto-Visco- Elastic Body	4

# Data Switch

## HD DB15 + 2 PS2, 2 Way

pro-SIGNAL

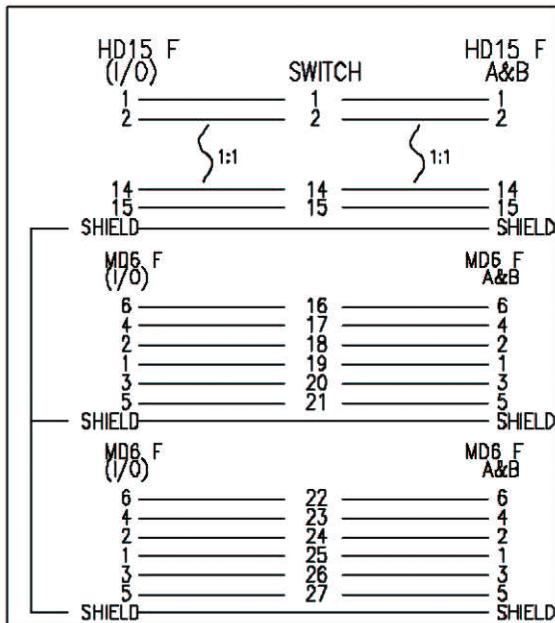

### Part Number Table

Description	Part Number
Data Switch, HD DB15 + 2 PS2, 2 Way	SB702

**Important Notice :** This data sheet and its contents (the "Information") belong to the members of the Premier Farnell group of companies (the "Group") or are licensed to it. No licence is granted for the use of it other than for information purposes in connection with the products to which it relates. No licence of any intellectual property rights is granted. The Information is subject to change without notice and replaces all data sheets previously supplied. The Information supplied is believed to be accurate but the Group assumes no responsibility for its accuracy or completeness, any error in or omission from it or for any use made of it. Users of this data sheet should check for themselves the Information and the suitability of the products for their purpose and not make any assumptions based on information included or omitted. Liability for loss or damage resulting from any reliance on the Information or use of it (including liability resulting from negligence or where the Group was aware of the possibility of such loss or damage arising) is excluded. This will not operate to limit or restrict the Group's liability for death or personal injury resulting from its negligence. pro-SIGNAL is the registered trademark of the Group. © Premier Farnell plc 2012.

www.element14.com  
 www.farnell.com  
 www.newark.com  
 www.cpc.co.uk

pro-SIGNAL