

PHYSICAL DIMENSIONS:

A	7.62 [.300]	+ 0.13 [.005]
B	8.13 [.320]	+ 0.13 [.005]
B ₁	10.92 [.430]	MAX
C	5.72 [.225]	+ 0.10 [.004]
C ₁	6.35 [.250]	MAX
D	4.06 [.160]	+ 0.05 [.002]
E	1.27 [.050]	+ 0.13 [.005]
E ₁	2.03 [.080]	+ 0.13 [.005]

WIRE DIMENSIONS:

T ₁	3.30 [.130]	+ 0.38 [.015]
T ₂	0.64 [.025]	TYP.
T ₃	0.38 [.015]	TYP.

CM3032V121R-10

UNCONTROLLED DOCUMENT

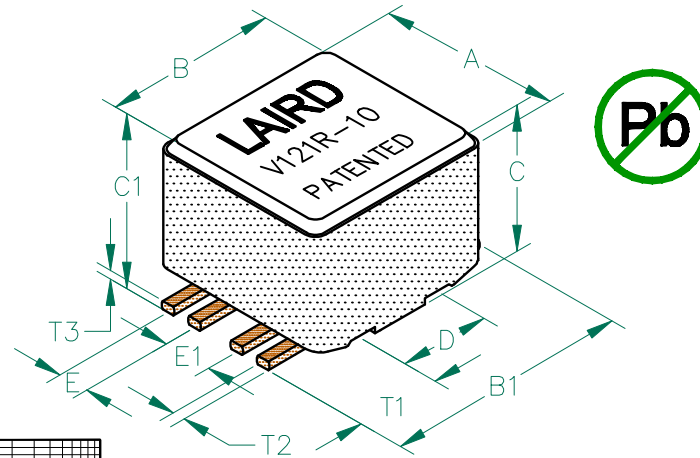

ELECTRICAL CHARACTERISTICS:

Z @ 100MHz (Ω)	DCR (Ω)	Rated Current	Rated Voltage (VDC)
Nominal	120		
Minimum	90		
Maximum	150	0.01	8,000 mA
			30

NOTES: UNLESS OTHERWISE SPECIFIED

1. TAPED AND REELED per CURRENT EIA SPECIFICATIONS 13" REELS, 400 PCS/REEL.
2. COMPONENTS SHOULD BE ADEQUATELY PREHEATED BEFORE SOLDERING.
3. REF. CARRIER TAPE SPECIFICATION # CART3032-13.
4. TERMINATION FINISH IS 100% TIN.
5. THIS PART HAS NO PIN POLARITY.
6. OPERATION TEMPERATURE (INCLUDING SELF-HEATING): -40 ~ +125°C.

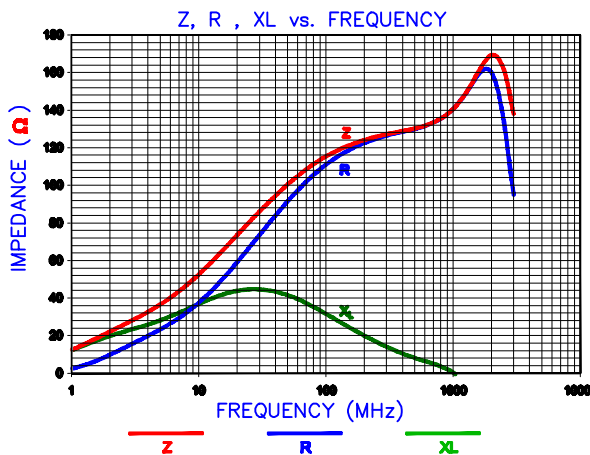
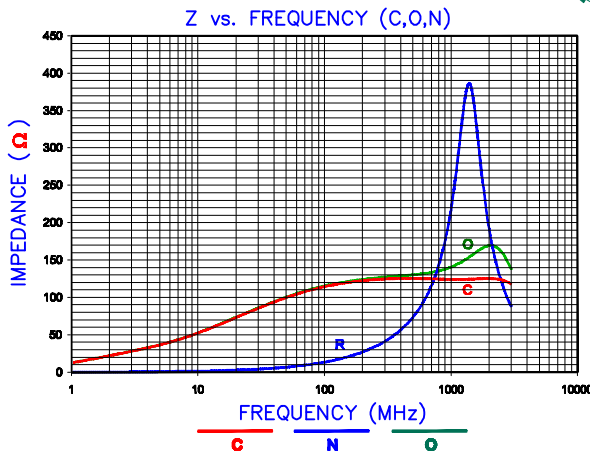

LAND PATTERNS FOR REFLOW SOLDERING

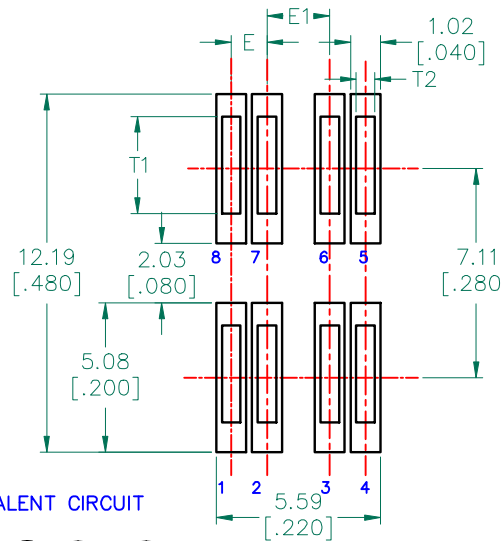

EQUIVALENT CIRCUIT

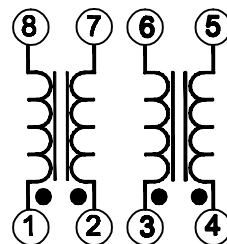

RECOMMENDED SOLDERING CONDITIONS

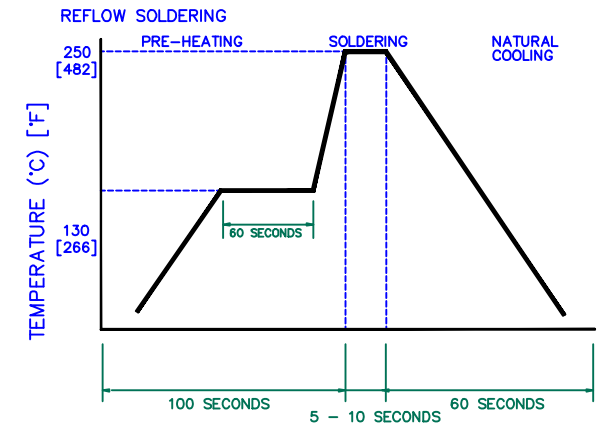

DIMENSIONS ARE IN mm (INCHES).

This print is the property of Laird Tech. and is loaned in confidence subject to return upon request and with the understanding that no copies shall be made without the written consent of Laird Tech. All rights to design or invention are reserved.



D	ADD RATED VOLTAGE AND NOTE 6	08/30/12	QIU	PROJECT/PART NUMBER:	REV	PART TYPE:	DRAWN BY:
C	UPDATE LOGO, KAPTON LABEL ADD EC	11/06/08	JRK	CM3032V121R-10	D	CO-FIRE	JRK
B	UPDATE COMPANY LOGO	11/21/07	JRK	DATE:	SCALE:	NTS	SHEET:
A	ORIGINAL DRAFT	06/16/04	JRK	06/16/04			
REV	DESCRIPTION	DATE	INT	CAD #	TOOL #	-	2 of 3
				CM3032V121R-10-D-2			

SCALE DRAWING

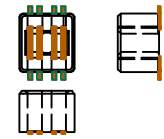

CM3032V121R-10

UNCONTROLLED DOCUMENT



ELECTRICAL TESTING

	<u>GROSS</u>	<u>GROSS</u>
TEST:	Z	Z
# TURNS	1	1
AWG	22	22
FREQUENCY	25 MHz	100 MHz
NOMINAL	68 Ω	120 Ω
MINIMUM	51 Ω	90 Ω
MAXIMUM	- Ω	150 Ω
WEIGHT/1000	1.44 kgs.	3.17 lbs.

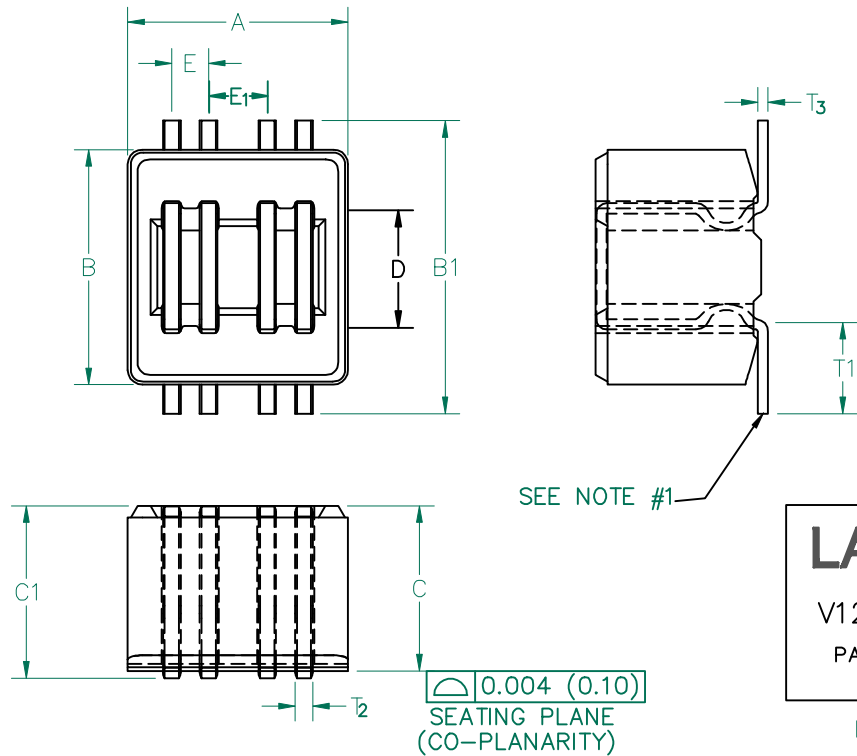

LAIRD
V121R-10
PATENTED

LABEL

DIMENSIONS:

A	7.62 [.300]	± 0.13 [.005]
B	8.13 [.320]	± 0.13 [.005]
B1	10.92 [.430]	MAX
C	5.72 [.225]	± 0.10 [.004]
C1	6.35 [.250]	MAX
D	4.06 [.160]	± 0.05 [.002]
E	1.27 [.050]	± 0.13 [.005]
E1	2.03 [.080]	± 0.13 [.005]

WIRE DIMENSIONS:

T1	3.30 [.130]	± 0.38 [.015]
T2	0.64 [.025]	TYP.
T3	0.38 [.015]	TYP.

NOTES: UNLESS OTHERWISE SPECIFIED

1. WIRE: REFERENCE STEWARD WIRE PURCHASE SPEC. W0032-11
2. IMPEDANCE VALUES ARE GROSS, MEASURED USING W0032-11 WIRE PLACED AGAINST END OF SLOT w/ NO D.C. BIAS.
3. REFERENCE STEWARD CORE P/N 24H0300-100.
4. PROTECTED BY U.S. PATENT NO. 5,455,552.
5. TERMINATION FINISH IS 100% TIN.
6. THIS PART HAS NO PIN POLARITY.

DIMENSIONS ARE IN mm (INCHES).				This print is the property of Laird Tech. and is loaned in confidence subject to return upon request and with the understanding that no copies shall be made without the written consent of Laird Tech. All rights to design or invention are reserved.		Laird TECHNOLOGIES	
D	ADD RATED VOLTAGE AND NOTE 6	08/30/12	QIU	PROJECT/PART NUMBER:	REV	PART TYPE:	DRAWN BY:
C	UPDATE COMPANY LOGO AND KAPTON LABEL ADD EQUIV. CIRCUIT	11/05/08	JRK	CM3032V121R-10	D	CO-FIRE	JRK
B	UPDATE COMPANY LOGO	11/21/07	JRK	DATE:	SCALE:	NTS	SHEET:
A	ORIGINAL DRAFT	06/16/04	JRK	06/16/04			
REV	DESCRIPTION	DATE	INT	CAD #	TOOL #		
				CM3032V121R-10-D-3	H0300-100		3 of 3