

PHYSICAL DIMENSIONS:

A	6.30 [.248]	+ 0.10 [.004]
B	11.38 [.448]	+ 0.18 [.007]
B1	14.10 [.555]	MAX
C	9.32 [.367]	+ 0.18 [.007]
C1	10.16 [.400]	MAX
D	7.62 [.300]	+ 0.10 [.004]
E	2.54 [.100]	+ 0.13 [.005]

WIRE DIMENSIONS:

T1	2.90 [.114]	- 0.25 [.010]
T2	0.84 [.033]	TYP.
T3	0.46 [.018]	TYP.

Z vs. FREQUENCY (C,O,N)

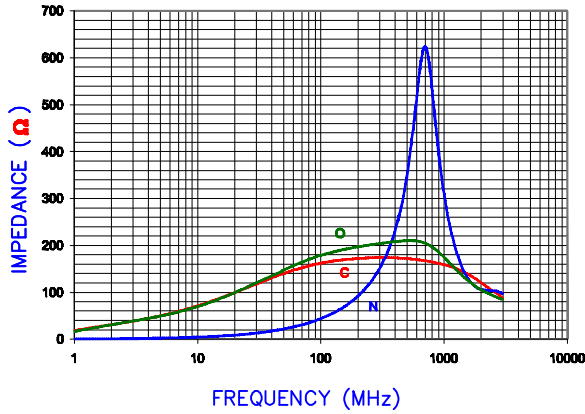

FREQUENCY (MHz)
Z, R, XL vs. FREQUENCY

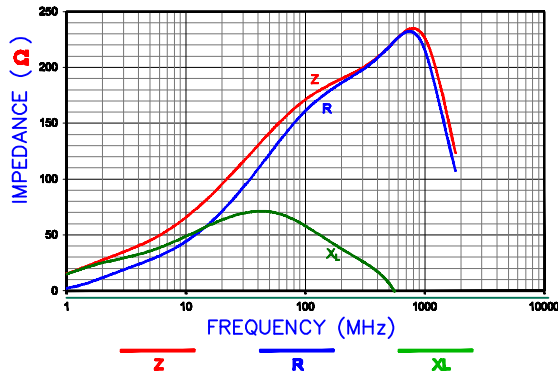

CM2545X171R-10

UNCONTROLLED DOCUMENT

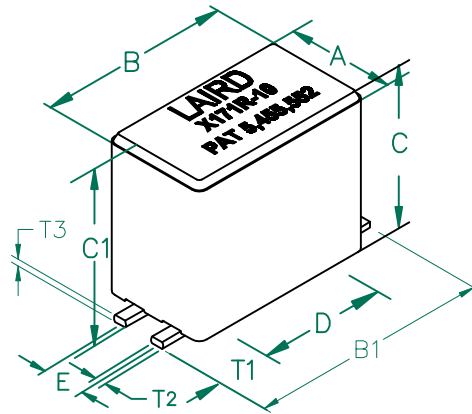

ELECTRICAL CHARACTERISTICS:

Z @ 100MHz (Ω)	DCR (Ω)	Rated Current	Rated Voltage (VDC)
Nominal	170		
Minimum	128		
Maximum	-	0.01	10,000 mA
			140

NOTES: UNLESS OTHERWISE SPECIFIED

1. TAPED AND REELED per CURRENT EIA SPECIFICATIONS 13" REELS, 400 PCS/REEL.
2. COMPONENTS SHOULD BE ADEQUATELY PREHEATED BEFORE SOLDERING.
3. REF. CARRIER TAPE SPEC. # CART249-63.
4. TERMINATION FINISH IS 100% TIN.
5. THIS PART HAS NO PIN POLARITY.
6. OPERATION TEMPERATURE (INCLUDING SELF-HEATING): -40 ~ +125°C.



LAND PATTERN FOR REFLOW SOLDERING

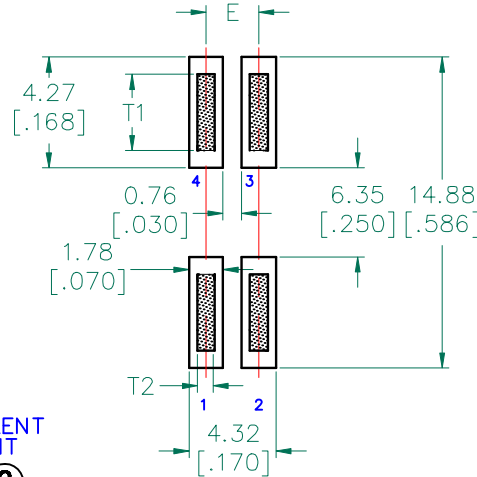

RECOMMENDED SOLDERING CONDITIONS

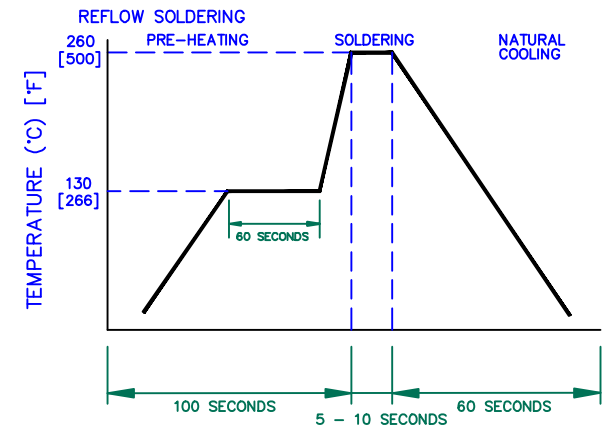

EQUIVALENT CIRCUIT

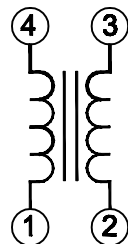

DIMENSIONS ARE IN mm [INCHES]				This print is the property of Laird Tech. and is loaned in confidence subject to return upon request and with the understanding that no copies shall be made without the written consent of Laird Tech. All rights to design or invention are reserved.	
F	ADD RATED VOLTAGE AND NOTE 6	08/30/12	QU		
E	UPDATE THE SOLDERING TEMPERATURE	03/24/11	JUN		
D	ADD C1 IN CONFIGURATION	12/02/09	JUN		
C	UPDATE COMPANY LOGO UPDATE ROHS SYMBOL AND KAPTON LABEL ADD EC	11/05/08	JRK		
PROJECT/PART NUMBER: CM2545X171R-10				REV: F	DRAWN BY: JRK
B	UPDATE COMPANY LOGO	05/18/07	JRK	DATE: 5/26/04	SCALE: NTS
A	ORIGINAL DRAFT	5/26/04	JRK	CAD #	TOOL #
REV	DESCRIPTION	DATE		CM2545X171R-10-F-2	H0249-600

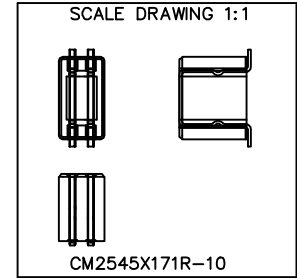
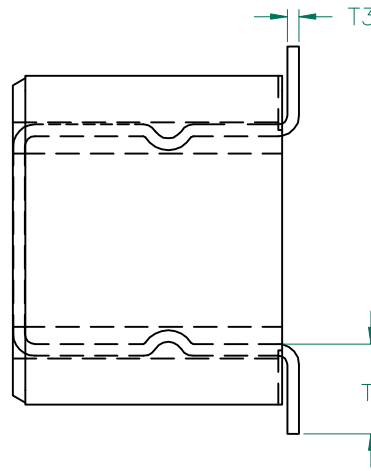
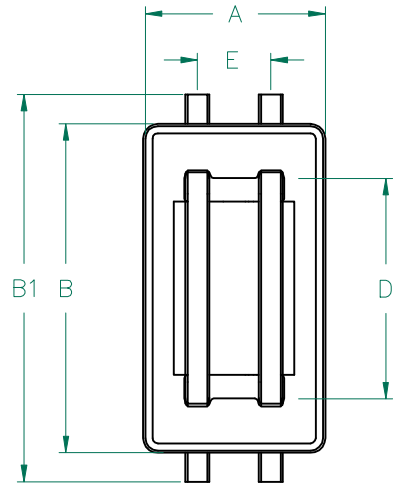

UNCONTROLLED DOCUMENT

ELECTRICAL TESTING

TEST:	GROSS	GROSS
	Z	Z
# TURNS	1	1
AWG	22	22
FREQUENCY	25 MHz	100 MHz
NOMINAL	70 Ω	170 Ω
MINIMUM	53 Ω	128 Ω
MAXIMUM	- Ω	- Ω
WEIGHT/1000	2.94 kgs.	6.48 lbs.

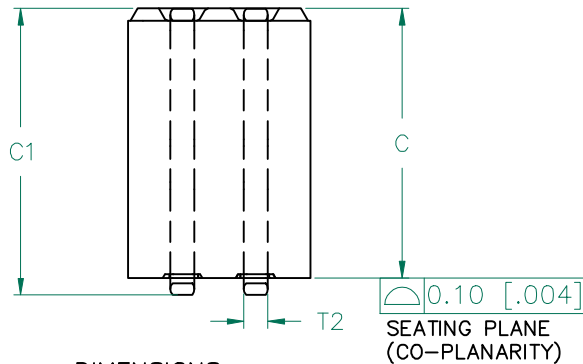

LAIRD
X171R-10
PAT 5,455,552



NOTES: UNLESS OTHERWISE SPECIFIED

1. WIRE: REFERENCE STEWARD WIRE PURCHASE SPEC. W0449-61.
2. IMPEDANCE VALUES ARE GROSS, MEASURED USING W0449 WIRE PLACED AGAINST END OF SLOT w/ NO D.C. BIAS.
3. REFERENCE STEWARD CORE P/N 29H0249-600.
4. PROTECTED BY U.S. PATENT NO. 5,455,552.
5. TERMINATION FINISH IS 100% TIN.
6. THIS PART HAS NO PIN POLARITY.

DIMENSIONS:

A	6.30 [.248]	+	0.10 [.004]
B	11.38 [.448]	+	0.18 [.007]
B1	14.10 [.555]		MAX
C	9.32 [.367]	+	0.18 [.007]
C1	10.16 [.400]		MAX
D	7.62 [.300]	+	0.10 [.004]
E	2.54 [.100]	+	0.13 [.005]

WIRE DIMENSIONS:

T1	2.90 [.114]	+	0.25 [.010]
T2	0.84 [.033]		TYP.
T3	0.46 [.018]		TYP.

DIMENSIONS ARE IN mm [INCHES].				This print is the property of Laird Tech. and is loaned in confidence subject to return upon request and with the understanding that no copies shall be made without the written consent of Laird Tech. All rights to design or invention are reserved.		Laird TECHNOLOGIES	
F	ADD RATED VOLTAGE AND NOTE 6	08/30/12	QIU	PROJECT/PART NUMBER:		REV	DRAWN BY:
E	UPDATE THE SOLDERING TEMPERATURE	03/24/11	JUN	CM2545X171R-10		F	JRK
D	ADD C1 IN CONFIGURATION	12/02/09	JUN	DATE:	5/26/04	SCALE:	NTS
C	UPDATE COMPANY LOGO UPDATE ROHS SYMBOL AND KAPTON LABEL ADD EC	11/05/08	JRK	CAD #	CM2545X171R-10-F-3	TOOL #	H0249-600
B	UPDATE COMPANY LOGO	05/18/07	JRK	SHEET:		3 of 3	
A	ORIGINAL DRAFT	5/26/04	JRK				
REV	DESCRIPTION	DATE					