

CM0805C221R-10

UNCONTROLLED DOCUMENT

PHYSICAL DIMENSIONS:

A	2.00 [.079]	+ 0.20 [.008]
B	1.20 [.047]	+ 0.20 [.008]
C	1.20 [.047]	+ 0.20 [.008]
D	0.15 [.006]	+ 0.10 [.004]

T1	0.55 [.022]	+ 0.10 [.004]
T2	0.46 [.018]	+ 0.10 [.004]

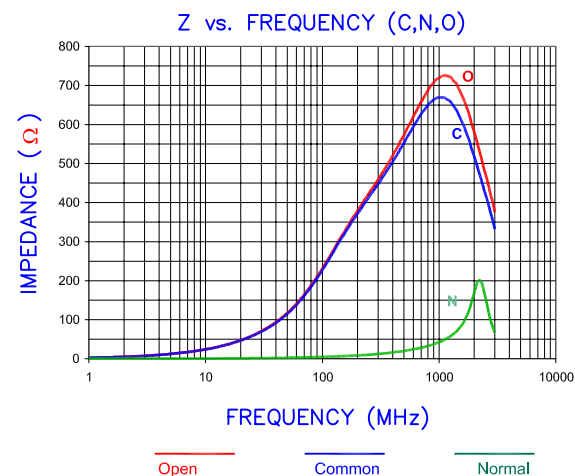
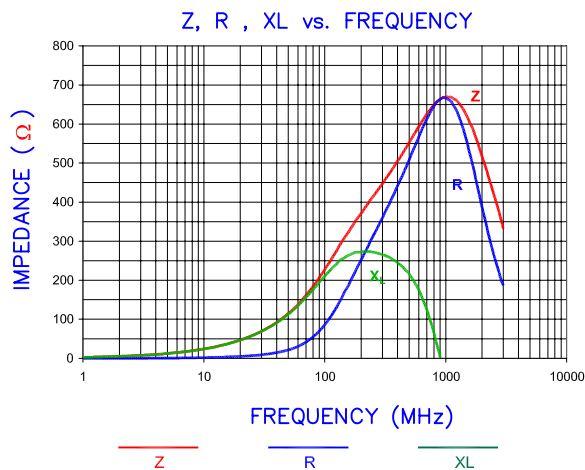
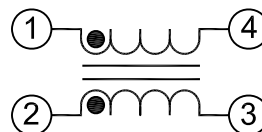
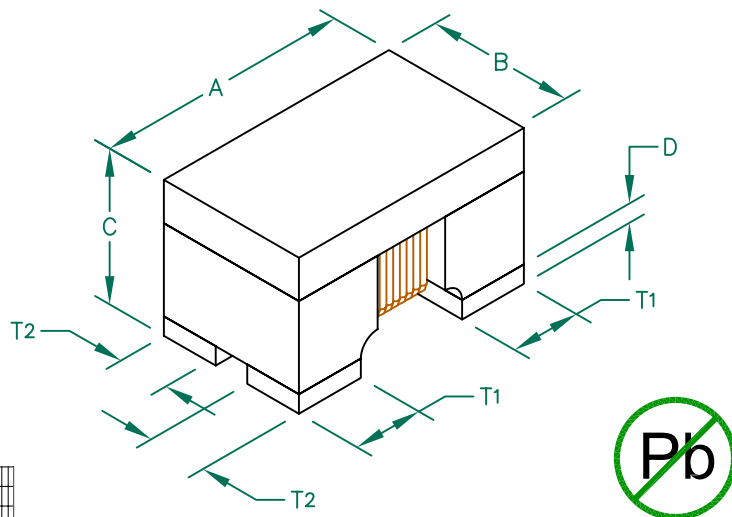

LAND PATTERNS FOR REFLOW SOLDERING

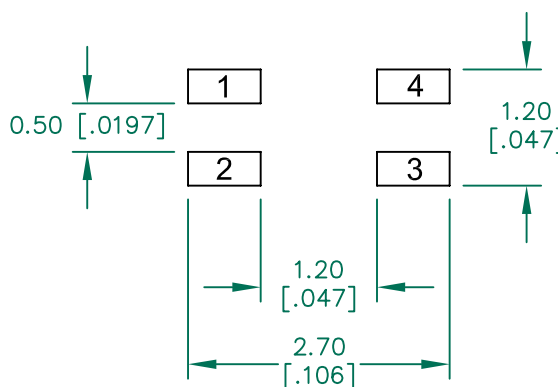

Electrical Characteristics		Nominal	Min	Max
Common Mode Impedance @ 100MHz	(Ω)	220	165	275
DCR	(Ω)	-	-	0.4
Rated Current	(mA)	-	-	300

NOTES: UNLESS OTHERWISE SPECIFIED

1. TAPED AND REELED per CURRENT EIA SPECIFICATIONS 7" REELS, EMBOSSED PLASTIC TAPE 2,000 PCS/REEL.
2. TERMINATION FINISH 100% MATTE TIN.
3. COMPONENTS SHOULD BE ADEQUATELY PREHEATED BEFORE SOLDERING.

RECOMMENDED SOLDERING CONDITIONS

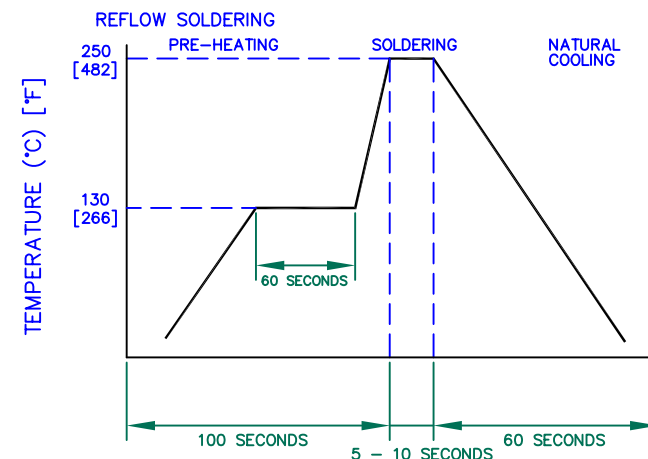

DIMENSIONS ARE IN mm [INCHES].				This print is the property of Laird Tech. and is loaned in confidence subject to return upon request and with the understanding that no copies shall be made without the written consent of Laird Tech. All rights to design or invention are reserved.			Laird TECHNOLOGIES®	
D	UPDATE T1 AND T2	01/15/10	JUN	PROJECT/PART NUMBER:	REV	PART TYPE:	DRAWN BY:	
C	UPDATE COMPANY LOGO	04/28/09	JRK	CM0805C221R-10	D	CM CHOKE	JRK	
B	UPDATE COMPANY LOGO	05/10/07	JRK	DATE:	SCALE:	NTS	SHEET:	
A	ORIGINAL DRAFT	08/11/06	JRK	08/11/06				
REV	DESCRIPTION	DATE	INT	CAD #	TOOL #			
				CM0805C221R-10-D	-		2 of 2	