



# GPS Receivers A2100-A/B

A Description of Maestro's  
GPS Receiver Module A2100-A/B

## User's Manual

Version 1.9



## Revision History

Rev.	Date	Description
0.1	08-24-09	First draft, based on A1084 V1.1
0.2	01-25-10	RoHS, pin-out, clean-up, ...
0.3	01-29-10	nWAKEUP correction, new pictures, ON_OFF correction, BOOTSEL correction
0.4	02-11-10	Minimum configuration updated (!), ON_OFF voltage in 6.3 DC characteristics corrected
0.5	02-12-10	New title picture, updated label information
0.6	03-09-10	Included A2100-B; additional Minimum configuration for active antenna, emphasized that VANT is an input
0.7	04-15-10	Label correction; adaptations after firmware 4.0.1 release; others ...
0.8	02-09-11	1.Shutdown sequence introduced; more figures defined; smaller corrections 2. New style; moved to Maestro
1.1	05-04-11	1.Order number correction 2. Modify MEMS details 3. Modify packaging describe
1.2	05-17-11	1.Tracking current updated
1.3	06-03-11	1.Correction of Mechanical Characteristics
1.4	10-28-11	1.Updated Table 6&7: A2100-A/B electrical characteristics 2.Add sensor description
1.5	01-04-12	Add describe of the EVA2100-B
1.6	03-01-12	1.Add Firmware Updates information
1.7	05-24-12	1. Updated of the antenna Gain, 2. link to 1PPS application note and 1PPS timing accuracy remarks added, 3.Recommended Solder PAD Layout drawing added.
1.8	06-01-12	Update nRST pin description
1.9	07-25-12	Add 5Hz Navigation Update Rate and I2C interface of A2100-B
	mm-dd-yy	

	Name	Date	Signature
Written by	Happy wen	07-25-12	H W
Checked by	Sam Law, Matthieu	07-25-12	S L,M
Approval by	Frank Tang, Calvin Yau	07-25-12	F T,C Y

## Disclaimer

THIS DOCUMENT CONTAINS PROPRIETARY INFORMATION OF MAESTRO WIRELESS SOLUTIONS LIMITED. IT MAY NOT BE COPIED OR TRANSMITTED BY ANY MEANS, PASSED TO OTHERS, OR STORED IN ANY RETRIEVAL SYSTEM OR MEDIA, WITHOUT PRIOR CONSENT OF MAESTRO OR ITS AUTHORIZED AGENTS.

THE INFORMATION IN THIS DOCUMENT IS, TO THE BEST OF OUR KNOWLEDGE, ENTIRELY CORRECT. HOWEVER, MAESTRO CAN NEITHER ACCEPT LIABILITY FOR ANY INACCURACIES, OR THE CONSEQUENCES THEREOF, NOR FOR ANY LIABILITY ARISING FROM THE USE OR APPLICATION OF ANY CIRCUIT, PRODUCT, OR EXAMPLE SHOWN IN THE DOCUMENT.

THE PRODUCT (HARD- AND SOFTWARE) DESCRIBED IN THIS DOCUMENTATION IS NOT AUTHORIZED FOR USE IN LIFE SUPPORT DEVICES OR SYSTEMS WITHOUT THE EXPRESS WRITTEN APPROVAL OF MAESTRO.

THIS DOCUMENT MAY PROVIDE LINKS TO OTHER WORLD WIDE WEB SITES OR RESOURCES. BECAUSE MAESTRO HAS NO CONTROL OVER SUCH SITES AND RESOURCES, MAESTRO SHALL NOT BE RESPONSIBLE FOR THE AVAILABILITY OF SUCH EXTERNAL SITES OR RESOURCES, AND DOES NOT ENDORSE AND IS NOT RESPONSIBLE OR LIABLE FOR ANY CONTENT, ADVERTISING, PRODUCTS, OR OTHER MATERIALS ON OR AVAILABLE FROM SUCH SITES OR RESOURCES. MAESTRO SHALL NOT BE RESPONSIBLE OR LIABLE, DIRECTLY OR INDIRECTLY, FOR ANY DAMAGE OR LOSS CAUSED OR ALLEGED TO BE CAUSED BY OR IN CONNECTION WITH USE OF OR RELIANCE ON ANY SUCH CONTENT, GOODS OR SERVICES AVAILABLE ON OR THROUGH ANY SUCH SITE OR RESOURCE.

MAESTRO RESERVES THE RIGHT TO CHANGE, MODIFY, OR IMPROVE THIS DOCUMENT OR THE PRODUCT DESCRIBED HEREIN, AS SEEN FIT BY MAESTRO WITHOUT FURTHER NOTICE.

## Table of Contents

<b>1 Introduction</b> .....	<b>6</b>
1.1 Feature Overview .....	6
1.2 Characteristics Overview .....	7
1.3 RoHS and Lead-Free Information .....	7
1.4 Label .....	8
1.5 Characteristics .....	9
1.5.1 GPS Characteristics .....	9
1.5.2 Mechanical Characteristics.....	9
1.6 Handling Precautions .....	9
<b>2 Ordering Information</b> .....	<b>10</b>
2.1 GPS Receivers A2100-A/B .....	10
2.2 Packing of the A2100-A/B .....	10
2.3 Additional Equipment .....	13
<b>3 Quick Start</b> .....	<b>14</b>
3.1 Minimum Configuration .....	14
3.2 Antennas .....	15
3.2.1 Passive Antennas.....	15
3.2.2 Active Antennas.....	15
3.3 Serial Port Settings .....	16
3.4 Improved TTFB .....	16
3.5 Firmware Updates(Flash-based module only) .....	16
<b>4 Mechanical Outline</b> .....	<b>17</b>
4.1 Details Component Side A2100-A / B .....	17
4.2 Details Solder Side A2100-A/B .....	18
<b>5 Pin-out Information</b> .....	<b>19</b>
5.1 Layout A2100-A .....	19
5.2 Description A2100-A Signals .....	20
5.3 Layout A2100-B .....	21
5.4 Description A2100-B Signals .....	22
<b>6 Electrical Characteristics</b> .....	<b>24</b>
6.1 Operating Conditions .....	24
6.2 Absolute Maximum Ratings .....	25
6.3 DC Electrical Characteristics.....	26
<b>7 Mounting</b> .....	<b>27</b>
7.1 Proposed Footprint for Soldering .....	27
7.2 Recommended Profile for Reflow Soldering .....	28
<b>8 Use of GPS Antennas</b> .....	<b>29</b>
8.1 Connecting a GPS antenna to the GPS receiver .....	29
8.2 Antenna Connections.....	31
8.2.1 Passive Antennas.....	31

8.2.2 Active Antennas.....	31
<b>9 Quality and Reliability.....</b>	<b>32</b>
9.1 Environmental Conditions .....	32
9.2 Product Qualification .....	32
9.3 Production Test.....	32
<b>10 Applications and Hints .....</b>	<b>33</b>
10.1 Initial Module Start .....	33
10.2 Proper Shutdown .....	33
10.3 SiRFaware™ Support .....	33
10.4 Push-to-Fix Mode.....	33
10.5 Hibernate Mode.....	34
10.6 Extended Ephemeris.....	34
10.7 Antenna Status Adaptation .....	35
10.7.1 Antenna Sensor.....	35
10.7.2 Antenna Sensor with Current Limiter.....	36
10.8 VANT Pin .....	37
10.9 TM_GPIO5 pin (1 pulse per second pin).....	37
10.10 5 Hz Navigation Update Rate.....	38
<b>11 Evaluation Kit EVA2100-A/B .....</b>	<b>39</b>
<b>12 Related Information .....</b>	<b>40</b>
12.1 Contact.....	40
12.2 Related Documents.....	40
12.3 Related Tools .....	40
<b>13 List of Figures .....</b>	<b>41</b>
<b>14 List of Tables .....</b>	<b>41</b>

## 1 Introduction

The GPS modules A2100-A and A2100-B are Maestro's first implementation of CSR's SiRFstarIV chip on GPS modules. Both are highly integrated GPS receivers that can be used as SMT components. A very easy implementation (power, serial, ON\_OFF, and antenna) allows receiving position, velocity and time information.

**NOTE:** Care must be taken to implement an orderly shut-down sequence along with supplying power for a certain period of time after initiating the shut-down sequence. Abrupt removal or drop of power while the module is running has risks ranging from minor impact on TTFF to fatal, permanent corruption of flash memory code area!

While the A2100-A is a module designed for a 3.3V environment, the A2100-B works with 1.8V Vcc and 1.8V I/Os.

### 1.1 Feature Overview

The A2100-A and A2100-B are based on the well-established A1084 outline and offer new, outstanding features.

- Fast, responsive location experience
  - High-sensitive navigation engine with tracking down to -163dBm
  - 48 track verification channels
  - SBAS (WAAS, EGNOS, MSAS, GAGAN)
- Breakthrough micro power technology
  - Requires only 50 – 500 $\mu$ A to maintain hot start capability
- Active jammer remover
  - Removes in-band jammers up to 80dB/Hz
  - Tracks up to eight CW (continuous wave) jammers

## 1.2 Characteristics Overview

The module's most important characteristics are:

- A2100-A
  - Operable at 3.3V / 19mA (typ.) @ 1 fix per second
  - UART interface at 3.3V CMOS level
  - SPI Slave support at 3.3V CMOS level
- A2100-B
  - Operable at 1.8V / 30mA (typ.) @ 1 fix per second
  - UART interface at 1.8V CMOS level
  - SPI Slave support at 1.8V CMOS level
  - I2C Master support at 1.8V CMOS level
- Direct passive antenna support
- Switched antenna voltage for active antenna support
- Small form factor of 15.24 mm x 15.24 mm (0.6" x 0.6")
- Supported temperature range: -40°C to +85°C
- Single-sided SMT component, for reflow soldering
- Tape & reel packaging

The A2100-A and A2100-B receiver modules are available as off-the-shelf components, 100% tested and shipped in standard tape-and-reel package.

## 1.3 RoHS and Lead-Free Information

Maestro's products marked with the lead-free symbol either on the module or the packaging comply with the "Directive 2002/95/EC of the European Parliament and the Council on the Restriction of Use of certain Hazardous Substances in Electrical and Electronic Equipment" (RoHS).



All Maestro GPS receiver modules, smart GPS antenna modules and telematics units are RoHS compliant.

## 1.4 Label

The A2100-A labels hold the following information:



Figure 1: A2100-A label

The label is placed on the shield of the module. The data matrix code holds the product type, software version, software release, hardware release, factory code, year & week of assembly and a 6-digit serial number. The A2100-B's labels show a "B" instead of the "A", e.g. "A2100-B405-01-01".

**NOTE:** Hardware revision (rr) of the series product starts with 01. A hardware revision above 50 shows the module was produced before the product was fully qualified (Engineering Samples).



## 1.5 Characteristics

The modules are characterized by the following parameters.

### 1.5.1 GPS Characteristics

Channels		48, parallel tracking
Correlators		~ 400,000
Frequency		L1 (= 1,575 MHz)
Tracking Sensitivity <sup>(1)</sup>		-163 dBm
Horizontal Position Accuracy	Stand alone	< 2.5 m CEP (SA off)
Time To First Fix – TTFF (theoretical minimum values; values in real world may differ)	Obscuration recovery <sup>(2)</sup>	0.1 s
	Hot start <sup>(3)</sup>	< 1 s
	Warm <sup>(4)</sup>	< 32 s
	Cold <sup>(5)</sup>	< 35 s

Table 1: A2100-A/B GPS characteristics

- (1) Typical with good antenna – see also paragraph “3.2 Antennas”
- (2) The calibrated clock of the receiver has not stopped, thus it knows precise time (to the  $\mu$ s level).
- (3) The receiver has estimates of time/date/position and valid almanac and ephemeris data.
- (4) The receiver has estimates of time/date/position and recent almanac.
- (5) The receiver has no estimate of time/date/position, and no recent almanac.

Note: Performance (sensitivity and TTFF) might slightly decrease below  $-30^{\circ}\text{C}$ .

### 1.5.2 Mechanical Characteristics

A2100-A/B Mechanical dimensions	Length	15.24 $\pm$ 0.20 mm, 0.6 $\pm$ 0.008”
	Width	15.24 $\pm$ 0.20 mm, 0.6 $\pm$ 0.008”
	Height	2.9 mm, 0.115” (Max)
A2100-A/B Weight		1.2 g, 0.042 oz

Table 2: A2100-A/B dimensions and weight

## 1.6 Handling Precautions

The GPS receiver module A2100-A/B is sensitive to electrostatic discharge (ESD). Please handle with appropriate care.

## 2 Ordering Information

### 2.1 GPS Receivers A2100-A/B

The order number is built as follows:

- **A2100-Axxx**
- **A2100-Bxxx**

A2100-A for the A2100-A module and A2100-B for the A2100-B module. The “xxx” refers to the current firmware version on the module. If no firmware version is referenced in an order, the latest version will be provided.

### 2.2 Packing of the A2100-A/B

The A2100-A/B GPS modules come in a tape and reel package suitable for pick and place machines.

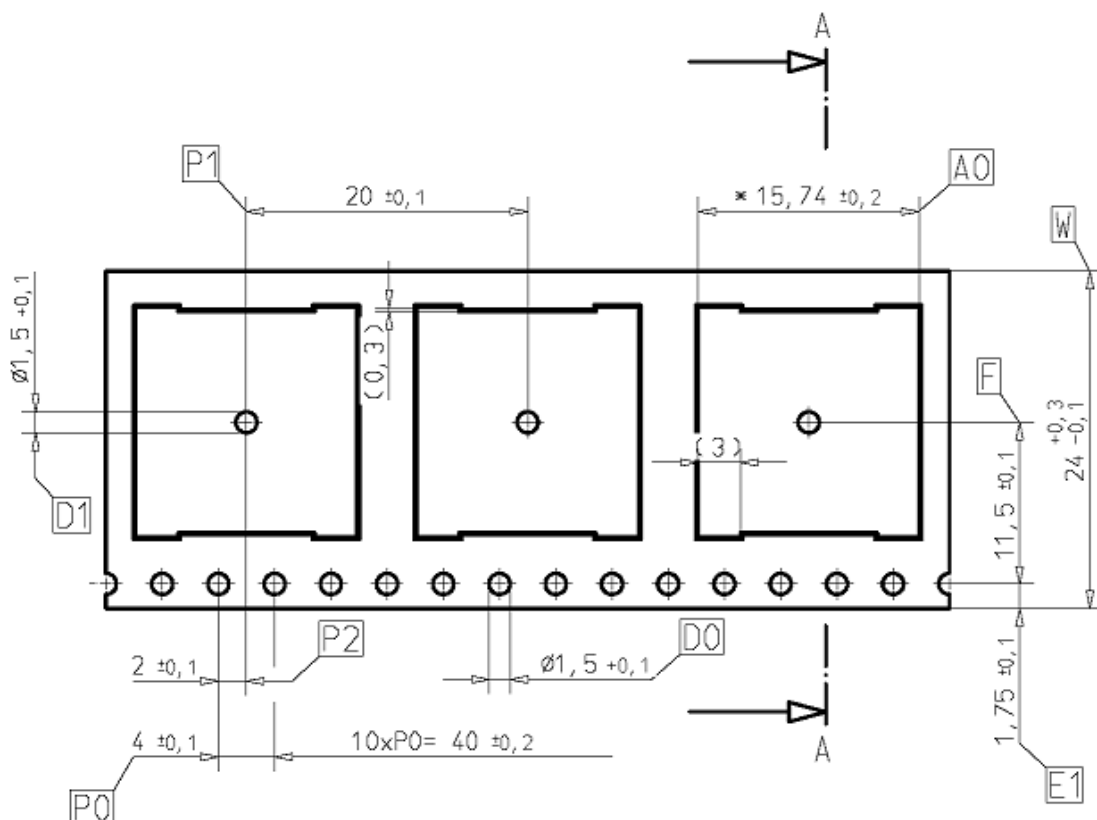

Figure 2: A2100-A/B tape specifications (1)

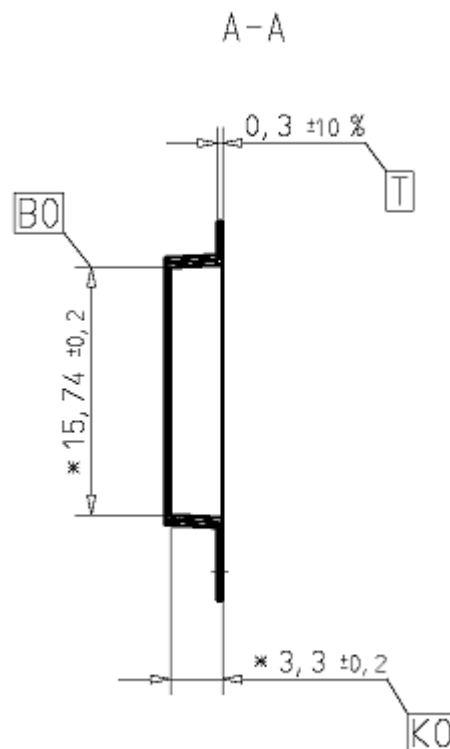

Figure 3: A2100-A/B tape specifications (2)

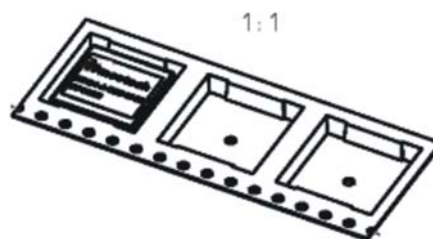

Figure 4: A2100-A/B tape specifications (3)

One complete reel holds 900 A2100-A/B modules.

There are 2 kinds of packaging for shipment:

A: One box holds 1 reel

Reel diameter: 33 cm

Inner box dimensions: 36(W) x 36(L) x 4.5 (H) cm

Box dimensions: 38.8 (W) x 38.8 (L) x 5.7 (H) cm

Gross weight: 2.05 Kg

Net weight: 1.17 Kg

B. One box holds 3 reels

Reel diameter: 33 cm

Inner box dimensions: 36 (W) x 36 (L) x 4.5 (H) cm

Outer box dimensions: 38 (W) x 38 (L) x 16 (H) cm

Gross weight: 6.13 Kg

Net weight: 3.51 Kg

## 2.3 Additional Equipment

EVA2100-A	Evaluation Kit (including one module A2100-A)
EVA2100-B	Evaluation Kit (including one module A2100-B)

Table 3: Additional equipment

A detailed description of the EVA2100-A/B Evaluation Kit can be found in the appropriate manual. The evaluation boards are always shipped with latest firmware loaded.

### 3 Quick Start

In order to allow an easy and quick start with the A2100-A module, this chapter provides a short overview on the important steps to be taken to receive NMEA messages with position information on a serial port (UART).

**NOTE 1:** The A2100-A needs an external pull-up resistor to be configured for UART operation. Please consider the pull-up resistor in your design or pull the GPIO up right after reset by other means.

**NOTE 2:** The ON\_OFF input of the A2100-A needs to be connected to output of a microprocessor. For a wake-up, including the initial one after power on, a LOW-HIGH transmission is mandatory.

#### 3.1 Minimum Configuration

The following picture shows the minimum configuration for NMEA or binary outputs received and commands sent via an RS232 interface based on the GPS module A2100-A using a passive antenna.

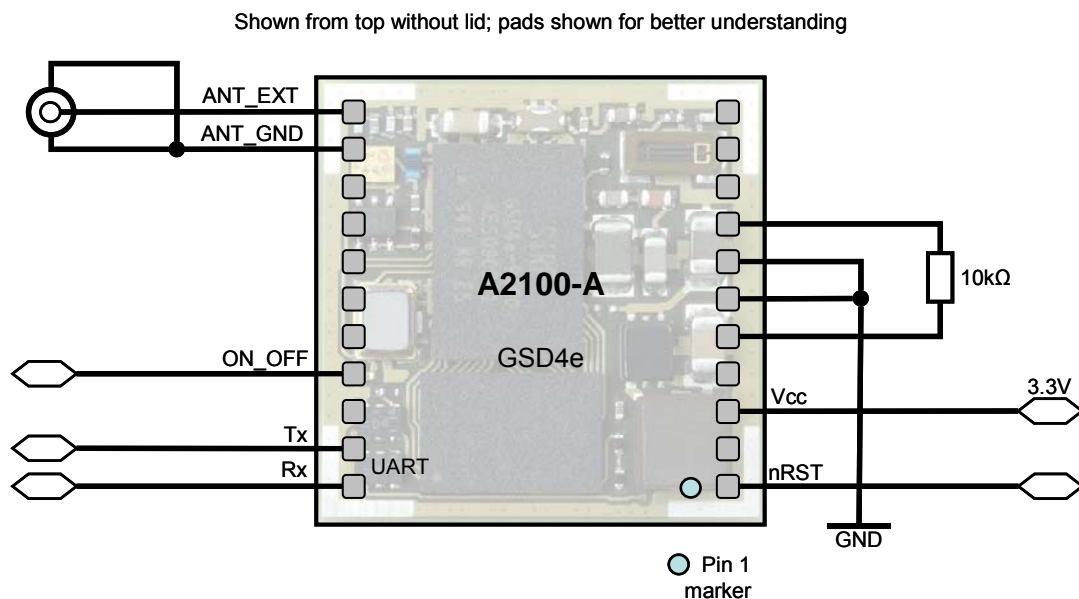

Figure 5: Minimum configuration A2100-A

**NOTE:** It is recommended to supply Vcc continuously! Use SiRFaware™ or other low power modes to reduce power consumption of the module while no position information is required.

**NOTE:** Care must be taken to implement an orderly shut-down sequence along with supplying power for a certain period of time after initiating the shut-down sequence. Abrupt removal or drop of power while the module is running has

risks ranging from minor impact on TTF to fatal corruption of flash memory code area!

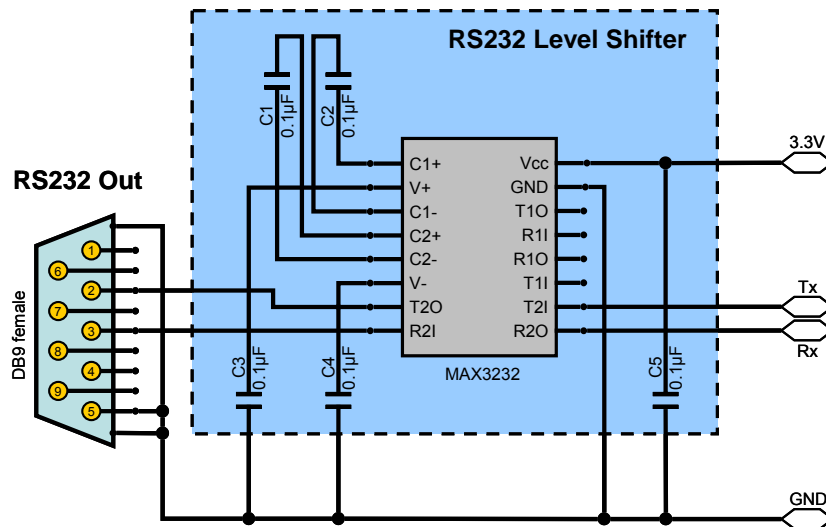

Figure 6: RS232 level shifter

Remarks:

- Place C1 to C5 (here: 0.1µF) close to MAX3232. For capacity values see datasheet of actual component used.
- Use 3.3V level shifter (MAX3232 or equivalent).
- External antenna input impedance is 50 Ω. Match as close as possible.

### 3.2 Antennas

Generally, the quality of the GPS antenna chosen (passive or active) is of paramount importance for the overall sensitivity of the GPS system. Losses through a bad antenna, long cables or tracks or a bad antenna position can't be compensated afterwards!

#### 3.2.1 Passive Antennas

The A2100-A supports passive antennas via an integrated LNA directly.

#### 3.2.2 Active Antennas

The A2100-A also supports active antennas directly, i.e. by offering an antenna voltage feed pin (VANT – pin 15). It is recommended to use an active antenna with a supply voltage of 3 to 5 VDC and a maximum current draw of 50 mA. The antenna should have a gain  $\geq 15$ dB but the total gain (antenna gain minus cable loss at the antenna input of the module) should not exceed 30 dB. The noise figure should be  $\leq 1.5$ dB.

### 3.3 Serial Port Settings

In UART operation (defined by the external pull-up resistor as outlined in Minimum Configuration) the default settings are:

- NMEA, 4800 baud, 8 data bits, no parity, 1 stop bit, no flow control

### 3.4 Improved TTFF

In order to improve the TTFF (Time To First Fix), it is recommended to keep Vcc supplied at all times. This will allow taking advantage of sophisticated low power mode features of the SiRFstarIV chip set. More details can be found in chapter “Application Notes”.

### 3.5 Firmware Updates(Flash-based module only)

Firmware upgrade function is only valid for Flash-based module. If later firmware changes are considered in a design it is necessary to connect the BOOTSEL pin of the A2100. BOOTSEL pin is used to control the mode of operation mentioned on table below:

BOOTSEL	Operating mode
Leave open	Normal operation
Pull up to 1.8V	Boot loader active for firmware upgrade

Table 4: BOOTSEL operating mode

A specific tool (SiRFFlash) is required for firmware upgrade upon request to Maestro. Recommended circuitry on application board was indicated below.

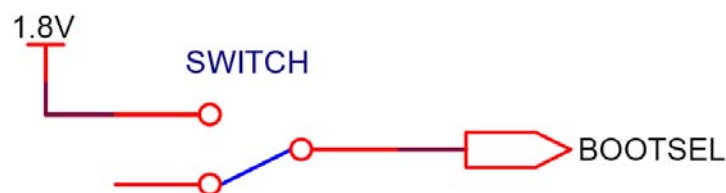
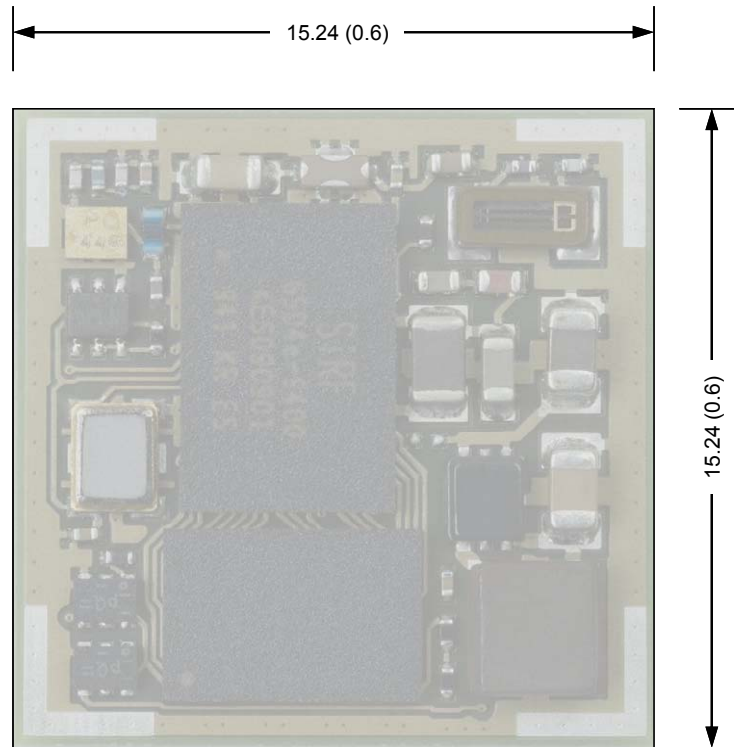

Figure 7: BOOTSEL application



## 4 Mechanical Outline

### 4.1 Details Component Side A2100-A / B



All dimensions in [mm, (inch)]

Figure 8: Mechanical outline component side A2100-A/B

## 4.2 Details Solder Side A2100-A/B

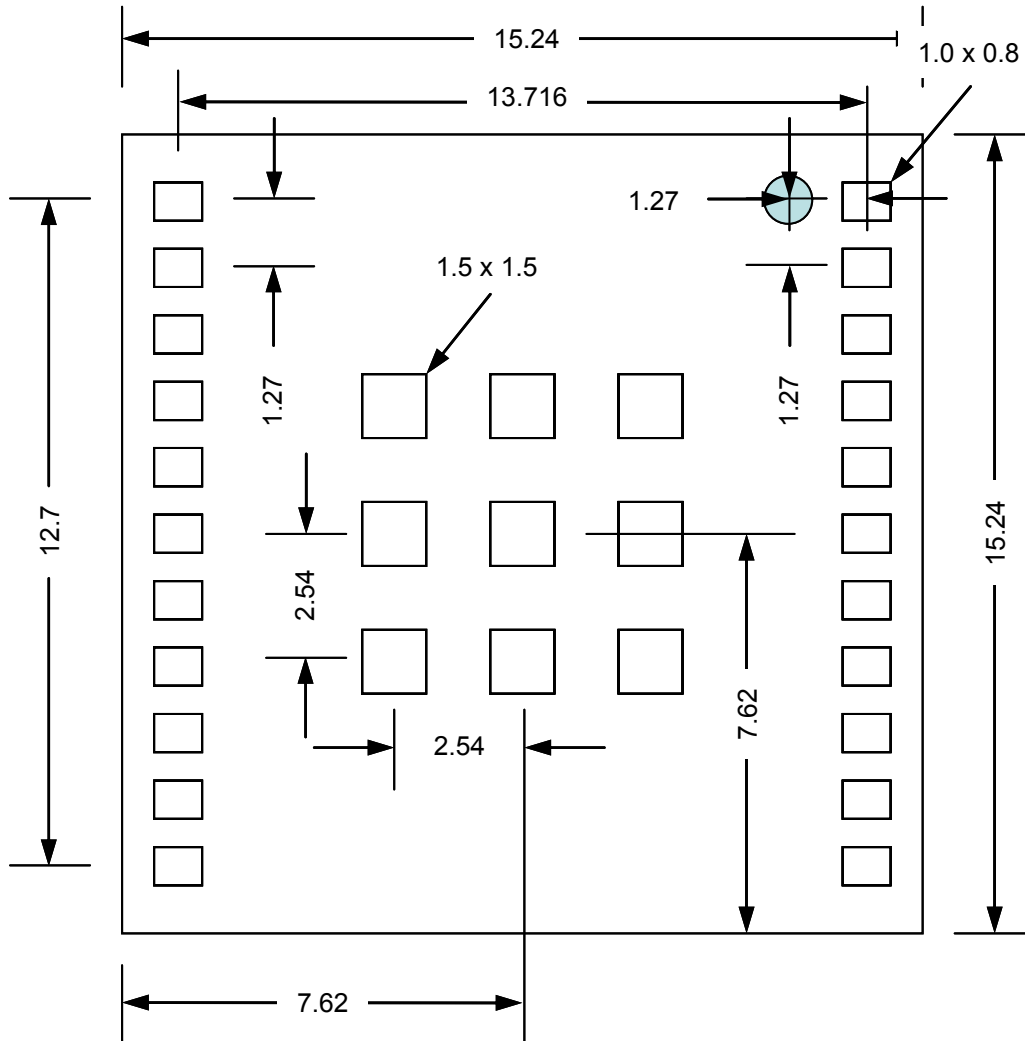

Solder pad size (outer pads): 1.0 x 0.8  
 Solder pad size (inner pads): 1.5 x 1.5  
 All dimensions in [mm]

Figure 9: Mechanical outline solder side A2100-A/B

## 5 Pin-out Information

### 5.1 Layout A2100-A

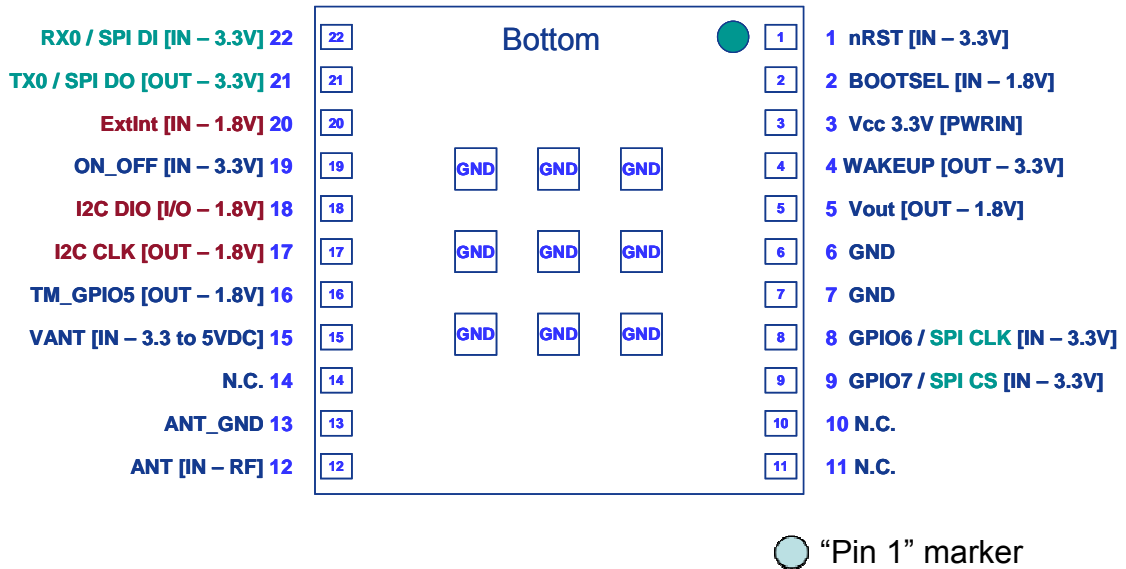

Figure 10: Pin-out information (bottom view) A2100-A

Green Description: Host interface pins

Red Description: MEMS interface pins (Firmware405 just supports KXSD9, Firmware410 supports KXTF9)

Blue Description: Other

Center Ground pins are for shock / vibration resistance purpose.

## 5.2 Description A2100-A Signals

Pin	Symbol	Function	Description
1	nRST	Input	Reset input, active low
2	BOOTSEL	Input	Special boot mode – leave open for normal operation; HIGH – boot loader active; HIGH level: 1.8V
3	Vcc	Power Supply	3.0 – 3.6 VDC (power supply)
4	WAKEUP	Output	Status of digital section, Push-Pull output Low = OFF, KA (Keep Alive)-only, Hibernate, or Standby mode High = ON, operational mode Identical logic to RFPWUP of A1084 on same pin!
5	Vout	Voltage output	Permanent 1.8V voltage output for up to 20mA current max.
6	GND	Power Supply	Ground (power supply)
7	GND	Power Supply	Ground (power supply)
8	GPIO6 CTS SPI CLK	Input	Configuration pin to run in UART mode (10k pull-up to 1.8V, e.g. to Vout, pin 5), leave open for SPI mode. SPI clock pin when module works in SPI mode
9	GPIO7 RTS SPI CS	Input	Unused configuration pin – reserved for future use, leave open SPI chip select pin when module works in SPI mode
10	N.C.	None	Leave open
11	N.C.	None	Leave open
12	ANT	Antenna Input	Antenna signal / Z=50 Ohm (antenna input) – must not exceed 30dB gain including cable loss
13	ANT_GND	RF GND	Antenna Ground
14	N.C.	None	Leave open
15	VANT	Antenna Supply Voltage Input	Power supply input for external active antenna – provide according voltage (up to 5.0 VDC) – switched internally
16	TM_GPIO5	Output	Time Mark – 1PPS signal
17	I2C CLK	Input	I2C clock input for MEMS interface
18	I2C DIO	Input/Output	I2C I/O for MEMS interface
19	ON_OFF	Input	<b>Connect to push-pull output! This is mandatory!</b> - Set to LOW by default - Toggle to HIGH and back to LOW - for first start-up after power on - to request a fix in SiRFaware™ or PTF mode - to go into or wake up out of hibernate mode
20	ExtInt	Input	Interrupt input for MEMS interface (If ExtInt is not going to be used, it is recommended that this pin be tied directly to ground. Otherwise, a 100K pull-down resistor to ground should be connected to the ExtInt pin.)
21	TX0 SPI DO	Output	Serial output 0, NMEA out if configured for UART SPI data out pin when module works in SPI mode
22	RX0 SPI DI	Input	Serial input 0, NMEA in if configured for UART SPI data in pin when module works in SPI mode

Table 5: Pin description A2100-A

### 5.3 Layout A2100-B

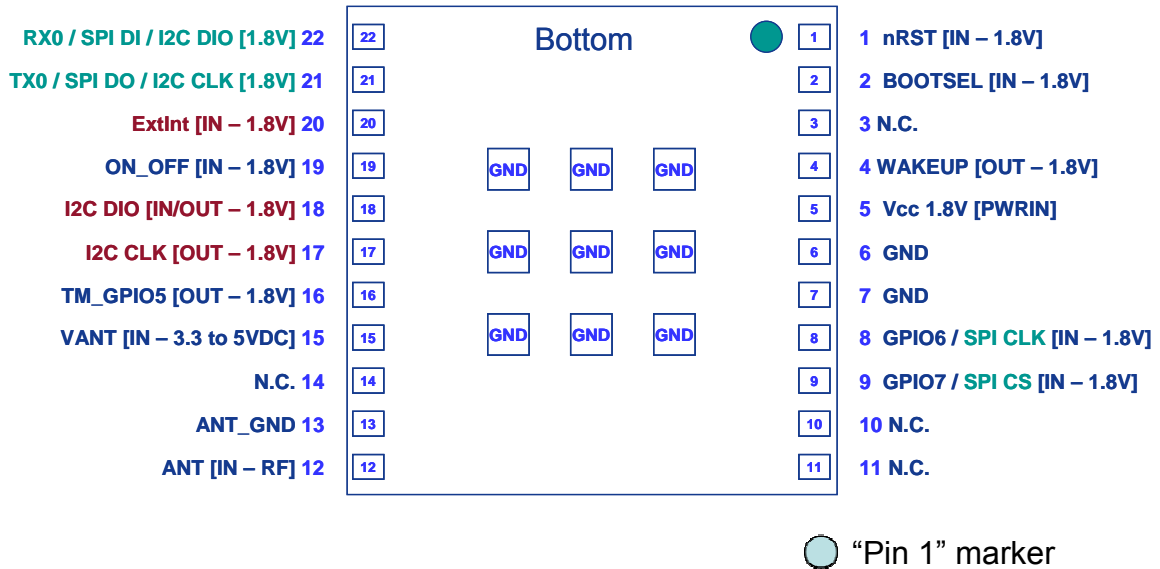

Figure 11: Pin-out information (bottom view) A2100-B

Green Description: Host interface pins

Red Description: MEMS interface pins (Firmware405 just supports KXSD9, Firmware410 supports KXTF9)

Blue Description: Other

Center Ground pins are for shock / vibration resistance purpose.

## 5.4 Description A2100-B Signals

Pin	Symbol	Function	Description
1	nRST	Input	Reset input, active low
2	BOOTSEL	Input	Special boot mode – leave open for normal operation; HIGH – boot loader active; HIGH level: <b>1.8V</b>
3	N.C.	None	Leave open
4	WAKEUP	Output	Status of digital section, Push-Pull output Low = OFF, KA (Keep Alive)-only, Hibernate, or Standby mode High = ON, operational mode Identical logic to RFPWUP of A1084 on same pin!
5	Vcc	Power Supply	1.7 – 1.9 VDC (power supply)
6	GND	Power Supply	Ground (power supply)
7	GND	Power Supply	Ground (power supply)
8	GPIO6 CTS SPI CLK	Input	Configuration pin to run in UART mode (10k pull-up to 1.8V, e.g. to Vcc, pin 5); leave open for SPI & host port I2C modes SPI clock pin when module works in SPI mode
9	GPIO7 RTS SPI CS	Input	Configuration pin for communication mode. 10K to GND for host port I2C mode; leave open for SPI & UART modes SPI chip select pin when module works in SPI mode
10	N.C.	None	Leave open
11	N.C.	None	Leave open
12	ANT	Antenna Input	Antenna signal / Z=50 Ohm (antenna input) – must not exceed 30dB gain including cable loss
13	ANT_GND	RF GND	Antenna Ground
14	N.C.	None	Leave open
15	VANT	Antenna Supply Voltage Input	Power supply input for external active antenna – provide according voltage (up to 5.0 VDC) – switched internally
16	TM_GPIO5	Output	Time Mark – 1PPS signal
17	I2C CLK	Input	I2C clock input for MEMS interface
18	I2C DIO	Input/Output	I2C I/O for MEMS interface
19	ON_OFF	Input	<b>Connect to push-pull output! This is mandatory!</b> - Set to LOW by default - Toggle to HIGH and back to LOW - for first start-up after power on - to request a fix in SiRFaware™ or PTF mode - to go into or to wake up out of hibernate mode
20	ExtInt	Input	Interrupt input for MEMS interface ( If ExtInt is not going to be used, it is recommended that this pin be tied directly to ground. Otherwise, a 100K pull-down resistor to ground should be connected to the ExtInt pin.)
21	TX0 SPI DO (Host port I2C_CLK)	Output	Serial output 0, NMEA out if configured for UART SPI data out pin when module works in SPI mode Host port I2C clock pin when module works in host port I2C mode
22	RX0 SPI DI	Input	Serial input 0, NMEA in if configured for UART SPI data in pin when module works in SPI mode

	(Host port I2C_DIO)		Host port I2C data I/O pin when module works in hist port I2C mode.
--	---------------------	--	---

Table 6: Pin description A2100-B

## 6 Electrical Characteristics

### 6.1 Operating Conditions

Pin	Description	Min	Typical	Max
3	V <sub>cc</sub>	3.0V	3.3V	3.6V
	Full power Mode (Searching) Peak Current <sup>(1)</sup>		45mA	
	Full power mode (Searching) Average Current <sup>(2)</sup>		33.6mA	
	Full power mode (Tracking) Average Current <sup>(3)</sup>		18.5mA	
	TricklePower Mode <sup>(4)</sup>		4.6mA	
	Push-to-Fix Mode		56.5uA	
	Micro Power Mode (SiRFaware™)		40uA	
	Hibernate Status		23.5uA	

Table 7: A2100-A electrical characteristics

Pin	Description	Min	Typical	Max
5	V <sub>cc</sub>	1.7V	1.8V	1.9V
	Full power Mode (Searching) Peak Current <sup>(1)</sup>		62mA	
	Full power mode (Searching) Average Current <sup>(2)</sup>		56.5mA	
	Full power mode (Tracking) Average Current <sup>(3)</sup>		39.7mA	
	TricklePower Mode <sup>(4)</sup>		9.2mA	
	Push-to-Fix Mode		291uA	
	Micro Power Mode (SiRFaware™)		31uA	
	Hibernate Status		22uA	

Table 8: A2100-B electrical characteristics

- (1) Peak searching current is characterized by millisecond bursts above average searching current
- (2) Average searching current is typically only the first two seconds of TTFF
- (3) Tracking current typically includes tracking and the post searching portion of TTFF
- (4) When TP (TricklePower™) Mode is enabled, the receiver maximises the navigation performance. Under normal tracking conditions, the TP Mode performs normal TP Mode cycles, but in harsh tracking environments, the receiver automatically switches to FP (Full-power) Mode to improve navigation performance. When the satellites are sorted according to their signal strength, the fourth satellite determines if the transition occurs or not. Currently, the threshold is 30dB-Hz to enter TP Mode cycling and 26dB-Hz to return to FP Mode cycles. please refer to "SiRFstarIV GSD4eGSD4t Power Management Modes (CS-212074-AN-2).pdf".

\*Remark: Test data based on firmware version GSD4e\_4.1.0-P1\_FLASH



## 6.2 Absolute Maximum Ratings

Symbol	Parameter	Min	Max	Unit
Vcc	A2100-A Power supply	-0.3	+4.6	V
Vcc	A2100-B Power supply	-0.3	+2.2	V
Vin	Voltage to I/O pins	-0.3	+3.6	V
Iov	Input current on I/O pins	-10	10	mA
Itdv	Absolute sum of all input currents during overload condition		200	mA
Tst	Storage temperature	-40	85	°C
Vant	Antenna supply voltage	0	5.5	V
Iant	Antenna supply current	0	50	mA

Table 9: Absolute maximum ratings

Stresses beyond those listed under “Absolute Maximum Ratings” may cause permanent damage to the device. This is a stress rating only. Functional operation of the device at these or any other conditions beyond those indicated in the operational sections of this specification is not implied. Exposure to absolute maximum rating conditions for extended periods may affect device reliability.

### 6.3 DC Electrical Characteristics

Symbol	Parameter	Min	Max	Unit
TX0, WAKEUP	Voh @ 4mA	2.6	Vcc	V
	Vol @ 4mA		0.45	V
RX0	Vih	2.0	Vcc	V
	Vil		0.8	V
nRST	for safe reset		0.2	V
ON_OFF	Vih	1.35	Vcc	V
	Vil	-0.3	0.45	V
BOOTSEL	Vih	1.35	2.2	V

Table 10: DC electrical characteristic A2100-A

Symbol	Parameter	Min	Max	Unit
TX0, WAKEUP	Voh @ 4mA	1.4	Vcc	V
	Vol @ 4mA		0.4	V
RX0	Vih	1.1	Vcc	V
	Vil		0.8	V
nRST	for safe reset		0.2	V
ON_OFF	Vih	1.35	Vcc	V
	Vil	-0.3	0.45	V
BOOTSEL	Vih	1.35	2.2	V

Table 11: DC electrical characteristic A2100-B

## 7 Mounting

This chapter describes the suggested mounting process for the A2100-A receiver modules. In a RoHS compliant product with a RoHS compliant process it is recommended to use chemical tin as the counter-part to the module's pins. This will guarantee highest resistance against shocks.

### 7.1 Proposed Footprint for Soldering

Following soldering footprint parameters are recommended:

- Copper and solder paste footprint are identical
- Pad-shape / -size, inner pads: 1.5 mm x 1.5 mm
- Pad-shape / -size, outer pads: 1.762 mm x 0.8 mm
- Stencil thickness of 120 – 150  $\mu\text{m}$

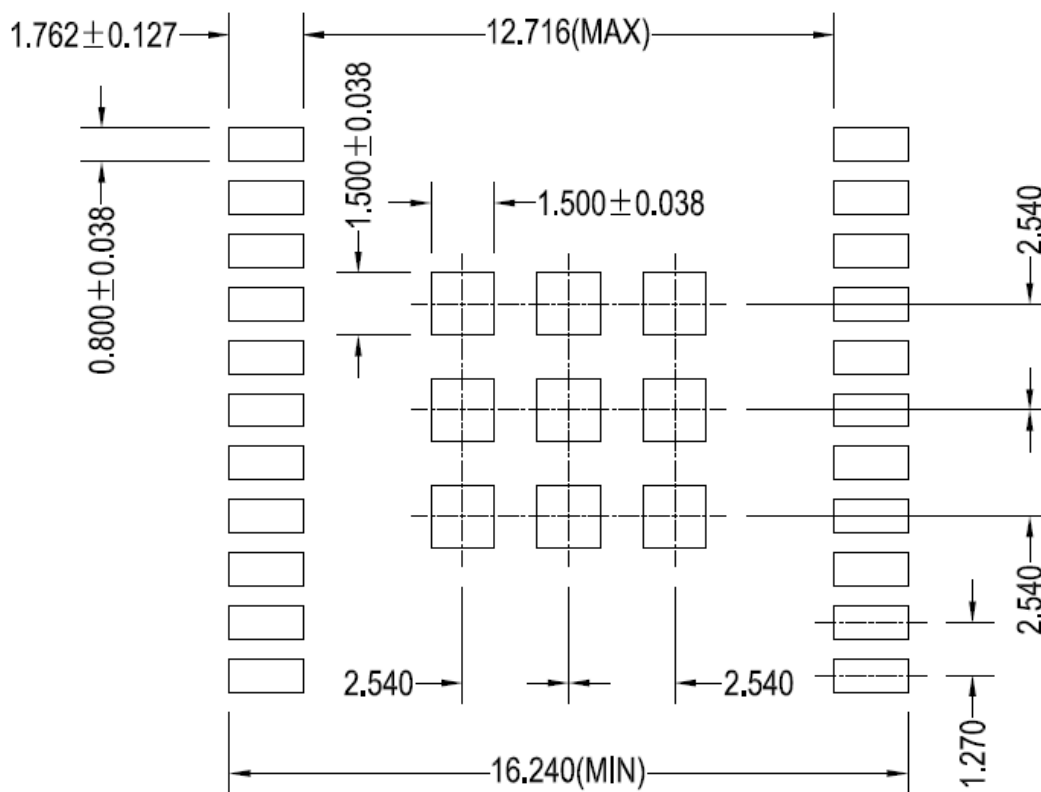

Figure 12: Recommended Solder PAD Layout

## 7.2 Recommended Profile for Reflow Soldering

Typical values for reflow soldering of the module in convection or IR/convection ovens are as follows (according to IPC/JEDEC J-STD-020D):

Parameter	Value
Peak temperature (RoHS compliant process)	245°C
Average ramp up rate to peak (217°C to Peak)	3°C / second max.
Preheat temperature	min=150°C; max=200°C
Ramp up time from min. to max. preheat temperature	60 ... 120 seconds
Temperature maintained above 217°C	60 ... 150 seconds
Time within 5°C of actual peak temperature	30 seconds
Ramp down rate	6°C / second max.
Time 25°C to peak temperature	8 minutes max.

Table 12: Reflow soldering profile A2100-A/B

The solder pads hold solder of a thickness of about 150 µm for improved solder process results.

As results of soldering may vary among different soldering systems and types of solder and depend on additional factors like density and types of components on board, the values above should be considered as a starting point for further optimization.

## 8 Use of GPS Antennas

### 8.1 Connecting a GPS antenna to the GPS receiver

The ANT pin is used to connect a GPS antenna to the receiver. The design of the antenna connection has to be done strictly according to RF design rules. A  $50\ \Omega$  PCB strip line is required. The following drawings shall explain the guidelines. A major rule is to keep the strip line as short as possible. Additionally, antenna ground (ANT\_GND) should be routed to the ground plane of the PCB (the ground plane is on a lower PCB layer) by vias as demonstrated in the drawing.

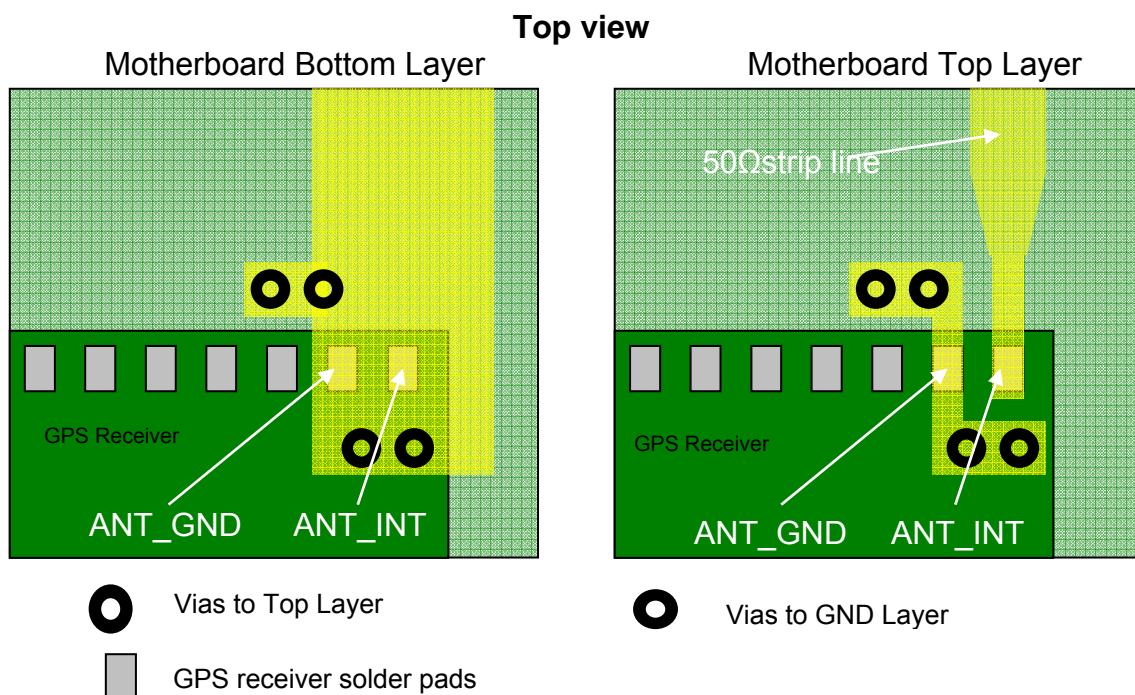

Figure 13: Antenna connector strip line A2100-A/B

In order to achieve the impedance of  $50\ \Omega$ , the width of the strip line needs to be calculated. It depends on the thickness or height of the PCB layer (both parameters are shown in following drawing). For the calculation, it is assumed that the PCB material is FR4.

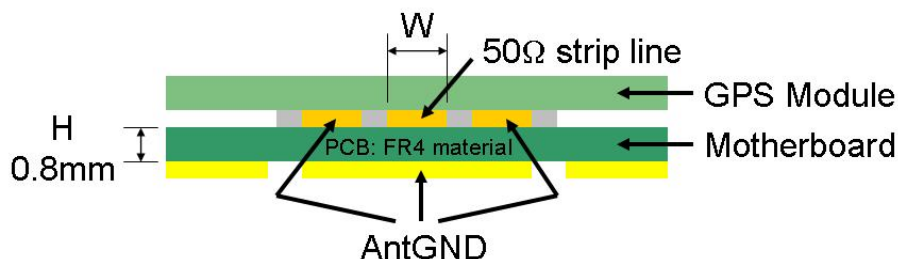

Figure 14: Strip line parameters A2100-A/B

In this case, the width should be about 1.8 times the height of the PCB:

$$W = 1.8 \times H$$

In the example, one would get a width of  $W = 1.8 \times 0.8 \text{ mm} = 1.44 \text{ mm}$ .

## 8.2 Antenna Connections

### 8.2.1 Passive Antennas

A passive antenna connected to ANT input (pin 12) should be placed as close as possible to the GPS receiver. The signal power lost by the antenna cable or lost by the strip line on the PCB can not be recovered by the LNA (Low Noise Amplifier) integrated in the GPS receiver.

A suitable Ground-Plane design should be considered depending on the antenna type connected to ANT input (pin 12).

### 8.2.2 Active Antennas

General GPS active antenna specification:

Limitations:

- Supply voltage (voltage fed into VANT pin) 5V (max.)
- Supply current 50mA (max.)

Recommendations:

- Gain  $\geq 15\text{dB}$  (should not exceed 30 dB including cable loss)
- Noise figure  $\leq 1.5\text{dB}$

The recommendations apply to the majority of active antennas that can be found in the market. Anyhow, the quality of the GPS antenna chosen is of paramount importance for the overall sensitivity of the GPS system.

The system design needs to reflect the supply voltage of the antenna. If the supply voltage is equal to  $V_{cc}$ ,  $V_{cc}$  can be connected to VANT. If the antenna requires a different supply voltage, the antenna bias can be provided through the VANT pin.

VANT is switched by the module, so current is only drawn when required.

## 9 Quality and Reliability

### 9.1 Environmental Conditions

Operating temperature	-40 ... +85°C
Operating humidity	Max. 85% r. H., non-condensing, at 85°C
MSL JEDEC (Moisture Sensitivity Level)	3
Storage	6 months in original package.

Table 13: Environmental conditions

### 9.2 Product Qualification

Prior to product qualification the GPS receiver is preconditioned according to EIA/JEDEC standard JESD22-A113-B / Level 3.

Basic qualification tests:

- MSL Classification according to J-STD-020C (MSL3 @ 245°C)
- MSL Rework Compatibility according to J-STD-020C
- Temperature Cycling –40°C ... +85°C
- Temperature Humidity Bias 70°C / 85% RH
- Low / High Temperature Operating –40°C / +85°C
- High Temperature Operating Life +85°C
- Vibration Variable Frequency
- Mechanical Shock

Please contact Maestro for detailed information.

### 9.3 Production Test

Each module is electrically tested prior to packing and shipping to ensure state of the art GPS receiver performance and accuracy.



## 10 Applications and Hints

### 10.1 Initial Module Start

After initially applying power to the module, it is necessary to start the internal firmware by toggling the ON\_OFF pin. Toggling is done by pulling the signal to HIGH for about 200ms. This first toggling can be done after a LOW – HIGH transmission was detected at the WAKEUP pin or by simply waiting for 1s after power-up. In case of configuration for UART mode, messages should be transmitted afterwards. If no messages should appear, a new toggling should be applied.

### 10.2 Proper Shutdown

The A2100-A/B modules require an orderly shutdown process to properly stop internal operation and complete any writes of critical data to BBRAM or Flash memory data area. Abrupt removal or drop of main power while the system is running has risks ranging from minor impact on TTFF to fatal, permanent corruption of flash memory code area on the module.

A controlled and orderly shutdown while the A2100-A/B is running in full power mode can be initiated by

- A 200ms pulse on the ON\_OFF pin,
- According messages either in NMEA or OSP mode.

The shutdown is completed after maximum 1s. Therefore the module should be supplied with voltage for that time after the shutdown sequence was initiated.

### 10.3 SiRFaware™ Support

SiRFaware™ is a low-power operating mode that seeks to maintain low uncertainty in position, time, and frequency, and to maintain valid current Ephemeris using either data collected from satellites in view or Extended Ephemeris methods.

The SiRFaware™ mode is entered using the One Socket Protocol, an extension of the SiRF Binary Protocol. Please refer to the appropriate manual. In order to request a fix and to exit SiRFaware™ it is necessary to toggle the ON\_OFF pin. Toggling is done by pulling the signal to HIGH for about 200ms.

### 10.4 Push-to-Fix Mode

Push-to-Fix mode is designed for the application that requires infrequent position reporting. The receiver generally stays in a low-power mode, up to 2 hours, but wakes up periodically to refresh position, time, ephemeris data and RTC calibration.

The push-to-fix mode is initialized and entered using the SiRF Binary Protocol. Please refer to the appropriate manual, paying particular attention to the paragraph titled “Set TricklePower Parameters”. In order to request a fix outside the specified

duty cycles, it is necessary to toggle the ON\_OFF pin. Toggling is done by pulling the signal to HIGH for about 200ms.

### **10.5 Hibernate Mode**

In order to enter Hibernate Mode it is necessary to send a shutdown command or to toggle to ON\_OFF pin by pulling the signal to HIGH for about 200ms. Starting with firmware version 4.0.1 the according command is supported in NMEA and SiRF Binary mode. After a short delay the module will switch into hibernate mode. The RTC will keep on running and SRAM is backed with the typical current of 20  $\mu$ A drawn from Vcc. To wake the module up again, toggling the ON\_OFF pin is necessary (200ms pulse width).

### **10.6 Extended Ephemeris**

The receiver is capable of supporting two versions of using Extended Ephemeris (EE) data. The first one is the version, where the EE data are calculated on a server, are transmitted to device incorporating the receiver, and are then loaded into the receiver. These data can be valid for up to seven days.

The second version is the internal extrapolation of available “natural” Ephemeris data. This is done automatically and no external support is required. The internally calculated EE data are valid for up to 3 days.

The receiver firmware will define which set of EE data to use or will neglect those in case “natural” data are available. Both versions of EE data will help to further lower power consumption in SiRFaware™ mode.

## 10.7 Antenna Status Adaptation

This chapter shall give assistance in designing a circuit for detecting if an active antenna is connected to the module. The information about the antenna status can be derived from the ANTSTAT signal generated by this circuit. The examples use values for components that roughly result in the following ANTSTAT output:

- Logic low when:  $I_{ant} < 9\text{mA}$
- Logic high when:  $9\text{mA} > I_{ant} < 16\text{mA}$
- Logic low when:  $I_{ant} > 16\text{mA}$

### 10.7.1 Antenna Sensor

The following circuit is a proposal on how you can feed an antenna with 3.3V and provide an output for the ANTSTAT pin. The value of the components may need an adaptation in the final application. For example, the input current of the chosen comparator goes into that equation. The thresholds defined in this circuit are quite close to the ones described above. Their value is determined by resistors R4, R5, and R3.

We strongly recommend simulating and testing the GPS receiver integrated in your product design before implementing the finalized product in the appropriate market application.

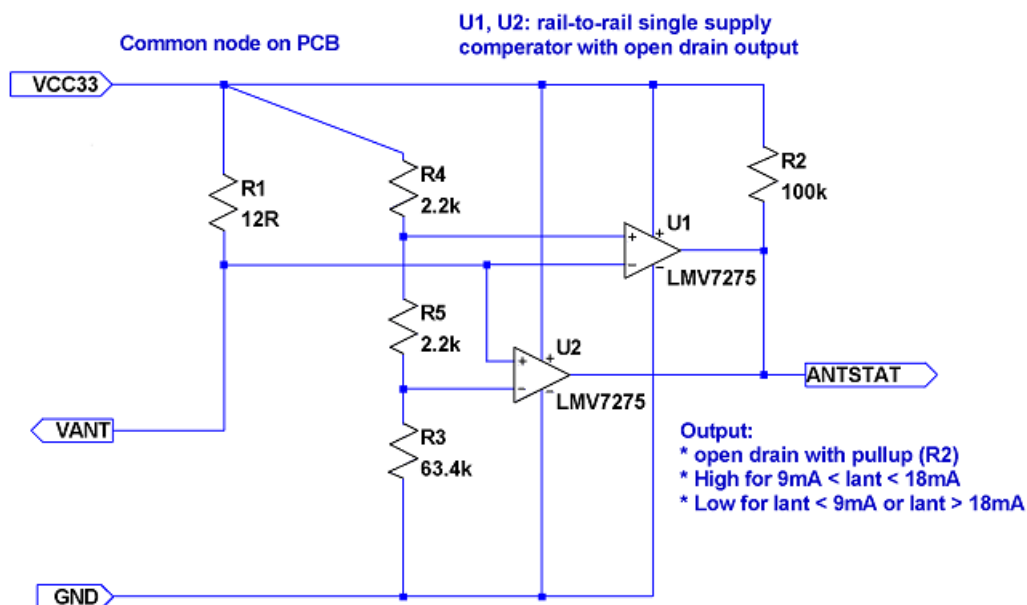

Figure 15: Application note: Antenna sensor adaptation

### 10.7.2 Antenna Sensor with Current Limiter

This proposal is similar to the first one, but includes a current limiter. Comments and notes as above apply.

We strongly recommend simulating and testing the GPS receiver integrated in your product design before implementing the finalized product in the appropriate market application. In any case it is the responsibility of the designer to test and verify the implementation.

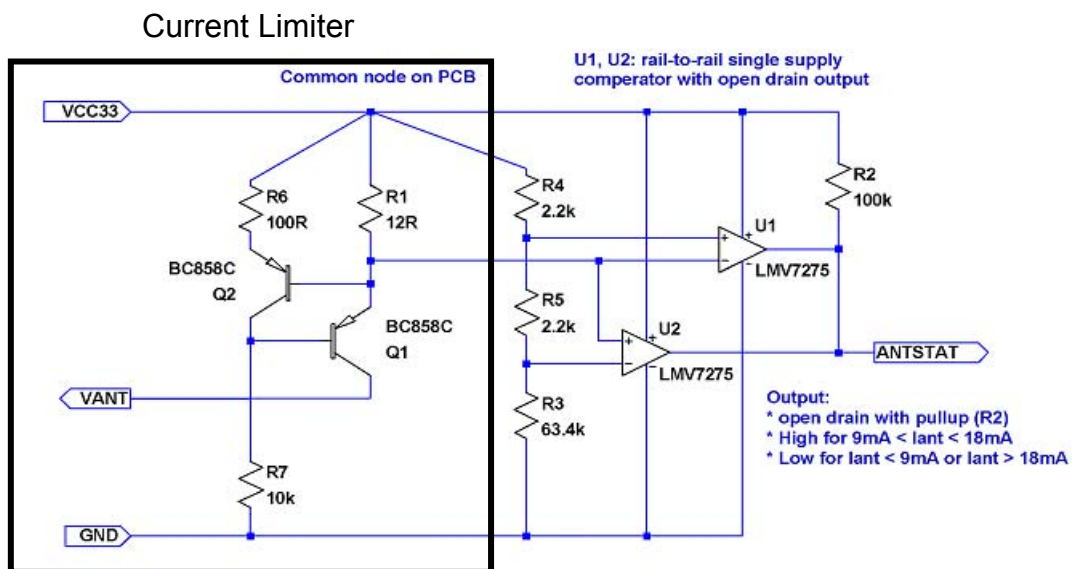

Figure 16: Application note: Antenna sensor adaptation with current limiter

## 10.8 VANT Pin

The VANT pin is an input pin.

The supply voltage for an active GPS antenna on the ANT input has to be fed into the Vant pin. The easiest way to do that is to connect Vcc to VANT. The maximum current is 50 mA.

**Note:** Shortcut between ANT and GND may damage the A2100-A GPS receiver module. This should be avoided by using an antenna current limiter.

The circuit (chapter “10.7.2 Antenna Sensor with Current Limiter”) works for Vcc from 3V to 5V. The antenna current will be limited to 50 mA approximately.

If other transistors are used, other resistor values may be necessary as well. We strongly recommend simulating and testing your realized version before using it.

## 10.9 TM\_GPIO5 pin (1 pulse per second pin)

The 1PPS pin is an output pin.

In addition to precise positioning, GPS also allows for accurate timing due to the synchronized atomic clocks in the GPS satellites. While the current date and time is transmitted in NMEA sentences (UTC), an exact and accurate timing signal is provided via the 1PPS pin of the A2100 GPS receiver.

Under good signal conditions the 1PPS signal comes between 620ns and 710ns after the full GPS system second which is accurately (around 10ns) synchronized to UTC. Therefore the 1 second clock can be derived and maintained within around 90ns under good signal conditions.

Note:

The 1PPS clock accuracy directly depends on the position accuracy!

The GPS signals travel at the speed of light, therefore a position inaccuracy directly translates into 1PPS inaccuracies.

10m position deviation  $\approx$  33ns 1PPS deviation (typically)

100m position deviation  $\approx$  333ns 1PPS deviation (typically)

The NMEA messages containing absolute timing information (UTC time) are provided around 300ms after the 1PPS signal typically. This may change with the GPS receiver setup.

The 1PPS signal is provided on a “as is” basis with no accuracy specification. It's NOT recommended to use 1PPS signal for accurate timing application.

The given values are based on a 10 satellite, static GPS simulator scenario.

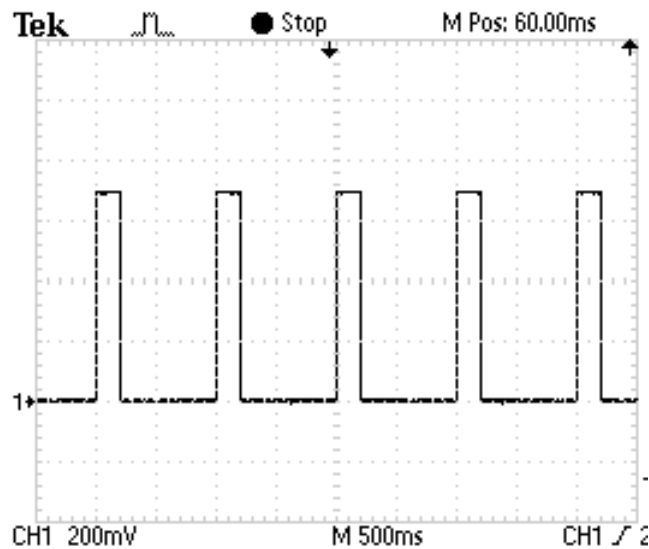

Figure 17: 1PPS waveform (reference)

### 10.10 5 Hz Navigation Update Rate

User can select 1Hz or 5Hz output rate of navigation computation and message, it supports rapid change of direction and improves accuracy on sport-related applications. 1Hz is the default Navigation Update Rate, If the user want to change to 5Hz Navigation Update Rate, Please refer to command below:

Enable 5Hz Navigation Update Rate command

- NMEA command MID103 (\$PSRF103,00,6,00,0\*23)
- OSP command MID136 (A0 A2 00 0E 88 00 00 04 04 00 00 00 00 00 00 0F 02 00 A1 B0 B3 )

Disable 5Hz and return to 1Hz Navigation Update Rate, command:

- NMEA command MID103 (\$PSRF103,00,7,00,0\*22)
- OSP command MID136 (A0 A2 00 0E 88 00 00 04 00 00 00 00 00 00 00 0F 02 00 9D B0 B3)

## 11 Evaluation Kit EVA2100-A/B

For demonstration and easy evaluation of GPS performance Maestro offers an evaluation kit (including one GPS A2100-A/B module). It contains a USB interface with according drivers to connect easily to a PC. The USB interface is an extension of the serial port 0, therefore sending NMEA sentences or binary information and accepting commands. At the same time it provides power to the module. Accompanied by both an active and passive antenna it offers a ready-to-go set.

For the development of new software and applications the Evaluation Kit also provides NMEA and binary messages on CMOS level via a terminal plug.

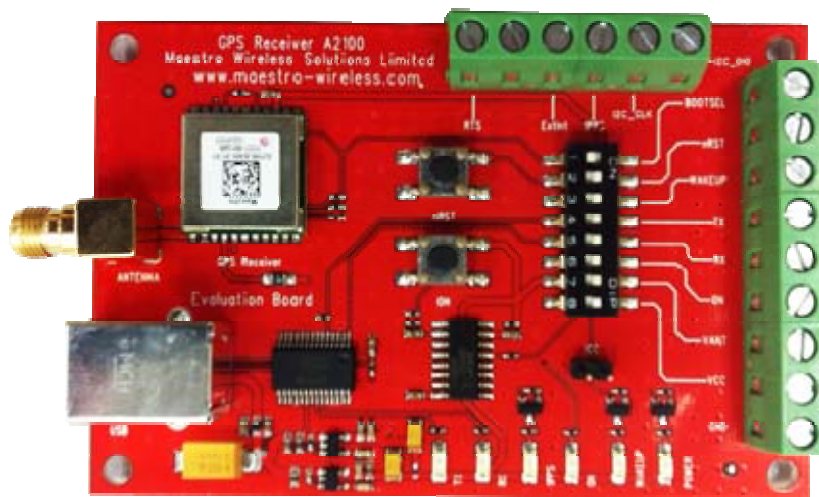

Figure 18: Evaluation kit EVA2100-A/B

For further information please contact Maestro.

## 12 Related Information

### 12.1 Contact

This manual was created with due diligence. We hope that it will be helpful to the user to get the most out of the GPS module.

Inputs regarding errors or mistaken verbalizations and comments or proposals to Maestro, Hongkong, for further improvements are highly appreciated.

#### **Maestro Wireless Solutions Limited**

Add:Unit 3603-09,36/F.,118 Connaught Road West,HK

Main Line: (852) 28690688

Fax: (852)25254701

support-gps@maestro-wireless.com

www.maestro-wireless.com

### 12.2 Related Documents

- GPS Firmware GSD4e (Maestro)
- GPS Evaluation Kit EVA2100-A/B (Maestro)
- GSD4e NMEA Manual (SiRF)
- GSD4e OSP Manual (SiRF)
- Kionix: KXSD9 SERIES  
<http://www.kionix.com/accelerometers/accelerometer-KXSD9.html>
- Kionix: KXTF9 SERIES  
<http://www.kionix.com/accelerometers/accelerometer-KXTF9.html>

### 12.3 Related Tools

- GPS Cockpit (Maestro)
- SiRFLive (SiRF)
- SiRFflash (SiRF)



## 13 List of Figures

Figure 1: A2100-A label .....	8
Figure 2: A2100-A/B tape specifications (1).....	10
Figure 3: A2100-A/B tape specifications (2).....	11
Figure 4: A2100-A/B tape specifications (3).....	11
Figure 5: Minimum configuration A2100-A .....	14
Figure 6: RS232 level shifter .....	15
Figure 7: BOOTSEL application .....	16
Figure 8: Mechanical outline component side A2100-A/B.....	17
Figure 9: Mechanical outline solder side A2100-A/B.....	18
Figure 10: Pin-out information (bottom view) A2100-A.....	19
Figure 11: Pin-out information (bottom view) A2100-B.....	21
Figure 12: Recommended Solder PAD Layout .....	27
Figure 13: Antenna connector strip line A2100-A/B .....	29
Figure 14: Strip line parameters A2100-A/B.....	29
Figure 15: Application note: Antenna sensor adaptation.....	35
Figure 16: Application note: Antenna sensor adaptation with current limiter.....	36
Figure 17: 1PPS waveform (reference).....	38
Figure 18: Evaluation kit EVA2100-A/B.....	39

## 14 List of Tables

Table 1: A2100-A/B GPS characteristics .....	9
Table 2: A2100-A/B dimensions and weight .....	9
Table 3: Additional equipment.....	13
Table 4: BOOTSEL operating mode .....	16
Table 5: Pin description A2100-A.....	20
Table 6: Pin description A2100-B.....	23
Table 7: A2100-A electrical characteristics .....	24
Table 8: A2100-B electrical characteristics .....	24
Table 9: Absolute maximum ratings.....	25
Table 10: DC electrical characteristic A2100-A.....	26
Table 11: DC electrical characteristic A2100-B .....	26
Table 12: Reflow soldering profile A2100-A/B.....	28
Table 13: Environmental conditions .....	32