

Global Connector Technology Ltd. - USB3130: μ USB Receptacle, Type B, Through Hole, Vertical, With Through Hole Shell Stakes

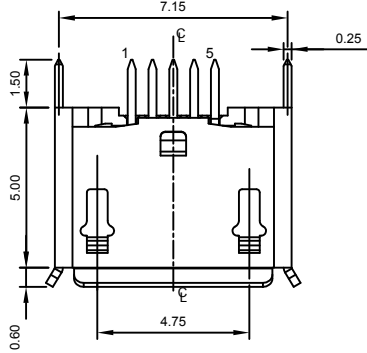

Designed to comply with physical, electrical and environmental requirements of Micro USB Standard (USB2.0), A/B types support USB On-The-GO (OTG) interface.

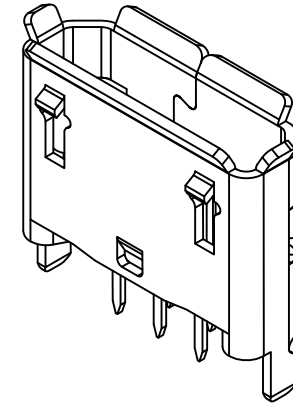
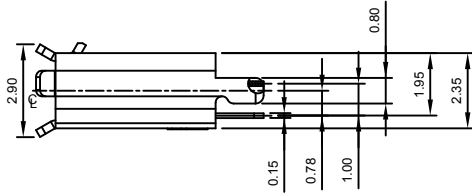
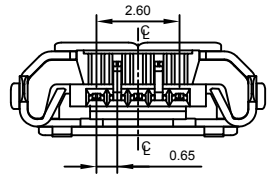
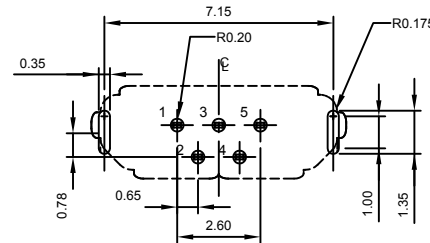
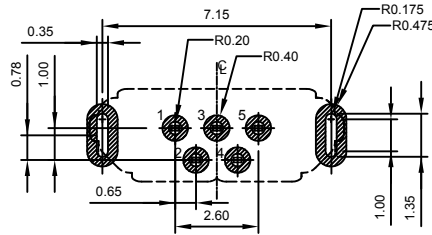
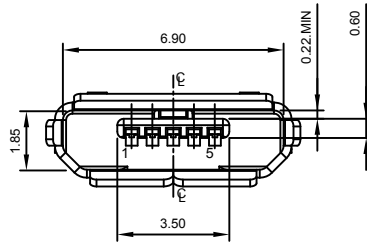

PASTE-IN-HOLE RECOMMENDED P.C.B LAYOUT

WAVE SOLDER RECOMMENDED P.C.B LAYOUT

GENERAL TOLERANCE: ± 0.05
AS VIEWED FROM COMPONENT SIDE

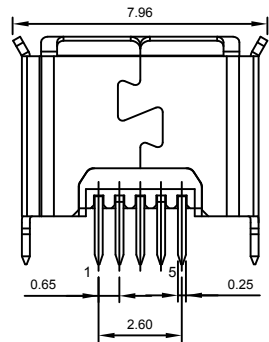

Ordering Grid

USB3130 - 30 - A REQUEST SAMPLES AND QUOTATION

Contact Plating
30 = 30u" Gold

Packing Options
A = Tape & Reel
(1.5K per Reel)

Specifications 规格:

Materials 材料:

Plastic Housing 塑胶外壳: LCP, UL94V-0, Black, LCP, UL94V-0 黑色.
Contact Terminal 接触端子: Copper Alloy 铜合金.
Metallic Shell 金属外壳: Stainless Steel 不锈钢 SUS304 T=0.2mm.

Finish 表面处理:

Underplating 底层电镀: Nickel 镍 100u" min.
Plating 电镀:
Contact Area 接触面积: 30u" Gold plating, 30u" 镀金
Solder Tails 焊接末端: Gold Flash 闪金
Metallic Shell 金属外壳: Matte Tin 雾锡 80u" min.

Electrical 电气规格:

Voltage Rating 电压额定值: 30V
Current Rating 电流额定值: Signal (Pins 2,3,4)信号: 1.0 A.
Power (Pins 1,5)电源: 1.8A.
Operating Temperature 工作温度: -55°C to +85°C.
Contact Resistance 接触电阻值: 30m Ω Max.
Insulating Resistance 绝缘电阻值: 1000M Ω Min.
Dielectric Withstand Voltage 耐电压: 100V AC/Minute

Mechanical 机械性规格:

Mating Force 插入力: 35N Max.
Unmating Force 拔出力: Initial 10N Min., 初始10N,
Final 8N Min., 最后8N
Durability 耐久性: 10,000 Cycles 次插拔

By	ASE	CM
DETAIL	DRAWING RELEASE	PCN:- USB3130-001
REV	A	B
DATE	21/10/11	23/01/12



Tolerances (Except as noted)	Part Number:-	Date:-
Dimensions in mm	USB3130	21 OCT 11
X.X \pm 0.35	Description:-	
X.XX \pm 0.25	μ USB RECEPTACLE, TYPE B, THROUGH HOLE, VERTICAL, WITH THRU HOLE SHELL STAKES	
Third Angle Projection	© THIS DRAWING IS CONFIDENTIAL AND MUST NOT BE COPIED OR DISCLOSED WITHOUT WRITTEN CONSENT	

GCT

www.globalconnectortechology.com

Scale	Revision	Material	Drawn by	Sheet No.
NTS	B	See Note	ASE	E & OE 1/2

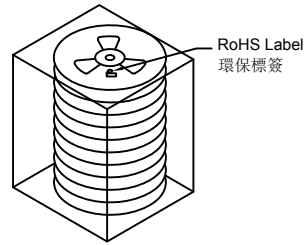
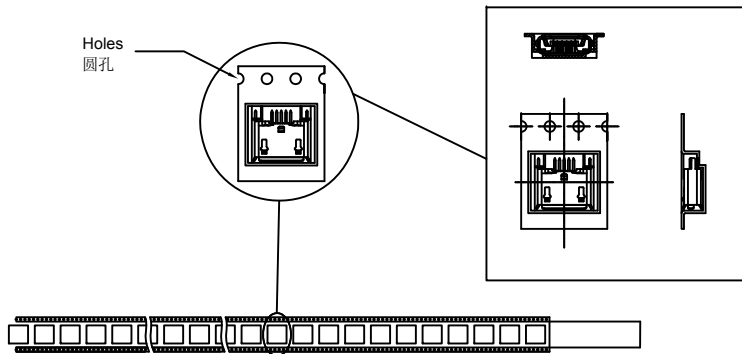

Products P/N	PCS/Reel	Reels/Carton	PCS/Carton
USB3130-30-A	1500	10	15000

Notes注意:

- 1.Part Conforms to EIA-481-C Standards 产品符合EIA-481-C标准
- 2.All dimensions in millimeters 所有尺寸均是毫米
- 3.10 sprocket hole pitch cumulative tolerance ± 0.2 mm

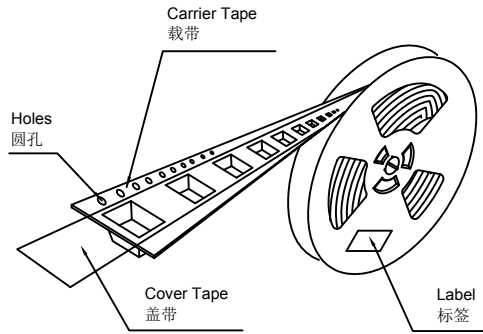
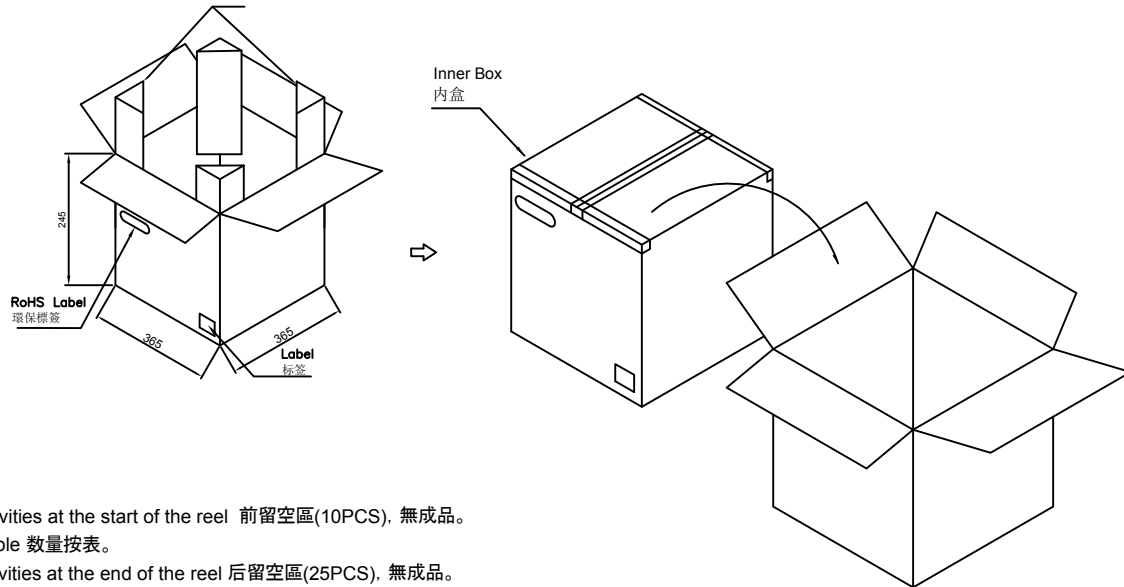
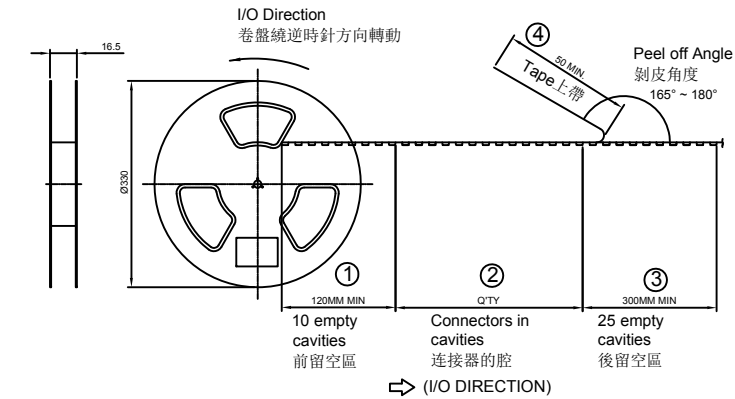

NOTE:

- ① There are 10 empty cavities at the start of the reel 前留空區(10PCS), 無成品。
- ② Quantity as per the Table 数量按表。
- ③ There are 25 empty cavities at the end of the reel 后留空區(25PCS), 無成品。
- ④ There are 50mm tape without the carrier 只有上帶, 無下帶。

By	ASE	CM
DETAIL	DRAWING RELEASE	PCN:- USB3130-001
REV DATE	A 21/10/11	B 23/01/12



Tolerances (Except as noted)	Part Number:-	Date:-
Dimensions in mm	USB3130	21 OCT 11
	Description:-	
	μ USB RECEPTACLE, TYPE B, THROUGH HOLE, VERTICAL, WITH THRU HOLE SHELL STAKES	
Third Angle Projection	© THIS DRAWING IS CONFIDENTIAL AND MUST NOT BE COPIED OR DISCLOSED WITHOUT WRITTEN CONSENT	

GCT

www.globalconnectortech.com

Scale NTS	Revision B	Material See Note	Drawn by ASE	E & OE	Sheet No. 2/2
--------------	---------------	----------------------	-----------------	--------	------------------