

evOLUTION®

www.evolutionbuild.com



Registered Design. Patent Pending 1101605.2.

PW3200 PRESSURE WASHER

ORIGINAL MANUAL

Please read instructions before operating this tool



CONNECT OUTPUT

QUICK REFERENCE GUIDE

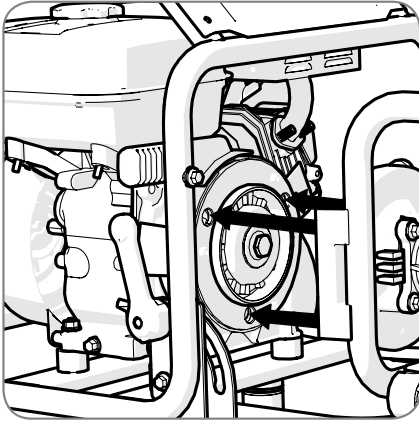

STEP 1...
LINE-UP 3 LOCATING PINS.
AS ARROWS INDICATE

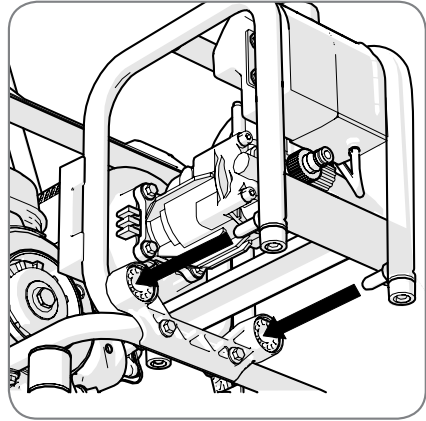

STEP 2...
LINE-UP 2 REAR STABILISER PINS.
AS ARROWS INDICATE

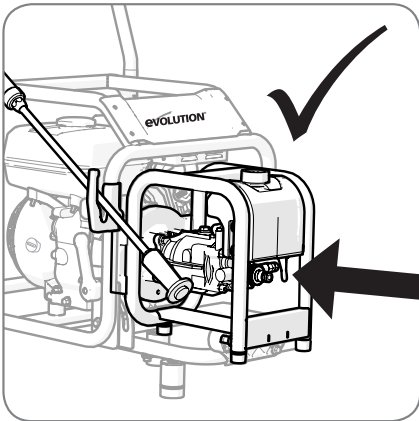

STEP 3...
APPLY GENTLE HORIZONTAL PRESSURE
WITH AN OPEN-HANDED FLAT-PALM.
AS ARROW INDICATES AND LOCK-IN

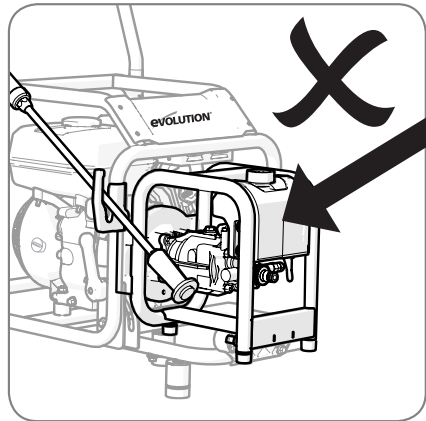

DO NOT...
APPLY SEVERE DIAGONAL DOWN-WARD
PRESSURE AS ARROW INDICATES. DOING
SO MAY DAMAGE THE EVO-SYSTEM!



SEEING IS BELIEVING!

Download a **FREE QR READER APP**
and scan the **QR CODE** (below).

Instantly watch the **HD Evo-System Video** on your Smart Phone.

Make sure the HD setting is on.

If you don't have a Smart Phone, you can also watch all Evolution's videos online.



TABLE OF CONTENTS

EC - Declaration of Conformity	04
Important Information	05
12 Month Limited Warranty	05
General Safety Rules	05
Engine Driven Pressure Washer	07
Additional Specific Safety Rules	07
Symbols & Labels	08
Specification	08
Machine Overview	09
Assembly	11
Operation	13
Maintenance	16
Environmental Protection	16

NOTICE:

A parts diagram can be downloaded from
www.evolutionpowertools.co.uk/evosystem.html

EC - DECLARATION OF CONFORMITY**We, manufacturer and importer**

Evolution Power Tools Ltd.
Venture One
Sheffield
S20 3FR

**Declare that the product
Evo-System PW3200 Pressure Washer**

Part numbers:
PW3200

Complies with the essential requirements of
the following European Directives:

89/336/EEC – EMC Directive
2006/95/EC – Low Voltage Directive
98/37/EEC - Machinery Directive
2000/14/EC – Noise Directive

**The following standards
have been applied:**

EN55014-1:2000/+A1:2001/+A2:2002
EN 55014-2:1997/+A1:2001
EN 61000-3-2:2000/+A2:2005
EN 61000-3-3:1995/+A1:2001
EN 61000-3-11:2000
EN1012-1:1996
EN 60204-1:1997

Authorised by

**Mr Matthew J Gavins**

Managing Director
1 September 2011

**All documentation is held on file at the
above address and is available, on request
for review.**

IMPORTANT

Please read these operating and safety instructions carefully and completely. For your own safety, before using this equipment check that the voltage is correct and that all handles and parts are firmly secured. If you are uncertain about any aspect of using this equipment, **please access our Technical Help Resource.**

UK: 0870 609 2297

E-mail info@evolutionpowertools.com

EVOLUTION Evo-System PW3200 Pressure Washer

Congratulations on your purchase of an Evolution Power Tools Evo-System PW3200 Pressure Washer. Please complete your product registration online to validate your machine's warranty period and ensure prompt service if needed. We sincerely thank you for selecting a product from Evolution Power Tools.

12 MONTH LIMITED WARRANTY.

Evolution Power Tools reserves the right to make improvements and modifications to design without prior notice.

Evolution Power Tools will, within twelve (12) months from the original date of purchase, repair or replace any goods found to be defective in materials or workmanship. This warranty is void if the machine being returned has been used beyond the recommendations in the Instruction Manual or if the machine has been damaged by accident, neglect, or improper service. This warranty does not apply to machines and / or components which have been altered, changed, or modified in any way, or subjected to use beyond recommended capacities and specifications. Electrical components are subject to respective manufacturers' warranties. All goods returned defective shall be returned prepaid freight to Evolution Power Tools. Evolution Power Tools reserves the right to optionally repair or replace it with the same or equivalent item. There is no warranty – written or verbal – for consumables. In no event shall Evolution Power Tools be liable for

loss or damage resulting directly or indirectly from the use of our merchandise or from any other cause. Evolution Power Tools is not liable for any costs incurred on such goods or consequential damages. No officer, employee or agent of Evolution Power Tools is authorised to make oral representations of fitness or to waive any of the foregoing terms of sale and none shall be binding on Evolution Power Tools. Questions relating to this limited warranty should be directed to the company's head office, **or call the appropriate Helpline number.**

GENERAL SAFETY RULES

WARNING: Read all instructions. Failure to follow all instructions listed below may result in electric shock, fire and/or serious injury.

SAVE THESE INSTRUCTIONS

1. Work area safety

- a. Keep work area clean and well lit.** Cluttered and dark areas invite accidents.
- b. Do not operate power tools in explosive atmospheres, such as in the presence of flammable liquids, gases or dust.** Power tools create sparks which may ignite the dust or fumes.
- c. Keep children and bystanders away while operating a power tool.** Distractions can cause you to lose control.

2. Electrical safety

- a. Power tool plugs must match the outlet.** Never modify the plug in any way. Do not use any adapter plugs with earthed (grounded) power tools. Unmodified plugs and matching outlets will reduce risk of electric shock.
- b. Avoid body contact with earthed or grounded surfaces such as pipes, radiators, ranges and refrigerators.** There is an increased risk of electric shock if your body is earthed or grounded.
- c. Do not expose power tools to rain or wet conditions.** Water entering a power tool will increase the risk of electric shock.

d. Do not abuse the cord. Never use the cord for carrying, pulling or unplugging the power tool. Keep cord away from heat, oil, sharp edges or moving parts. Damaged or entangled cords increase the risk of electric shock.

e. When operating a power tool outdoors, use an extension cord suitable for outdoor use. Use of a cord suitable for outdoor use reduces the risk of electric shock.

f. If operating a power tool in a damp location is unavoidable, use a residual current device (RCD) protected supply. Use of an RCD reduces the risk of electric shock.

3. Personal safety

a. Stay alert, watch what you are doing and use common sense when operating a power tool. Do not use a power tool while you are tired or under the influence of drugs, alcohol or medication. A moment of inattention while operating power tools may result in serious personal injury.

b. Use safety equipment. Always wear eye protection. Safety equipment such as dust mask, non-skid safety shoes, hard hat, or hearing protection used for appropriate conditions will reduce personal injuries.

c. Avoid accidental starting. Ensure the switch is in the off-position before plugging in. Carrying power tools with your finger on the switch or plugging in power tools that have the switch on invites accidents.

d. Remove any adjusting key or spanner before turning the power tool on. A spanner or a key left attached to a rotating part of the power tool may result in personal injury.

e. Do not overreach. Keep proper footing and balance at all times. This enables better control of the power tool in unexpected situations.

f. Dress properly. Do not wear loose clothing or jewellery. Keep your hair, clothing and gloves away from moving parts. Loose clothes, jewellery or long hair can be caught in moving parts.

g. If devices are provided for the connection of dust extraction and collection facilities, ensure these are connected and properly used. Use of these devices can reduce dust related hazards.

4. Power tool use and care

a. Do not force the power tool. Use the correct power tool for your application.

The correct power tool will do the job better and safer when used at the rate for which it was designed.

b. Do not use the power tool if the switch does not turn it on and off. Any power tool that cannot be controlled with the switch is dangerous and must be repaired.

c. Disconnect the plug from the power source before making any adjustments, changing accessories, or storing power tools. Such preventive safety measures reduce the risk of starting the power tool accidentally.

d. Store idle power tools out of the reach of children and do not allow persons unfamiliar with the power tool or these instructions to operate the power tool. Power tools are dangerous in the hands of untrained users.

e. Maintain power tools. Check for misalignment or binding of moving parts, breakage of parts and any other condition that may affect the power tools operation.

If damaged, have the power tool repaired before use. Many accidents are caused by poorly maintained power tools.

f. Keep cutting tools sharp and clean. Properly maintained cutting tools with sharp cutting edges are less likely to bind and are easier to control.

g. Use the power tool, accessories and tool bits etc., in accordance with these instructions and in the manner intended for the particular type of power tool, taking into account the working conditions and the work to be performed. Use of the power tool for operations different from intended could result in a hazardous situation.

5. Service

Have your power tool serviced by a qualified repair person using only genuine replacement parts.

This will ensure that the safety of the power tool is properly maintained.

SAFETY INSTRUCTIONS FOR ENGINE DRIVEN PRESSURE WASHER

- a. Petrol or diesel powered engines must never be used in unventilated closed spaces.** The exhaust fumes produced are highly toxic and can cause 'Carbon Monoxide Poisoning' which will cause drowsiness and ultimately death. It is only permissible to run a petrol engine indoors if the building can be very well ventilated and the exhaust fumes can be captured and ducted to the outside through an exhaust extraction/scavenger system.
- b. The Engine/Pressure Washer should be positioned on a firm level surface.** The wheels should be locked, so that the engine cannot move during operation.
- c. The engine should not be run at speeds that exceed the maximum speed on the rating plate.** Operating an engine at excessive speeds increases the likelihood of component failure and consequent accidents.
- d. Do not tamper with components that regulate the engines speed.** You may alter the factory set running parameters.
- e. Use only the type of fuel listed in the Engine Instruction Manual.** Using fuel with an octane rating less than that specified can lead to excessive engine wear and premature engine failure.
- f. Keep the area around the engine clear, clean and tidy.** Never allow any combustible material (timber, plastic, cardboard, canvas etc) near a running engine.
- g. Do not use in or near to potentially explosive atmospheres.** Dust laden atmospheres as can be found in some industrial buildings (Flour Mills, Timber Mills) have an explosive potential.
- h. Regularly check the fuel system for leaks. Hoses and unions should be checked for deterioration or chafing.** Check the fuel tank for damage or for a poorly fitting or worn fuel cap. Any defects must be rectified before the engine is used.
- i. Always stop the engine and allow it to cool down before refuelling.** Try to avoid any fuel spillage (often caused by 'overfilling' the tank) and clean up any spilt fuel immediately. The application of dry sand is an effective way of neutralising fuel spills.
- j. Do not allow the engine to run out of fuel.** Surging of the engine as it uses the last of the fuel could cause damage to connected equipment.

- k. When transporting the engine in a vehicle ensure that the fuel tap is turned off.** To minimise the risk of fuel spillage the engine should be secured by ropes etc to the load area of the vehicle so that it cannot move during transportation. The engine should be secured in as level an attitude as possible.
- l. For long term storage we recommend that the fuel system of the engine is drained.** During long term storage additives in modern fuels can precipitate from the fuel and block jets and valves in the fuel system.
- m. Store the machine in a secure and well ventilated area.** Unauthorised personnel should not have access to this machine.

ADDITIONAL SPECIFIC SAFETY RULES

- a. Never point a pressure washer at yourself or anyone else.** The strong jet from a pressure washer can cause serious wounds or injury. Such wounds may seem minor, but medical treatment should always be sought for any injury as soon as possible.
- b. Never attempt to move or push objects using the power of the jet spray.** The jet spray can throw objects considerable distances. Thrown debris could strike and injure others that are in the vicinity.
- c. Petrol engines should never be used inside buildings or other partially enclosed spaces.** Exhaust fumes from petrol engines are extremely toxic and can cause Carbon Monoxide poisoning. It is only permissible to run a petrol engine indoors if the building can be very well ventilated and the exhaust fumes can be captured and ducted to the outside through an exhaust extraction/scavenger system.
- d. Operators should wear the appropriate PPE (personal protective equipment).** Always wear eye protection. Wear safety shoes. Consider the use of other protective clothing (gloves, boiler suit etc) as appropriate.
- e. Keep bystanders at a safe distance from the workplace.** Debris can be thrown considerable distances by the jet spray. Consider roping or fencing off the work area to keep bystanders and animals at a safe distance.
- f. Only allow competent operators to use this equipment.** Operators should have read and understood the instructions in the Instruction Manual. Children should not be allowed to operate this equipment.

g. Always use a clean, reliable water source. Mains water is best. If mains water is unavailable ensure that the water source is sufficient and adequate for the task at hand.

h. Always start the machine with water supplied. Dry running could cause damage to the equipment.

i. Do not use on or near live electrical equipment. High risk of electric shock. Serious damage to electrical equipment can be caused by the ingestion of water.

j. Always ensure that the spray trigger in the lance handle is in the locked position when the lance is not in use. This will help prevent inadvertent operation.









k. Relieve the pressure in the system before attempting any maintenance or uncoupling hoses etc. Pressure in the system can remain even when the machine is not in use.

l. Observe all safety rules for the operation of the Evolution Evo-System Engine as outlined in the Evo-System Engine Instruction Manual. Observe particularly the refuelling procedures and safety rules.

SPECIFICATION

PRESSURE WASHER SPECIFICATION

Rated Pressure:	175bar (2500psi)
Max Pressure:	220bar (3200psi)
Flow Rate:	8 Litres/Min
Protection:	Thermal Relief Valve
Lance:	2 piece Professional Lance
Hose:	6 metres Reinforced Hose
Detergent System:	Automatic 300ml Reservoir
Weight:	8.1kg

Symbol	Description
	Read the Manual
	Wear Safety Goggles
	Wear Ear Protection
	Wear Dust Protection
	Warning
	CAUTION: Hot exhaust Do not touch
	CAUTION: This is a 4 stroke engine. Fill with petrol only. Do not fill with diesel oil.
	Allow motor to cool before opening the fuel cap. The vapour is extremely flammable and may ignite on contact with a hot surface or flames.

Machine Overview

General view of Pressure Washer connected to the Evolution Evo-System Engine

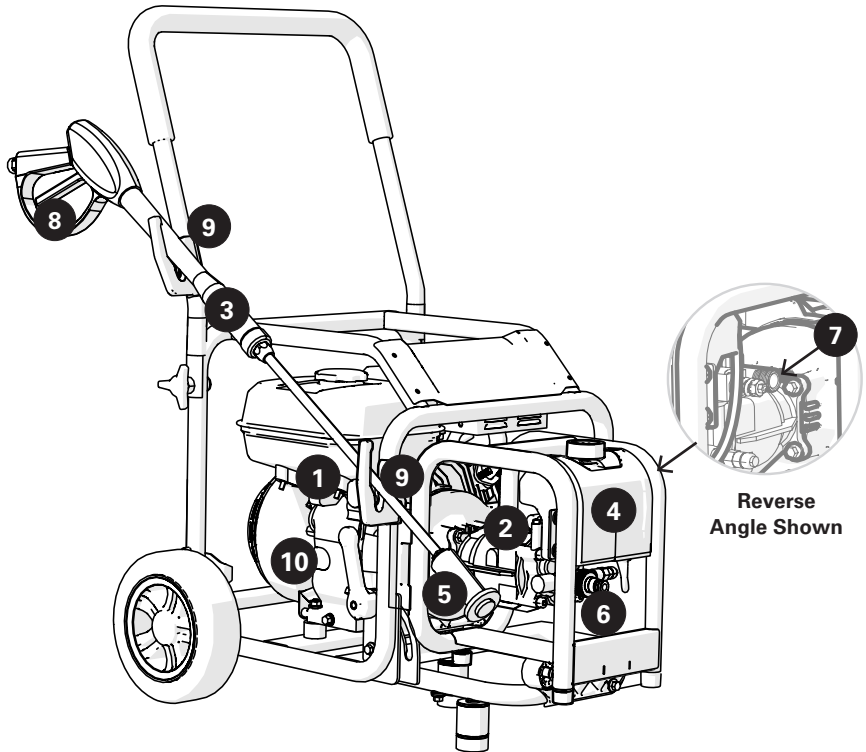

- | | |
|--------------------------------|-----------------------------------|
| 1. Evolution Evo-System engine | 6. Water inlet port |
| 2. PW3200 Pressure Washer | 7. Pump/Outlet Port |
| 3. Pressure Washer Lance | 8. Pressure Washer Safety Trigger |
| 4. Detergent Reservoir | 9. Handle attachment hooks |
| 5. Adjustable Nozzle | 10. Engine On/Off switch |

Machine Overview

General view of Pressure Washer connected to the Evolution Evo-System Engine

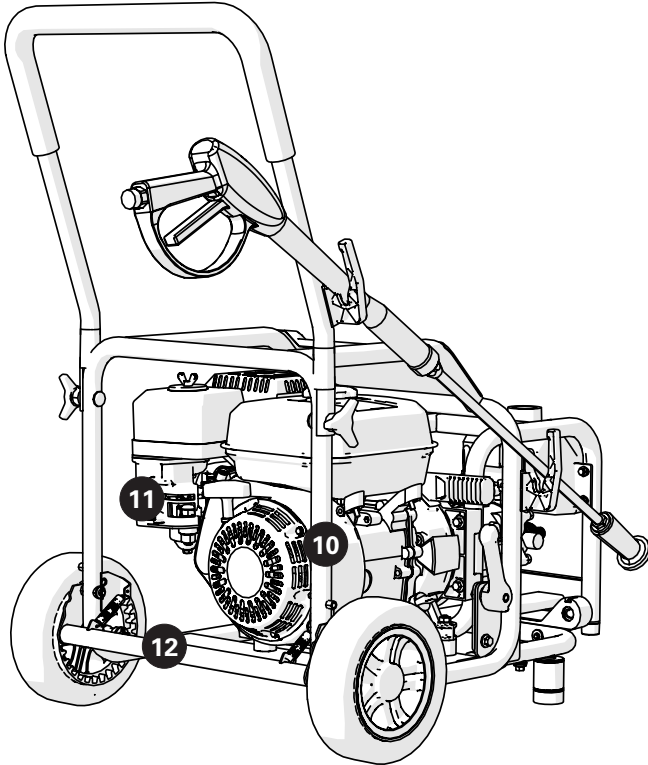

10. Engine On/Off switch

11. Choke/ Fuel Tap on/off

12. Foot brake

ASSEMBLY

1. Connecting the PW3200 Pressure Washer to the Evolution Evo-System Engine

Note: Your Evolution Pressure Washer is designed to be connected to and powered by the Evo-System Engine. Do not try to connect this machine to any other power source. Your Evo-System Engine has a unique coupling that enables a variety of Evolution accessories to be connected to and be driven by this machine. This coupling is engineered to very fine tolerances and must be kept clean and free from dirt, debris etc. A cover for coupling protection is provided with each accessory and should be used whenever the accessory is 'remote' from the engine. If you experience difficulty in accessory connection, it could be because the accessory location pins, or the annuli of either the accessory or the engine are contaminated or damaged.

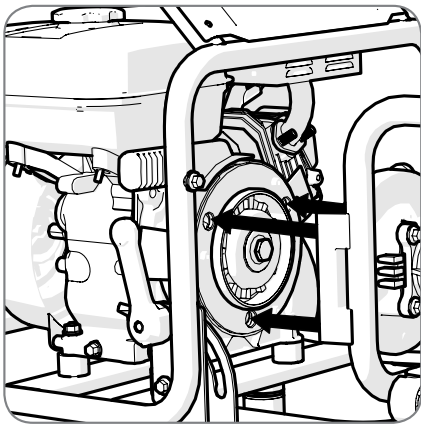

Fig 1a (showing 3 locating pins)

Preparing the engine for accessory connection:

Note: The Evo-System Engine has a micro switch incorporated within the coupling design that senses when an accessory has been successfully attached to the machine. The engine will not start without an accessory being successfully connected. It cannot be run as a 'stand alone' machine.

- Lock the Transportation Wheels using the wheel brake.
- Release the Accessory Mounting Frame by rotating the locking levers to their unlocked (down) position and push-in.
- Deploy the Accessory Mounting Frame.
- Lock the frame into position by pulling out and then returning the locking levers to their locked (upright) position.

Pressure Washer connection

Note: The Pressure Washer is equipped with 3 locating pins (Fig. 1a) and 2 rear stabilising pins. The 3 locating pins lock into the 'Uni-coupling'. The other 2 stabilising pins slide into the sockets in the Accessory Mounting Frame. (Fig.1b)

- Hold the accessory by its external frame and offer it up to the engine. Visually align the 3 locating pins and 2 rear stabilising pins. Enlist competent help if necessary.
- Holding onto a convenient part of the external engine frame can aid the operator achieving and maintaining alignment when connecting an accessory.

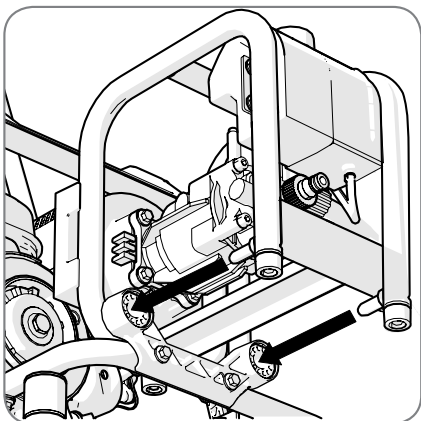

Fig 1b (showing 2 rear stabiliser pins)

- Gently push the accessory into the engine. Keep the 3 locating pins and the 2 stabilising pins aligned with their respective docking positions. The internal coupling between the engine and the accessory will be made automatically. No component alignment or adjustments are necessary.
- Be gentle and patient, the coupling is precisely engineered and no great force is required to connect the accessories. Once the operator has mastered the 'technique', accessory connection will become straight forward.
- Firmly push the engine and accessory together until the 'click' of docking is heard. The Uni-coupling release lever will return to its neutral position.

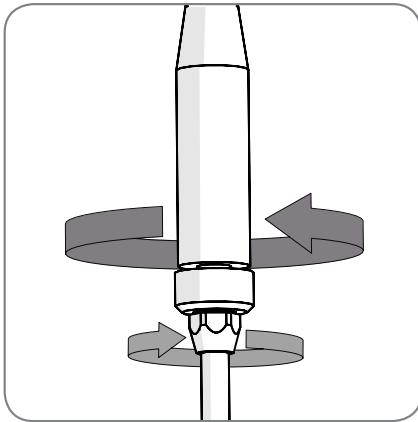

Fig 2

2. Jet Lance Assembly

The jet lance is supplied in two parts.

To assemble:

- Offer up the lower lance to the lance body.
- Tighten fully the large hand nut to pull the two parts of the lance together. **(Fig. 2)**

3. Connecting the High Pressure Hose

Note: The two ends of the High Pressure Hose look identical. However the diameter of the hose unions is slightly different. The larger diameter union is for connection to the pump outlet port. The smaller diameter union is for connection to the lance handle inlet port. The High Pressure Hose can only be fitted one way round.

- Push the hose into the relevant port. **(Fig. 3)**
- Securely tighten the large hand nut to pull the hose union fully into the port.

Note: A very light smear of petroleum jelly applied to the rubber sealing rings can aid assembly of the hose connections.

4. Connecting to the Water Supply

Note: We recommend that where ever possible this machine is connected to the mains water supply. If this is not possible the operator must ensure that the water supply is clean and sufficient for the task at hand. A filter (not supplied) may be necessary, particularly if there is any doubt about the quality, purity and cleanliness of the supply.

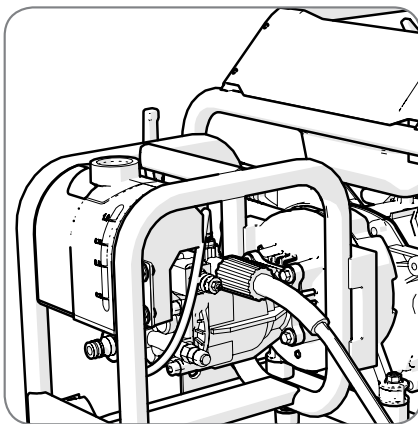

Fig 3

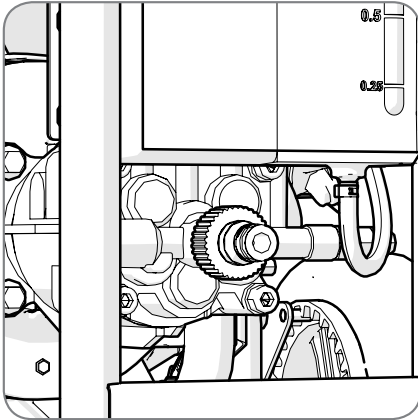

Fig. 4

Note: The inlet port of the pressure pump is fitted with a standard 1" BSP female thread Tap Connector. The quick fit hose connect (supplied) can be fitted here. (Fig. 4)

The operator should purchase or make up a suitable length of hose to connect the machine to a convenient water tap.

One end of the hose should be fitted with a standard hose end connector (for connection to the pump). The other end of the hose should be fitted with a suitable connector(s) for the tap to which it is to be connected.

Note: Connection to the public mains water supply may be subject to local regulations. Check with the water provider for any restrictions that might apply.

Note: When using a water tank as a supply, ensure that a filter is fitted to the end of the hose immersed in the tank. Attach the other end directly to the inlet port using a standard 1" BSP hose end connector (not supplied). A quick fit connector is not suitable for a water tank application.

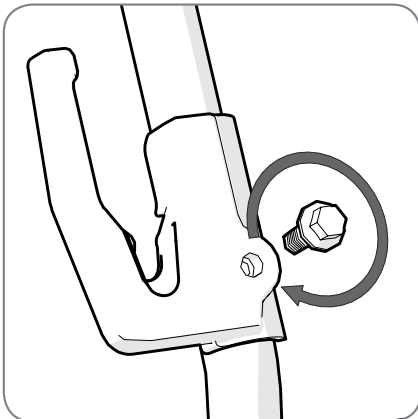

Fig. 5

5. Jet Lance Storage Hooks

The Pressure Washer is supplied with two storage hooks. These hooks can be attached to the Evo-System Engines external frame if required and provide a convenient storage position for the Jet Lance during operations.

- Remove the two attachment bolts. (Fig. 5)
- Install the two hooks on the frame. The hooks are identical and will only fit one way round. Tighten the attachment bolts securely.

OPERATION

Initial preparation

WARNING: This is a very powerful piece of equipment. All safety rules and advice must be heeded. Failure to use this equipment correctly could result in serious injury to the operator or others.

1. Siting the Equipment

Note: The Evolution Evo-System Engine with the Power Washer attached should be sited with reference to the instructions given in the Evolution Evo-System Engine Instruction Manual (SAFETY INSTRUCTIONS FOR EVO-SYSTEM ENGINE).

Site the equipment and check:

- The equipment is as level as possible.
- The wheel brake is applied.
- The surface is firm and stable.
- No combustible materials are close by.
- The area is well ventilated, and that there is no danger from the expelled exhaust gases.

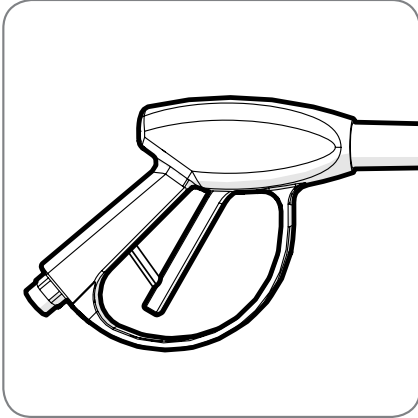

Fig. 6

Note: The Evo-System Engine is fitted with a low oil level shut down feature which protects the engine from damage due to lack of lubrication. This feature could be activated if the machine is sited on a slope of greater than 10°.

2. Preparing the Evolution Evo-System Engine

Note: Refer to the Instruction Manual for the Evo-System Engine.

- Check the Fuel Level.
- Check the Oil Level.
- Visually check all fuel lines and electrical connections.

3. Starting the Engine

Note: Refer to the Instruction Manual for the Evo-System Engine

- Check that the trigger switch on the jet lance is in the locked position. (**Fig. 6**)
- Check the integrity of all hose connections.
- Turn on the water supply to the pump and allow water to run into the pump.
- Start the engine.
- Allow the engine to reach its normal operational temperature.

4. The Lance Nozzle

Note: The Jet Lance has an adjustable outlet nozzle. (**Fig. 7**)

- Pull the nozzle downwards to access 'low pressure mode'.
- Pull the nozzle upwards to access 'high pressure mode'.

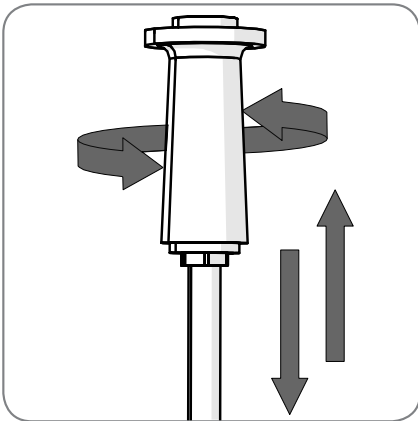
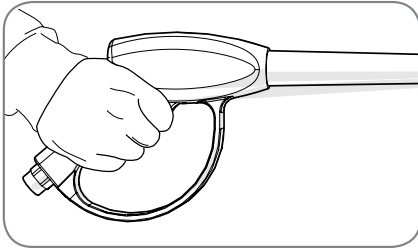

Fig. 7

In either setting, rotating the nozzle to the right, (as seen from the handle) will result in the water jet emitted from the nozzle being 'fan' shaped.

In either setting, rotating the nozzle to the left, (as seen from the handle) will result in the water jet emitted from the nozzle being a thin stream.

5. Using the Jet Lance



WARNING: The Operator must hold the Jet Lance with both hands. It is dangerous to attempt to use the Jet Lance with one hand. A hand grip is provided approximately half way down the Jet Lance wand. **(Fig. 8)**

Note: The output pressure of the Jet Lance is dependent upon the speed of the engine.

- Release the trigger safety locking lever.
- Gently squeeze the trigger to allow the high pressure water through the lance.

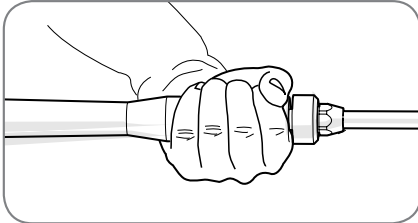

Note: We recommend that any adjustment to the Nozzle setting is completed before water is allowed to flow through the lance.

WARNING: The operator should never allow either of their hands to be in front of the Jet Lance Nozzle. The Lance must never be pointed at another person or animal or at any electrical socket etc.

Fig. 8

6. Detergent Application

Note: We recommend that only high quality, low foaming, biodegradable detergent that is specifically formulated for use in pressure washers is used in this machine. The operator should follow the manufacturers advice on the application and handling of the product. Avoid skin contact with the detergent.

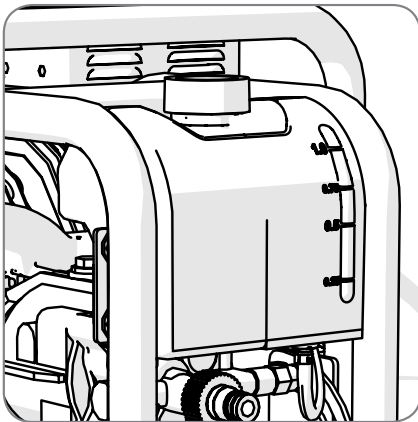

A detergent reservoir is incorporated into the external frame of the power washer module. **(Fig. 9)**. When required this reservoir should be filled with high quality detergent specially formulated for use in power washers. Do not pre-wet the area to be cleaned as this will only dilute the detergent and reduce its cleaning ability. Allow the detergent to remain on the surface for a few minutes before rinsing with the Jet Lance set to 'high pressure mode'.

Fig. 9

Note: Detergent application is automatic but will only occur when the Jet Lance is in 'low pressure' mode. (Refer to 4. The Lance Nozzle above)

The reservoir is 'see - through' so that the operator can monitor detergent usage.

MAINTENANCE AND WINTER STORAGE

Some limited maintenance is required to ensure that your pressure washer gives good service for many years.

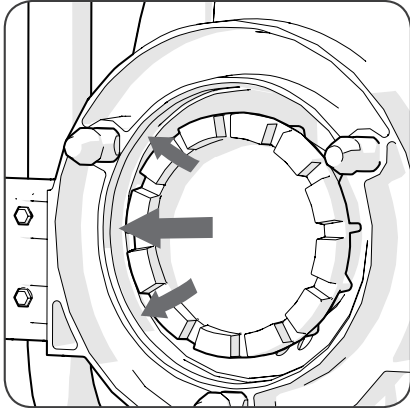

Fig 10 (arrows show inner wall of annular ring)

- Keep the annular ring scrupulously clean and free from debris. (**Fig. 10**)
- Keep the 3 locating pins and 2 stabilising pins clean and occasionally spray coat with a silicone oil based spray. (**Fig. 11**)
- Keep all Uni-coupling mating surfaces clean and free from dirt or debris.
- At every connection or disconnection check the accessory drive cog for dirt or debris contamination, particularly between the teeth. Clean and lubricate as per the instructions for the engine drive clutch.
- Whenever the accessory is 'remote' from the engine the coupling protection cover (provided) should be used to protect the coupling.
- Avoid spraying cog teeth with silicone oil.

Winter storage

We recommend that both hoses (water input and high pressure water output) are removed from the pump.

Drain the pump body of any residual water by tipping the pump on its side. Any water left in the pump body will drain through the pump outlet port. .

Drain the detergent reservoir.

Store in a secure, frost free, dry location, covered by a clean cloth to prevent the ingress of dirt, debris etc.

We recommend that the two hoses (water inlet and high pressure) are also drained of any residual water before being coiled and placed into a suitable plastic bag for winter storage. The Jet Lance should also be drained of water and stored in a suitable plastic bag. The Lance can be dismantled into its two main parts if this makes storage easier.

ENVIRONMENTAL PROTECTION

Waste electrical or mechanical products should not be disposed of with household waste. Please recycle where facilities exist. Check with your Local Authority or retailer for recycling advice.

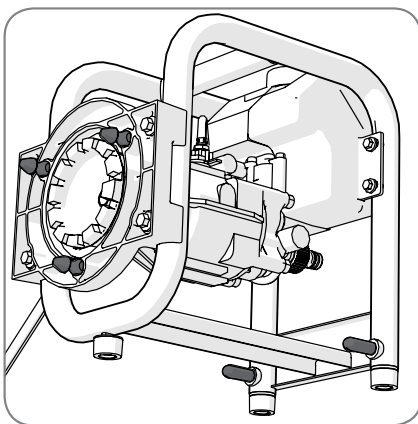
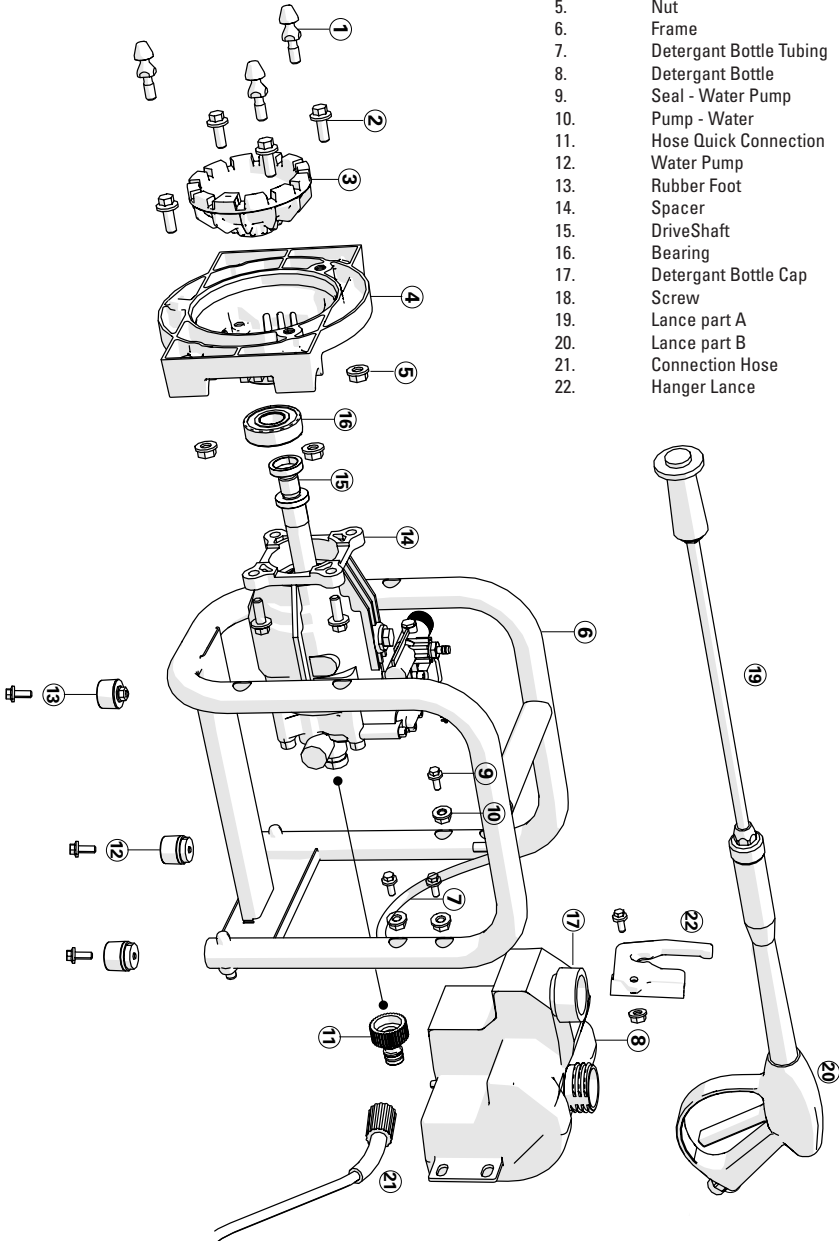

Fig. 11

PARTS DIAGRAM

No.	Description	QTY
1.	Pin - Locking	3
2.	Screw	4
3.	Hub - Accessory	1
4.	Adaptor -Pressure Washer	1
5.	Nut	4
6.	Frame	1
7.	Detergant Bottle Tubing	1
8.	Detergant Bottle	1
9.	Seal - Water Pump	1
10.	Pump - Water	1
11.	Hose Quick Connection	1
12.	Water Pump	1
13.	Rubber Foot	3
14.	Spacer	1
15.	DriveShaft	1
16.	Bearing	1
17.	Detergant Bottle Cap	1
18.	Screw	1
19.	Lance part A	1
20.	Lance part B	1
21.	Connection Hose	1
22.	Hanger Lance	2



DID YOU KNOW YOU CAN ALSO BUY...

ENGINE UNIT

- ✓ Wheel kit provides mobility.
- ✓ Folding handle for storage.
- ✓ Robust & durable steel frame.

• Power: 6.5hp, 4-Stroke • Power Take Off (PTO)
• Easy Recoil Start • Fuel Capacity: 3.1L • EV0200

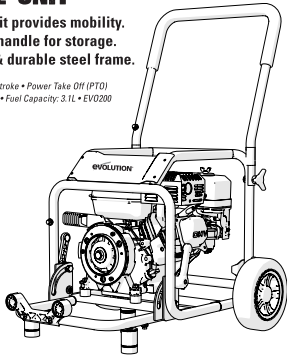

EVO-SYSTEM ENGINE

WATER PUMP

- ✓ Pumps 1000L per minute.
- ✓ Inlet filter prevents unwanted debris from entering the pump.

• Use With: 3" (75mm) Hose • Suction Height: 8m
• Pump Lift: 26m • DVP1000

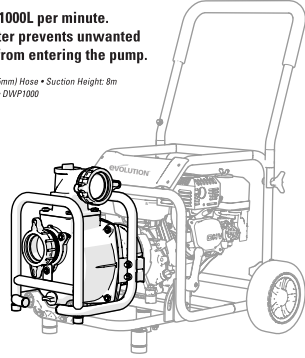

WATER PUMP OUTPUT

PRESSURE WASHER

- ✓ High quality brass pump.
- ✓ Includes lance with adjustable nozzle & hose.
- ✓ Built-in detergent system.

• Max. Flow Rate: 8L/min • Rated Pressure: 175bar
• Max. Pressure: 220bar • PW2300

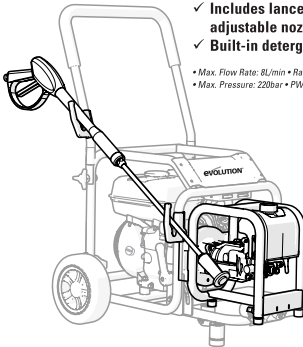

PRESSURE WASHER OUTPUT

GENERATOR

- ✓ Switchable voltages.
- ✓ Thermal cut-outs.
- ✓ Automatic voltage regulation.

• Power: 2400W (Continuous) • AC Output
• Sockets: 1 x 110V & 1 x 230V • GEN200

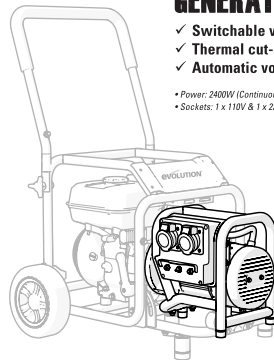

GENERATOR OUTPUT



Registered Design. Patent Pending 1101605.2.

...WITH MORE OUTPUTS AVAILABLE SOON!