

## LCD Monitor S275HL

# Modern look, impressive performance

- Ultra-slim profile
- Sleek, asymmetric design
- Energy-efficient, earth-friendly
  - White LED technology
  - Up to 68% power savings
- 1920 x 1080 Full HD resolution
- 100 million:1 contrast ratio
- Two HDMI® ports for exceptional high-definition viewing



# Specifications

Panel	Display Size	27" (16:9)	
	Active display area	59.7 x 33.6 cm	
	Maximum Resolution and Refresh Rate	1920 x 1080 @ 60 Hz	
	Glare (Y/N)	Y	
	Response Time	6 ms	
	Contrast Ratio	100 million:1 (ACM)	
	Brightness	250 nits (cd/m <sup>2</sup> )	
	Viewing Angle	178° (H), 178° (V)	
	Colors	16.7 million	
	Bits	6 + adv-FRC	
System	Input Signal	VGA + two HDMI® (with HDCP)	
	Output Signal	Audio jack (only supported when the input signal is HDMI®)	
	Speaker	1.5 W x 2	
	Power Supply (100 - 240 V)	External adapter	
	Tilt	-1° to 15°	
	Power Consumption (ENERGY STAR®)	Off	0.5 W (typical)
Sleep		0.5 W (typical)	
On		36 W (typical)	

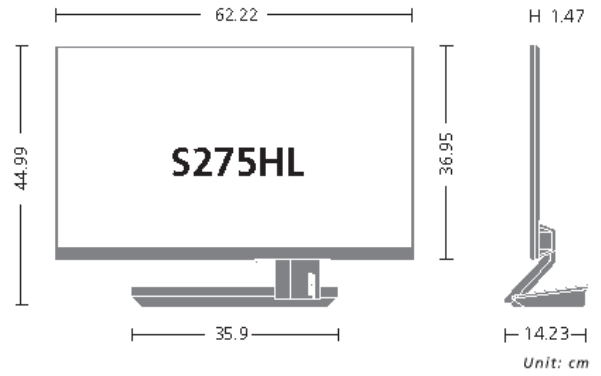

### Full HD LED monitor

The 1920 x 1080 resolution of this LED monitor delivers excellent detail, making it perfect for advanced 1080p Full HD gaming, multimedia and productivity applications, providing advantages such as:

- Blu-ray Disc™ console gaming
- Widescreen cinematic playback



### Dependable functionality

This monitor complies with the latest Windows® 7 operating systems; has undergone rigorous durability testing; and adheres to high safety standards to ensure reliability and comfortable viewing.



### Acer eColor Management

A single button — the Empowering Key — grants full access to the Acer eColor Management onscreen interface. Acer eColor Management provides a variety of advanced controls for achieving the best-possible image quality.



### Acer EcoDisplay

Acer monitors using white LED backlight technology minimize environmental impact while providing superior performance and durability. These monitors do not contain the toxic substance *mercury*, making them safer for the environment. They also consume less power and last longer than monitors with CCFL lamps, for good savings.



### About Acer

Since its founding in 1976, Acer has broken barriers between people and technology, enabling users to explore, create and grow. Acer ranks No. 2 for notebook PCs globally (Gartner data 2011). The Acer Group employs 8,000 people across the globe, and revenues for 2011 reached US\$15.7 billion.

Acer's channel business model is instrumental to the company's success, while its multi-brand approach integrates Acer, Gateway, and Packard Bell brands in worldwide markets. Acer designs environmentally friendly products and, with its vendors, has established a green supply chain.

Acer is proud to be a Worldwide Partner of the Olympic Movement. That includes supporting the Vancouver 2010 Olympic Winter Games and London 2012 Olympic Games. More information is at [www.acer-group.com](http://www.acer-group.com).

