

Wave ESD

Industrial magnifier with 3D feature

LUXO



Description

Wave ESD is especially made for the electronics industry where electrostatic discharges can prove fatal for electronic components. Wave ESD is designed to drain away static charges as they occur in a controlled manner.

Wave ESD is the only magnifier to offer both shadow-free magnification with light coming from both sides, as well as three-dimensional magnification with light coming from the left or right. The 3D-feature is especially welcome when working with circuit boards or similar delicate objects.

Excellent viewing conditions

By illuminating from one side only, depth perception is increased and positioning of the objects are made easier. The large rectangular lens, 175 x 108 mm, permits comfortable viewing with both eyes. The slim edge in front of the lens ensures that eye contact with the object viewed is not lost when switching from magnification to normal viewing and back again. The neck joint between the head and arm moves in three planes: horizontally, vertically and laterally making exact positioning easy.

Colour: Black.

Standard version with 3,5 diopter lens and table clamp

Wave ESD

Industrial magnifier with 3D feature



Technical description

LIGHT SOURCE

Supplied with 2 x TC-S 7 W. Individual power on/off.

BALLAST

Magnetic ballast.

BODY MATERIAL & COLOUR

ESD coated steel arm and plastic shade. Colour: black

MOUNTING

Standard with table clamp (AN clamp). Other table clamps, integrated table mounts and trolley are available on request.

OPTICS

Standard with 3.5 diopter crown glass lens. Lens dimensions are 175 x 108 mm. An accessory 4 diopter lens and 10 diopter swing-away lens are available on request. Aluminium reflector.

ARM TECHNOLOGY & MOVEMENT

Parallel, three-pivot arm. Arm length is 105 cm.

Wave ESD

Industrial magnifier with 3D feature



Illustrations



Wave ESDWave ESD is designed to drain away electrostatic discharges in a controlled manner.

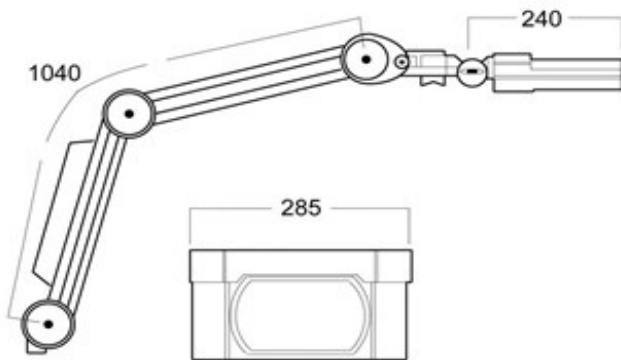

Wave ESD