



# Off-line Power Supply Controller

## FEATURES

- Transformerless Off-line Applications
- Ideal Primary-side Bias Supply
- Efficient BiCMOS Design
- Wide Input Range
- Fixed or Adjustable Low Voltage Output
- Uses Low Cost SMD Inductors
- Short Circuit Protected
- Optional Isolation Capability

## DESCRIPTION

The UCC1889 controller is optimized for use as an off-line, low power, low voltage, regulated bias supply. The unique circuit topology utilized in this device can be visualized as two cascaded flyback converters, each operating in the discontinuous mode, and both driven from a single external power switch. The significant benefit of this approach is the ability to achieve voltage conversion ratios of 400V to 12V with no transformer and low internal losses.

The control algorithm utilized by the UCC1889 is to force the switch on time to be inversely proportional to the input line voltage while the switch off time is made inversely proportional to the output voltage. This action is automatically controlled by an internal feedback loop and reference. The cascaded configuration allows a voltage conversion from 400V to 12V to be achieved with a switch duty cycle greater than 10%. This topology also offers inherent short circuit protection since as the output voltage falls to zero, the switch off time approaches infinity.

The output voltage can be easily set to 12V or 18V. Moreover, it can be programmed for other output voltages less than 18V with a few additional components. An isolated version can be achieved with this topology as described further in Unitrode Application Note U-149.

## OPERATION

With reference to the application diagram below, when input voltage is first applied, the  $R_{ON}$  current into  $T_{ON}$  is directed to  $V_{CC}$  where it charges the external capacitor,  $C_3$ , connected to  $V_{CC}$ . As voltage builds on  $V_{CC}$ , an internal undervoltage lockout holds the circuit off and the output at  $DRIVE$  low until  $V_{CC}$  reaches 8.4V. At this time,  $DRIVE$  goes high turning on the power switch,  $Q_1$ , and redirecting the current into  $T_{ON}$  to the timing capacitor,  $C_T$ .  $C_T$  charges to a fixed threshold with a current  $I_{CHG} = 0.8 \cdot (V_{IN} - 4.5V) / R_{ON}$ . Since  $DRIVE$  will only be high for as long as  $C_T$  charges, the power switch on time will be inversely proportional to line voltage. This provides a constant line voltage-switch on time product.

## TYPICAL APPLICATION

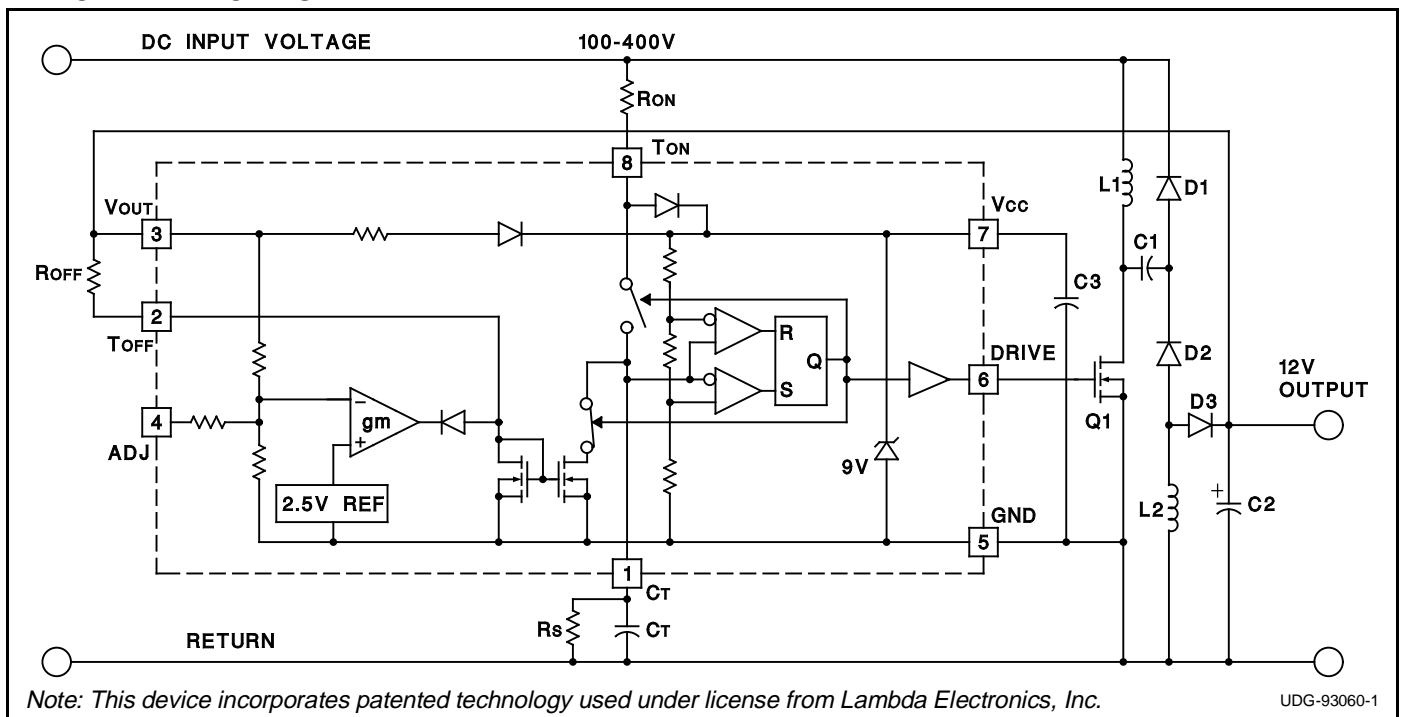

### OPERATION (cont.)

At the end of the on time, Q1 is turned off and the RON current into TON is again diverted to VCC. Thus the current through RON, which charges CT during the on time, contributes to supplying control power during the off time.

The power switch off time is controlled by the discharge of CT which, in turn, is programmed by the regulated output voltage. The relationship between CT discharge current, IDCHG, and output voltage is illustrated as follows:

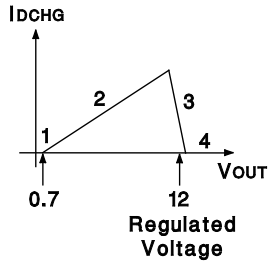

1. When  $V_{OUT} = 0$ , the off time is infinite. This feature provides inherent short circuit protection. However, to ensure output voltage startup when the output is not a short, a high value resistor,  $R_S$ , is placed in parallel with  $C_T$  to establish a minimum switching frequency.
2. As  $V_{OUT}$  rises above approximately 0.7V to its regulated value,  $I_{DCHG}$  is defined by  $R_{OFF}$ , and therefore is equal to:

$$I_{DCHG} = (V_{OUT} - 0.7V) / R_{OFF}$$

As  $V_{OUT}$  increases,  $I_{DCHG}$  increases resulting in the reduction of off time. The frequency of operation increases and  $V_{OUT}$  rises quickly to its regulated value.

3. In this region, a transconductance amplifier reduces  $I_{DCHG}$  in order to maintain  $V_{OUT}$  in regulation.
4. If  $V_{OUT}$  should rise above its regulation range,  $I_{DCHG}$  falls to zero and the circuit returns to the minimum frequency established by  $R_S$  and  $C_T$ .

The range of switching frequencies is established by  $R_{ON}$ ,  $R_{OFF}$ ,  $R_S$ , and  $C_T$  as follows:

$$\text{Frequency} = 1 / (T_{ON} + T_{OFF})$$

$$T_{ON} = R_{ON} \cdot C_T \cdot 4.6 V / (V_{IN} - 4.5V)$$

$$T_{OFF} (\text{max}) = 1.4 \cdot R_S \cdot C_T$$

Regions 1 and 4

$$T_{OFF} = R_{OFF} \cdot C_T \cdot 3.7V / (V_{OUT} - 0.7V)$$

Region 2, excluding the effects of  $R_S$  which have a minimal impact on  $T_{OFF}$ .

The above equations assume that  $V_{CC}$  equals 9V. The voltage at  $T_{ON}$  increases from approximately 2.5V to 6.5V while  $C_T$  is charging. To take this into account,  $V_{IN}$  is adjusted by 4.5V in the calculation of  $T_{ON}$ . The voltage at  $T_{OFF}$  is approximately 0.7V.

### DESIGN EXAMPLE

The UCC3889 regulates a 12 volt, 1 Watt nonisolated DC output from AC inputs between 80 and 265 volts. In this example, the IC is programmed to deliver a maximum on time gate drive pulse width of 2.4 microseconds which occurs at 80 VAC. The corresponding switching frequency is approximately 100kHz at low line, and overall efficiency is approximately 50%. Additional design information is available in Unitrode Application Note U-149.

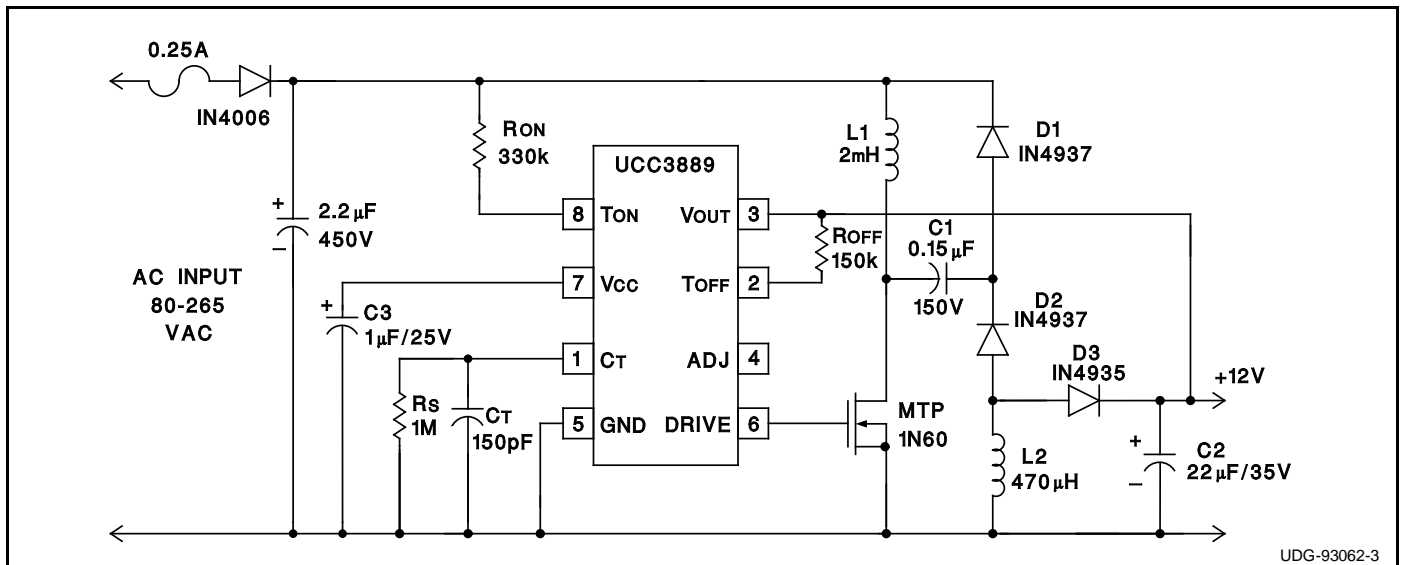

UDG-93062-3

**ABSOLUTE MAXIMUM RATINGS**

ICC . . . . . 5mA  
 Current into TON Pin . . . . . 1.5mA  
 Voltage on VOUT Pin . . . . . 20V  
 Current into TOFF Pin . . . . . 250µA  
 Storage Temperature . . . . . -65°C to +150°C

Note: Unless otherwise indicated, voltages are referenced to ground and currents are positive into, negative out of, the specified terminals.

**CONNECTION DIAGRAM**

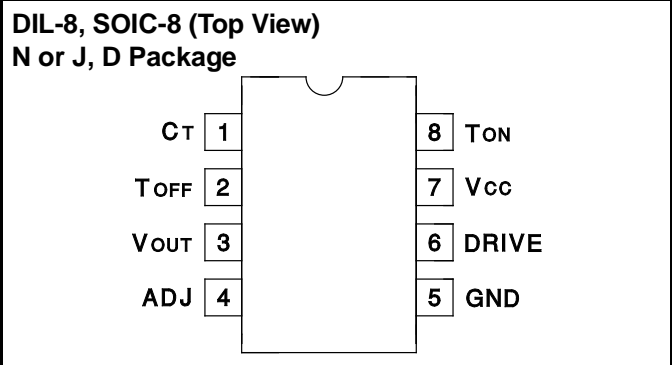

**ELECTRICAL CHARACTERISTICS** Unless otherwise stated, these specifications hold for TA = 0°C to 70°C for the UCC3889, -40°C to +85°C for the UCC2889, and -55°C to +125°C for the UCC1889. No load at DRIVE pin (CLOAD=0).

PARAMETER	TEST CONDITIONS	MIN	TYP	MAX	UNITS
<b>General</b>					
Vcc Zener Voltage	ICC < 1.5mA	8.6	9.0	9.3	V
Startup Current	VOUT = 0		150	250	µA
Operating Current I(VOUT)	VOUT = 11V, F = 150kHz		1.2	2.5	mA
<b>Under-Voltage-Lockout</b>					
Start Threshold	VOUT = 0	8.0	8.4	8.8	V
Minimum Operating Voltage after Start	VOUT = 0	6.0	6.3	6.6	V
Hysteresis	VOUT = 0	1.8			V
<b>Oscillator</b>					
Amplitude	Vcc = 9V	3.5	3.7	3.9	V
CT to DRIVE high Propagation Delay	Overdrive = 0.2V		100	200	ns
CT to DRIVE low Propagation Delay	Overdrive = 0.2V		50	100	ns
<b>Driver</b>					
VOL	I = 20mA, Vcc = 9V		0.15	0.4	V
	I = 100mA, Vcc = 9V		0.7	1.8	V
VOH	I = -20mA, Vcc = 9V	8.5	8.8		V
	I = -100mA, Vcc = 9V	6.1	7.8		V
Rise Time	CLOAD = 1nF		35	70	ns
Fall Time	CLOAD = 1nF		30	60	ns
<b>Line Voltage Detection</b>					
Charge Coefficient: ICHG / I(TON)	VCT = 3V, DRIVE = High, I(TON) = 1mA	0.73	0.79	0.85	
Minimum Line Voltage for Fault	RON = 330k	60	80	100	V
Minimum Current I(TON) for Fault	RON = 330k		220		µA
On Time During Fault	CT = 150pF, VLINE = Min - 1V		2		µs
Oscillator Restart Delay after Fault			0.5		ms
<b>Vout Error Amp</b>					
VOUT Regulated 12V (ADJ Open)	Vcc = 9V, IDCHG = I(TOFF)/2	11.2	11.9	12.8	V
VOUT Regulated 18V (ADJ = 0V)	Vcc = 9V, IDCHG = I(TOFF)/2	16.5	17.5	19.5	V
Discharge Ratio: IDCHG / I(TOFF)	I(TOFF) = 50µA	0.93	1.00	1.07	
Voltage at TOFF	I(TOFF) = 50µA	0.6	0.95	1.3	V
Regulation gm (Note 1)	Max IDCHG = 50µA		1.0		mA/V
	Max IDCHG = 125µA	0.8	1.7	2.9	mA/V

Note 1: gm is defined as  $\frac{\Delta I_{DCHG}}{\Delta V_{OUT}}$  for the values of VOUT when VOUT is in regulation. The two points used to calculate gm are for IDCHG at 65% and 35% of its maximum value.

**PIN DESCRIPTIONS**

**ADJ:** The ADJ pin is used to provide a 12V or an 18V regulated supply without additional external components. To select the 12V option, ADJ pin is left open. To select the 18V option, ADJ pin must be grounded. For other output voltages less than 18V, a resistor divider between VOUT, ADJ and GND is needed. Note, however, that for output voltages less than VCC, the device needs additional bootstrapping to VCC from an external source such as the line voltage. If so, precautions must be taken to ensure that total ICC does not exceed 5mA.

**CT (timing capacitor):** The signal voltage across CT has a peak-to-peak swing of 3.7V for 9V VCC. As the voltage on CT crosses the oscillator upper threshold, DRIVE goes low. As the voltage on CT crosses the oscillator lower threshold, DRIVE goes high.

**DRIVE:** This output is a CMOS stage capable of sinking 200mA peak and sourcing 150mA peak. The output voltage swing is 0 to VCC.

**GND (chip ground):** All voltages are measured with respect to GND.

**TOFF (regulated output control):** TOFF sets the discharge current of the timing capacitor through an external

resistor connected between VOUT and TOFF.

**TON (line voltage control):** TON serves three functions. When CT is discharging (off time), the current through TON is routed to VCC. When CT is charging (on time), the current through TON is split 80% to set the CT charge time and 20% to sense minimum line voltage which occurs for a TON current of 220µA. For a minimum line voltage of 80V, RON is 330kΩ.

The CT voltage slightly affects the value of the charge current during the on time. During this time, the voltage at the TON pin increases from approximately 2.5V to 6.5V.

**VCC (chip supply voltage):** The supply voltage of the device at pin VCC is internally clamped at 9V. Normally, VCC is not directly powered from an external voltage source such as the line voltage. In the event that VCC is directly connected to a voltage source for additional bootstrapping, precautions must be taken to ensure that total ICC does not exceed 5mA.

**VOUT (regulated output):** The VOUT pin is directly connected to the power supply output voltage. When VOUT is greater than VCC, VOUT bootstraps VCC.

**BLOCK DIAGRAM**

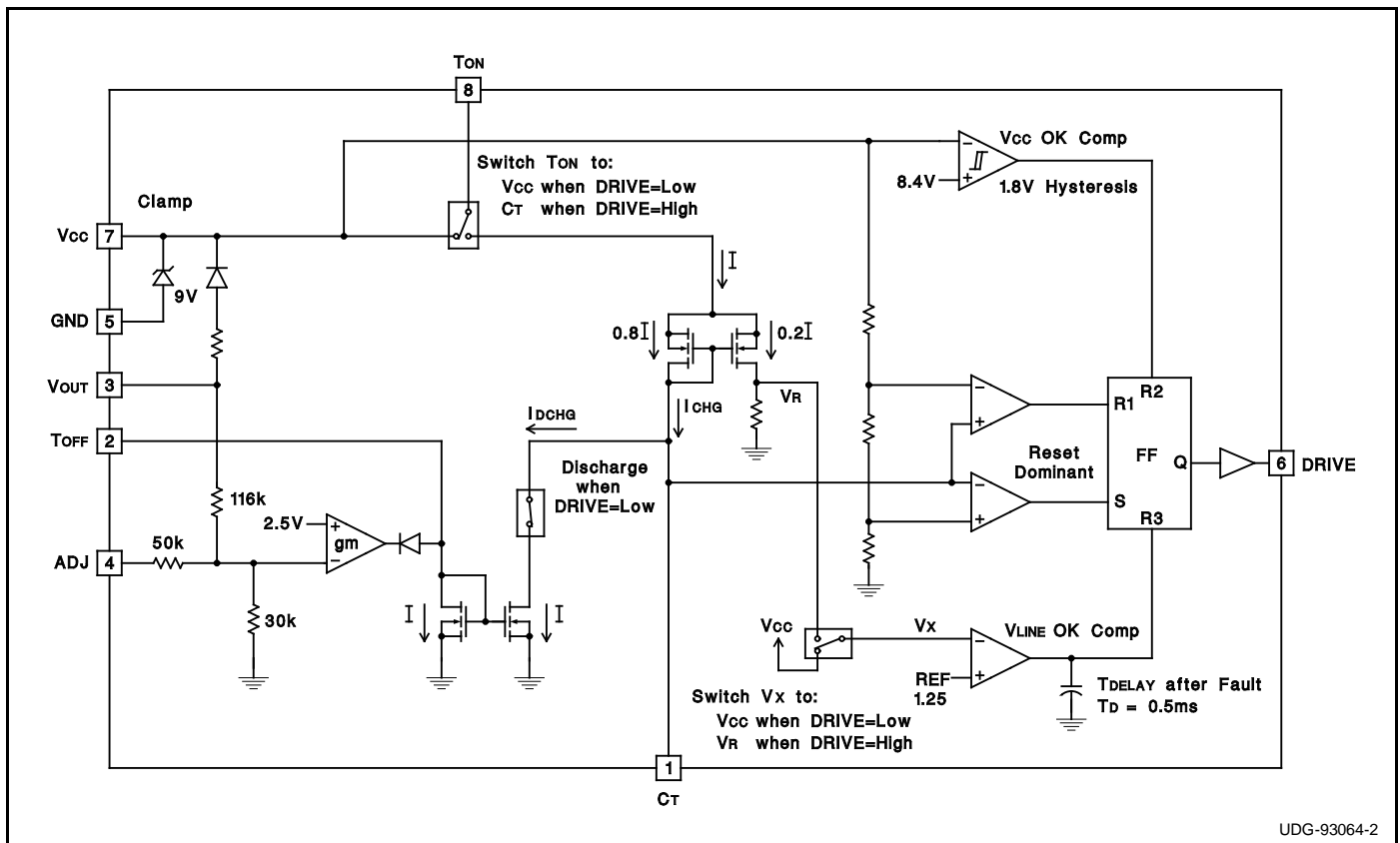

UDG-93064-2

TYPICAL WAVEFORMS

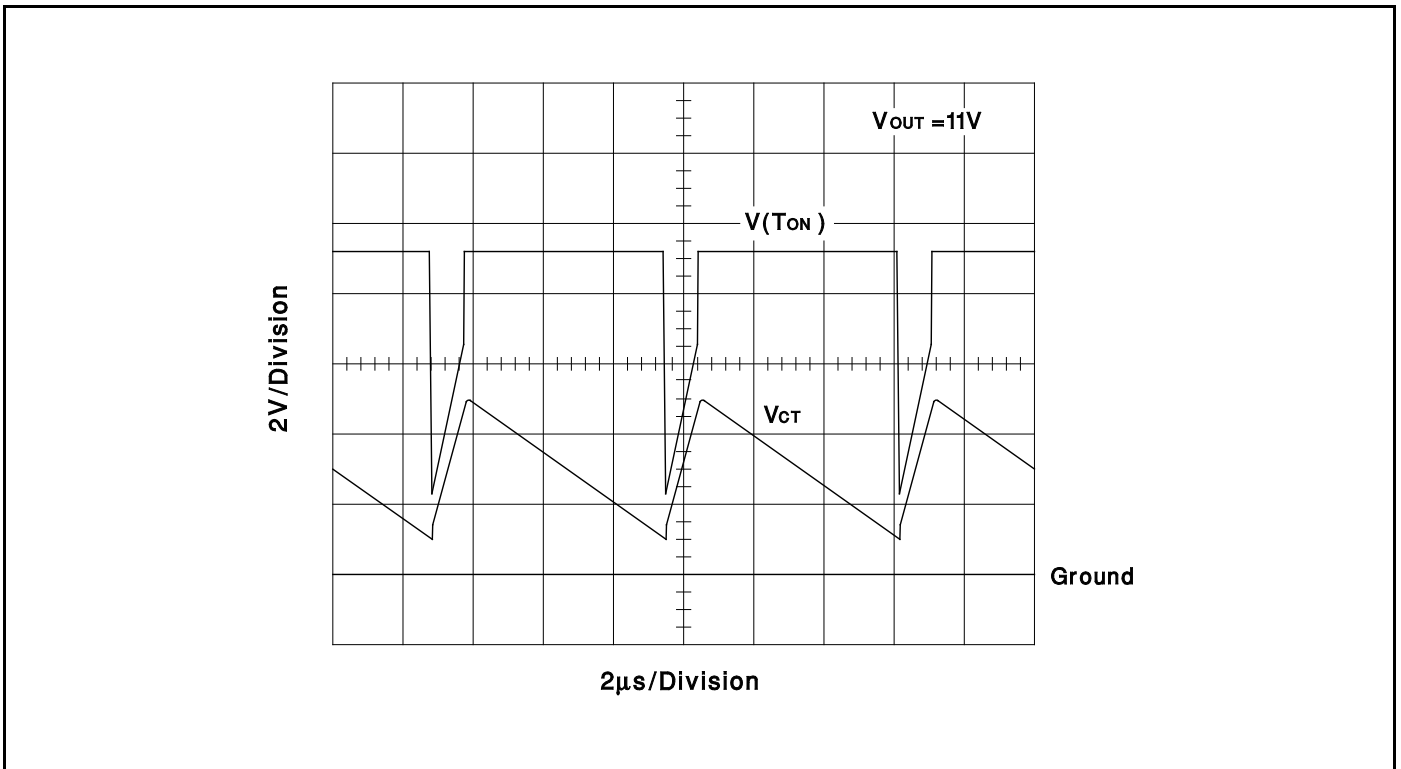
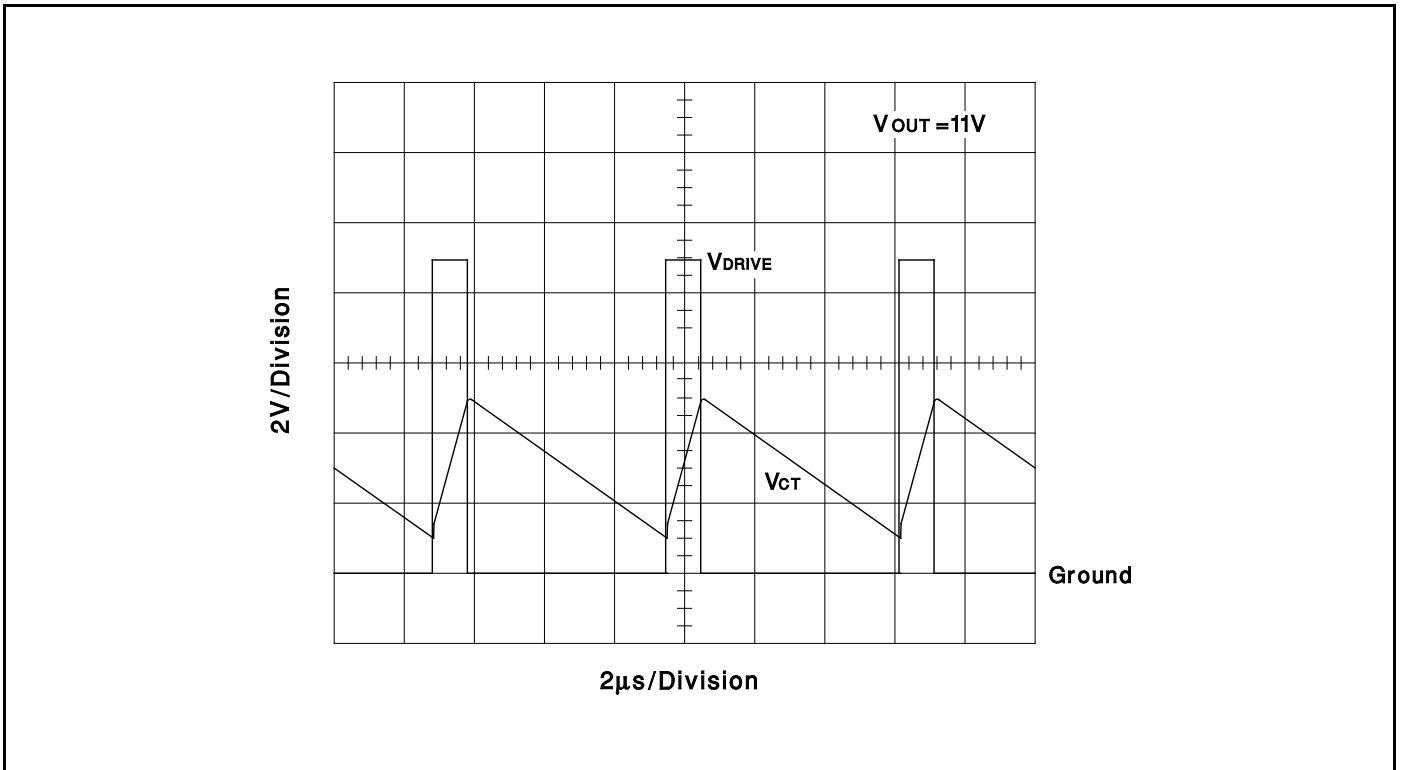

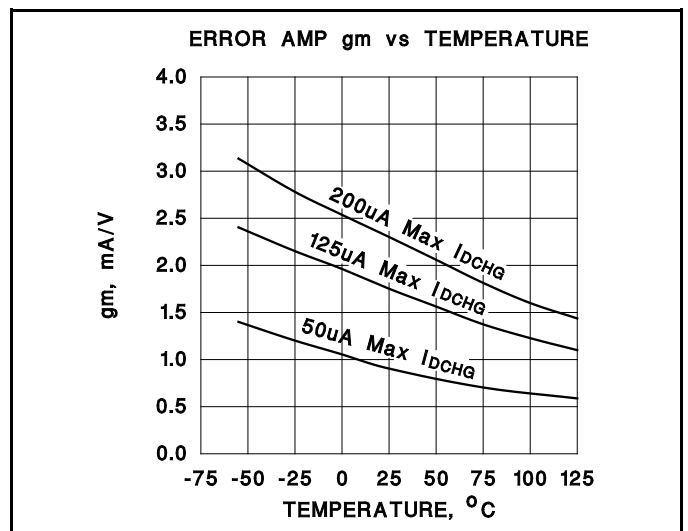
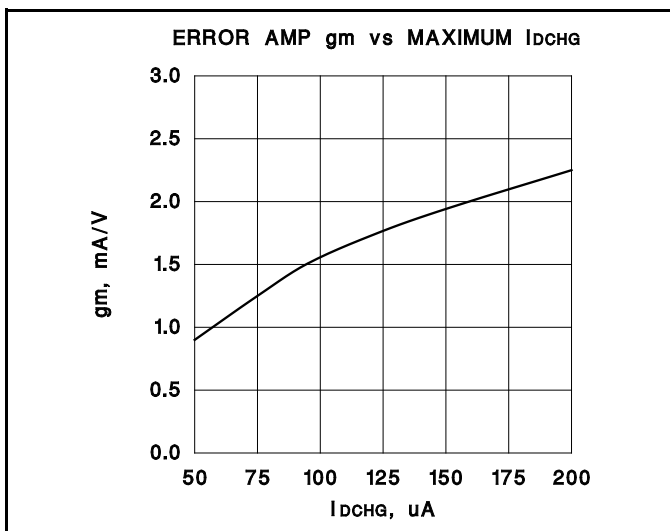
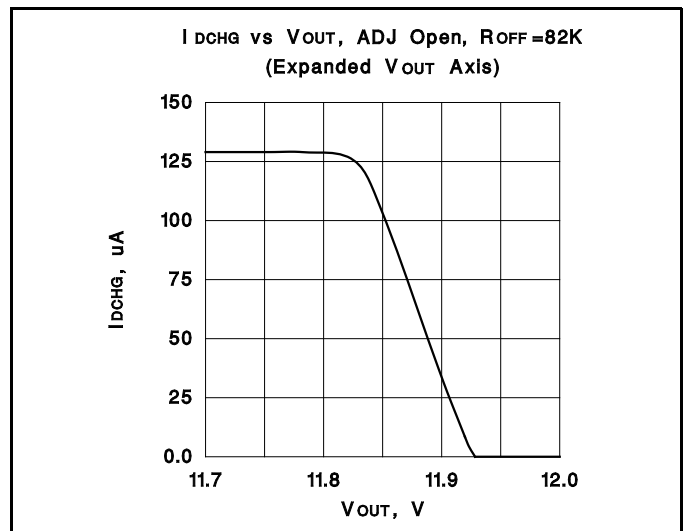
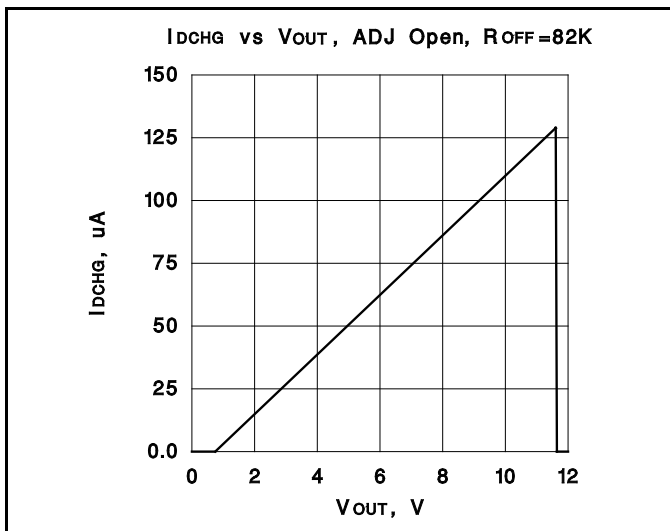
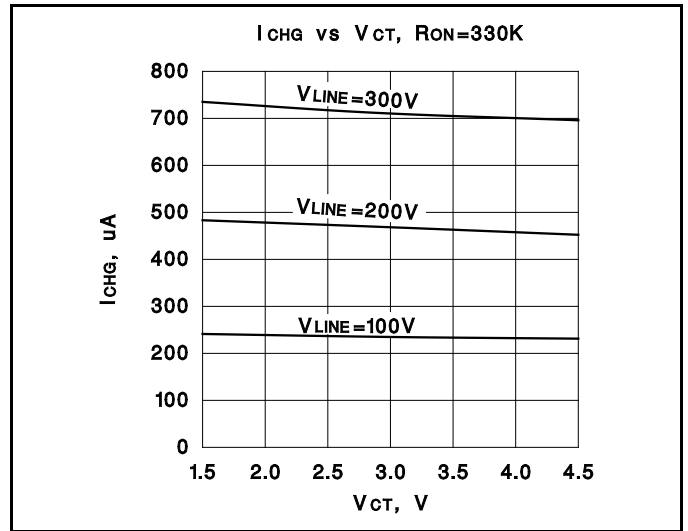
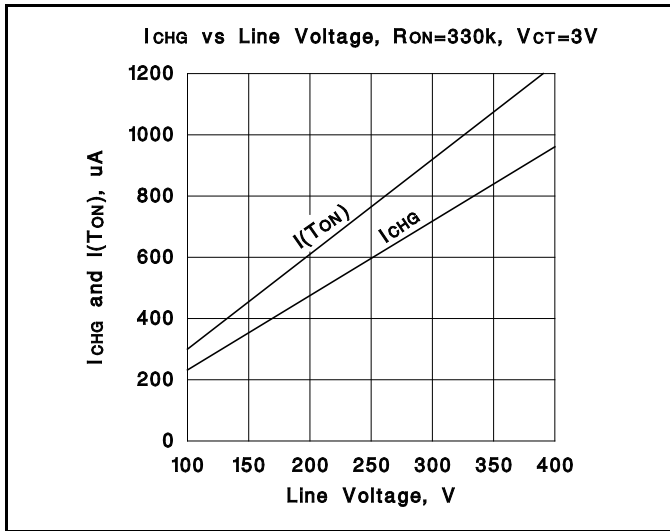

**PACKAGING INFORMATION**

Orderable Device	Status (1)	Package Type	Package Drawing	Pins	Package Qty	Eco Plan (2)	Lead/Ball Finish	MSL Peak Temp (3)	Op Temp (°C)	Top-Side Markings (4)	Samples
UCC2889D	ACTIVE	SOIC	D	8	75	Green (RoHS & no Sb/Br)	CU NIPDAU	Level-2-260C-1 YEAR	-40 to 85	UCC2889	<a href="#">Samples</a>
UCC2889DG4	ACTIVE	SOIC	D	8	75	Green (RoHS & no Sb/Br)	CU NIPDAU	Level-2-260C-1 YEAR	-40 to 85	UCC2889	<a href="#">Samples</a>
UCC2889DTR	ACTIVE	SOIC	D	8	2500	Green (RoHS & no Sb/Br)	CU NIPDAU	Level-2-260C-1 YEAR	-40 to 85	UCC2889	<a href="#">Samples</a>
UCC2889DTR/81361G4	PREVIEW	SOIC	D	8		TBD	Call TI	Call TI	-40 to 85	UCC2889	
UCC2889DTRG4	ACTIVE	SOIC	D	8	2500	Green (RoHS & no Sb/Br)	CU NIPDAU	Level-2-260C-1 YEAR	-40 to 85	UCC2889	<a href="#">Samples</a>
UCC2889N	ACTIVE	PDIP	P	8	50	Green (RoHS & no Sb/Br)	CU NIPDAU	N / A for Pkg Type	-40 to 85	UCC2889N	<a href="#">Samples</a>
UCC2889NG4	ACTIVE	PDIP	P	8	50	Green (RoHS & no Sb/Br)	CU NIPDAU	N / A for Pkg Type	-40 to 85	UCC2889N	<a href="#">Samples</a>
UCC3889D	ACTIVE	SOIC	D	8	75	Green (RoHS & no Sb/Br)	CU NIPDAU	Level-2-260C-1 YEAR	0 to 70	UCC3889	<a href="#">Samples</a>
UCC3889DG4	ACTIVE	SOIC	D	8	75	Green (RoHS & no Sb/Br)	CU NIPDAU	Level-2-260C-1 YEAR	0 to 70	UCC3889	<a href="#">Samples</a>
UCC3889DTR	ACTIVE	SOIC	D	8	2500	Green (RoHS & no Sb/Br)	CU NIPDAU	Level-2-260C-1 YEAR	0 to 70	UCC3889	<a href="#">Samples</a>
UCC3889DTRG4	ACTIVE	SOIC	D	8	2500	Green (RoHS & no Sb/Br)	CU NIPDAU	Level-2-260C-1 YEAR	0 to 70	UCC3889	<a href="#">Samples</a>
UCC3889N	ACTIVE	PDIP	P	8	50	Green (RoHS & no Sb/Br)	CU NIPDAU	N / A for Pkg Type	0 to 70	UCC3889N	<a href="#">Samples</a>
UCC3889NG4	ACTIVE	PDIP	P	8	50	Green (RoHS & no Sb/Br)	CU NIPDAU	N / A for Pkg Type	0 to 70	UCC3889N	<a href="#">Samples</a>

(1) The marketing status values are defined as follows:

**ACTIVE:** Product device recommended for new designs.

**LIFEBUY:** TI has announced that the device will be discontinued, and a lifetime-buy period is in effect.

**NRND:** Not recommended for new designs. Device is in production to support existing customers, but TI does not recommend using this part in a new design.

**PREVIEW:** Device has been announced but is not in production. Samples may or may not be available.

**OBSOLETE:** TI has discontinued the production of the device.

(2) Eco Plan - The planned eco-friendly classification: Pb-Free (RoHS), Pb-Free (RoHS Exempt), or Green (RoHS & no Sb/Br) - please check <http://www.ti.com/productcontent> for the latest availability information and additional product content details.

---

**TBD:** The Pb-Free/Green conversion plan has not been defined.

**Pb-Free (RoHS):** TI's terms "Lead-Free" or "Pb-Free" mean semiconductor products that are compatible with the current RoHS requirements for all 6 substances, including the requirement that lead not exceed 0.1% by weight in homogeneous materials. Where designed to be soldered at high temperatures, TI Pb-Free products are suitable for use in specified lead-free processes.

**Pb-Free (RoHS Exempt):** This component has a RoHS exemption for either 1) lead-based flip-chip solder bumps used between the die and package, or 2) lead-based die adhesive used between the die and leadframe. The component is otherwise considered Pb-Free (RoHS compatible) as defined above.

**Green (RoHS & no Sb/Br):** TI defines "Green" to mean Pb-Free (RoHS compatible), and free of Bromine (Br) and Antimony (Sb) based flame retardants (Br or Sb do not exceed 0.1% by weight in homogeneous material)

<sup>(3)</sup> MSL, Peak Temp. -- The Moisture Sensitivity Level rating according to the JEDEC industry standard classifications, and peak solder temperature.

<sup>(4)</sup> Only one of markings shown within the brackets will appear on the physical device.

**Important Information and Disclaimer:** The information provided on this page represents TI's knowledge and belief as of the date that it is provided. TI bases its knowledge and belief on information provided by third parties, and makes no representation or warranty as to the accuracy of such information. Efforts are underway to better integrate information from third parties. TI has taken and continues to take reasonable steps to provide representative and accurate information but may not have conducted destructive testing or chemical analysis on incoming materials and chemicals. TI and TI suppliers consider certain information to be proprietary, and thus CAS numbers and other limited information may not be available for release.

In no event shall TI's liability arising out of such information exceed the total purchase price of the TI part(s) at issue in this document sold by TI to Customer on an annual basis.



## TAPE AND REEL INFORMATION



### QUADRANT ASSIGNMENTS FOR PIN 1 ORIENTATION IN TAPE



\*All dimensions are nominal

Device	Package Type	Package Drawing	Pins	SPQ	Reel Diameter (mm)	Reel Width W1 (mm)	A0 (mm)	B0 (mm)	K0 (mm)	P1 (mm)	W (mm)	Pin1 Quadrant
UCC2889DTR	SOIC	D	8	2500	330.0	12.4	6.4	5.2	2.1	8.0	12.0	Q1
UCC3889DTR	SOIC	D	8	2500	330.0	12.4	6.4	5.2	2.1	8.0	12.0	Q1

**TAPE AND REEL BOX DIMENSIONS**



\*All dimensions are nominal

Device	Package Type	Package Drawing	Pins	SPQ	Length (mm)	Width (mm)	Height (mm)
UCC2889DTR	SOIC	D	8	2500	367.0	367.0	35.0
UCC3889DTR	SOIC	D	8	2500	367.0	367.0	35.0

P (R-PDIP-T8)

PLASTIC DUAL-IN-LINE PACKAGE





4040082/E 04/2010

- NOTES:
- A. All linear dimensions are in inches (millimeters).
  - B. This drawing is subject to change without notice.
  - C. Falls within JEDEC MS-001 variation BA.

D (R-PDSO-G8)

PLASTIC SMALL OUTLINE



- NOTES:
- A. All linear dimensions are in inches (millimeters).
  - B. This drawing is subject to change without notice.
  -  Body length does not include mold flash, protrusions, or gate burrs. Mold flash, protrusions, or gate burrs shall not exceed 0.006 (0,15) each side.
  -  Body width does not include interlead flash. Interlead flash shall not exceed 0.017 (0,43) each side.
  - E. Reference JEDEC MS-012 variation AA.

D (R-PDSO-G8)

PLASTIC SMALL OUTLINE



4211283-2/E 08/12

- NOTES:
- A. All linear dimensions are in millimeters.
  - B. This drawing is subject to change without notice.
  - C. Publication IPC-7351 is recommended for alternate designs.
  - D. Laser cutting apertures with trapezoidal walls and also rounding corners will offer better paste release. Customers should contact their board assembly site for stencil design recommendations. Refer to IPC-7525 for other stencil recommendations.
  - E. Customers should contact their board fabrication site for solder mask tolerances between and around signal pads.

## IMPORTANT NOTICE

Texas Instruments Incorporated and its subsidiaries (TI) reserve the right to make corrections, enhancements, improvements and other changes to its semiconductor products and services per JESD46, latest issue, and to discontinue any product or service per JESD48, latest issue. Buyers should obtain the latest relevant information before placing orders and should verify that such information is current and complete. All semiconductor products (also referred to herein as "components") are sold subject to TI's terms and conditions of sale supplied at the time of order acknowledgment.

TI warrants performance of its components to the specifications applicable at the time of sale, in accordance with the warranty in TI's terms and conditions of sale of semiconductor products. Testing and other quality control techniques are used to the extent TI deems necessary to support this warranty. Except where mandated by applicable law, testing of all parameters of each component is not necessarily performed.

TI assumes no liability for applications assistance or the design of Buyers' products. Buyers are responsible for their products and applications using TI components. To minimize the risks associated with Buyers' products and applications, Buyers should provide adequate design and operating safeguards.

TI does not warrant or represent that any license, either express or implied, is granted under any patent right, copyright, mask work right, or other intellectual property right relating to any combination, machine, or process in which TI components or services are used. Information published by TI regarding third-party products or services does not constitute a license to use such products or services or a warranty or endorsement thereof. Use of such information may require a license from a third party under the patents or other intellectual property of the third party, or a license from TI under the patents or other intellectual property of TI.

Reproduction of significant portions of TI information in TI data books or data sheets is permissible only if reproduction is without alteration and is accompanied by all associated warranties, conditions, limitations, and notices. TI is not responsible or liable for such altered documentation. Information of third parties may be subject to additional restrictions.

Resale of TI components or services with statements different from or beyond the parameters stated by TI for that component or service voids all express and any implied warranties for the associated TI component or service and is an unfair and deceptive business practice. TI is not responsible or liable for any such statements.

Buyer acknowledges and agrees that it is solely responsible for compliance with all legal, regulatory and safety-related requirements concerning its products, and any use of TI components in its applications, notwithstanding any applications-related information or support that may be provided by TI. Buyer represents and agrees that it has all the necessary expertise to create and implement safeguards which anticipate dangerous consequences of failures, monitor failures and their consequences, lessen the likelihood of failures that might cause harm and take appropriate remedial actions. Buyer will fully indemnify TI and its representatives against any damages arising out of the use of any TI components in safety-critical applications.

In some cases, TI components may be promoted specifically to facilitate safety-related applications. With such components, TI's goal is to help enable customers to design and create their own end-product solutions that meet applicable functional safety standards and requirements. Nonetheless, such components are subject to these terms.

No TI components are authorized for use in FDA Class III (or similar life-critical medical equipment) unless authorized officers of the parties have executed a special agreement specifically governing such use.

Only those TI components which TI has specifically designated as military grade or "enhanced plastic" are designed and intended for use in military/aerospace applications or environments. Buyer acknowledges and agrees that any military or aerospace use of TI components which have **not** been so designated is solely at the Buyer's risk, and that Buyer is solely responsible for compliance with all legal and regulatory requirements in connection with such use.

TI has specifically designated certain components as meeting ISO/TS16949 requirements, mainly for automotive use. In any case of use of non-designated products, TI will not be responsible for any failure to meet ISO/TS16949.

### Products

Audio	<a href="http://www.ti.com/audio">www.ti.com/audio</a>
Amplifiers	<a href="http://amplifier.ti.com">amplifier.ti.com</a>
Data Converters	<a href="http://dataconverter.ti.com">dataconverter.ti.com</a>
DLP® Products	<a href="http://www.dlp.com">www.dlp.com</a>
DSP	<a href="http://dsp.ti.com">dsp.ti.com</a>
Clocks and Timers	<a href="http://www.ti.com/clocks">www.ti.com/clocks</a>
Interface	<a href="http://interface.ti.com">interface.ti.com</a>
Logic	<a href="http://logic.ti.com">logic.ti.com</a>
Power Mgmt	<a href="http://power.ti.com">power.ti.com</a>
Microcontrollers	<a href="http://microcontroller.ti.com">microcontroller.ti.com</a>
RFID	<a href="http://www.ti-rfid.com">www.ti-rfid.com</a>
OMAP Applications Processors	<a href="http://www.ti.com/omap">www.ti.com/omap</a>
Wireless Connectivity	<a href="http://www.ti.com/wirelessconnectivity">www.ti.com/wirelessconnectivity</a>

### Applications

Automotive and Transportation	<a href="http://www.ti.com/automotive">www.ti.com/automotive</a>
Communications and Telecom	<a href="http://www.ti.com/communications">www.ti.com/communications</a>
Computers and Peripherals	<a href="http://www.ti.com/computers">www.ti.com/computers</a>
Consumer Electronics	<a href="http://www.ti.com/consumer-apps">www.ti.com/consumer-apps</a>
Energy and Lighting	<a href="http://www.ti.com/energy">www.ti.com/energy</a>
Industrial	<a href="http://www.ti.com/industrial">www.ti.com/industrial</a>
Medical	<a href="http://www.ti.com/medical">www.ti.com/medical</a>
Security	<a href="http://www.ti.com/security">www.ti.com/security</a>
Space, Avionics and Defense	<a href="http://www.ti.com/space-avionics-defense">www.ti.com/space-avionics-defense</a>
Video and Imaging	<a href="http://www.ti.com/video">www.ti.com/video</a>

### TI E2E Community

[e2e.ti.com](http://e2e.ti.com)