

Control/GF/Current & Voltage Relays & Pilot Devices

Contents

Control/GF/Current & Voltage Relays & Pilot Devices

Pushbuttons, Selector Switches & Indicating Lights

M22, C22, 10250T, E34, HT800, E30 Series
Pilot Devices Overview 32.1-1

Ground Fault Relays and Monitors

Type D64 Series—Digital Ground Fault Relay System 32.2-1
EGF Series Ground Fault Sensors 32.2-8

Current Sensing and Monitoring

D65C Series—Overview 32.2-11

Voltage Monitoring Relays

D65 Series—Voltage Monitoring Relays 32.3-1
D65 Series—Voltage Band Relays 32.3-3
D85 Series—Alternating Relays 32.3-4

General Purpose Plug-In Relays

Selection Guide 32.4-1
Multi-Pole Relays 32.4-4
Solid-State Relays 32.4-5

Counting and Timing Relays

Universal TR Series 32.5-1
1/32 DIN LCD—Timers 32.5-1
Durant E42DIR Series 32.5-4
Durant E42A24M Series 32.5-4
Panel Meters—Eclipse Series 32.5-4

Specifications

See Eaton's *Product Specification Guide*, available on CD or on the Web.

CSI Format:	1995	2010
	Sections 16902, 16903	Sections 26 29 05, 26 09 11



Control Relays, Pushbuttons and Selector Switches

This page intentionally left blank.

M22*M22 Pushbuttons***General Description**

Eaton's M22 industrial heavy-duty pushbutton line offers a wide array of functional, attractive and ergonomically designed illuminated and non-illuminated pushbuttons, selector switches, push-pulls, alternate action and twist-to-release operators. The complete illuminated line is only offered in LED light units to ensure high-quality brightness and up to 100,000 hours of LED illumination. M22 operators are available with either a silver or a black colored bezel. The space-saving modular construction of the M22 line makes on-the-job assembly fast and simplifies the stocking of both components and complete devices.

Features

- Field-convertible pushbuttons and mushroom operators from maintained to momentary status
- Field-convertible selector switches from momentary to maintained operation and vice versa
- LED offering only for all illuminated operators
- Laser-engraved pushbuttons, lenses and enclosures
- Heavy-duty construction with a minimum of IP66 and UL NEMA® Type 4X/13 on front of panel operators. Many operators even carry IP67 and IP69K, for the toughest applications
- Silver or black colored nylon bezels
- Snap-lock contact blocks and light units for front or base mounting
- Notched hole mounting with anti-rotation tab and central nut mounting on each operator
- Over 5 million mechanical operations and 1.6 million electrical (reference specification sheet)
- Direct opening action normally closed contacts
- Unique and innovative offerings, such as four-way pushbuttons and USB/RJ45 bulkhead interfaces
- Screw or spring-cage terminals

C22*C22 Pushbuttons***General Description**

Eaton's C22 compact pushbutton line offers an industry-leading array of functional, attractive and ergonomically designed "all-in-one" illuminated and non-illuminated pushbuttons, selector switches, emergency stops and indicating lights. The complete illuminated line is only offered in LED light units to ensure high-quality brightness and up to 100,000 hours of LED illumination. C22 operators are available with either a silver or black bezel, and share the exact same front of the panel look and feel as Eaton's M22 line. The C22's compact, "all-in-one" design with the contact block(s) and operators integral provides the user a simple solution.

Features

- Field-convertible maintained pushbuttons from maintained to momentary
- Field-convertible selector switches from momentary to maintained operation and vice versa
- 100% LED offering for all illuminated operators improves brightness quality and gives up to 100,000 hours of operation
- Laser-engraved pushbuttons and lenses allow for high-quality, wear-resistant markings
- Heavy-duty construction with a minimum of IP65 and UL NEMA Type 4X/13 on front of panel operators. Many operators even carry IP67 and IP69K, for the toughest applications
- Silver or black colored nylon bezels
- Notched hole mounting with anti-rotation tab and central nut mounting on each operator saves installation time and prevents operator rotation
- Pushbuttons (momentary) rated for 5 million mechanical operations and selector switches (non-keyed) rated for 1 million mechanical operations
- Plastic construction is corrosion-resistant

10250T*10250T Pushbuttons***General Description**

10250T pushbuttons provide superior sealing and set the industry standard. They offer the most extensive line of operator styles. Primary industries include: aggregate, automotive, construction vehicles, forest products, industrial equipment, material handling, metal forming, metal stamping, petrochemical, and pulp and paper.

Features

- 30.5 mm diameter design
- Heavy-duty die-cast metal construction
- Corrosion-resistant
- Enclosed silver contacts with reliability nibs
- Diaphragm seals with drainage holes
- Grounding nibs on the operator casing
- Chrome nickel finish
- Includes specialty operators
- Self-grounding operators
- Contact blocks with finger-proof shrouds optional

Benefits

- Reliability nibs improve contact reliability even under dry circuit and fine dust conditions
- Drainage holes prevent buildup of liquid inside the operator that can prevent operation in freezing environments
- Grounding nibs bit through paint and other coatings to provide secure ground

E34



E34 Pushbuttons

General Description

E34 Series pushbutton line features the same rugged construction of the 10250T pushbutton, but has an additional two-layer solid thermosetting epoxy coating. This coating provides a consistent, corrosion-resistant surface that has well surpassed industry standards and testing. Primary industries include: automotive, chemical plants, food and beverage, and food service equipment, industrial equipment, pulp and paper, and waste/water treatment plants.

Features and Benefits

- 30.5 mm diameter design
- Die-cast metal construction
- Two-layer 100% solid thermosetting cathodic epoxy coating
- Highly corrosion-resistant
- Black matte epoxy coated finish
- Integral ground terminal screw-on operators
- FDA approved for sanitary chemical-resistance requirements
- Rated Class 1 Division 2 for hazardous locations
- Construction and extra coating provide superior sealing

HT800



HT800 Pushbuttons

General Description

Eaton's HT800 Series is a family of 30.5 mm pushbutton devices that includes momentary, illuminated and mushroomhead pushbuttons, selector switches, indicating lights and push-pull switches. The HT800 devices have a familiar appearance found in most industrial applications and are suitable for replacement of several other manufacturers' 30.5 mm pushbutton devices.

Features and Benefits

- Anodized aluminum mounting rings
- Watertight double V-gasket seals
- Extended height bulbs
- Transparent housing contact blocks
- Gold-plated contacts (on low voltage contact block)
- Reliability ridge on movable contact
- Contact blocks can be mounted in left/right or top/bottom positions
- Standard NC contact opens before NO contact closes (break before make operation)
- Bright and long-lasting LED indicating lights in six colors
- Field-convertible maintained selector switches—from two- to three-position and vice versa
- Field-selectable knob/lever mounting positions—at any 22.5° increment
- Corrosion-resistant NEMA 4X finish
- Watertight and oiltight NEMA 4, 13 ingress protection
- Easily identifiable NO (white) or NC (black) contact blocks
- Contact blocks with finger-proof shrouds optional

E30



E30 Pushbuttons

General Description

Eaton's Type E30 industrial pushbutton, indicating light and selector switch line features a wide selection of square, multi-function operators that conveniently mount in a standard 30.5 mm (1-13/64 inches) diameter panel hole. Up to six input and indicating functions can be grouped into a single operating head, saving valuable panel space. Attractive square operator styling, coupled with custom legending of colored buttons and lenses, and many special function accessories, makes E30 components ideally suited for use on control consoles and for a variety of industrial OEM applications.







Features

Type E30 control units consist of a basic operator with one or more buttons and lenses, and contact block selection dependent on the specific operator configuration.

- **Pushbutton operators** will accommodate up to four single depth stackable contact blocks behind each operating button, up to eight circuits maximum
- **Indicating lights** are supplied complete with either a transformer light unit up to 600 Vac supply line voltage or full voltage light unit up to 120 Vac/Vdc supply line voltage
- **Combination pushbutton with indicating light operators** are supplied complete with a transformer or full voltage unit. Contact blocks must be ordered separately, up to four circuits maximum
- **Selector switches** in non-illuminated, illuminated and key versions are supplied as complete assembled units including Type E22 light units and contact blocks, up to four circuits maximum

Pushbutton Application Matrix

Table 32.1-1. Pushbutton Application Matrix

Product Series	Characteristics	Primary Industries	Application Conditions				
			Indoors Watertight and Oil Tight	Outdoors Watertight and UV-Resistant	Subject to Freezing	High-Pressure Washdown	Sanitary-Chemical Treatment
 <p>M22 22.5 mm IP67/69k NEMA 4X/13 Engineered plastic construction Modular design</p>	<p>Food and beverage Food service equipment Industrial equipment Packaging Printing machinery Waste/water treatment plants</p>	Yes	Yes	(-25°C)	Most operators IP 67/69k	No	No
 <p>C22 22.5 mm IP67/69k NEMA 4X/13 Engineered plastic construction Compact (monoblock) design</p>	<p>Food and beverage Food service equipment Industrial equipment Packaging Printing machinery</p>	Yes	Yes	(-25°C)	Most operators IP 67/69k	No	No
 <p>10250T 30.5 mm diameter Chrome nickel finish Corrosion-resistant (NEMA 4X) Die-cast metal construction Includes specialty operators Most extensive line of operator styles Self-grounding operators Superior sealing</p>	<p>Aggregate Automotive Construction vehicles Forest products Industrial equipment Material handling Metal forming Metal stamping Petrochemical Pulp and paper</p>	Yes	Yes	Yes Boots required	Yes Uses controlled compression gaskets	No	Yes Use with factory-sealed contact blocks
 <p>E34 30.5 mm diameter Black matte epoxy coated finish Die-cast metal construction FDA approved Highly corrosion-resistant (NEMA 4X++) Integral ground terminal Screw-on operator Superior sealing</p>	<p>Automotive Chemical plants Food and beverage Food service equipment Industrial equipment Pulp and paper Waste/water treatment plants</p>	Yes	Not recommended for use outdoors if appearance is important. Corrosion resistance remains unchanged, but black color will fade.	Yes Boots required	Yes Uses controlled compression gaskets	Yes Complies with FDA3-A sanitary standards	Yes Use with factory-sealed contact blocks
 <p>HT800 30.5 mm diameter Corrosion-resistant (NEMA 4X) Die-cast metal construction Limited number of operator types Low profile design Standard industry appearance Supplied complete w/grounding kits</p>	<p>Automotive Food service equipment Industrial equipment Material handling Packaging Printing machinery</p>	Yes	Yes	No	Yes	No	No
 <p>E30 30.5 mm diameter Compact design Corrosion-resistant (NEMA 4X) Multi-function operators Square shaped</p>	<p>Aggregate Airline services Asphalt paving Building automation Power utilities Printing machinery</p>	Yes	Yes	Not recommended		No	No

Note: For more information, see Volume 7—Motor Controls, Logic and Connectivity, CA08100008E, Tab 37.

This page intentionally left blank.

D64R Series—Digital Ground Fault Relays



D64RPB100—Digital Ground Fault Relay with Built-In Current Sensor or Zero-Sequence CT

General Description

The D64R digital ground fault relays are microprocessor-based and replace the previous generation of analog-based devices.

Microprocessor-based D64R ground fault relays combine more selectable features into a single model, which makes easier model selection and reduces spares inventory requirements.

These devices are designed to provide reliable detection of ground fault conditions on three-phase AC resistance grounded or solidly grounded electrical distribution systems.

Application Description

D64R ground fault relays feature adjustable trip settings for both trip current and trip time. This allows the user to set the ground fault trip current just above the “charging” current of the system. This prevents nuisance tripping and provides meaningful protection of additional ground fault leakage currents.

Every system has a “charging” current that can cause nuisance tripping if the trip current is set too low. The “charging” current is caused by the capacitance-to-ground effect of phase conductors in a system and will vary depending on:

- Overall length of the cables
- Types of loads
- Quality of the insulation on the phase conductors
- Surrounding equipment grounding, cable trays, junction boxes, and the like
- Type and size of transformer

A “rule-of-thumb” for systems 600V and lower: the “charging” current is 0.5A per 1000 kVA of transformer capacity.

Features

Standard Models

- Built-in current sensor (zero sequence CT)
- Run and trip indicating LEDs
- Built-in harmonic filtering for variable frequency drives or standard 50/60 Hz applications
- DIN rail or panel mounting
- Rugged epoxy encapsulated construction
- Pull-apart terminal block connectors
- Form “Z” (four terminal) NO and NC output contacts, 5A at 250 Vac
- Pulsed (trip) auto reset mode

The pulsed (trip) auto reset mode is designed for applications where the output relay is operating a shunt trip device. The D64R relay resets automatically, 3 seconds after the ground fault current is interrupted by the tripping action of the circuit breaker. This opens the output contact wired to the shunt trip coil and prevents damage to the internal mechanism of the circuit breaker in the event that the operator tries to reset the circuit breaker.

- Suitable for use on 600V systems—may be applied on higher voltages by using separate CTs with power conductors insulated for the system voltage
- Built-in test circuitry—no external power or additional wiring is necessary—tests trip time and current settings
- Communications port (standard RJ-10 jack) for connection to optional remote display (D64D1) door-mounted units (on D64RPB100 models only)
- Fail-safe selectable mode (on D64RPB100 models only)

In the fail-safe mode, the relay is energized when control voltage is applied and will trip when either:

- Ground fault trip is detected
- There is a loss of control power

Service Protection Models

- Service protection models require C311CT 10,000:1 ratio CTs
- Trip current range of 50 to 1200A
- Green LED indicates “Power On”
- Circuit breaker toggle position indicates “Normal” or “Tripped” condition
- Form C (three terminal) NO-NC output contacts, 3A at 250 Vac
- Frequency response range of 40–200 Hz
- Zone interlocking feature with green LED to indicate “Grading Input Active” and DIP switch array for zone grading backup delay and block signal override (on D64RPBH15 model only)
- Test button to invoke test at 20A trip current—tests external CT, electronics and circuit breaker trip
- Fail-safe selectable mode (see above for description)
- Inhibit selectable mode—this allows the relay to differentiate between normal ground fault trip levels and short-circuit conditions

The trip inhibit function is useful when the relay is being used to trip a contactor or motor starter on a solidly grounded system. Under a bolted fault condition, the relay would trip and could cause the contactor or motor starter to interrupt the high fault current with harmful results. By inhibiting the trip, the ground fault relay will not trip on bolted faults and will allow the upstream protective device to clear the fault instead.

- Through-the-door or rear panel mounting

D64R Series—Digital Ground Fault Relays

Technical Data

Table 32.2-1. Technical Data Specifications

Control Power (Volts)	Frequency Response (Hz)	Trip Current Range		Trip Time Delay Range		Built-In Current Sensor	External Current Transformer		Test/Reset Provision		Catalog Number
		Min.	Max.	Min.	Max.		Required	Ratio	Pushbutton on Cover	Remote	
24–240 Vac/Vdc non-isolated	45–450 Hz	30 mA	6A	20 ms	500 ms	1.1"	Optional	500:1	No	Pushbutton	D64RP18
24–240 Vac/Vdc isolated	45–450 Hz	30 mA	9A	20 ms	5 sec	2.0"	Optional	500:1	Yes	Pushbutton or RJ-11 communications port	D64RPB100
		3A	900A				Required	500:5			
		30A	9000A				Required	5000:5			
120 Vac	45–200 Hz	50A	1200A	35 ms	1 sec	None	Required	10000:1	Yes	Pushbutton	D64RPBH13
120 Vac	40–200 Hz	50A	1200A	35 ms	1 sec	None	Required	10000:1	Yes	Pushbutton	D64RPBH15 ①

① With zone interlocking feature.

Standards and Certifications

- UL® 1053:
 - Ground Fault Sensing and Relaying Equipment, Class 1 (UL File No. E195341)
- CSA® C22.2 No. 144-M91:
 - Ground Fault Circuit Interrupters (CSA File No. 700103)
- CE mark—Declaration of Conformity
- IEC 60755:
 - General Requirements for residual current operated protective devices
- EN 50081-1:
 - Electromagnetic compatibility (radiated emission), “household” directive

D64R ground fault relays are UL listed as Class 1 devices designed to protect electrical equipment against extensive damage from arcing ground faults.

Factory Options

- Other ranges of trip currents and times
- Fixed trip current and times
- Other control voltages
- Custom packaging for volume OEM requirements
- Separate outputs for alarming vs trip
- Relays for neutral grounding resistance monitoring
- Relays for ground fault detection on DC power systems
- Other sizes of current transformers



Sample D64R Ground Fault Relay in Custom Packaging for OEM

Accessories



C311CT9

Zero Sequence Current Transformers

- A complete size range of zero sequence CTs designed specifically for use with D64R relays provide excellent coupling to the monitored circuit. This means accurate ground fault leakage current detection over the full setting range of the relay with no saturation
- Built-in back-to-back zeners across the output terminals of all 500:1 and 10,000:1 CTs provide personnel safety should the secondary circuit be opened
- Rectangular split core CTs make retro-fitting easy
- All CTs are epoxy potted, panel mounted and come with either secondary screw terminals or threaded studs
- The core is very high grade silicon iron to give superior coupling characteristics and to withstand high shock and vibration
- All CTs are 600V class. They may be used on higher voltage circuits provided that power conductors are insulated for the system voltage

Table 32.2-2. Zero Sequence Current Transformers for D64RP18 and D64RPB100 Relays ①②③

Description/Window Size	Ratio 500:1 CTs ④
	Catalog Number

Toroidal Zero Sequence CT

1.10 inch (27.9 mm)	C311CT8
1.80 inch (45.7 mm)	C311CT1
2.50 inch (63.5 mm)	C311CT9
3.50 inch (88.9 mm)	C311CT2
5.70 inch (144.8 mm)	C311CT5
9.50 inch (241.3 mm)	C311CT6

Split Core (Rectangular/Square) Zero Sequence CT

5.90 x 6.70 inch (149.9 x 170.2 mm)	C311CT3
4.00 x 13.80 inch (101.6 x 350.5 mm)	C311CT4
11.80 x 11.80 inch (299.7 x 299.7 mm)	C311CT7

- ① D64RP18 relays use 500:1 ratio CTs if needed.
- ② D64RPB100 relays can use 500:1 ratio CTs when needed for 30 mA–9A, 500:5 ratio for 3–900A and 5000:5 ratio for 30–9000A trip current ranges.
- ③ For 500:5 or 5000:5 ratio CTs, select any commercially available 5A secondary CT with the same ratio.
- ④ The maximum allowable continuous current through CTs is 1000A.

Table 32.2-3. Zero Sequence Current Transformers for D64RPBH13 and D64RPBH15 Relays

Description	Ratio 10,000:1 CTs ⑤
	Catalog Number

Toroidal Zero Sequence CT

Window— 2.5 inch (65 mm)	C311CT11
5.0 inch (127 mm)	C311CT10
5.7 inch (144 mm)	C311CT12
9.5 inch (240 mm)	C311CT13

- ⑤ The maximum allowable continuous current through 10,000:1 ratio CTs is 10,000A.

D64D1 Digital Display Unit



D64D1

General Description

The D64D1 digital display unit is connected to the D64RPB100 by up to 30 feet (10m) of standard four-wire telephone type cable. It is supplied with door mounting hardware. It provides the following remote indications and functions:

- Continuous reading of actual ground fault current, employing auto ranging
- Display of the pre-trip ground fault current, after a trip has occurred (flashing display)
- Display of the trip current setting, after a Test Trip has been activated
- Green RUN LED, Red TRIP LED
- TEST and RESET pushbuttons. The RESET button must be held pressed before the TEST is pressed to invoke the test procedure. The function of this button can be enabled/disabled by inserting the interconnecting cable from the D64RPB100 relay into one of two sockets, TEST ON or TEST OFF, on the right side of the display

- Pushing VERIFY pushbutton shows if D64RPB100 tripped due to a ground fault prior to loss of its control voltage—red TRIP LED lights, or if there was no ground fault trip—green RUN LED lights. This indication will remain available for at least 10 hours
- The Numerical LCD window displays actual ground fault current in amperes. When a 5000:5 ratio interposing CT is used, all displayed values are to be interpreted as kA rather than amperes

Table 32.2-4. Remote Display and Indicator Units for D64RPB100

Description	Catalog Number
Remote digital display with Numerical LCD, RUN and TRIP LEDs, TEST, RESET and VERIFY Pushbuttons: c/w 3 ft (1m) of cable	D64D1

D64R Series, Digital Ground Fault Relays Connection Diagrams

Typical Connection Diagrams

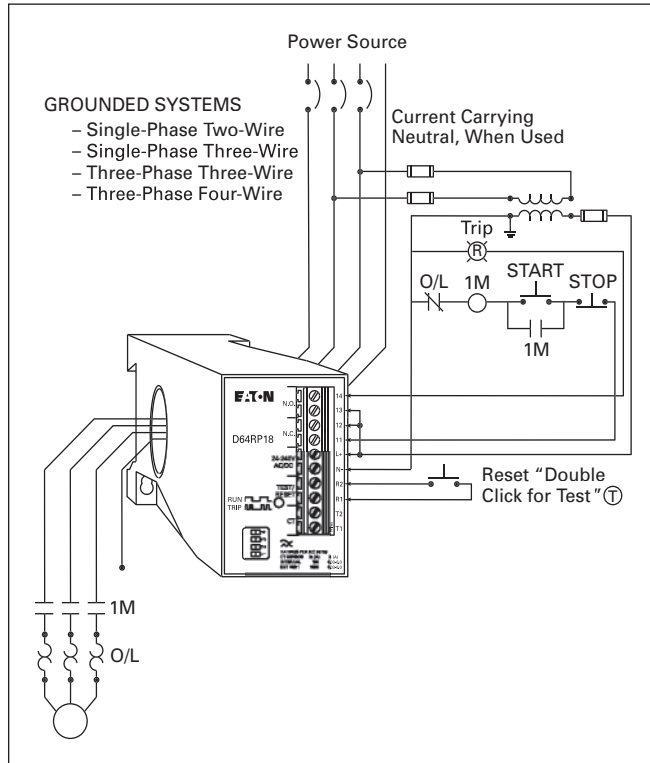

Figure 32.2-1. Typical Field Connection of D64RP18 Using Built-In Current Transformer

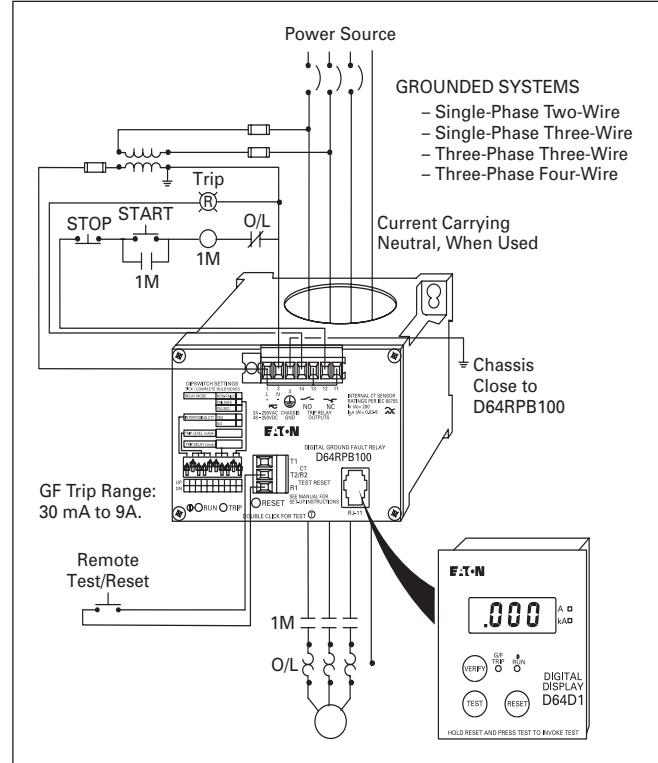

Figure 32.2-3. Typical Field Connection of D64RPB100 Using Built-In Current Transformer and Remote Test/Reset

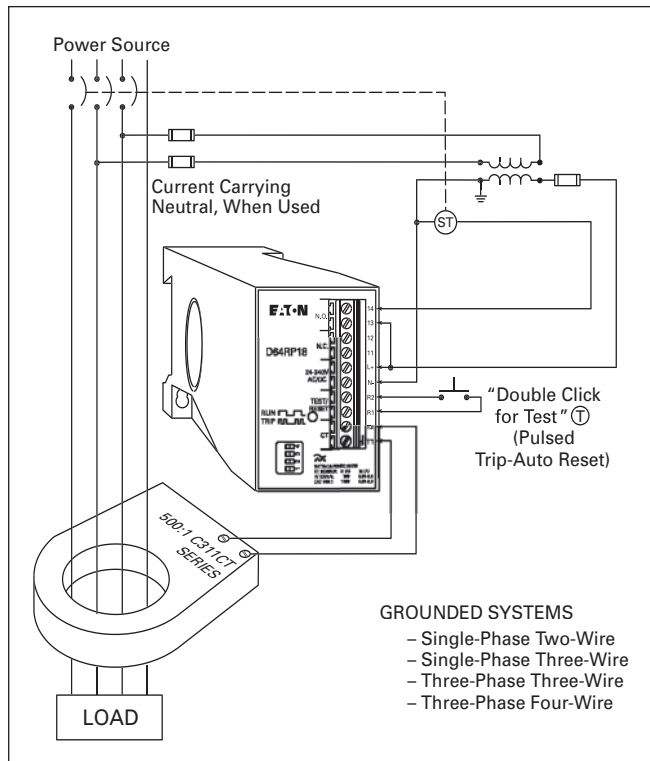

Figure 32.2-2. Typical Field Connection of D64RP18 with External 500:1 Current Transformer and Pulsed Trip-Auto Reset

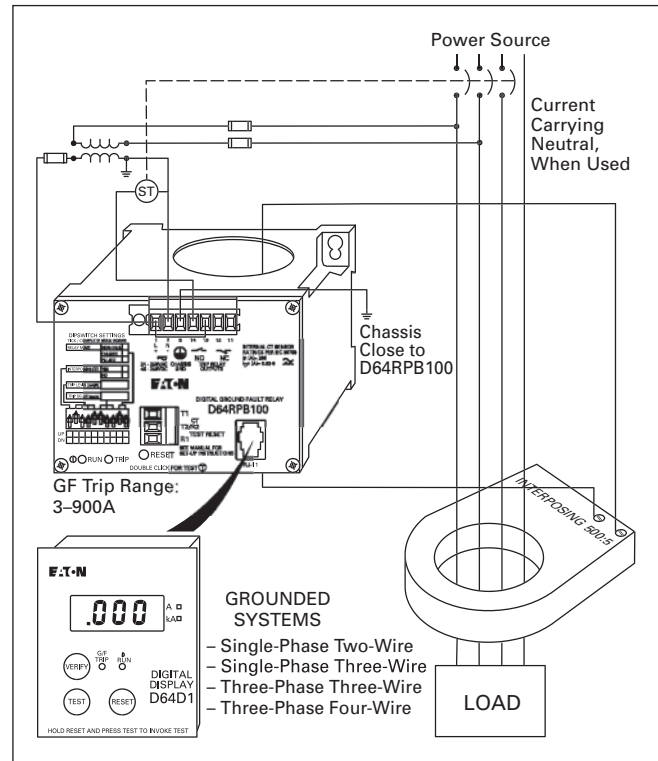

Figure 32.2-4. Typical Field Connection of D64RPB100 with Interposing 500:5 Current Transformer, Pulsed Trip-Auto Reset for Shunt Trip Breaker

D64R Series, Digital Ground Fault Relays Connection Diagrams

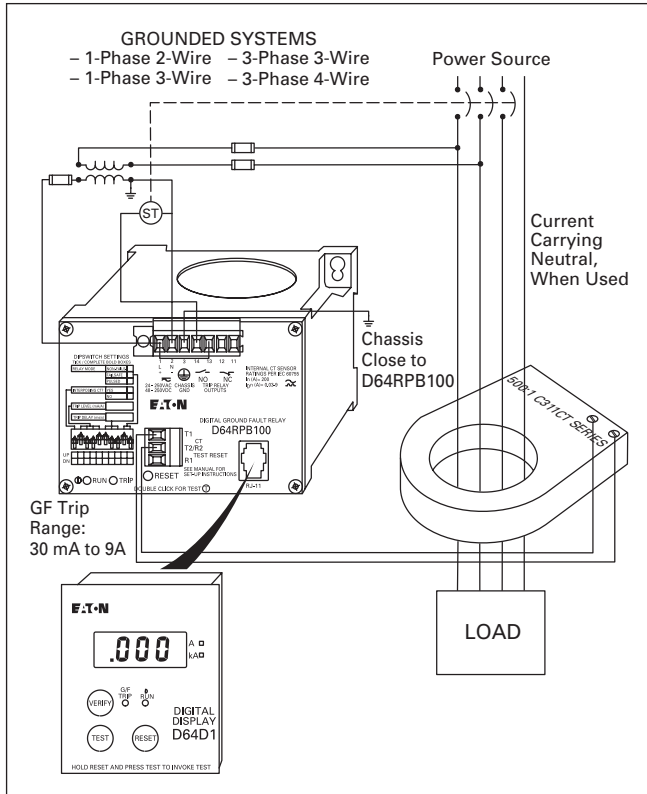

Figure 32.2-5. Typical Field Connection of D64RPB100 with External 500:1 Current Transformer (C311CT Series) Pulsed Trip-Auto Reset for Shunt Trip Breaker

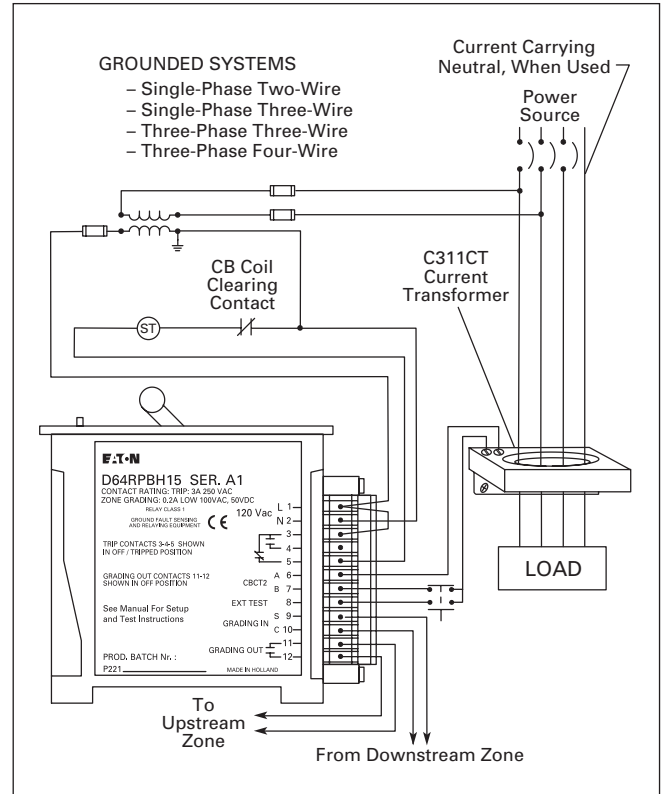

Figure 32.2-7. D64RPBH15 Typical Field Connection with Zone Selective Interlocking

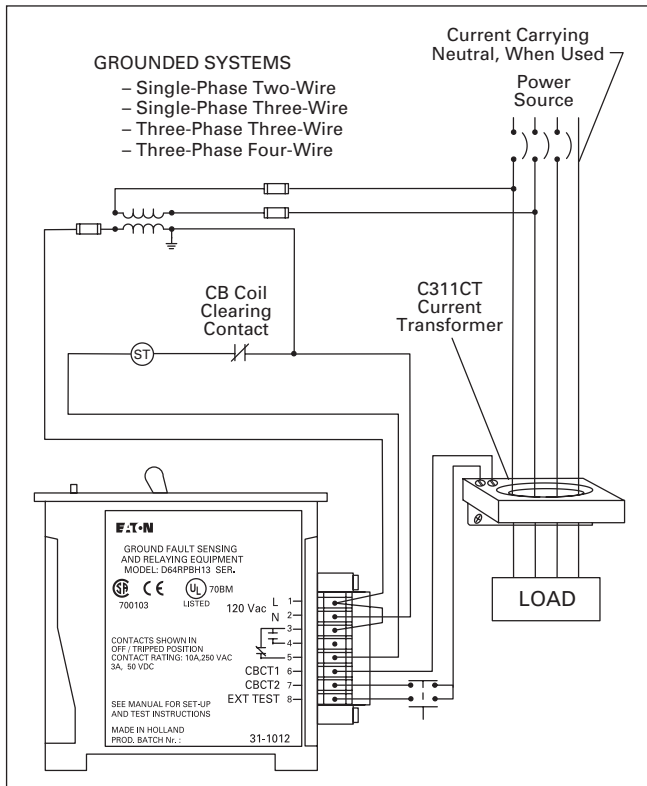

Figure 32.2-6. D64RPBH13 Typical Field Connections

D64R Series, Digital Ground Fault Relays Dimensions

Dimensions

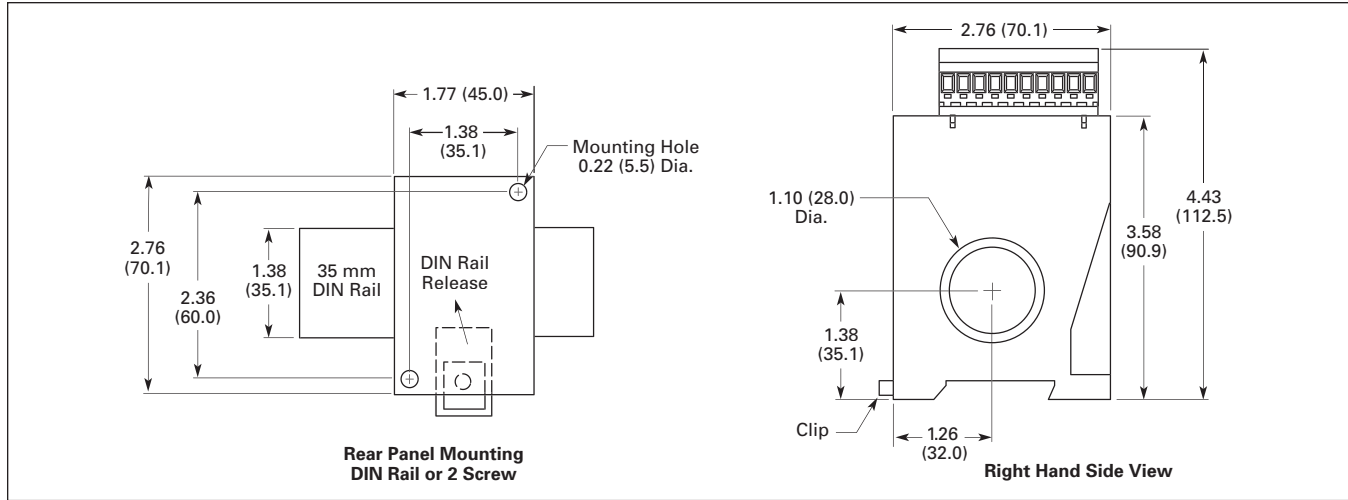

Figure 32.2-8. D64RP18—Approximate Dimensions in Inches (mm)

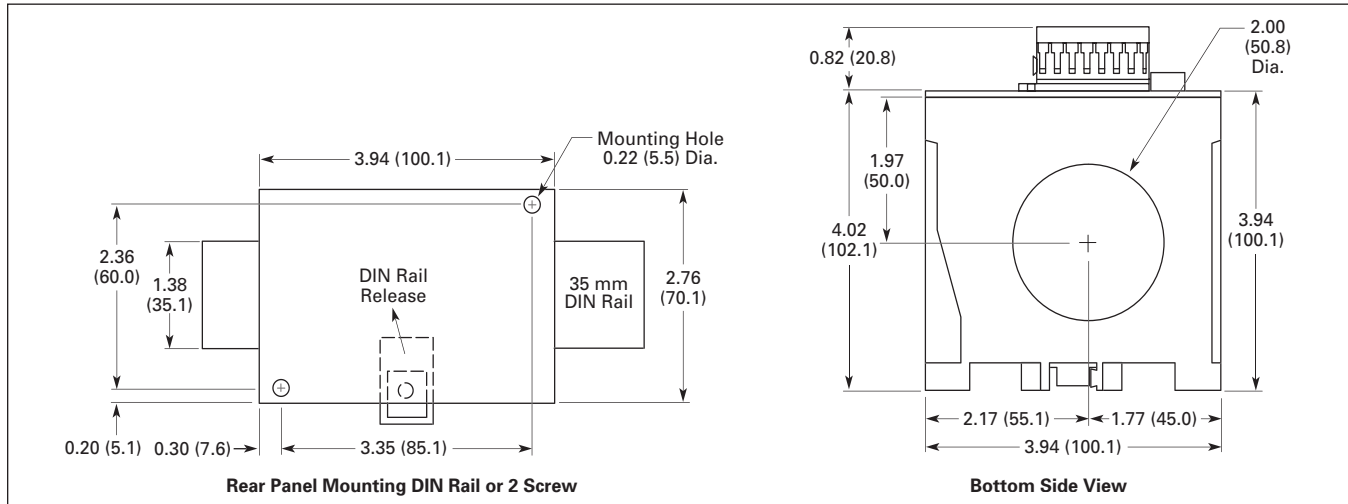

Figure 32.2-9. D64RPB100—Approximate Dimensions in Inches (mm)

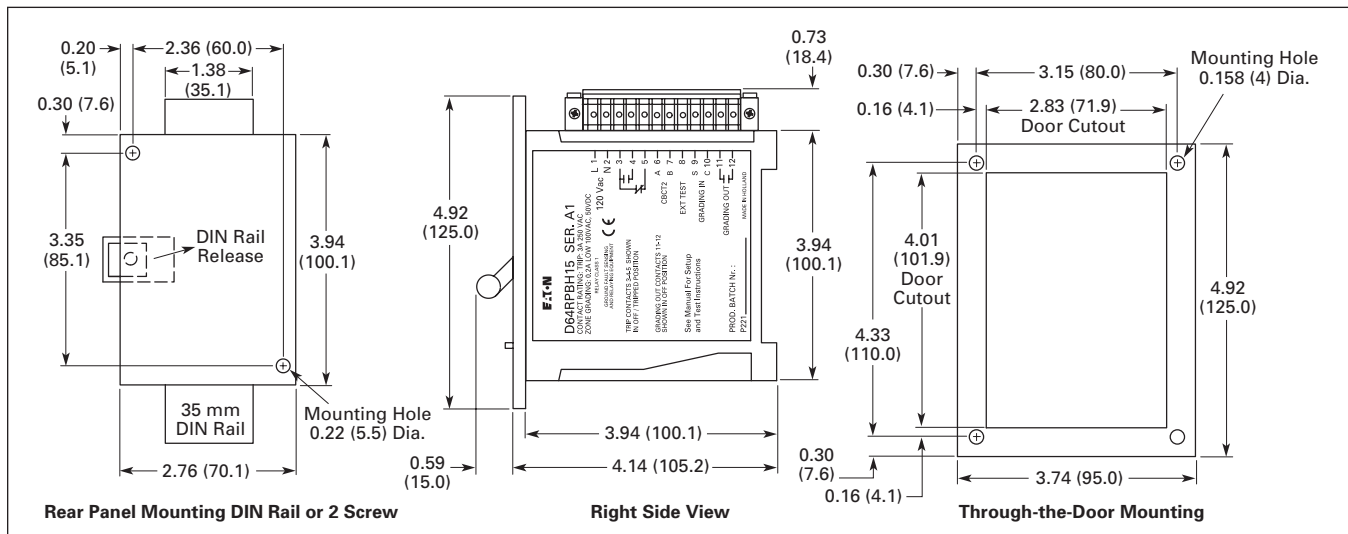

Figure 32.2-10. D64RPBH13 and D64RPBH15—Approximate Dimensions in Inches (mm)

D64R Series—Digital Ground Fault Relays and C311CT Series Dimensions

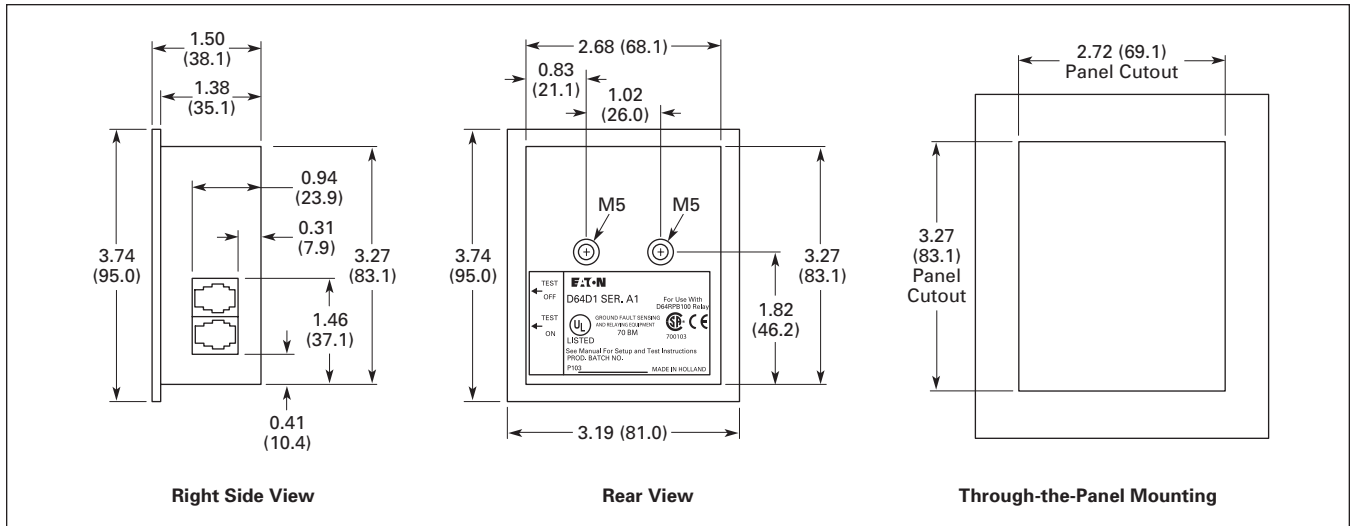

Figure 32.2-11. D64D1 Digital Display Unit and D64D2 Remote Indicator Unit—Approximate Dimensions in Inches (mm)

Table 32.2-5. C311CT Series Dimensions

Figure	Approximate Dimensions in Inches (mm)			Mounting		F	G	H	Catalog Number
	Wide A	High B	Deep C	D	E				
A	3.35 (85.1)	3.35 (85.1)	1.57 (40.0)	0.98 (24.9)	0.39 (10.0)	1.81 (46.0)	—	—	C311CT1
B	7.30 (185.4)	5.50 (139.7)	1.20 (30.5)	6.42 (163.1)	0.59 (15.0)	3.54 (89.9)	—	0.89 (22.6)	C311CT2
C	13.58 (345.0)	8.75 (222.3)	1.57 (40.0)	12.80 (325.1)	0.59 (15.0)	6.70 (170.2)	5.90 (149.9)	0.89 (22.6)	C311CT3
C	20.87 (530.1)	7.87 (200.0)	1.57 (40.0)	20.08 (510.0)	0.59 (15.0)	13.78 (350.0)	3.94 (100.0)	0.89 (22.6)	C311CT4
B	10.12 (257.0)	8.27 (210.1)	1.46 (37.1)	9.33 (237.0)	0.59 (15.0)	5.70 (144.8)	—	0.89 (22.6)	C311CT5
B	13.86 (352.0)	11.89 (302.0)	1.46 (37.1)	13.07 (332.0)	0.59 (15.0)	9.45 (240.0)	—	0.89 (22.6)	C311CT6
A	2.17 (55.1)	2.56 (65.0)	2.20 (55.8)	0.98 (24.9)	0.39 (10.0)	1.10 (27.9)	—	—	C311CT8
B	6.68 (169.7)	4.84 (123.0)	1.18 (30.0)	5.78 (146.8)	0.59 (15.0)	2.56 (65.0)	—	0.89 (22.6)	C311CT9
B	10.12 (257.0)	8.27 (210.1)	1.85 (47.0)	9.33 (237.0)	0.59 (15.0)	5.00 (127.0)	—	0.89 (22.6)	C311CT10
B	6.68 (169.7)	4.84 (123.0)	1.18 (30.0)	5.78 (146.8)	0.59 (15.0)	2.56 (65.0)	—	0.89 (22.6)	C311CT11
B	10.12 (257.0)	8.27 (210.1)	1.85 (47.0)	9.33 (237.0)	0.59 (15.0)	5.70 (144.8)	—	0.89 (22.6)	C311CT12
B	13.86 (352.0)	11.89 (302.0)	1.85 (47.0)	13.07 (332.0)	0.59 (15.0)	9.45 (240.0)	—	0.89 (22.6)	C311CT13

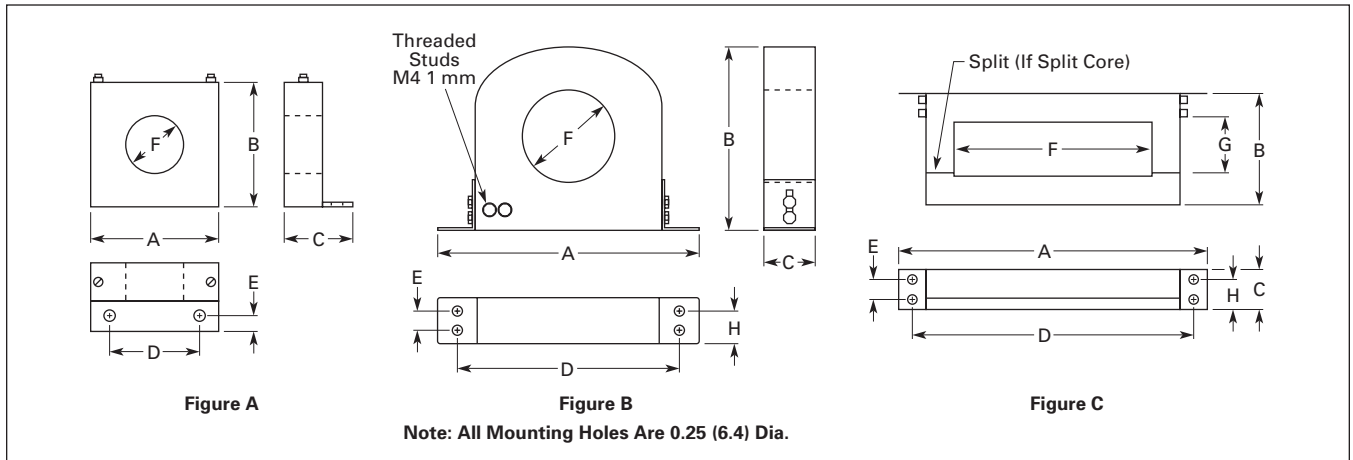

Figure 32.2-12. C311CT Series Approximate Dimensions in Inches (mm)

EGF Series Ground Fault Sensors

EGF Series Ground Fault
CurrentWatch Current Sensors

The CurrentWatch™ EGF Series from Eaton's electrical business is a family of ground fault (earth leakage) sensors. Ground fault sensors help protect people, products and processes from damage caused by ground fault conditions by monitoring all current-carrying conductors in grounded single- and three-phase delta or wye systems. The EGF Series is available with either solid-state or mechanical relay outputs.

The EGF Series with solid-state outputs offers the benefit of reliable, long-lasting solid-state switches. Solid-state design provides unlimited switch operating life, superior resistance to shock and vibration, zero off-state leakage, high switch speeds and high input-output isolation. Solid-state outputs have solid-core housings with screw terminals.

The EGF Series with mechanical relay outputs are available in solid-core housings with a choice of NO or NC SPST latching relays and a SPDT Form C relay with auto-reset. All mechanical models can be ordered with a fixed set point or with a "tri-set" option, which provides three factory-set, field-adjustable set points.

Approvals

- UL recognized

Product Features

- **Broad range of options to meet application needs**—NO or NC, solid-state or mechanical relays, normally energized or normally de-energized contacts
- **Set point options maximize ease-of-use and application flexibility**—Field-selectable 5, 10 or 30 mA set points on the EGF "Tri-set" models make user adjustments fast, sure and convenient
- **Compatible with standard equipment**—Application on single- and three-phase systems, ideal for use with shunt trip breakers, and magnetically isolated from monitored circuit and control power
- **Agency approved**—UL and CE certified, accepted worldwide

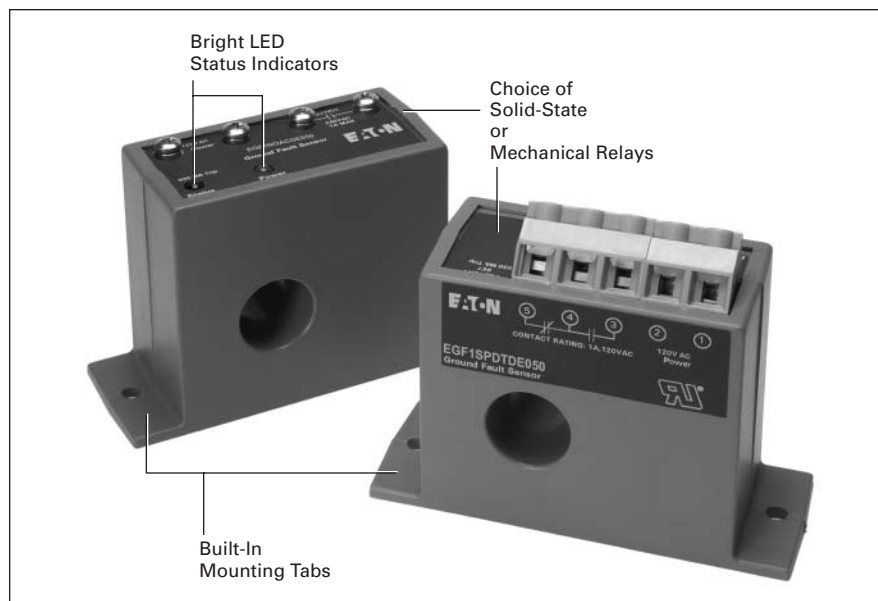

Figure 32.2-13. Ground Fault Sensors with Solid-State or Mechanical Relay Outputs

Typical Applications

- **Personnel protection (typically 5 mA)**—Detects sensitive ground fault conditions, which could cause injury to people, and functions as a sensor and alarm trigger when applied as an input to an overall ground fault protection system
- **Equipment protection (typically 10 or 30 mA)**—For applications where personnel protection is not the primary concern, higher set point capability helps eliminate nuisance tripping while still providing adequate ground fault detection to protect machine electronics
- **Regulatory**—Meets requirements as stipulated by governmental and industrial regulatory groups for ground fault sensing

"Zero Sequence" Operating Principle

In three-phase delta and wye systems, under normal conditions, current in the "hot" leg of a two-wire load is equal in magnitude, but opposite in sign to the current in a neutral leg. As a result, the electromagnetic fields surrounding these two conductors cancel, producing a "zero sequence current." As soon as current leaks to ground (fault condition), the two currents become imbalanced and a net magnetic field results. The CurrentWatch EGF Series sensors monitor this field and trips the contacts when the leakage rises above the set point.

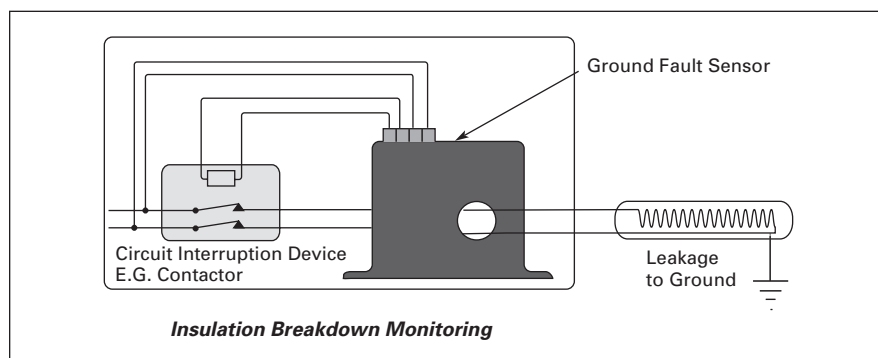

Figure 32.2-14. Example Application—CurrentWatch EGF Series

EGF Series Ground Fault Sensors

Table 32.2-6. Wiring Diagrams—CurrentWatch EGF Series

Models	Wiring Diagrams
<p>Solid-state output models</p>	
<p>Mechanical relay output models</p>	<p>Latching Models</p> <p>External Reset Switch</p> <p>1 2 3 4 5 6</p> <p>Power Output Power Status</p> <p>Jumper Location of Tri-set Models</p> <p>Auto Reset Models</p> <p>1 2 3 4 5 6</p> <p>Power Output Power Status</p> <p>Jumper Location of Tri-set Models</p>

EGF Series Ground Fault Sensors

Table 32.2-7. Specifications—CurrentWatch EGF Series

Description	Solid-State Output Models	Mechanical Relay Output Models
Power supply	120 Vac (55–110% of nominal voltage) 24 Vac/dc (±20%)	
Output contact type	Isolated dry contact	Mechanical relay
Output rating (switching current and switching voltage)	AC output switching models: 1A at 240 Vac DC output switching models: 0.15A at 30 Vdc	Auto reset models: SPDT Relay 1A at 120 Vac 2A at 30 Vdc Latching Models: SPST Relay 1A at 120 Vac 2A at 30 Vdc
Off-state leakage	NO models: <10 µA NC models: <2.5 mA	None
Response time	200 ms at 5% above trip point 60 ms at 50% above trip point 15 ms at 500% above trip point	
Frequency range	50–400 Hz (monitored circuit)	
Loading	2 VA max.	
Isolation voltage	5000 Vac (tested)	
Sensing aperture	0.74 in (19 mm) dia.	
LED indicator	Green LED for Power On status; Red LED for Contact status	
Housing	UL94 V0 flammability rated	
Environmental	Operating temperature: –4 to 122°F (–20 to 50°C) Humidity: 0–95% RH, noncondensing	
Approvals	UL 1053, Class 1 recognized, CE	

Product Family Overview



Current Monitoring Relays

General Description

The D65C Series Current Monitoring Relays monitor AC single-phase currents for over- or undercurrent conditions in three current ranges: 0.1–1A, 0.5–5A and 1–10A. An external current transformer may be used to extend the range of the product. A separate 24V or 120 Vac input (supply) voltage is required to power the unit. All versions are available in a compact plug-in case using industry standard 8- or 11-pin octal sockets.

Standards and Certifications



When used with accompanying Eaton socket.



Product Family Selection

Standard

Fixed time delay on both pickup and dropout current settings.

Table 32.2-8. D65C Product Family Selection—Standard Function

Series	Pickup		Dropout		Page
	Setting	Time Delay	Setting	Time Delay	
D65CE	Adjustable (across monitored range)	Fixed 100 ms ①	Fixed (-5% pickup)	Fixed 100 ms ①	32.2-12
D65CEK			Adjustable (50–95% pickup)		

① Fixed time delay eliminates nuisance tripping due to short current surges or drops.

Overcurrent

Adjustable time delay on pickup and fixed time delay on dropout current settings.

Table 32.2-9. D65C Product Family Selection—Overcurrent Function

Series	Pickup		Dropout		Page
	Setting	Time Delay	Setting	Time Delay	
D65CH	Adjustable (across monitored range)	0.1–10 sec adjustable	Fixed (-5% pickup)	Fixed 100 ms ②	32.2-13
D65CHK			Adjustable (50–95% pickup)		

② Fixed time delay eliminates nuisance tripping due to short current surges or drops.

Undercurrent

Fixed time delay on pickup and adjustable time delay on dropout current settings.

Table 32.2-10. D65C Product Family Selection—Undercurrent Function

Series	Pickup		Dropout		Page
	Setting	Time Delay	Setting	Time Delay	
D65CL	Fixed (+5% dropout)	Fixed 100 ms ③	Adjustable (across monitored range)	0.1–10 sec adjustable	32.2-14

③ Fixed time delay eliminates nuisance tripping due to short current surges or drops.

Typical Installations

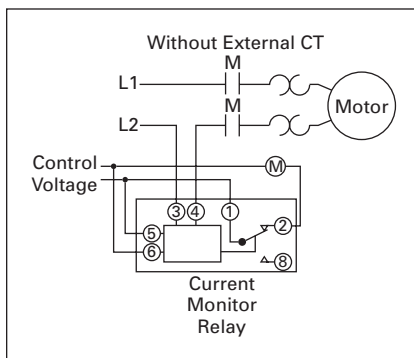

Figure 32.2-15. Typical Installation without External CT

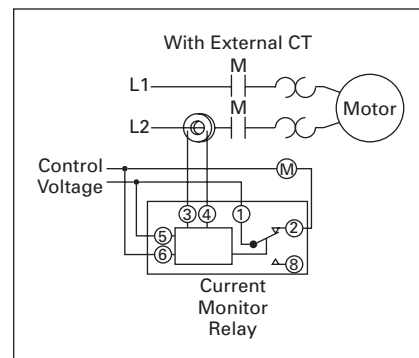

Figure 32.2-16. Typical Installation with External CT

D65CE Series—Standard Current Monitors

Standard Current Monitors



D65CE Series Standard Current Monitors

General Description

The D65CE Series standard current monitors are used to detect either an overcurrent or undercurrent condition. The pickup current setting is user-adjustable within three ranges (0.1–1A), (0.5–5A) or (1–1A). The range can be extended beyond 10A with the use of an external current transformer. Choose between a fixed dropout current setting at 95% of the selected pickup setting or an adjustable dropout setting of 50–95% of the selected pickup setting. The relay will energize when the monitored AC current is above the pickup setting, and will de-energize when the monitored AC current is below the dropout setting. The time delay on both pickup and dropout is fixed at 100 ms. Adjustable time delays are available with the D65CH and D65CL Series.

Features

- Monitors AC single-phase currents
- Three separate current monitoring ranges covering 0.1–10A
- External CT can be used to extend ranges
- Adjustable pickup setting with either fixed or adjustable dropout setting
- LED indicates output relay status
- Choice of compact 8-pin SPDT or 11-pin DPDT plug-in case
- 10A output contacts

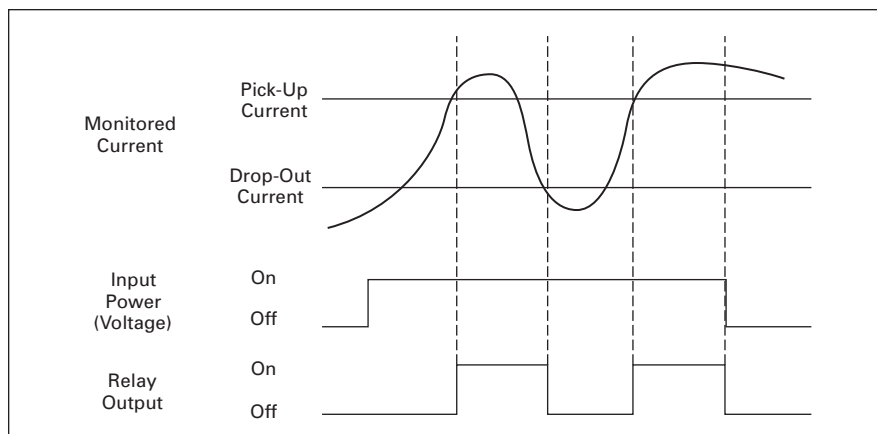

Figure 32.2-17. Standard Current Monitoring

Technical Data and Specifications

Table 32.2-11. Technical Data—D65CE Series, Standard Current Monitors

Description	Specifications
Input voltage tolerance	AC operation: +10/–15% of nominal voltage at 50/60 Hz
Load (burden)	Less than 5 VA
Current settings: Pickup Dropout	Adjustable throughout current range monitored Fixed at 95% of pick-up setting for D65CE Adjustable from 50–95% of pickup setting for D65CEK
Temperature	–20 to 131°F (–28 to 55°C)
Response times: Pickup Dropout	100 ms 100 ms
Output contacts	10A resistive at 240 Vac / 30 Vdc 1/2 hp at 240 Vac (NO); 1/3 hp at 240 Vac (NC)
Mechanical life	10,000,000 operations
Electrical life	100,000 operations
Indicator LED	Green when input voltage is applied; Red when relay is energized
Reset	Automatic
Mounting	Requires an 8- or 11-pin socket

D65CH Series—Overcurrent Monitors

Overcurrent Monitors



D65CH Series Overcurrent Monitors

General Description

The D65CH Series overcurrent monitoring relays are used to detect an overcurrent condition. The pickup current setting is user-adjustable within one of three ranges as shown in product selection table. An external current transformer can be used to extend the range beyond 10A. Users may select a fixed dropout current setting (95% of the selected pickup setting) or an adjustable dropout setting (50–95% of the selected pickup setting). The relay will energize when the monitored AC current is above the pickup setting for a period longer than the adjustable time delay of 0.1–10 seconds. This delay prevents nuisance tripping caused by inrush currents. It will de-energize when the monitored AC current is below the dropout setting.

Features

- Monitors AC single-phase currents for overcurrent conditions
- Three separate current monitoring ranges covering 0.1–10A
- External CT can be used to extend ranges
- Adjustable pickup setting with either fixed or adjustable dropout setting
- Adjustable time delay of 0.1–10 seconds on pickup
- LED indicates output relay status
- Choice of compact SPDT (8-pin) or DPDT (11-pin) plug-in case
- 10A output contacts

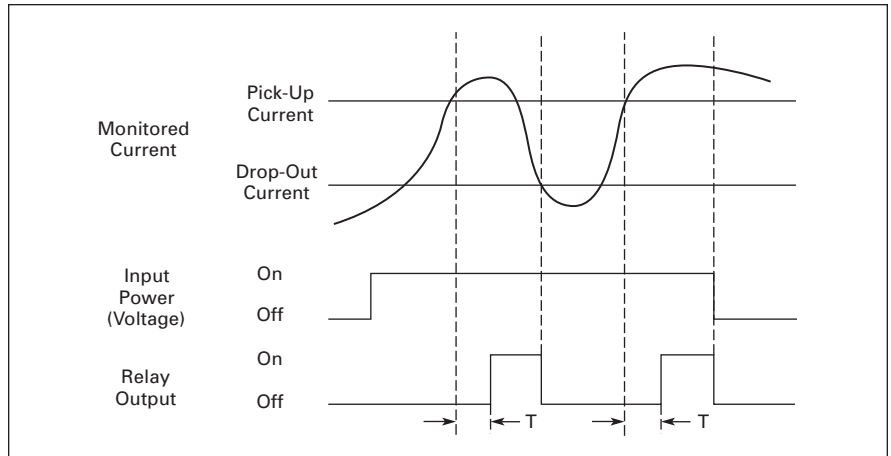

Figure 32.2-18. Overcurrent Monitoring

Technical Data and Specifications

Table 32.2-12. Technical Data—D65CH Series, Overcurrent Monitors

Description	Specifications
Input voltage tolerance	AC operation: +10/–15% of nominal voltage at 50/60 Hz
Load (burden)	Less than 5 VA
Current settings: Pickup Dropout	Adjustable throughout current range monitored Fixed at 95% of pickup setting for D65CH Adjustable from 50–95% of pickup setting for D65CHK
Temperature	–20 to 131°F (-28 to 55°C)
Response times: Pickup Dropout	Adjustable 0.1–10 seconds Fixed at 100 ms
Output contacts	10A resistive at 240 Vac/30 Vdc 1/2 hp at 240 Vac (NO); 1/3 hp at 240 Vac (NC)
Mechanical life	10,000,000 operations
Electrical life	100,000 operations
Indicator LED	Green when input voltage is applied; Red Flashing when in time delay; Red steady when relay is energized
Reset	Automatic
Mounting	Requires an 8- or 11-pin socket

D65CL Series—Undercurrent Monitors

Undercurrent Monitors



D65CL Series Undercurrent Monitors

General Description

The D65CL Series is designed to detect an undercurrent condition. The drop-out current setting is user-adjustable within one of three ranges shown below. An external current transformer can be used to extend the range beyond 10A. The pickup current setting is fixed at +5% of the selected drop-out setting. The relay will energize when the monitored AC current is above the pickup setting. It will de-energize when the monitored AC current is below the dropout setting for a period longer than the adjustable time delay of 0.1–10 seconds. This delay prevents nuisance tripping caused by momentary line dips. The relay will energize when the current rises 5% above the dropout setting.

Features

- Monitors AC single-phase currents for undercurrent conditions
- Three separate current monitoring ranges covering 0.1–10A
- External CT can be used to extend ranges
- Adjustable dropout setting with fixed pickup setting
- Adjustable time delay of 0.1–10 seconds on dropout
- LED indicates output relay status
- Choice of compact SPDT (8-pin) or DPDT (11-pin) plug-in case
- 10A output contacts

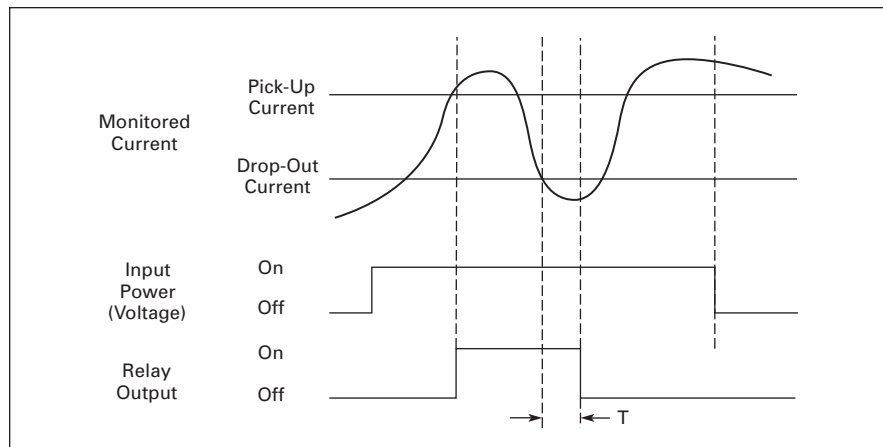

Figure 32.2-19. Undercurrent Monitoring

Technical Data and Specifications

Table 32.2-13. Technical Data—D65CL Series, Undercurrent Monitors

Description	Specifications
Input voltage tolerance	AC operation: +10/–15% of nominal voltage at 50/60 Hz
Load (burden)	Less than 5 VA
Current settings: Pickup Dropout	Fixed at 5% above adjustable dropout setting Adjustable throughout current range monitored
Temperature	–20 to 131°F (–28 to 55°C)
Response times: Pick-up Drop-out	Fixed at 100 ms Adjustable 0.1–10 seconds
Output contacts	10A resistive at 240 Vac/30 Vdc 1/2 hp at 240 Vac (NO); 1/3 hp at 240 Vac (NC)
Mechanical life	10,000,000 operations
Electrical life	100,000 operations
Indicator LED	Green when input voltage is applied; Red flashing when in time delay; Red steady when relay is energized
Reset	Automatic
Mounting	Requires an 8- or 11-pin socket

D65 Series



D65 Series

General Description

The Eaton D65 voltage monitoring relay protects distribution systems supplying motor feeder or branch circuits against premature equipment failure caused by voltage problems on wye or delta connected three-phase systems. Voltage monitoring relays protect against voltage imbalance and single-phasing regardless of any regenerative voltages. The relay is energized when the phase sequence and all voltages are correct. Any of five abnormal conditions (phase loss, phase reversal, overvoltage, undervoltage or phase imbalance) will de-energize the relay. As standard, re-energization is automatic upon correction of the fault condition. The D65 can also be wired for manual reset.

Application Description

Protective Functions

The D65 Series relay makes separate trip decisions based on the status of the three-phase voltage inputs. Control power is derived from the three-phase voltage inputs. Separate control power is not required. The device will trip in response to any combination of the following conditions:

- **Undervoltage**—When voltage in all three lines of a three-phase system drops simultaneously. Undervoltage dropout can be set at 80–95% of operating voltage. Unit trips when the average of all three lines is less than the adjusted set point for a period longer than the adjustable time delay dropout (0.1–20 seconds). This time delay eliminates nuisance tripping caused by momentary voltage fluctuation

- **Overvoltage**—Fixed at 110% of nominal, unit trips when the average of all three lines is greater than the fixed set point for a period longer than the time delay dropout
- **Phase imbalance**—Imbalance of a three-phase system occurs when single-phase loads are connected such that one or two of the lines (phases) carry more or less of the load. This could cause motors to run at temperatures above published ratings. Unit trips when any one of the three lines is more than the adjusted set point below the average of all three lines. The percent phase imbalance is adjustable from 2–10% and also has a Disable setting for applications where poor voltage conditions could cause nuisance tripping
- **Phase loss (single-phasing)**—Total loss of one or more of the three phases. Typically caused by a blown fuse, broken wire or worn contact. This condition would result in a motor drawing locked rotor current during startup. In addition, a three-phase motor will continue to run after losing a phase, resulting in potential motor burn-out. Unit trips on loss of any phase
- **Phase reversal**—Reversing any two of the three phases will cause a three-phase motor to run in the opposite direction. This may cause damage to machinery or injury to personnel. Unit trips if rotation (sequence) of the three phases is anything other than A-B-C

Features

- Universal voltage range of 208–480V provides the flexibility to cover a variety of applications. 120V and 600V units also available
- Automatic or manual reset after the fault condition is corrected
- Multi-color LED indicates normal condition and defines fault type for simpler troubleshooting
- D65VMLS can be either mounted directly on 35 mm DIN rail with no additional parts or to a back-panel with two screws. No socket required. D65VMLP will plug into D3PA2 socket and mount on 35 mm DIN rail
- Small, compact size
- User-adjustable settings include nominal voltage, percent phase imbalance, undervoltage dropout, time delay on undervoltage and time delay on restart after fault

Operation

The D65 provides protection against premature equipment failure caused by voltage faults on three-phase systems. The D65 is designed to be compatible with most wye or delta systems. In wye systems, a connection to a neutral is not required. D65 voltage monitoring relays protect against unbalanced voltages or single-phasing regardless of any regenerative voltages. The relay is energized when the phase sequence and all voltages are correct. Any one of five fault conditions will de-energize the relay. Re-energization is automatic upon correction of the fault condition. Manual reset is available if an NC switch is wired to the appropriate terminals. A multi-color LED indicates normal condition and also provides specific fault indication to simplify troubleshooting. The percent phase imbalance is adjustable from 2–10%, and the undervoltage dropout can be set at 80–95% of operating voltage. The adjustable time delay dropout on undervoltage (0.1–20 sec) eliminates nuisance tripping caused by momentary voltage fluctuations.

Table 32.3-1. LED Operation

LED Status	Indicator
Green steady	Normal/relay ON
Green flashing	Power-up/restart delay
Red steady	Unbalance
Red flashing	Undervoltage/overvoltage
Amber steady	Reversal
Amber flashing	Loss
Alternating green/red	Undervoltage/overvoltage trip pending
Alternating red/amber	Nominal voltage set error

Standards and Certifications

- CE
- cULus (D65VMLS only)
- cURus (D65VMLP only)
- UL listed when used with accompanying Eaton socket.

D65 Series—Voltage Monitoring Relays

Technical Data and Specifications

Table 32.3-2. D65 Series Specifications

Description	Specifications
Nominal voltages (50–60 Hz)	120V, 208–480V, 600V
Connections	Three-wire wye or delta
Output contacts for D65VMLS	SPDT and SPNC (surface mount version only) NO: 10A resistive at 240 Vac/30 Vac, 1/2 hp at 240 Vac NC: 10A resistive at 240 Vac/30 Vdc, 1/3 hp at 240 Vdc
Output contacts for D65VMLP	SPDT: 10A resistive at 240 Vac/30 Vdc; 1/2 hp at 120/240 Vac
Dielectric	1000V + (2 * nominal voltage rating) between input terminals and case or active circuitry
Operating temp.	-20° to 150°F (-28° to 65°C)
Response time Power up Restart after fault Release	1–300 seconds adjustable 1–300 seconds adjustable 100 ms fixed on phase loss and phase reversal; 2 sec fixed on phase imbalance; 0.1–20 sec adjustable on undervoltage only; inverse time curve for overvoltage
Mechanical life Electrical life	10,000,000 operations 100,000 operations
Power consumption	3 VA
Net Weight	10.3 oz (292g) D65VMLS 6.4 oz (181g) D65VMLP
Hysteresis	2–3%

Dimensions

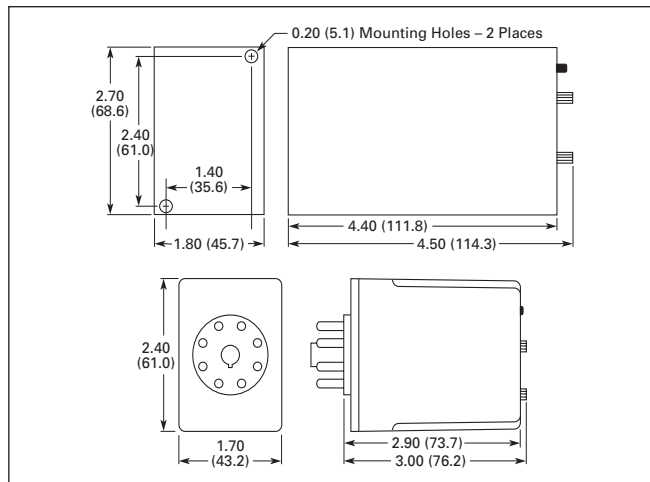

Figure 32.3-1. Surface-Mount and Plug-In—Approximate Dimensions in Inches (mm)

Wiring Diagrams

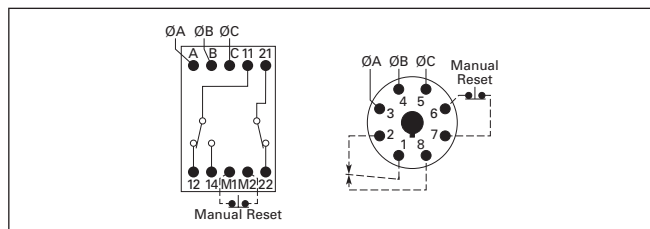

Figure 32.3-2. Surface-Mount and Plug-In Wiring Diagrams

Typical Connections

Line Side Monitoring

With the relay connected before the motor starter, the motor can be started in the reverse direction. However, the motor is unprotected against phase failures between the relay and the motor.

Load Side Monitoring

With the relay connected directly to the motor, the total feed lines are monitored. This connection should not be used with reversing motors.

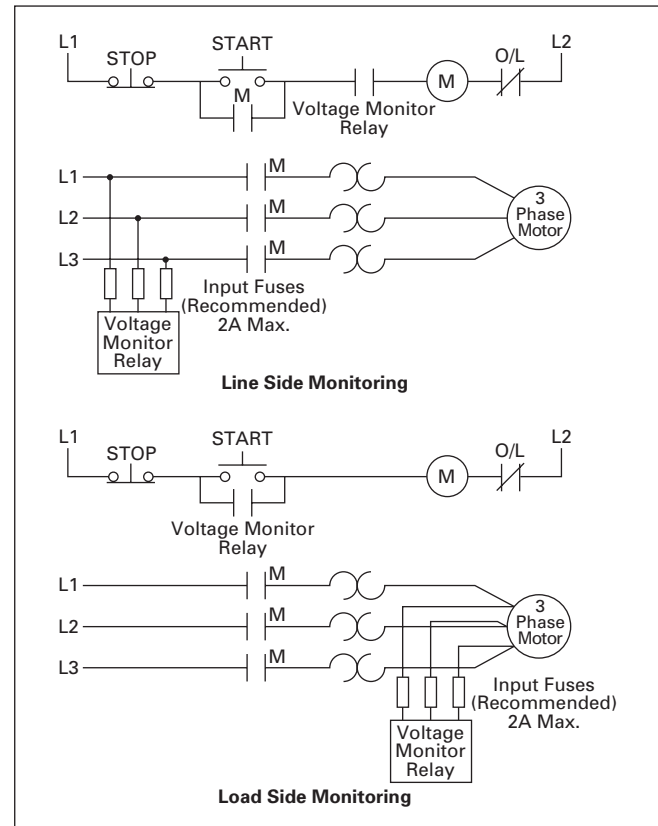

Figure 32.3-3. Line Side and Load Side Monitoring

Product Selection

When Ordering Specify

- Catalog number

Table 32.3-3. Voltage Monitoring Relay

Mounting Style	Operating Voltage, 50/60 Hz	Catalog Number
Surface-mount (DIN rail or panel)	120V 208–480V 600V	D65VMLS120 D65VMLS480 D65VMLS600
Plug-in (DIN rail)	120V 208–480V	D65VMLP120 D65VMLP480 ①
8-pin socket	—	D3PA2

① Requires a 600V-rated socket when used on system voltages greater than 300V. The D3PA2 socket is rated 10A, 600V.

D65 Series—Voltage Band Relays

D65 Series—
Voltage Band Relay

D65 Series

General Description

Monitors AC single-phase and DC voltages; provides voltage band (window) protection, wide range of overvoltage, undervoltage and time delay settings; LED indicates output relay status.

Features

Input Voltage

- 24 Vac, 10 Vac, 12–110 Vdc
- Tolerance: +25/–50% of nominal voltage
- AC voltages are 50/60 Hz
- No separate supply (input) voltage is required

Output Contacts

- 10A resistive at 240 Vac/30 Vdc
- 1/2 hp at 240 Vac (NO)
- 1/3 hp at 240 Vac (NC)

Load (Burden)

- Less than 3 VA

Pickup and Dropout Settings

- Pickup: 100–125% of nominal voltage
- Dropout: 75–100% of nominal voltage

Temperature

- –20° to 131°F (–28° to 55°C)

Response Times

- Pickup: 500 ms
- Dropout: Fixed 600 ms (D65VWP Series); adjustable 0.5–10 seconds (D65VWKP Series)

Mechanical Life

- 10,000,000 operations

Electrical Life

- 100,000 operations

Indicator LED

- Red steady: relay is energized
- Green: relay if OFF

Reset

- Automatic (contact Eaton for information on how to order a unit with manual reset)

Mounting

- DIN mount with an 8-pin socket

Standards and Certifications

- cURus
- cULus
- RoHS
- CE

D85 Series—Alternating Relays

D85 Series—
Alternating Relays

D85 Series

General Description

For duplex load monitoring; works with one to three control switches (LEAD, LAG, STOP); optional low profile selector switch to lock in one sequence; two LEDs indicate relay status.

Features

Input Voltage

- 120–240 Vac
- Tolerance: +10/–150% of control voltage at 50/60 Hz
- Transient Protection: 10,000V for 20 microseconds

Output Contacts

- 10A resistive at 240 Vac/30 Vdc
- 1/2 hp at 240 Vac

Load (Burden)

- Less than 3 VA

Temperature

- –20° to 150°F (–28° to 65°C)

Mechanical Life

- 10,000,000 operations

Electrical Life

- 100,000 operations

Indicator LED

- Two LEDs: marked LOAD A and LOAD B

Mounting

- DIN mount with an 8- or 11-pin socket







Standards and Certifications

- cURus
- cULus
- RoHS
- CE

General Purpose Plug-In Relays Selection Guide















Product Selection

Table 32.4-1. General Purpose Plug-In Relays

Relay Series			
	D1PR/D1PF	D2PR/D2PF	D3PR/D3PF
Approvals			
Features	Polycarbonate cover Indicator lamp and pushbutton available Panel and DIN mounting	Polycarbonate cover Indicator lamp and pushbutton available Panel, DIN and flange mounting Latching	Polycarbonate cover Indicator lamp and pushbutton available Panel and DIN mounting 8- or 11-pin octal plug-in Latching (D3PR version)
Contact Data			
Configuration	SPDT	DPDT	DPDT Latching 4PDT DPDT Latching DPDT 3PDT
Max. allowable load	20A	10A	10A 10A 16A 16A 16A
Material	Silver alloy	Silver alloy	Silver alloy
Dielectric strength between poles	1500V	1500V	1500V
Coil Data			
AC	6–240 Vac	6–240 Vac	6–240 Vac
DC	6–110 Vdc	6–110 Vdc	6–110 Vdc
Power VA (Vac) Watts (Vdc)	0.9 VA 0.7W	1.2 VA 0.9W	3 VA 1.4W (D3PR and D3PF) 2 VA 1.64W (D3PR5 latching)
General Data			
Ambient temperature			
Storage	–40° to 185°F (–40° to 85°C)	–40° to 185°F (–40° to 85°C)	–40° to 185°F (–40° to 85°C)
Operational	–40° to 131°F (–40° to 55°C)	–40° to 131°F (–40° to 55°C)	–40° to 131°F (–40° to 55°C)
Response time	20 milliseconds	20 milliseconds	20 milliseconds
Life			
Mechanical operations	10 million	10 million	5 million (D3PR and D3PF) 10 million (D3PR5 latching)
Electrical operations	100,000	200,000	100,000





General Purpose Plug-In Relays Selection Guide

Table 32.4-1. General Purpose Plug-In Relays (Continued)

Relay Series									
	D4	D5PR/D5PF	D7PR/D7PF						
Approvals	   	   	   						
Features	Polycarbonate cover Indicator lamp available Panel and DIN mounting Socket has built-in hold-down spring	Polycarbonate cover Indicator lamp and pushbutton available Panel, DIN and flange mounting	Polycarbonate cover Indicator lamp and pushbutton available Panel and DIN mounting						
Contact Data									
Configuration	SPDT	DPDT	DPDT	3PDT	SPDT	DPDT	3PDT	4PDT	
Max. allowable load	10A at 250 Vac	5A at 240 Vac	16A	16A	20A	15A	15A	15A	
Material	AgCdO			Silver alloy		Silver alloy			
Dielectric strength	5000V			1500V		1500V	1500V	2500V	2500V
Coil Data									
AC	6–240 Vac		6–240 Vac		6–240 Vac				
DC	6–110 Vdc		6–110 Vdc		6–110 Vdc				
Power									
VA (Vac)	0.9 VA		3 VA		1.2 VA	1.2 VA	1.5 VA	1.5 VA	
Watts (Vdc)	0.5W		1.4W		0.9W	0.9W	1.4W	1.5W	
General Data									
Ambient temperature									
Storage	–40° to 158°F (–40° to 70°C)		–40° to 185°F (–40° to 85°C)		–40° to 185°F (–40° to 85°C)				
Operational	–40° to 158°F (–40° to 70°C)		–40° to 131°F (–40° to 55°C)		–40° to 131°F (–40° to 55°C)				
Response time	15 milliseconds		20 milliseconds		20 milliseconds (30 milliseconds for latching)				
Life									
Mechanical operations	10 million		5 million		10 million				
Electrical operations	100,000		100,000		100,000	100,000	200,000	200,000	









General Purpose Plug-In Relays Selection Guide

Table 32.4-1. General Purpose Plug-In Relays (Continued)

Relay Series			
	D8	D9	
Approvals			
Features	Dust cover Panel, DIN and flange mounting Quick-connect and screw terminals	Dust cover Pushbutton available Panel mounting Screw terminals	
Contact Data			
Configuration	SPST-NO	DPST-NO	4PST
			NO NC
Max. allowable load	30A at 220 Vac	25A at 220 Vac	25A at 220 Vac 8A at 220 Vac
Material	AgCdO		AgCdO
Dielectric strength	4000V		4000V
Coil Data			
AC	6–240 Vac	24–240 Vac	
DC	12–24 Vdc	12–110 Vdc	
Power			
VA (Vac)	2.5 VA	2.6 VA	
Watts (Vdc)	1.9W	2.0W	
General Data			
Ambient temperature			
Storage	–4° to 185°F (–20° to 85°C)	–13° to 140°F (–25° to 60°C)	
Operational	–4° to 131°F (–20° to 55°C)	–13° to 140°F (–25° to 60°C)	
Response time	30 milliseconds	50 milliseconds	
Life			
Mechanical operations	5 million	1 million	
Electrical operations	100,000	100,000	







Multi-Pole Relay Selection Guide

Table 32.4-2. Multi-Pole Relays

Relay Series				
	D15 Freedom 600V Multi-Pole Relays	BF/BFD Fixed Contact Industrial Control Relays	AR/ARD Convertible Contact Industrial Control Relays	D26 Type M, 600 Vac Multi-Pole Relays with Convertible Contacts
Approvals				
Features	Indicator shows ON/OFF status; relay base has mounting holes to replace competitive product; terminals are finger-proofed	Captive clamp terminals fully front-accessible, low operating temperature, silver alloy contacts suitable for low voltage circuits	Wide-spaced contacts simplify installation, testing and conversion from NO to NC	AC and DC multi-pole relays with field-convertible contacts; many accessories available for complete flexibility in product offering
Mounting	Panel or 35 mm DIN rail	Panel mount	Panel mount	Panel mount
Contact ratings	NEMA A600 10A continuous thermal rating (AC) NEMA P300 5A continuous thermal rating (DC)	NEMA A300 10A at 120/240 Vac 1/6 hp at 115 Vac—single-phase 1/2 hp at 230 Vac—single-phase 1 hp at 230 Vac—three-phase NEMA P300 5A at 125/250 Vdc	NEMA A600 10A at 120/240/480/600 Vac NEMA P600 5A at 125/250/600 Vdc	NEMA A600 10A at 120/240/480/600 Vac
Number of poles	4–8 (NO and NC combinations)	2–12 (NO and NC combinations)	4–10 (NO and NC combinations)	4–12 (NO and NC combinations)
Available coils	24–600 Vac, 12–120 Vdc	12–440 Vac, 6–240 Vdc	12–600 Vac, 12–240 Vdc	6–600 Vac, 12–240 Vdc
Accessories	Pneumatic timer attachment Finger protection shields Adhesive dust cover Interface module	Solid-state timer attachment Permanent magnet latch FASTON push-on terminals Overlapping contacts NEMA 1 enclosure	Mechanical latch attachment Solid-state timer attachment Ring-type connectors Overlapping contacts	Pneumatic timer Mechanical latch Overlapping contacts Indicating light Test accessory Transient suppressor Mounting channel

Solid-State Relays

Table 32.4-3. Solid-State Relays

Relay Series			
	D93 Hockey Puck	D96 IEC Style	D99 Integrated Heat Sink
Approvals			
Features	LED input indicator, finger-safe terminals, optically coupled circuit, available Triac and MOSFET outputs for DC-operated relays	LED input indicator, integral heat sink, isolated output terminals, screw terminals accept up to 14 AWG wire, SCR output type	LED input indicator, integral heat sink, flexible mounting, finger-safe terminals
Mounting	Panel mount	DIN rail or panel mount	DIN rail or panel mount
Contact ratings	10–75A	8, 10, 15A	10, 25, 40A
Output voltage	24–280 Vac/3–200 Vdc	3–50 Vdc/24–280 Vac/48–480 Vac/48–600 Vac	24–280 Vac/48–660 Vac
Number of poles	SPST/NO	SPST/NO or NC	SPST/NO
Available coils	90–280 Vac/3–32 Vdc	90–280 Vac/3–32 Vdc/3.5–32 Vdc	3–32 Vdc/90–280 Vac or 80–140 Vdc
Accessories	Heat sink Heat transfer thermal pad	N/A	N/A

This page intentionally left blank.

Universal TR Series



Universal TR Timing Relays

General Description

Eaton’s Universal TR Series timers are our most flexible and cost-effective timing relays available. Products are available with up to seven user-selectable functions and seven user-selectable time ranges. Each unit is DIN rail mountable with a direct connection, eliminating the need for additional sockets. The Universal TR Series timers are available in SPDT and DPDT contact configurations, and have a compact IEC-style footprint and a universal input voltage range for AC and DC applications.

Features

- Multiple user-selectable timing functions and timing ranges in a single unit reduce product variations and stock keeping units (SKUs)
- Universal input voltages from 12V or 24–240 Vac or Vdc eliminate the need to order and stock separate coil voltages
- Compact, DIN rail mountable case reduces panel size
- Advanced LED indication makes troubleshooting easy
- Staggered terminal locations allow access to lower-level terminals after wiring
- SPDT or DPDT contacts with 8A ratings

Product Selection

Table 32.5-1. Universal TR Timing Relays

Supply Voltage	Description	Catalog Number
Four-Function		
24–240 Vac/Vdc	Compact DIN rail mount, SPDT	TRL04
Seven-Function		
24–240 Vac/Vdc	Compact DIN rail mount, SPDT	TRL07
12–240 Vac/Vdc	Compact DIN rail mount, DPDT	TRL27
	Asymmetrical pulse generator, DPDT	TRW27

1/32 DIN LCD—Timers



E5-224

General Description

Simple battery-powered timers provide an easy-to-read LCD and a variety of timing display options.

Features

- Low price and high efficiency
- Large eight-digit LCD display, height of the figures 0.31 inches (7.9 mm)
- Different time ranges from 0.1 second to 100,000 hours
- 0.1 second synchronization makes it suitable for very short activation times
- High voltage input for 10–260 Vac/Vdc voltage pulses
- IP65
- Screw terminals, RM 5 mm
- Lifetime of the battery approximately eight years
- Locking of the reset key
- Operating temperature 14° to 140°F (–10 to 60°C)

Standards and Certifications

- UL recognized
- CE marked

Product Selection

Table 32.5-2. 1/32 DIN LCD Timers

Description	Catalog Number
Eight-Digit LCD Timer, Battery Power	
Hours/minutes, 0.94 x 1.89 inches (24.0 x 48.0 mm)	E5-224-C0440
Hours/minutes, 10–260V input, 0.94 x 1.89 inches (24.0 x 48.0 mm)	E5-224-C0448
Minutes/seconds, 0.94 x 1.89 inches (24.0 x 48.0 mm)	E5-224-C0450
Minutes/seconds, 10–260V input, 0.94 x 1.89 inches (24.0 x 48.0 mm)	E5-224-C0458

Technical Data and Specifications

Table 32.5-3. General Specifications

Description	Specification
Power supply	Non-replaceable lithium battery (lifetime approximately eight years at 68°F (20°C))
Display	LCD, eight-digit
Figure size	0.31 inches (7.9 mm) high
Counting direction	Adding
Display range	
Time range	99999h 59m (134)
Display	
Time range	99999.99h (134)
Display	
Time range	9999h 59m 59s (135)
Display	
Time range	9999999.9s (135)
Display	
Reset	Manual and electrical
Timer inputs, DC versions (max. 30 Vdc)	
Timer input	NPN or PNP depending on the type
Switching level	
NPN low	0–0.7V
NPN high	3–30 Vdc
PNP low	0–0.7V
PNP high	4–30 Vdc
Counting Start	
NPN	For low signal at the timer input
PNP	For high signal at the timer input
Timer inputs, high voltage version (10–260 Vdc/Vac)	
Timer input	Optocoupler input max. 30 Hz
Min. pulse time	16 ms
Switching level	
Low	0–2 Vdc/Vac
High	10–260 Vdc/Vac
Counting start	For high signal at the timer input
Time range change (mode)	
Contact input—open collector (switching at 0V)	
NPN low	0–0.7V
NPN high	3–5 Vdc
Time range	Depending on the circuit
Reset Input (only DC and high voltage)	
Minimum pulse time	
DC	50 ms
High voltage	10 ms
Contact input (DC)	
NPN low	0–0.7V
NPN high	3–30 Vdc
High voltage input	10–260 Vdc/Vac
Reset locking input (for DC and AC), electrical reset key locking	
Input not active	Reset key locked
Contact input	Open collector NPN (switching at 0V)
Switching level	
NPN low	0–0.7V
NPN high	3–5 Vdc
Interference emissions	EN 55011 Class B, EN 61 000-6-2, EN 61010 Section 1 (only AC versions)
Housing	Dark gray RAL 7021
Operating temperature	14° to 131°F (–10° to 55°C)
Ambient temperature	14° to 140°F (–10° to 60°C)
Storage temperature	–4° to 158°F (–20° to 70°C)
Protection	IP65 (from front)
Weight	Approx. 1.76 oz (50g)

Dimensions

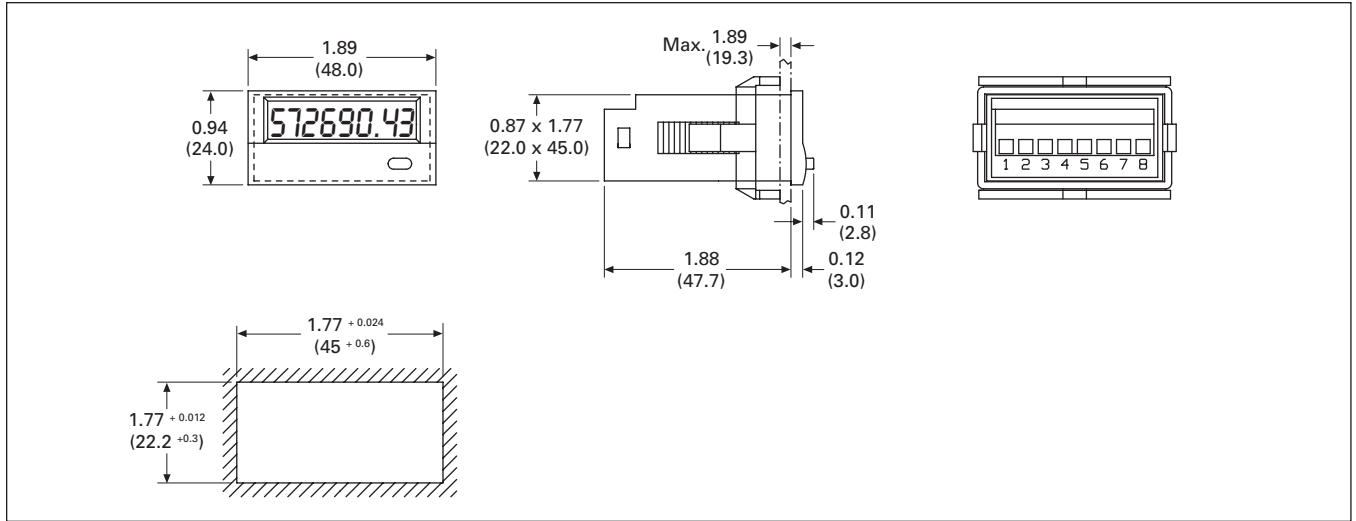

Figure 32.5-1. 1/32 DIN LCD Timers—Approximate Dimensions in Inches (mm)

E42DP50, E42A24M Series and Panel Meters—Eclipse Series—Durant®

E42DIR Series Elapsed Timers



E42DIR

Features

- Solid-state hour meter
- Records and displays up to 99,999.9 hours, rolls over and continues timing
- Continuous display available
- EEPROM can retain data for 25+ years
- Operates in a temperature range of -40° to 185°F (-40° to +85°C) and in harsh conditions of vibration, shock, moisture and dust
- Minimal power consumption
- Designed for easy panel-mount installation
- Compact behind-panel depth
- Operating indicator (hourglass icon)
- Memory will arm only when power has been applied for five seconds

Standards and Certifications

- CE marked

Catalog Numbering System

Table 32.5-4. E42DIR Series Elapsed Timers

E42 DI X X X	
R = Round 24 = Rectangular	Blank = Non-reset
48230 = 48–150 Vdc/ 100–230 Vac	
1260 = 12–48 Vdc/ 20–60 Vac	

E42A24M Series



E42A24M

Features

- Powered time control AC/DC
- Analog time relay
- Seven timing modes
- Panel mounted
- 0.02 sec to 300 hours
- 24–240 Vac/12–240 Vdc
- DPDT relay

Standards and Certifications

- UL
- CSA®
- CE marked

Eclipse Series—Durant®



Eclipse Series Panel Meter

General Description

Eaton's Eclipse Series panel meter features a high-visibility LED and is available with a variety of input and scaling options.

Features

Input Voltage

- Four full digits
- 1/8 DIN size
- Red, LED display
- 0.56-inch (14.2 mm) high characters
- Scalable display
- Flashing alarms
- Maximum/minimum data hold
- Optional analog, relay and RS-485 outputs
- NEMA 4X
- Depluggable terminal blocks

Standards and Certifications

- UL and cUL listed
- CE marked
- CSA

Catalog Numbering System

Table 32.5-5. Eclipse Series

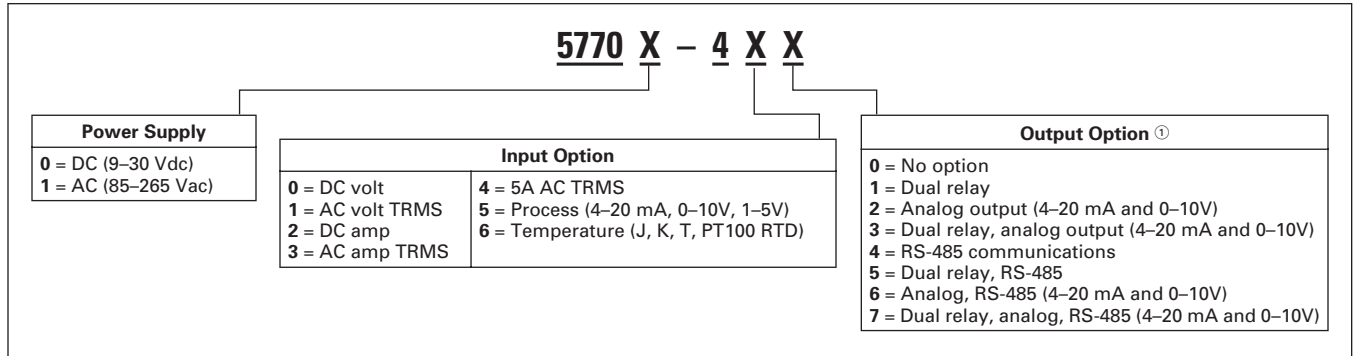

① Output options 0, 2, 4 are not available for models -41X and -43X.

Technical Data and Specifications

Table 32.5-6. General Specifications

Description	Specification
Input Power	
AC powered models (57751-4XX) Input power External fuse Isolation dielectric strength	85–265 Vac, 47–63 Hz, 20 VA 0.2A, 250 Vac, time delay (T200 mA, 250V) 2300 Vac
DC powered models (57750-4XX) Input power External fuse Reverse voltage protection Isolation dielectric strength	9–30 Vdc, 12 VA 2.0A, 50 Vdc, time delay (T2A, 50V) Yes 2300 Vac to signal inputs and relays, 500 Vac to RS-485 and analog outputs
Human Interface	
Display	±4 full digits
Type	0.56-inch (14.2 mm) high, seven segment, red LED
Update time	0.4 seconds
Alarm	Flashing display
Indicator	One red LED program/calibration indicator with max./min. capture and hold
Data Retention	
Memory type	EEPROM, no batteries required
Duration	100 years
Signal Input	
DC voltage models (5770X-40X) Range Impedance Overrange Accuracy	±199.9m Vdc, ±1.999 Vdc, ±19.99 Vdc, ±199.9 Vdc, DIP switch selectable 1 mohm 750 Vdc/530 Vac except 220 Vdc/Vac on 199.9 mV range ±0.1% of reading, ±0.03% FS, ±0.5 digit, and ±80 PPM/°C
AC voltage models (5770X-41X) Range Frequency Impedance Overrange Accuracy	199.9 m Vac, 1.999 Vac, 19.99 Vac, 199.9 Vac, DIP switch selectable, all ranges true rms 40–1000 Hz 1 mohm (capacity coupled) 750 Vdc/530 Vac except 220 Vdc/Vac on 199.9 mV range ±0.5% of reading, ±0.13% FS, ±0.5 digit, ±180 PPM/°C for crest factor = 1; plus ±0.7% for crest factor = 1–3; and ±2.5% for crest factor = 5
DC current models (5770X-42X) Range Impedance Overrange Accuracy	±199.9 µA DC, ±1.999 mA DC, ±19.99 mA DC, ±199.9 mA DC, DIP switch selectable 199.9 mV/selected range 30 mA (199.9 µA range), 100 mA (1.999 mA range), 300 mA (19.99 mA range), 1A (199.9 mA range) ±0.1% of reading, ±0.03% FS, ±0.5 digit and ±120 PPM/°C
AC current models (5770X-43X) Range Frequency Impedance Overrange Accuracy	199.9 µA AC, 1.999 mA AC, 19.99 mA AC, 199.9 mA AC, DIP switch selectable, all ranges true rms 40–1000 Hz 199.9 mV/selected range (shunt output capacitive coupled) 30 mA (199.9 µA range), 100 mA (1.999 mA range), 300 mA (19.99 mA range), 1A (199.9 mA range) ±0.5% of reading, ±0.13% FS, ±0.5 digit and ±200 PPM/°C for crest factor = 1; plus ±0.7% for crest factor = 1–3; and ±2.5% for crest factor = 5

Panel Meters—Eclipse Series

Table 32.5-6. General Specifications (Continued)

Description	Specification
Signal Input (Continued)	
5A AC models (5770X-44X) Range Frequency Impedance Overrange Accuracy	5A AC, true rms 40–1000 Hz 0.02 ohm (shunt output capacitive coupled) 10A maximum ±0.4% of reading, ±0.13% FS, ±0.5 digit, and ±200 PPM/°C for crest factor = 1; plus ±0.7% for crest factor = 1 to 3; and ±2.5% for crest factor = 5
Process models (5770X-45X) Range Impedance Overrange Power output Accuracy	4–20 mA DC, 0–10 Vdc, 1–5 Vdc; separate input terminals for voltage and current signals 100 ohms (current input) and 1.27 mohms (voltage input) 50 mA maximum (current input) and 100V maximum (voltage input) 24 Vdc ±10%, 90 mA max, short-circuit protected ±0.1% of reading, ±0.03% FS, ±0.5 digit and ±80 PPM/°C
Optional Outputs	
Relay board Dual relay Contact rating Isolation dielectric strength	One set of Form C contacts each 5A, 250 Vac or 30 Vdc 2300 Vac
Analog retransmission Output signals Accuracy Isolation dielectric strength	4–20 mA (<750 ohms) and 0–10V (>2500 ohms) 0.13% FS, 100 PPM/°C, 0.07% FS change with 4–20 mA load, ±0.3% FS for 4–20 mA output, only after exposure to 85% relative humidity 2300 Vac to signal inputs, relays and AC power input; 500 Vac to RS-485 and DC power inputs
RS-485 serial communication Baud rate Parity Address range Protocol Isolation dielectric strength	1200, 2400, 4800, 9600 or 19,200, programmable Even, odd or no parity 00 to 99 decimal Opto 22® compatible 2300 Vac to signal inputs, relays and AC power input; 500 Vac to analog outputs and DC power inputs
Environmental	
Operating environment	Indoor use to 2000 meters
Temperature Operating Storage	32° to 122°F (0° to 50°C) –4° to 158°F (–20° to 70°C)
Humidity	0 to 85% RH, noncondensing
Vibration	2.5 Gs, 30–200 Hz
Shock	30 Gs, 11 ms half sinewave
EMC/EMI	Per EN 61326-1 industrial
Front panel	NEMA 4X when mounted with gasket provided
Agency approval	CE EMC immunity and emissions requirements were met using shielded wiring on the RS-485, analog output and signal input lines. The shields were connected to earth ground at the Eclipse end of the shields. Conducted emissions requirements were met assuming that the AC signal input would not be connected directly to the AC mains. The measurement error during RF immunity testing was less than ±5% of full scale. In addition, models with an AC signal input had measurement error of less than +25% of full scale during RF immunity testing of the RS-485 at frequencies below 1 MHz.
Pollution degree 2	Overvoltage Category II

Dimensions

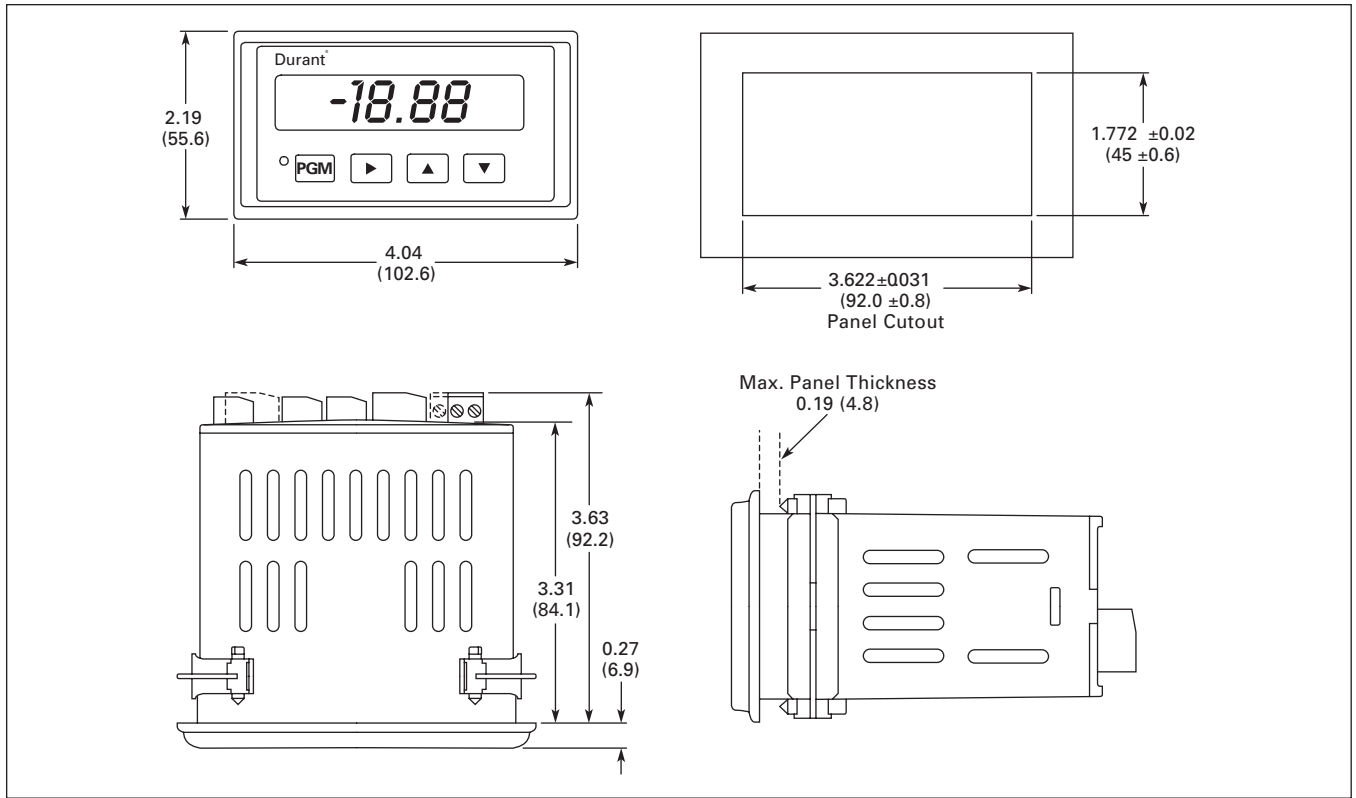

Figure 32.5-2. Eclipse Series—Approximate Dimensions in Inches (mm)

This page intentionally left blank.