

Features

- Screw-mounting model.
- High resolution with a 0.5-mm-wide sensing aperture.
- With a 5-mm-wide groove.
- Photo IC output signals directly connect with C-MOS and TTL.
- Connects to Tyco Electronics AMP's EI-series connectors.

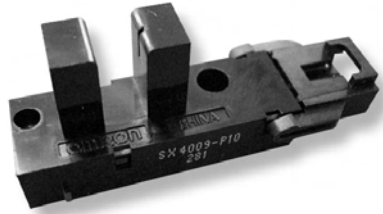

Specifications

■ **Absolute Maximum Ratings (Ta = 25°C)**

Item		Symbol	Rated value
Power supply voltage		V _{CC}	10 V
Output voltage		V _{OUT}	28 V
Output current		I _{OUT}	16 mA
Permissible output dissipation		P _{OUT}	250 mW (see note)
Ambient temperature	Operating	T _{opr}	-25°C to 75°C
	Storage	T _{stg}	-40°C to 85°C
Soldering temperature		T _{sol}	–

Note: Refer to the temperature rating chart if the ambient temperature exceeds 25°C.

■ **Electrical and Optical Characteristics (Ta = 25°C, V_{CC} = 5 V ± 10%)**

Item	Symbol	Value	Condition
Current consumption	I _{CC}	30 mA max.	With and without incident
Low-level output voltage	V _{OL}	0.3 V max.	I _{OUT} = 16 mA Without incident (EE-SX3009-P1) With incident (EE-SX4009-P1)
High-level output voltage	V _{OH}	(V _{CC} × 0.9) V min.	V _{OUT} = V _{CC} With incident (EE-SX3009-P1) Without incident (EE-SX4009-P1), R _L = 47 kΩ
Response frequency	f	3 kHz min.	V _{OUT} = V _{CC} , R _L = 47 kΩ (see note)

Note: The value of the response frequency is measured by rotating the disk as shown below.

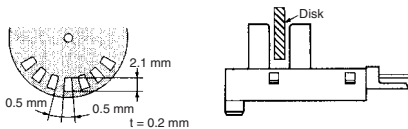

■ Dimensions

Note: All units are in millimetres unless otherwise indicated.

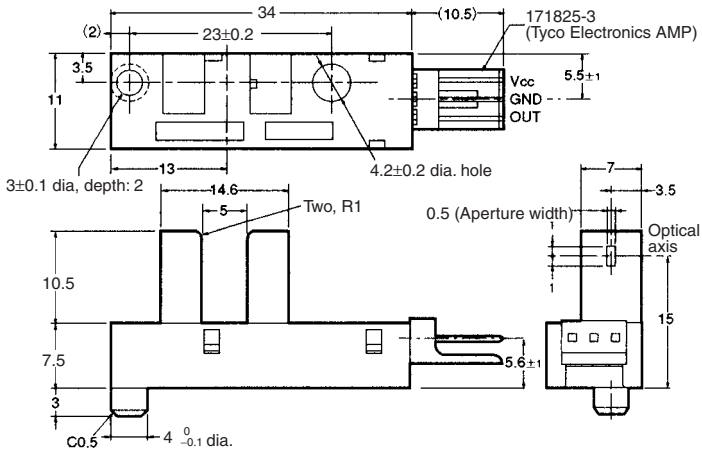

Internal Circuit

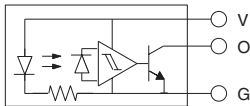

Unless otherwise specified, the tolerances are shown below

Terminal No.	Name
V	Power supply (Vcc)
O	Output (OUT)
G	Ground (GND)

Dimensions	Tolerance
4 mm max.	±0.2
1 < mm ≤ 16	±0.3
16 < mm ≤ 63	±0.5

Recommended Mating Connectors:

Tyco Electronics AMP 171822-3 (crimp-type connector)
 172142-3 (crimp-type connector)
 OMRON EE-1005 (with harness)

■ Engineering Data

Output Allowable Dissipation vs. Ambient Temperature Characteristics

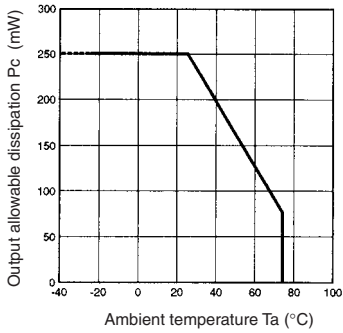

Sensing Position Characteristics (Typical)

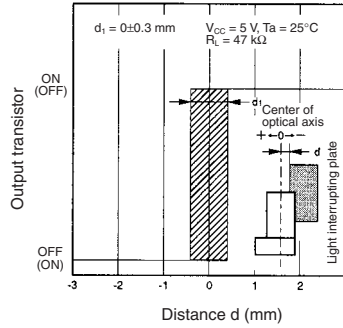

EE-1005 Connector

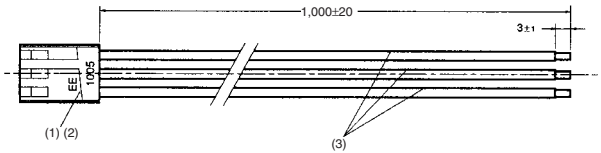

Number	Name	Model	Quantity	Maker
1	Receptacle housing	171822-3	1	Tyco Electronics AMP
2	Receptacle contact	170262-1	3	Tyco Electronics AMP
3	Lead wire	UL1007 AWG24	3	-

■ Wiring

Connector circuit no.	Lead wire colour	Output when connected to EE-SX4009-P1
1	Red	V_{CC}
2	Orange	GND
3	Yellow	OUT