

Specification for Approval

Customer :

Part Name : **AC ADAPTER**

Description : **12.0Volts / 5.0Amps**

Model No. : **STD-1250BE (Level V)**

Customer P / N : **SW4264**

Product P / N : **RXTD1250BE415201**

Issued Date : **03-Aug.-2011**

Version : **A1**

Issued Stamp :

Customer's Approval Signature

Customer's Approval Signature

<p style="text-align: center;">60.0W AC Adapter SPECIFICATION</p>

Model No. : **STD-1250BE (Level V)**

Description : **12.0Volts / 5.0Amps**

Part No. : **RXTD1250BE415201**

Version : **A1**

Date : **03-Aug.-2011**

Approved	Checked	Prepared
		<i>Jarvis</i>

1. Feature :

- ◆ **Input** : **Universal 100 ~ 240 Vac / 47 ~ 63 Hz Input, without any slide switch.**
- ◆ **Output** : **+12.0V / 0~5.0A**
- ◆ **Case Dimension** : **138 (L) *56 (W) * 37 (H) mm**
- ◆ **Efficiency** : **Eff (av) \geq 87% Min**
- ◆ **Safety** :
- ◆ **EMI** : **CE / FCC Class B ; Conduction & Radiation Met.**
- ◆ **Protection** : **OVP (Over Voltage Protection) 、 SCP (Short Circuit Protection) 、 OCP (Over Current Protection)**
- ◆ **High frequency design , less power consumption.**
- ◆ **Suitable for usage at Telecommunication, Computer, Industrial Controller, & OA System.**
- ◆ **Meet Energy Star V / Erp (Stage 2) / MEPS V**

2. Input :

2.1 Voltage	Universal 100~240Vac, single phase
2.2 Frequency	47 ~ 63 Hz
2.3 Current	1.4A Max.
2.4 Inrush Current	80A Max. / 230Vac (Cold start at 25 °C , full load)
2.5 Efficiency	Eff (av) \geq 87% Min (At 115 Vac & 230 Vac)
2.6 Power Consumption	Pi \leq 0.5 W (At 230Vac & No load)

$$\text{※Eff (av)} = \frac{E_1 + E_2 + E_3 + E_4}{4}$$

E1=efficiency with 25% rated load ; E2= efficiency with 50% rated load
E3=efficiency with 75% rated load ; E4= efficiency with 100% rated load

3. Output :

3.1 DC Output	Voltage	+12.00V \pm 5%
	Current	5.0A Max.
	Regulation	11.40Vmin. ~ 12.00Vtyp. ~ 12.60Vmax.
	Ripple & Noise	200mV Max.
	Total Power	60.0W Max.

Remark : For ripple & noise measurement, use a 20MHz bandwidth frequency oscilloscope, and add a 0.1 μ F multilayer Cap. and a Low ESR Electrolytic Cap. (10 μ F) at output connector terminals. (At nominal line voltage, full load)

4. Protection :

4.1 Over Voltage Protection (OVP)	V out *(110%~150%)
4.2 Short Circuit Protection (SCP)	Automatic recovery after short-circuit fault being removed
4.3 Over Current Protection(OCP)	I out *(105%~180%)

Remark : When Short Circuit Protection or Over Current Protection is activated,the power supply will shutdown automatically. Once the abnormal condition resulting in the failure being removed, the power supply will restart accordingly. When Over Voltage Protection is activated, the power supply will shutdown latch .

5. Safety 、EMI and EMC Requirement :

5.1 Safety Requirement

a. Safety :

b. Dielectric Strength : Cut off current 10mA

Primary to Secondary	3000Vac for 1 Minute
----------------------	----------------------

c. Insulation Resistance :

Primary to Secondary	10 M ohm for 500Vdc
----------------------	---------------------

5.2 EMI Requirement : CE / FCC Class B ; Conduction & Radiation Met.

5.3 Leakage Current : Less than 0.25mA

6. Operation and Environment Performance :

6.1 Temperature Range

Operating	+ 0°C ~ + 40°C
Storage	- 20 °C ~ + 80°C

6.2 Humidity Range(Non-condensing)

Operating	20% ~ 80% RH
Storage	10% ~ 90% RH

6.3 Cooling : By natural air.

7. M.T.B.F. : 50,000 Hrs.(At 25°C , By MIL-HDBK-217F)

8.Mechanical :

8.1 Weight : 386 g Typical

8.2 Cable Type : Black UL1185 AWG16
(Wire + Plug)

Plug : $\phi 5.5 * \phi 2.1 * 12.0 \text{mm}$
(Tuning Fork & Cannelure)

Cable Drawing No. :

8.3 Cable Length : 1500mm

8.4 Case Dimension : 138mm(L)*56mm(W)*37mm(H)

8.5 Material Flammability : UL 94V-0

8.6 External Apperance : As drawing below (Scale \rightarrow mm)

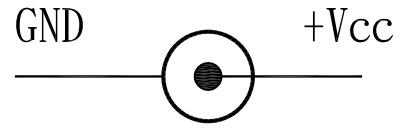

Output Cable Plug Pin Assignment

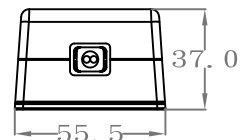
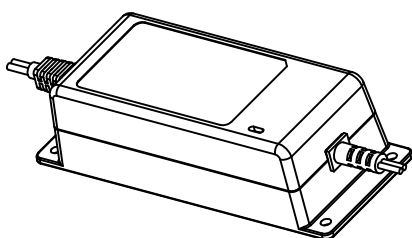
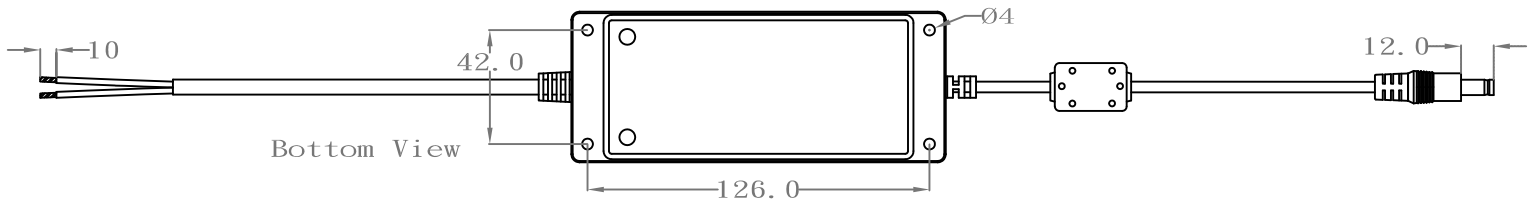
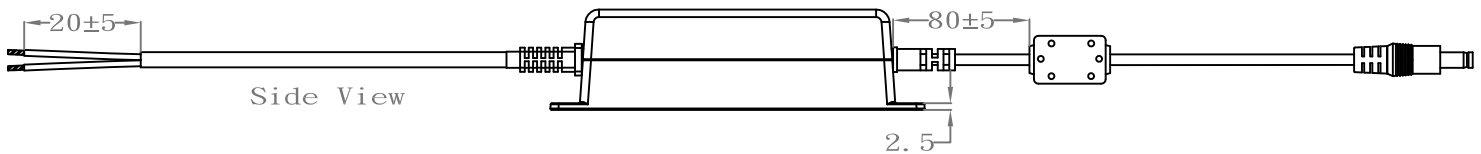
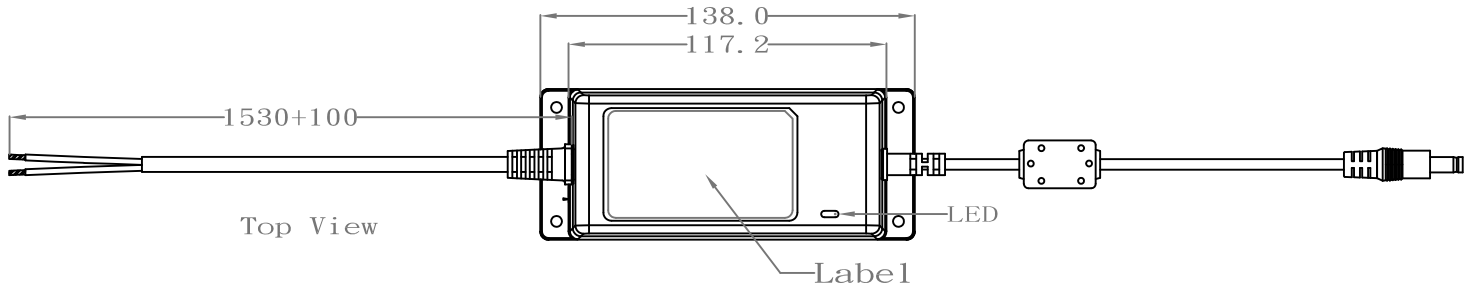
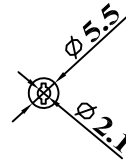

8.7 Spec. Label Materials : Metalized Polyester Label (Silver Gloss)
 Color : Black Background with Silver Printing
 Label Dimension : 70.0mm(L)*40.0mm(W)+/-0.1mm
 Label Thickness : 0.1mm

100%

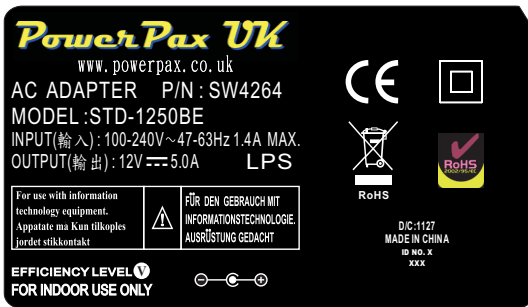

"XXX"

Label supplier's code.
 It is accurate that the number of words depends on the real finished product.

ID NO. "X"

Manufacturer's code.
 It is accurate that the number of words depends on the real finished product.

200%

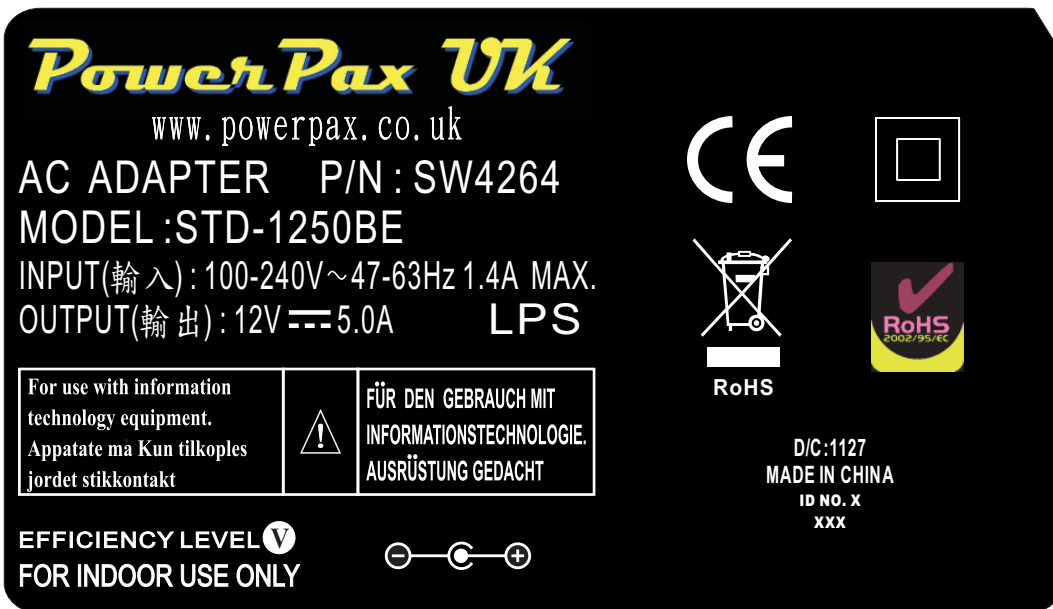

Label Part No.: 9443028320

8.8 Spec. Label Materials : Art paper (With Gloss)
Color : White Background with Black Printing
Label Dimension : 85.0mm(L)*15.0mm(W)+/-0.1mm
Label Thickness : 0.1mm

100%

P/N : SW4264

200%

P/N : SW4264

Label Part No.: 9443028330

A. Line Regulation Test

Test Result :

Test condition	Spec.	Reading 1	Reading 2	Reading 3
90Vac / 50 % Load	11.40 V ~ 12.60 V	11.872 V	12.103 V	12.076 V
115Vac / 50 % Load	11.40 V ~ 12.60 V	11.872 V	12.103 V	12.076 V
132Vac / 50 % Load	11.40 V ~ 12.60 V	11.872 V	12.103 V	12.076 V
180Vac / 50 % Load	11.40 V ~ 12.60 V	11.872 V	12.103 V	12.076 V
230Vac / 50 % Load	11.40 V ~ 12.60 V	11.872 V	12.103 V	12.076 V
264Vac / 50 % Load	11.40 V ~ 12.60 V	11.872 V	12.103 V	12.076 V

B. Efficiency Test

Test Result :

Test condition	Spec.	Reading 1	Reading 2	Reading 3
115Vac / 100% Load	87 % Min.	87.76 %	87.28 %	87.19 %
230Vac / 100% Load	87 % Min.	88.26 %	87.58 %	87.48 %

$$\text{Eff (av)} = \frac{E_1 + E_2 + E_3 + E_4}{4}$$

E1=efficiency with 25% rated load ; E2= efficiency with 50% rated load
E3=efficiency with 75% rated load ; E4= efficiency with 100% rated load

C. Load Regulation Test

Test Result :

Test condition	Spec.	Reading 1	Reading 2	Reading 3
115Vac / 0 % Load	11.40 V ~ 12.60 V	12.113 V	12.252 V	12.241 V
115Vac / 50 % Load	11.40 V ~ 12.60 V	12.872 V	12.103 V	12.076 V
115Vac / 100 % Load	11.40 V ~ 12.60 V	11.750 V	11.931 V	11.893 V
230Vac / 0 % Load	11.40 V ~ 12.60 V	12.113 V	12.252 V	12.241 V
230Vac / 50 % Load	11.40 V ~ 12.60 V	12.872 V	12.103 V	12.076 V
230Vac / 100 % Load	11.40 V ~ 12.60 V	11.750 V	11.931 V	11.893 V

D. Ripple & Noise Test

Test Result :

Test condition	Spec.	Reading 1	Reading 2	Reading 3
115Vac / 100 % Load	120 mV Max.	70.0 mV	76.0 mV	73.0 mV
230Vac / 100 % Load	120 mV Max.	60.0 mV	65.0 mV	64.0 mV

E. Inrush Current

Test Result :

Test condition	Spec.	Reading 1	Reading 2	Reading 3
230Vac / 100 % Load	80 A Max	43.8 A	44.2 A	42.7 A

F. Over Current Protection

Test Result :

Test condition	Spec.	Reading 1	Reading 2	Reading 3
115Vac / 100 % Load	Iout*(105%~180%)	145 %	146 %	143 %
230Vac / 100 % Load	Iout*(105%~180%)	148 %	150 %	147 %

G. Short Circuit Protection

Test Result :

Test condition	Spec.	Reading 1	Reading 2	Reading 3
115Vac / 100 % Load	Auto Recovery	OK	OK	OK
230Vac / 100 % Load	Auto Recovery	OK	OK	OK

H. Input Power Consumption(No Load)

Test Result :

Test condition	Spec.	Reading 1	Reading 2	Reading 3
230Vac / 0 % Load	≤ 0.5 W	0.25 W	0.32 W	0.31 W

Efficiency Test Report

- A. **Model Number** : STD-1250BE (12.0V / 5.0A)
- B. **DC Power Cord** : UL1185 , 16AWG , 1.5M
- C. **Average Efficiency** :
- Energy Star V : 87% min.
- Erp (Stage 2) : 87% min.
- MEPS V : 87% min.
- D. **NO Load Power Consumption** :
- Energy Star V : 0.5W max.
- Erp (Stage 2) : 0.5W max.
- MEPS V : 0.5W max.
- E. **Testing Dequipment** :
1. AC Power Source : " Zentech " 2700M-10
2. Electronic Load : " PRODIGIT " 3311D
3. Power Meter : " iDRC " CP-290
4. Digital Meter : " FLUKE " 179
- F. **AC Input Voltage** : 115Vac/60Hz

Load Conditions Reported Quantity	100%* I ₀	75%* I ₀	50%* I ₀	25%* I ₀	0%* I ₀
Rms Output Current(mA)	5000mA	3750mA	2500mA	1250mA	0mA
Rms Output Voltage(V)	11.770V	11.870V	11.980V	12.090V	12.220V
Active Output Power(W)	58.85W	44.51W	29.95W	15.11W	0.00W
Rms Input Voltage(V)	115V	115V	115V	115V	115V
Rms Input Current(A)	1.252A	0.950A	0.653A	0.348A	0.015A
Rms Input Power(W)	68.90W	51.20W	34.00W	17.10W	0.20W
Voltage T.H.D.(%)	0.27%	0.25%	0.19%	0.14%	0.10%
True Power Factor	0.478	0.467	0.452	0.427	0.117
Power Consumed by UUT(W)	10.05W	6.69W	4.05W	1.99W	0.20W
Efficiency	85.41%	86.94%	88.09%	88.38%	*
Average Efficiency	87.20%				*

- G. **AC Input Voltage** : 230Vac/50Hz

Load Conditions Reported Quantity	100%* I ₀	75%* I ₀	50%* I ₀	25%* I ₀	0%* I ₀
Rms Output Current(mA)	5000mA	3750mA	2500mA	1250mA	0mA
Rms Output Voltage(V)	11.770V	11.880V	11.970V	12.080V	12.230V
Active Output Power(W)	58.85W	44.55W	29.93W	15.10W	0.00W
Rms Input Voltage(V)	230V	230V	230V	230V	230V
Rms Input Current(A)	0.630A	0.482A	0.337A	0.402A	0.023A
Rms Input Power(W)	68.00W	50.60W	34.00W	17.20W	0.20W
Voltage T.H.D.(%)	0.37%	0.31%	0.44%	0.16%	0.12%
True Power Factor	0.469	0.456	0.439	0.402	0.038
Power Consumed by UUT(W)	9.15W	6.05W	4.08W	2.10W	0.20W
Efficiency	86.54%	88.04%	88.01%	87.79%	*
Average Efficiency	87.60%				*

Tester : Jarvis

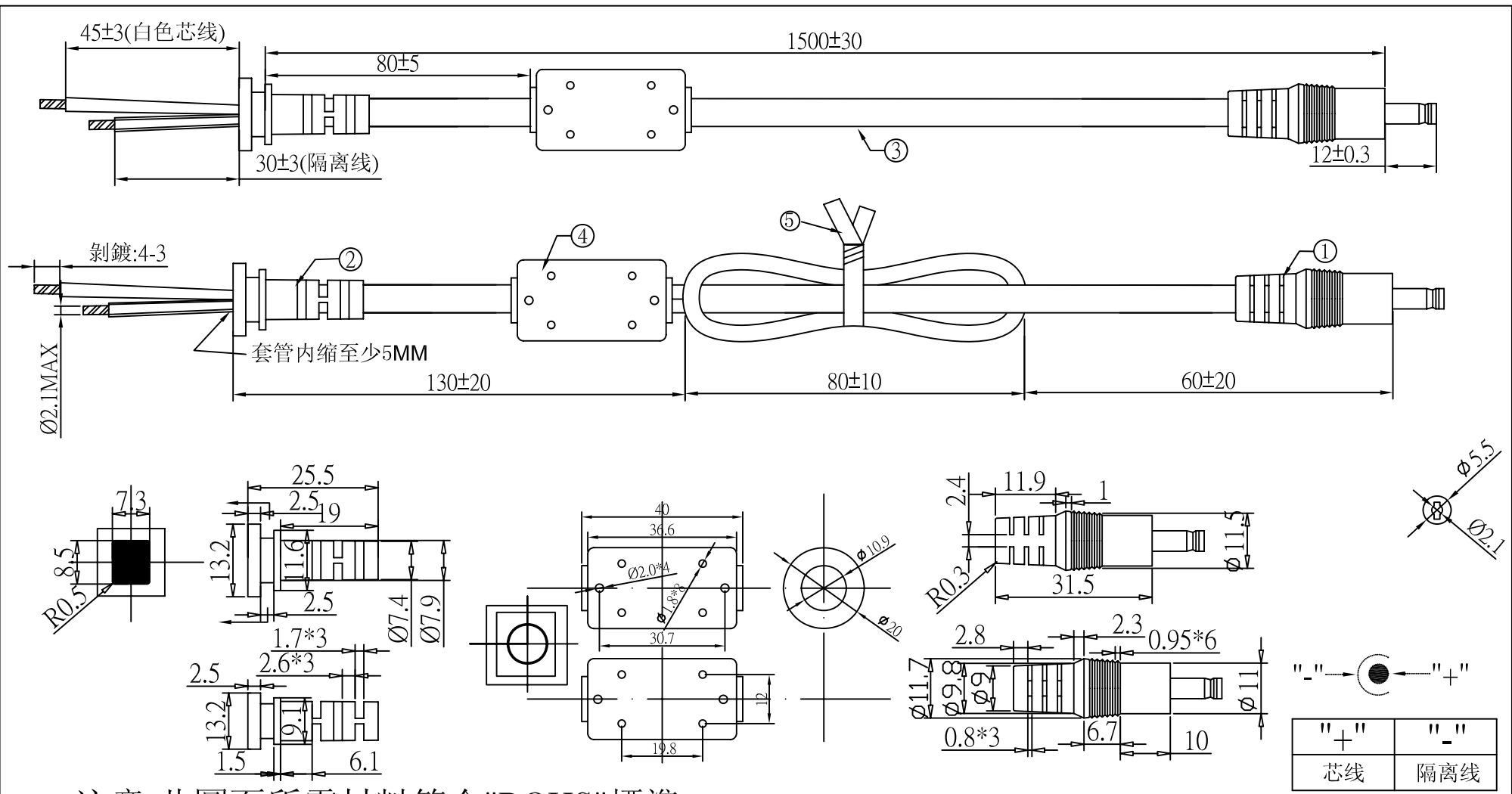

注意:此圖面所需材料符合"ROHS"標準

- ① 5.5*2.1*23音叉車溝黑色半邊(YYPD-00186),外模P-184號模(二次成型),用料外PVC60P黑色(YYPV-00009)
- ② SR-348(C)號模,用料PVC75P黑色(YYPV-00031),吊重:1米/20磅/60秒
- ③ UL 1185 16AWG(0.254*26) 单芯隔离线加粗 (0.16*65) BK亮 OD:4.3 裁線長度:1560+10/-0
- ④ 鐵芯規格:14.2*28.5*6.35(YYCR-00009),外模SR-118號模用料PVC60P黑色(YYPV-00009)
- ⑤ 热缩套管Ø2*35
- ⑥ PE有鐵芯紫帶10CM黑色(YYES-00001)
- ⑦ 絕緣阻抗:20Ω,導通阻抗:1.5Ωmax
- ⑧ 單位:MM

料號	R44M1115017		
客戶	阿達特	制圖	吴远松
版次	02	審核	
頁數	01	批準	
泰岳電子有限公司			
圖號	ADT-1797	日期	2011/04/21

版次	變更內容
02	鍍錫OD

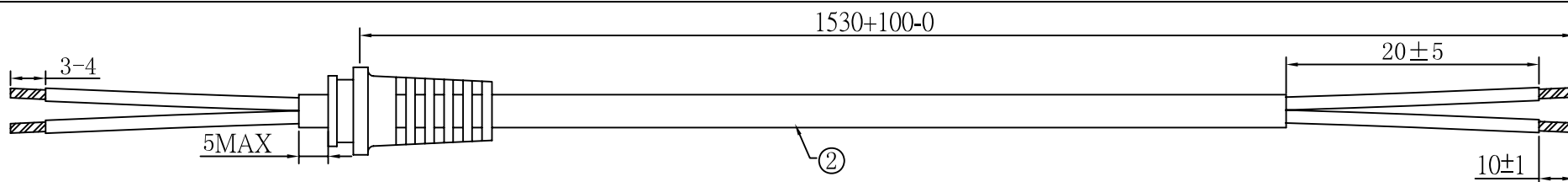

注:此图面所用材料需符合ROHS标准

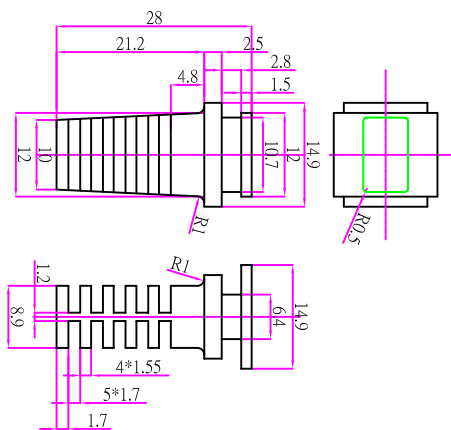
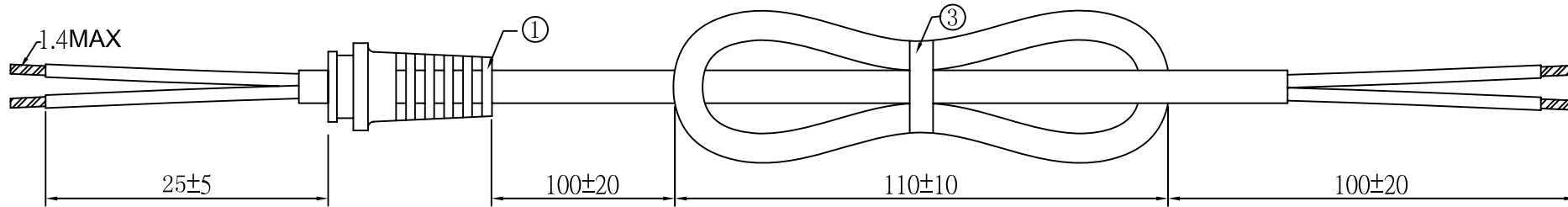

- ① SR-476號模,用料PVC60P黑色,吊重:1米/35磅/60秒
- ② H03線 VVH2-F 2*0.75MM²*2C OD:3.4*5.6 BK 裁線長度:1600+10-0 (钢板印字)吊重:1米/35磅/60秒)
- ③ PE有芯扎帶12CM黑色
- ④ 導通阻抗:25Ω/KM Max,最高電壓:300V
- ⑤ 單位:MM

料號	R42GAJ15311		
客戶	阿达特	制圖	吴远松
版次	01	初審	
頁數	01	審核	
		批準	
泰岳电子有限公司			
圖號	ADT-2092	日期	2011/07/28

Printing ROHS in the middle of the PE bubble bag

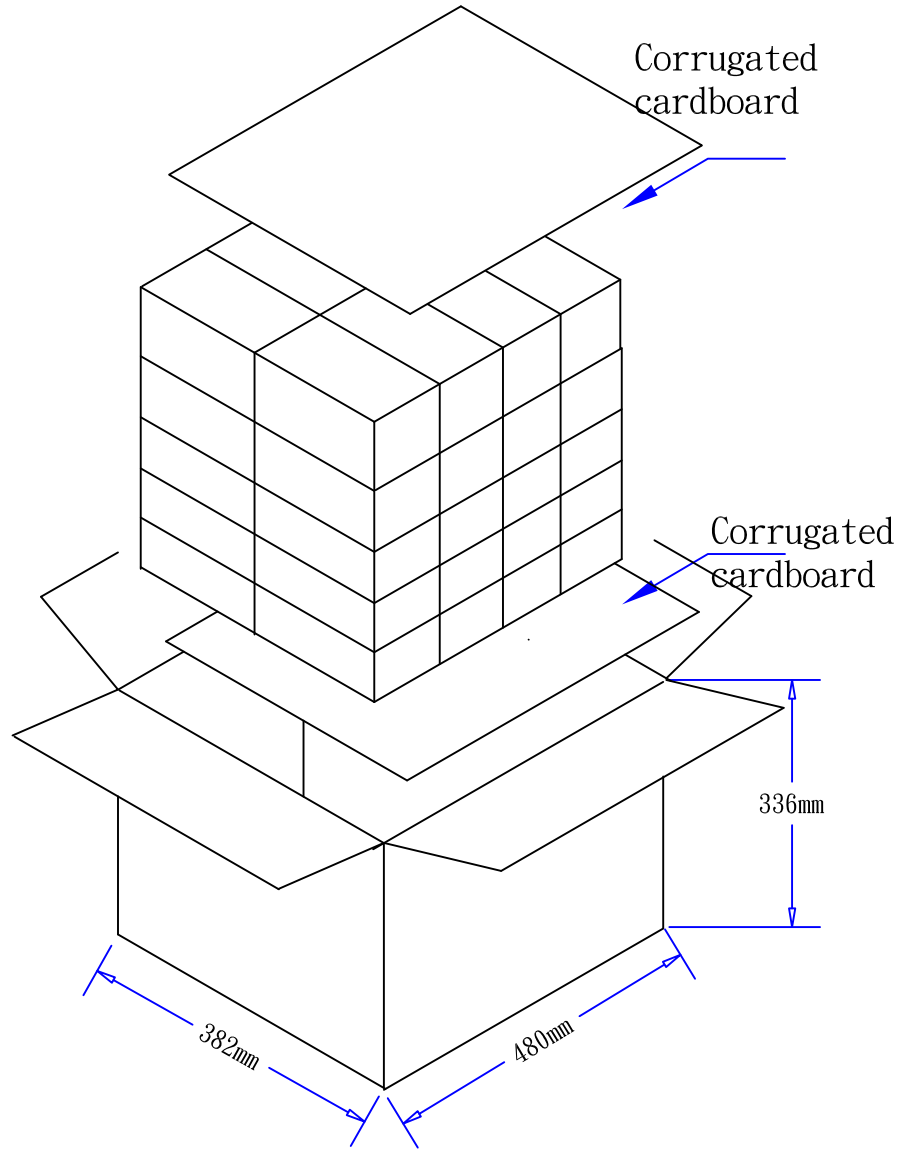
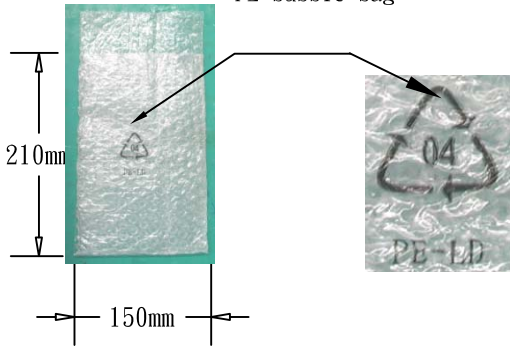

White box

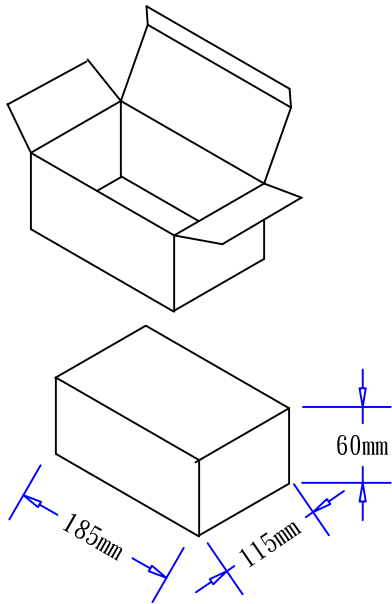

1. Corrugated cardboard: 465*370*6mm B=B 2/40
2. Q' ty: 8*5=40PCS
3. Master carton: L*W*H=480*382*336mm K=K 1/40
4. White box: L*W*H=185*115*60mm 350P+CE
5. PE bubble bag :210*150*47mm: No color/Clear bag
6. When finished product into the PE bubble bag .affies it by a clear tap,
7. carton, box marks with dimension and ROHS compliance

DRAWING NO.		PIS40W00001	APPROVAL2	
UNIT	MODEL NO.	40-65W掛壁式白盒	APPROVAL1	
mm	FILE	ADT-0081	ENGINEER	
SCALE	REV.	B	SHEET	1/1
			DRAWN BY	sun