

Transistor, PNP TO-3



Description:

Silicon power transistors.

The MJ15023 power transistors designed for high power audio, disk head positioners and other linear applications.

Features:

- High safe operating area (100% tested) - 2A at 80V
- High DC current gain = $h_{FE} = 15$ (min.) at $I_C = 8A$ DC
- Pb-free packages

Maximum Ratings

Rating	Symbol	Value	Unit
Collector-Emitter Voltage	V_{CEO}	200	V DC
Collector-Base Voltage	V_{CBO}	350	
Emitter-Base Voltage	V_{EBO}	5	
Collector-Emitter Voltage	I_{CEX}	400	A DC
Collector Current - Continuous - Peak (Note 1)	I_C	16 30	
Base Current-Continuous	I_B	5	
Total Power Dissipation at $T_C = 25^\circ C$ Derate above $25^\circ C$	P_D	250 1.43	W W/ $^\circ C$
Operating and Storage Junction Temperature Range	T_J, T_{Stg}	-65 to +200	$^\circ C$

Thermal Characteristics

Characteristic	Symbol	Max.	Unit
Thermal Resistance Junction to Case	$R_{\theta JC}$	0.7	$^\circ C/W$

Max. ratings are those values beyond which device damage can occur. Maximum ratings applied to the device are individual stress limit values (not normal operating conditions) and are not valid simultaneously. If these limits are exceeded, device functional operation is not implied, damage may occur and reliability may be affected.

1. Pulse Test: Pulse Width = 5ms, Duty Cycle $\leq 10\%$

Transistor, PNP TO-3



Electrical Characteristics ($T_C = 25^\circ\text{C}$ unless otherwise noted)

Characteristic	Symbol	Min	Max	Unit
----------------	--------	-----	-----	------

Off Characteristics

Collector-Emitter Sustaining Voltage (Note 2) ($I_C = 100\text{mA DC}$, $I_B = 0$)	$V_{CEO(sus)}$	200	-	-
Collector Cut off Current ($V_{CE} = 200\text{V DC}$, $V_{BE(off)} = 1.5\text{V DC}$)	I_{CEX}	-	250	$\mu\text{A DC}$
Collector Cut off Current ($V_{CE} = 150\text{V DC}$, $I_B = 0$)	I_{CEO}	-	500	
Emitter Cut off Current ($V_{CE} = 5\text{V DC}$, $I_B = 0$)	I_{EBO}	-		

Second Breakdown

Second Breakdown Collector Current with Base Forward Biased ($V_{CE} = 50\text{V DC}$, $t = 0.5\text{s}$ (Non-repetitive)) ($V_{CE} = 80\text{V DC}$, $t = 0.5\text{s}$ (Non-repetitive))	$I_{S/b}$	5 2	- -	A DC
---	-----------	--------	--------	------

On Characteristic

DC Current Gain ($I_C = 8\text{A DC}$, $V_{CE} = 4\text{V DC}$) ($I_C = 16\text{A DC}$, $V_{CE} = 4\text{V DC}$)	h_{FE}	15 5	60 -	-
Collector-Emitter Saturation Voltage ($I_C = 8\text{A DC}$, $I_B = 0.8\text{A DC}$) ($I_C = 16\text{A DC}$, $I_B = 3.2\text{A DC}$)	$V_{CE(sat)}$	-	1.4 4	V DC
Base-Emitter On Voltage ($I_C = 8\text{A DC}$, $V_{CE} = 4\text{V DC}$)	$V_{BE(on)}$	-	2.2	

Dynamic Characteristics

Current-Gain Bandwidth Product ($I_C = 1\text{A DC}$, $V_{CE} = 10\text{V DC}$, $f_{test} = 1\text{MHz}$)	f_T	4	-	MHz
Output Capacitance ($V_{CB} = 10\text{V DC}$, $I_E = 0$, $f_{test} = 1\text{MHz}$)	C_{OB}	-	600	pF

1. Pulse Test: Pulse Width = $300\mu\text{s}$, Duty Cycle $\leq 2\%$

Transistor, PNP T0-3



Active Region DC Safe Operating Area

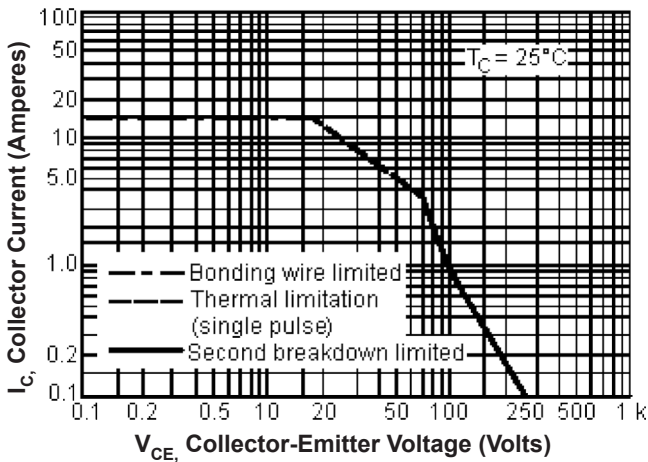

There are two limitations on the power handling ability of a transistor: average junction temperature and second breakdown. Safe operating area curves indicate $I_C - V_{CE}$ limits of the transistor that must be observed for reliable operation; i.e., the transistor must not be subjected to greater dissipation than the curves indicate.

The data is based on $T_{J(pk)} = 200^\circ\text{C}$; T_C is variable depending on conditions. At high case temperatures, thermal limitations will reduce the power that can be handled to values less than the limitations imposed by second breakdown.

Capacitances

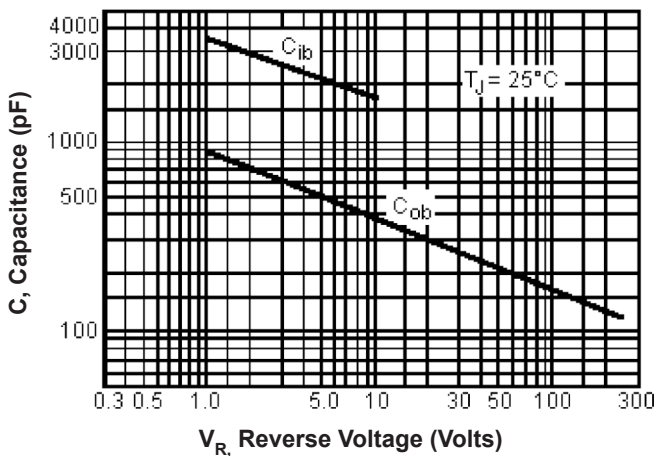

Current - Gain - Bandwidth Product

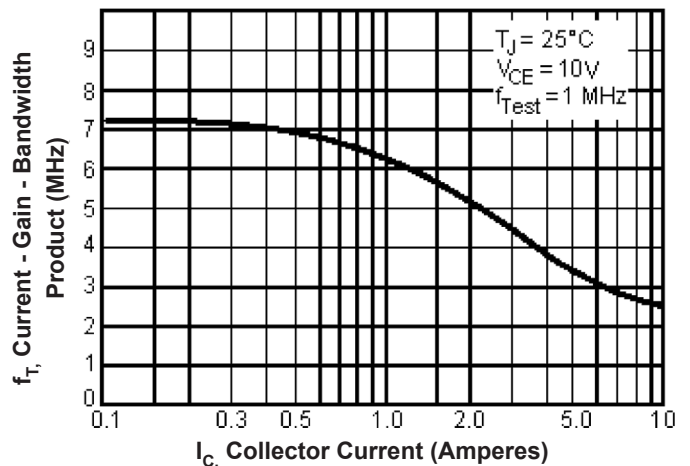

DC Current Gain

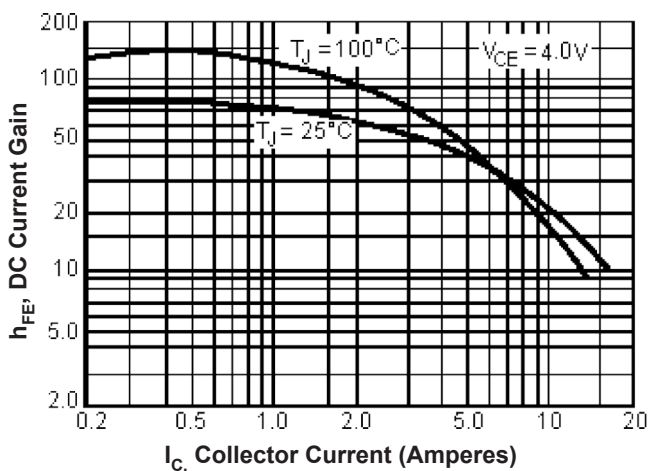

"On" Voltages

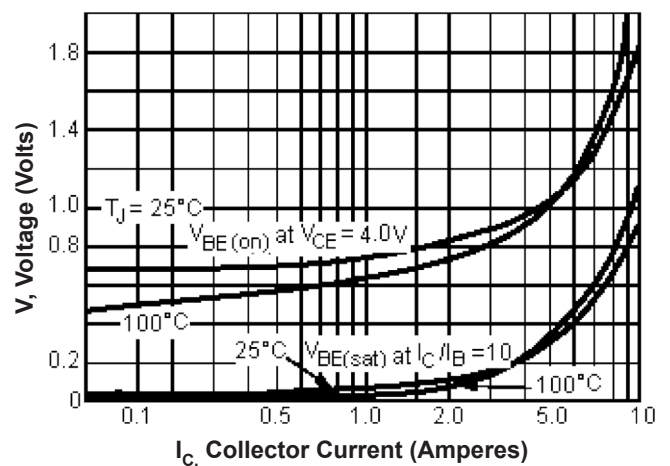

Transistor, PNP TO-3



Dimensions

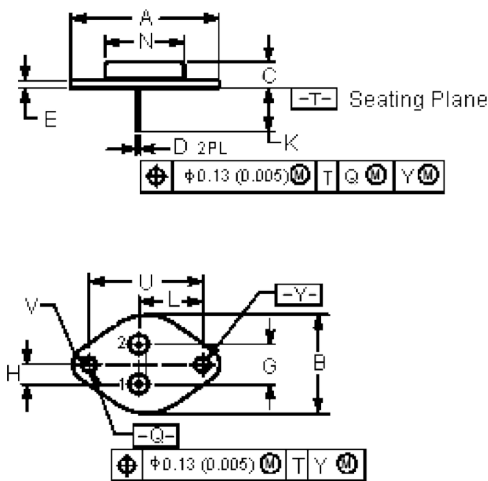

Dimensions	Min.	Max.
A	1.55 (39.37)	Reference
B	-	1.05 (26.67)
C	0.25 (6.35)	0.335 (8.51)
D	0.038 (0.97)	0.043 (1.09)
E	0.055 (1.4)	0.07 (1.77)
G	0.43 (10.92)	BSC
H	0.215 (5.46)	BSC
K	0.44 (11.18)	0.48 (12.19)
L	0.665 (16.89)	BSC
N	-	0.83 (21.08)
Q	0.151 (3.84)	0.165 (4.19)
U	1.187 (30.15)	BSC
V	0.131 (3.33)	0.188 (4.77)

Dimensions : Inches (Millimetres)

Pin Configuration

- Pin 1. Base
- 2. Emitter
- Collector (Case)

Part Number Table

Description	Part Number
Transistor, PNP, TO-3	MJ15023

Important Notice : This data sheet and its contents (the "Information") belong to the members of the Premier Farnell group of companies (the "Group") or are licensed to it. No licence is granted for the use of it other than for information purposes in connection with the products to which it relates. No licence of any intellectual property rights is granted. The Information is subject to change without notice and replaces all data sheets previously supplied. The Information supplied is believed to be accurate but the Group assumes no responsibility for its accuracy or completeness, any error in or omission from it or for any use made of it. Users of this data sheet should check for themselves the Information and the suitability of the products for their purpose and not make any assumptions based on information included or omitted. Liability for loss or damage resulting from any reliance on the Information or use of it (including liability resulting from negligence or where the Group was aware of the possibility of such loss or damage arising) is excluded. This will not operate to limit or restrict the Group's liability for death or personal injury resulting from its negligence. Multicomp is the registered trademark of the Group. © Premier Farnell plc 2012.

