

OPER

TOOLS

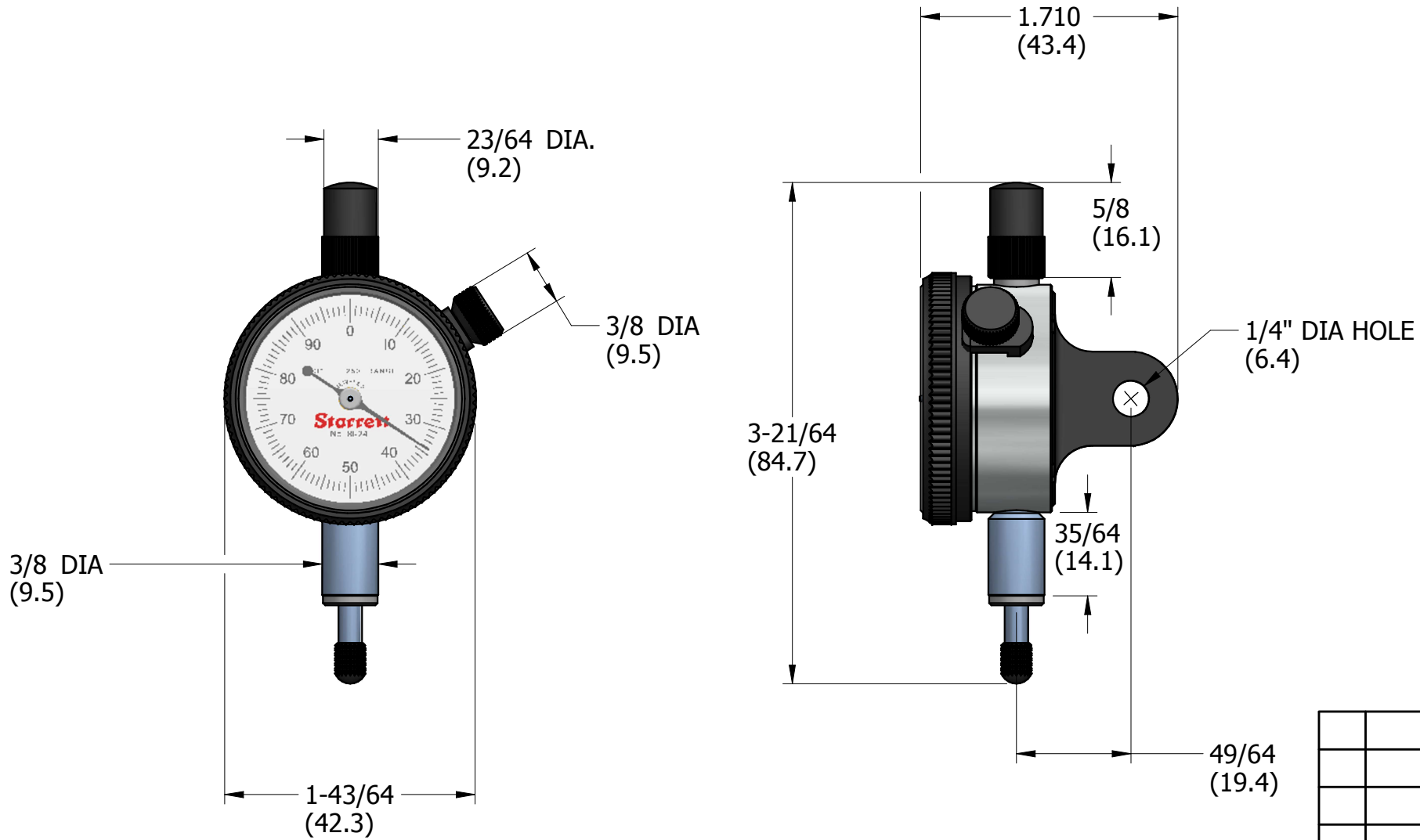

REV	DESCRIPTION	DATE	BY
-----	-------------	------	----

DR	PRT	CHK	DATE
----	-----	-----	------

DIAL INDICATOR

FRACTIONAL TOLERANCE +- 1/64 UNLESS OTHERWISE NOTED

THE L.S. STARRETT CO.  
ATHOL, MASS.