

PH-100A

Please read the entire instruction manual thoroughly before initial set-up and operation; the information contained herein will aid you in operating PH-100A tachometer safely and with excellent results.



Inspection/Standard Accessories

If upon delivery shipping damage is detected, do not operate the TACHOMETER. Notify shipping carrier immediately for damage claim instructions. Refer to nameplate and record the serial number for future reference. Items included with the PH-100A are:

- Carrying case
- 3 manganese AA batteries
- Cone adapter
- Funnel adapter
- 6" circumference wheel
- Certificate of calibration
- Instruction manual pieces

Features and Benefits

PH-100A tachometer incorporates the latest microprocessor technology and offers:

- Multiple measurement types: total revolutions (rev); revolutions per minute (rpm); surface speed: m/min, y/min, in/min, ft/min; and length: meters, yards, feet and inches.
- Compact, pocket-size design
- 14 reading memory: minimum, maximum, final, 10 selectable measurements and an average of memory measurements, up to ten.
- Energy-saving design allows long battery life and continuous operation.
- The tachometer automatically converts between units of measurements by pressing the UNIT button.

Important Safety Instructions

- Read entire instruction manual before using this tachometer.
- Be sure to store this manual in a safe place.
- When using the master wheel, do not use an extension shaft as the wheel may come off of the shaft and cause damage or injury.
- Although the tachometer is able to achieve higher measurements than what is listed, the master wheel has a maximum speed limitation of 1500 m/min (for safety reasons).

Display

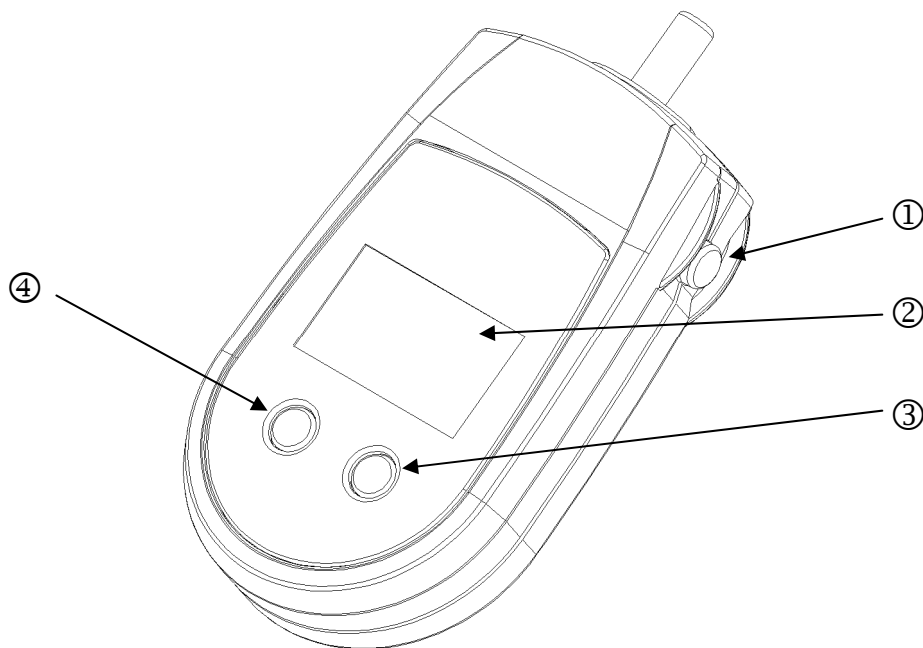

- (1) POWER switch: Turns the tachometer on and records measurements.
- (2) Display section: Displays measurements
- (3) UNIT switch: Selects the type of measurement to be made
- (4) MEM switch: Stores and cycles through memory.
- (5) Cone adapter (Not shown): Used for Contact rpm and rev measurements
- (6) Funnel adapter (Not shown): Used for Contact rpm and rev measurements.
- (7) 6" Circumference Wheel (Not shown): Used for Contact surface speed and length measurements.

Dimensions

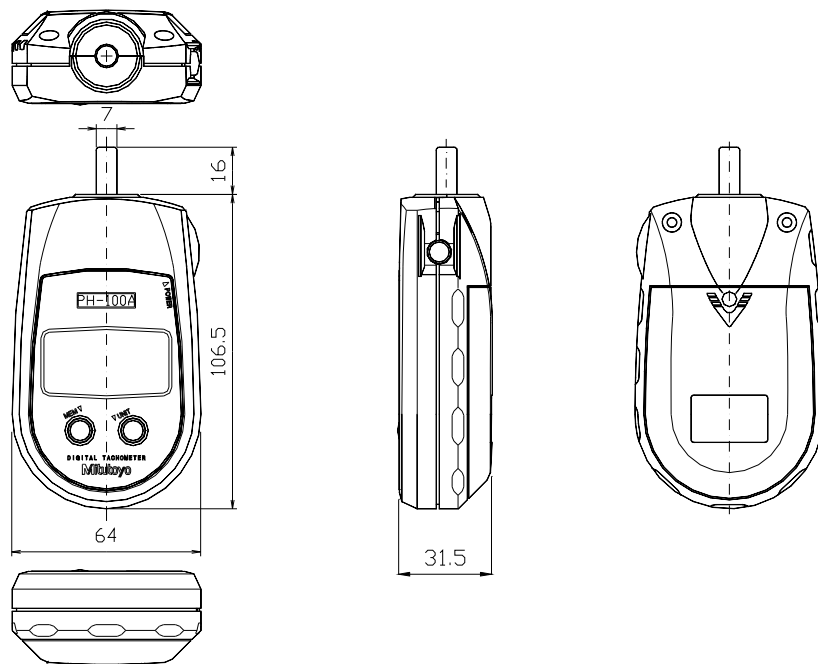

Standard Accessories

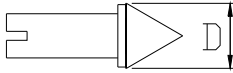
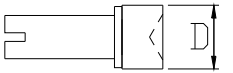
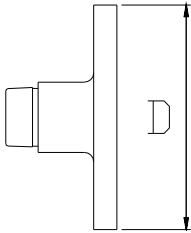
Description	Dimension	Drawing
Cone Adapter, Standard	D = 12.5mm	
Funnel Adapter, Standard	D = 12.5mm	
Master Wheel FPM (6" cir)	D = 48.53mm	

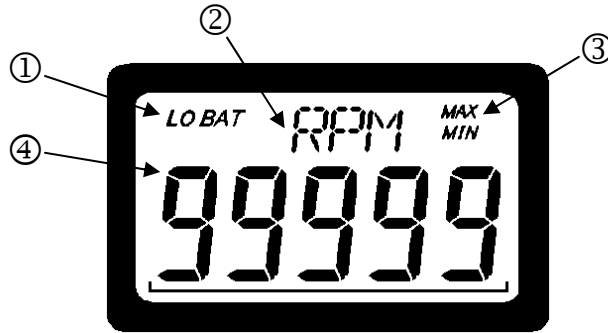

- ① Low battery display: When the battery is weak, "LO BAT" will flash.
- ② Tachometer's display: Displays measuring units.
- ③ Max/Min display: Displays minimum and maximum value.
- ④ Main display: 5 digit LCD displays measurement readings

Operation

Contact measurements

Measuring rotation speed using the cone or funnel-shaped contact probe.

1. Select the cone or funnel adapter and slide it onto the end of the shaft. Align the notch in the cone/funnel adapter with the alignment pin on the shaft.
2. Press the POWER button on the side of the tachometer, the LCD display will turn on.
3. Select "RPM" or "REV" depending on whether you wish to measure revolutions per minute or total number of revolutions by pressing the UNIT button.
4. Press and hold down the POWER button to start measuring.
5. Bring the contact probe into contact with the object to be measured by touching the contact probe slowly to the center of the rotating object. Note: If the measuring range of the tachometer is exceeded, "OVR" will appear on the tachometer's display.
6. Press and hold the POWER button to take another measurement.
7. To convert the units of measurements between ranges, simply press the UNIT button.
8. The POWER will automatically turn off after five minutes if there are no additional measurements made.

Caution: When a high-speed rotating object is measured for hours using a cone or funnel-shaped contact probe the surface of the probe in contact with the object may become very hot.

Measuring surface speed and distance using the master 6" circumference wheel.

1. Attach the 6" circumference wheel to the contact shaft insuring that the alignment pin on the shaft is securely aligned with the notch of the 6" circumference wheel.
2. Press the POWER button on the side at the tachometer, the LCD display will turn on.
3. Select meters/minute [m/M], yards/minute [Y/M], inches/minute [I/M], feet/minute [F/M], meters [m], yards [YRd], inch [IN], or feet [FT] depending on which units you wish to measure by pressing the UNIT button.
4. Bring the 6" circumference wheel into contact with the object to be measured by slowly touching the contact wheel to the moving object.
5. Press and hold down the POWER button to start measuring.
6. Release the POWER button to stop measuring.
7. To convert the units of measurements between ranges, simply press the UNIT button.

Caution: When making surface speed or distance measurements, insure that the 6" circumference wheel's perimeter is parallel to the object to be measured. Do not push the wheel against the object with great force.

Note: When using the master wheel, accuracy can be affected as much as 0.4% of reading.

MEMORY FUNCTION

This tachometer's memory capabilities include minimum, maximum, last measurement, 10 selectable measurements and an average of the memory measurements.

1. Minimum, maximum and last measurements are recorded automatically by the tachometer.
2. Ten selectable measurements can be programmed into memory by pressing the MEM button while the POWER button is fully depressed (M1, M2, M3, ... M10).
3. The average value of sequentially stored memory, up to ten, can be viewed by pressing the memory button.

Note: if the memory button (MEM) is not selected while the POWER button is pressed the measurement will not be recorded into its memory location, The memory will be recorded automatically into memory if the measurement made is the maximum, minimum or last measurement.

To delete stored memories do one of the following:

1. Press the MEM button for five seconds or more. All memory will be erased after [CCCCC] is displayed.
2. Changing the units of measurements and then making additional measurements.
3. Memory will be automatically erased if the TACHOMETER turns off automatically after five minutes.

BATTERY REPLACEMENT

When "LO BAT" flashes on the display, replace the batteries with new ones.

To replace the batteries, slide the battery cover located on the rear of the tachometer. Remove the old batteries and insert three new batteries while observing proper polarity. Replace the rear cover of the tachometer (dispose of old batteries properly).

Notes:

1. Do not mix old and new batteries.
2. When replacing the batteries, use AA batteries.
3. The Tachometer may be damaged if liquid leaks from the batteries. This may happen if the batteries are left inside the tachometer's enclosure for long periods of time. Remove the batteries after using the tachometer, and store them in the carrying case.

Troubleshooting

No Display:

- Confirm that the POWER button is operating properly.
- Confirm that the batteries are functioning properly and that they are inserted into the tachometer with correct polarity.

Specifications

Model		PH-100A
Display		5 digit 12 mm height LCD
Revolutions per Minute	(rpm)	1.0 - 25,000
Surface Speed (Using 6" Wheel)	(m/min)	0.1 - 3,809.8
	(yards/min)	0.1 - 4,166.4
	(inch/min)	3 - 99,999
	(feet/min)	0.2 - 12,499
Length (Using 6" Wheel)	(m)	0.01 - 99,999
	(yards)	0.01 - 99,999
	(feet)	0.1 - 99,999
	(inch)	1 - 99,999
Total number of revolutions	(rev)	0.1 - 99,999
Measuring Accuracy	Revolution	1.0 - 599.9 rpm: ± 1 rpm, 600 - 25,000 rpm: $\pm 0.006\%$ and ± 0.5 digit
	Surface Speed, Length	0.4% and ± 1 digit
Memory function		14 readings are stored in memory and retained for 5 minutes (Last, Max., Min., Average, and 10 selectable measurements)
Update Time		1 second
Detection		Optical coupler, 20 pulses per revolution
Auto POWER Off function		5 minutes
Batteries Included		3 AA 1.5V
Low Battery Indicator		Flashing "LO BAT" display
Over Range Indicator		Flashing "OVR" display
Operating Temperature		0 - 45°C
Construction		ABS resin
Outside dimensions		122.5 mm L x 64 mm W x 31.5 mm H
Weight		0.37 lb (170 g)(including batteries)
Accessories		Carrying Case, Cone Adapter, Funnel Adapter, Master Wheel (6" cir.), Certificate of calibration, Operation Instructions

Manufactured by

NIDEC-SHIMPO CORPORATION

1 Terada, Kohtari, Nagaokakyo-city, Kyoto, 617-0833 Japan

Phone: +81-(0)75-958-3608 Fax: +81-(0)75-958-3647