

AFM Series



GREEN XP POWER

- Energy Efficiency Level V
- CEC2008 & EISA2007 Compliant
- IT & Medical Approvals
- Optional Class II Versions
- 0 °C to +70 °C Operating Temperature
- Optional IEC320-C6 Inlet
- 3 Year Warranty

Specification

Input

Input Voltage	• 80-264 VAC, derate output power 25% <90 VAC
Input Frequency	• 47-63 Hz
Input Current	• AFM30: 0.8 A rms at 115VAC, AFM45: 1.2 A rms at 115VAC, AFM60: 1.5 A rms at 115 VAC
Power Factor	• EN61000-3-2, class A
Earth Leakage Current	• 150 μ A max at 264 VAC/60 Hz
No Load Input Power	• AFM30/45: <0.3 W, AFM60: <0.5 W

Output

Output Voltage	• See table
Output Voltage Trim	• Not user-adjustable
Initial Set Accuracy	• \pm 2%
Minimum Load	• No minimum load required
Start Up Delay	• 3 s max at 115 VAC
Hold Up Time	• 8 ms minimum at 115 VAC
Line Regulation	• \pm 1.0% maximum
Load Regulation	• 2.5% maximum
Transient Response	• 4% max. deviation, recovery to within 1% in 500 μ s for a 25% load change
Ripple & Noise	• 1% max pk-pk (see note 1)
Overvoltage Protection	• 110-170% Vnom, recycle input to reset
Overload Protection	• AFM45/60: 110-170%, AFM30: 110-220%, auto recovery
Short Circuit Protection	• Trip and restart (hiccup mode)
Temperature Coefficient	• 0.04%/°C

General

Efficiency	• See table
Energy Efficiency	• Level V
Isolation	• 4000 VAC Input to Output 1500 VAC Input to Ground Output 0 V is electrically connected to Input Ground
Switching Frequency	• 65-100 kHz variable
Power Density	• AFM30: 2.8 W/in ³ , AFM45: 4.2 W/in ³ , AFM60: 3.76 W/in ³
MTBF	• >250 kHrs to MIL-HDBK-217F at 25 °C, GB, full load

Environmental

Operating Temperature	• 0 °C to +70 °C, derate from 100% power at +40 °C to 60% power at +70 °C
Operating Humidity	• 10-95% RH, non-condensing
Storage Temperature	• -40 °C to +80 °C
Operating Altitude	• 3000 m
Shock	• 30 g, 10 ms on 3 axes
Vibration	• 5-100 Hz, 2.31 m/s ² , 20 mins, 3 axes

EMC & Safety

Emissions	• EN55011/22/FCC Class B conducted, EN55011/22/FCC Class B radiated
Harmonic Currents	• EN61000-3-2, Class A
Voltage Flicker	• EN61000-3-3
ESD Immunity	• EN61000-4-2, 6 kV contact and 8 kV air discharge
Radiated Immunity EFT/Burst	• EN61000-4-3, 3 V/m Perf Criteria A • EN61000-4-4, level 3 Perf Criteria A, (see note 7)
Surge	• EN61000-4-5, installation class 3 Perf Criteria A
Conducted Immunity Magnetic Field	• EN61000-4-6, 3 Vrms Perf Criteria A • EN61000-4-8, 3 A/m, Perf Criteria A
Dips & Interruptions	• EN61000-4-11, 30% for 10 ms, 60% 100 ms, 100% 5000 ms, Perf Criteria A, B, B • EN60601-1-2, 30% 500 ms, 60% 100 ms, 100% 10 ms, 100% 5000 ms, Perf A, A, A, B (see note 8)
Safety Approvals	• EN60950-1, UL60950-1, IEC60950-1 EN60601-1, UL60601-1 (2nd Edition), IEC60601-1

Models and Ratings

Output Power	Output Voltage ⁽⁵⁾	Output Current	Efficiency ⁽⁶⁾	Model Number ^(3,4)
30 W	12 V	2.50 A	87.9%	AFM30US12†^
30 W	15 V	2.00 A	88.4%	AFM30US15†^
30 W	18 V	1.67 A	87.6%	AFM30US18†^
30 W	24 V	1.25 A	88.0%	AFM30US24†^
48 W	12 V	4.00 A	87.7%	AFM45US12†^
48 W	15 V	3.20 A	88.0%	AFM45US15†^
48 W	18 V	2.67 A	87.2%	AFM45US18†^
48 W	24 V	2.00 A	87.7%	AFM45US24†^
60 W	12 V	5.00 A	87.3%	AFM60US12†^
60 W	15 V	4.00 A	88.2%	AFM60US15†^
60 W	18 V	3.34 A	88.3%	AFM60US18†^
60 W	24 V	2.50 A	87.8%	AFM60US24†^

Notes

1. Ripple and noise measured at 20 MHz bandwidth with a 10 µF tantalum and 0.1 µF ceramic cap connected at the measurement point.
 2. Total regulation includes initial set accuracy, line and load regulation.
 3. For optional Class II versions with a polarised IEC320-C8 inlet, add suffix 'C2' to the model number, e.g. AFM60US24C2.
 4. For alternative IEC320-C6 inlet, add suffix 'C6' to the model number eg. AFM60US24C6.
 5. Other output voltages are available, contact sales for details.
 6. Minimum average of efficiencies measured at 25%, 50%, 75% & 100% load.
 7. A minimum load of 1% is required to meet performance criteria A.
 8. Performance criteria given for high line input.
- † Available from Farnell & element14. See pages 284-290.
 ^ Available from Newark. See pages 291-296.

Mechanical Details

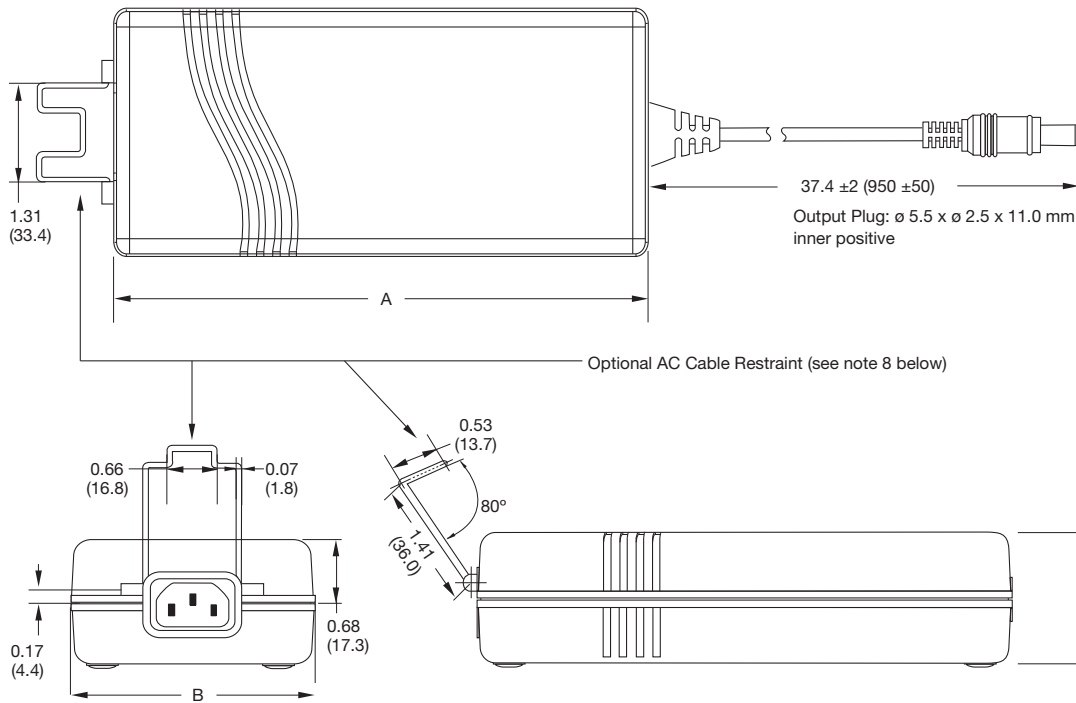

	AFM30 & 45	AFM60
A	4.76 (121.0)	4.92 (125.0)
B	1.97 (50.0)	2.44 (62.0)
C	1.21 (30.8)	1.33 (34.0)

Notes

1. All dimensions shown in inches (mm). Tolerance is 0.02 (0.5) maximum, except output cable length.
2. Weight: AFM45: 0.56 lbs (256 g), AFM60: 0.78 lbs (360 g) approx.
3. Case material is PC Class 94 V-0.
4. Output Lead: UL1185, 16 AWG
5. For European mains lead order part EU-MAINS-IEC for C14 versions, EU-MAINS-5 for C6 versions or EU-MAINS-8 for C8 versions.
6. For UK mains lead order part UK-MAINS-IEC for C14 versions, UK-MAINS-5 for C6 versions or UK-MAINS-8 for C8 versions.
7. For US mains lead order part US-MAINS-IEC for C14 versions, US-MAINS-5 for C6 versions or US-MAINS-8 for C8 versions.
8. For optional AC Cable Restraint on the standard input version add suffix 'A' to the model number e.g. AFM60US24A. AC Mains Lead must be Interpower Corporation, part number 70006020300. Option AC Cable Restraint is not available on IEC320-C6 inlet or Class II versions.