

Electronic Indicating Pressure Switch/Transmitter ce SERIES 800



Copyright

All rights to these operating instructions are reserved. These operating instructions, including extracts thereof, must not be copied or translated into other languages without our written permission.

Safety Instructions and Warnings

Please read these instructions before installing and starting up the pressure switch. Failure to follow the instructions will make all guarantee, warranty and compensation claims null and void.

- Only qualified persons are permitted to install the equipment and make the electrical connection, and the correct tools must always be used.
- The limits that are specified in the technical data for the pressure switch must be complied with.
- Please note that the pressure switch can be affected or damaged by strong magnetic fields, erroneous equipotential bonding or other effects.
- The device must not be opened, painted / coated or modified.
- Damaged devices must not be started up. If damage occurs during operation, suitable measures must be taken to prevent persons or property from being put at risk by the damaged pressure switch.
- The switch must only be repaired by NOSHOK.

The accepted technical regulations and all national guidelines must always be observed and complied with.

Exclusion of Liability

NOSHOK guarantees that the pressure switch is in perfect working condition when it is delivered. The basis consists of the technical data in the data sheet and these operating instructions. Liability cannot be accepted for the suitability of the pressure switch.

Pressure Switch Description

The pressure switch has one analog output and one switch output or two switch outputs. The analog output is calibrated in the factory, and the switch output(s) is (are) adjusted using the two buttons: set point, reset point(hysteresis / window), switching function (normally closed / normally open contact) and switching to N potential or P potential.

The password protection that can be activated is a special feature, and prevents unauthorized persons from modifying the adjusting parameters.

The optional dual rotating capability makes it possible for the electrical output and the display to be aligned independently.

Electrical and Mechanical Connection

The technical regulations must be complied with during installation and dismantling.

The system must be depressurized prior to installation and dismantling.

Safety regulations must be complied with, particularly when working on the electrical system. All connections to external electrical equipment must be made in accordance with regulations.

The power to system must always be switched off when the switch is being connected.

The load can be connected to ground (switching to P potential) or to the supply voltage (switching to N potential).

Round Connector M 12 x 1 (4-pin)

Signal	Connector	Colors of Optional Wires
Supply: +	1	brown
Supply: -	3	blue
Switch output S 1	4	black
Switch output S 2 or analog output	2	white

We recommend our accessories:

M12x1 socket with 2m cable

- straight version, order no.: FS-2-4P
 - angled version, order no.: FA-2-4P
- (4 and 6 meter cables also available)

switching to P potential

1 switching output and 1 analog output

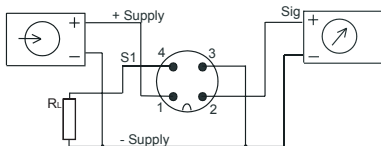

2 switching outputs

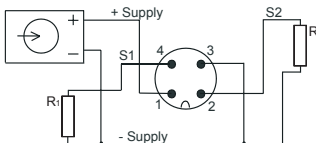

switching to N potential

1 switching output and 1 analog output

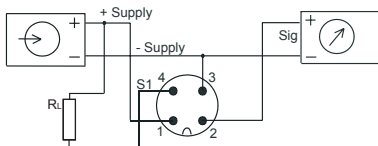

2 switching outputs

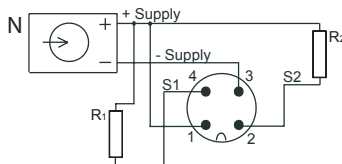

Switching On and Off

The pressure switch is switched on when the supply voltage is applied. There is no on/off switch. A brief initialization phase occurs when the supply voltage is applied to the switch. The switch is then in normal operating mode. The operating pressure is shown on the display and the switch outputs are operational. Briefly pressing button S1 causes the switching point 1 setting to be displayed, and pressing button S2 causes the second switching point to be displayed.

Programming

Pressing the buttons for longer (press and hold down button until display flashes) causes the current pressure to be taken over as the switching point. The hysteresis remains unchanged. If the password has been activated (see main programming mode) the programming is only accepted after the password has been entered.

The switch output(s) can be programmed using the control buttons without the presence of pressure. The programming sequence must run without interruptions. If delays of about 30 seconds occur, the switch automatically exits programming mode and switches to normal mode. All previous changes are lost.

Status-LED Switching Output



Password

Password protection can be activated in the main programming mode. The pressure switch is protected from unauthorized setting modifications.

If you forget the password, assistance can be obtained from NOSHOK.

The serial number of the pressure switch will be needed in this case (on the label).

Switching Points and Hysteresis / Window

The switching point(s) can also be programmed without the presence of pressure. The decimal points are specified in the factory in accordance with the measuring / adjusting range and the associated accuracy.

Switching Function

The switching function (normally closed / normally open contact) is defined individually for each switching point. Each switch output is programmed to switch to P potential or N potential.

Quick Programming - User Menu

Function of the buttons:

S1 to run through the menu points, to change the value

S2 to select menu point, to return to the menu point



= These steps are available on switches configured with the Enhanced Software Option Only.

*The parameters which are marked with a * can only be changed if the user is authorized in the set-up menu (CO.En). Otherwise, there will be only the display of the selected values in this menu.

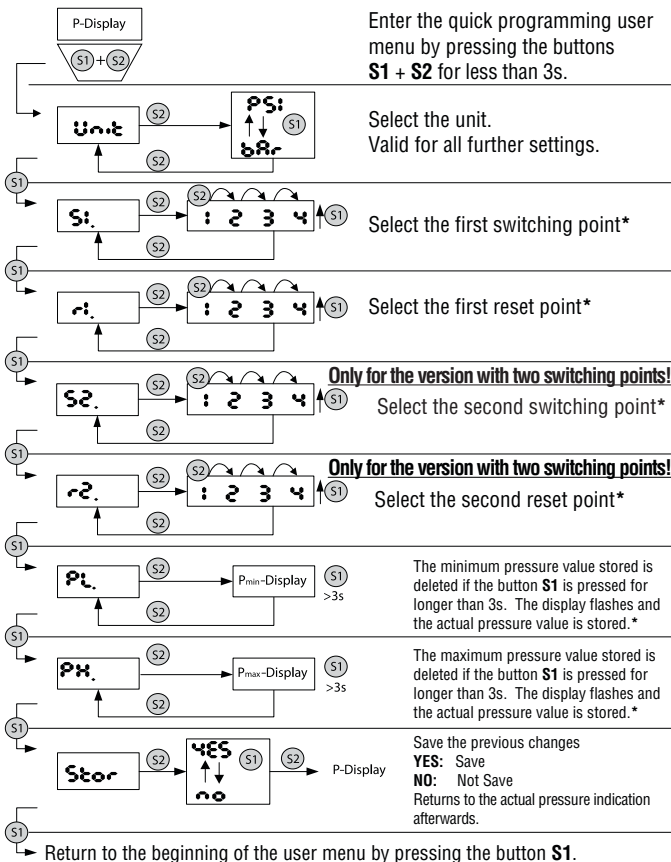

Main Programming - Set Up Menu

Function of the buttons:

S1 to run through the menu points, to change the value

S2 to select menu point, to return to the menu point



= These steps are available on switches configured with the Enhanced Software Option Only.

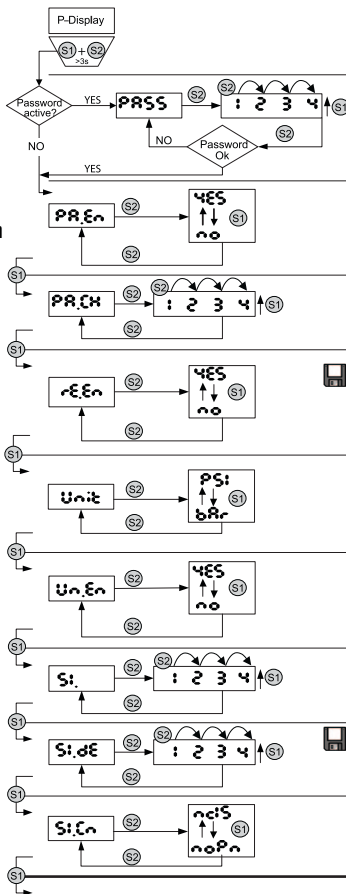

Enter the user menu by pressing the buttons **S1** + **S2** for at least 3s.

Only required for activated password. [PA.En]

Activate password.

YES: Password is required
NO: Password is not required

Change password.

Only possible with activated password. [PA.En]



Preset-authorization for the user
The user has the permission

YES: To delete the max-min-memory
NO: Do not delete the max-min-memory

Choice of measuring unit.

Applies to all further settings.

Display of the measuring unit.

The measuring unit is shown in the display.
YES: 1s after every 10s
NO: Not shown

Select the first switching point.



Select delay time of the first switching output.
Range: 0.00 ... 99.99s
Resolution: 0.01s

Select contact function of the first switching point.

ncLS: Normally closed contact
noPn: Normally open contact

Main Programming - Continued

	<p>Select the switching type of the first switching output. nPN: n-switching PnP: p-switching</p>
	<p>Select the switching function of the first switching output. hYST: Hysteresis GATE: Gate Function</p>
	<p>Select the first reset point.</p>
	<p>Select delay time of the first switching output. Range: 0.00 ... 99.99s Resolution: 0.01s</p>
	<p>Only for the version with two switching points! Select the second switching point.</p>
	<p>Select delay time of the second switching output. Range: 0.00 ... 99.99s Resolution: 0.01s</p>
	<p>Only for the version with two switching points! Select the contact function of the second switching output. nCLs: Normally closed contact noPn: Normally open contact</p>
	<p>Only for the version with two switching points! Select the switching type of the second switching output. nPN: n-switching PnP: p-switching</p>
	<p>Only for the version with two switching points! Select the switching function of the second switching output. hYST: Hysteresis GATE: Gate function</p>
	<p>Only for the version with two switching points! Select the second reset point.</p>
	<p>Select the delay time of the second reset point. Range: 0.00 ... 99.99s Resolution: 0.01s</p>

Main Programming - Continued

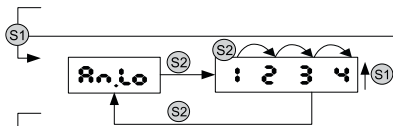

Only for the version with analog output!

Select the pressure value of the analog output at 4mA/0V.

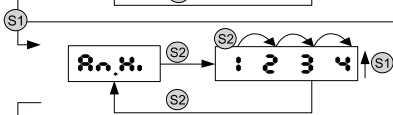

Only for the version with analog output!

Select the pressure value of the analog output at 20mA/10V.

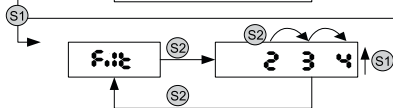

Select output filters

Range:	0.00...2.00s	
Resolution:	0.01s	
Grading:	Step Size	Range
	10ms	0.00...0.2s
	50ms	0.2...1.0s
	100ms	>1.0s

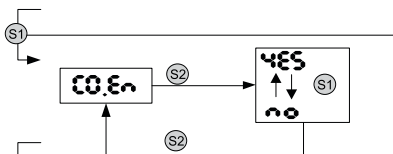

Authorization for the user.

The user has the permission

YES: To program

NO: To not program

the switching output in the user menu

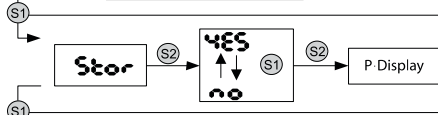

Save the previous changes.

YES: Save

NO: Not Save

returns to the actual pressure indication afterwards.

→ Return to the beginning of the set up menu by pressing the button **S1**.

To exit the menus

1. After the selection, the menu will automatically be closed whether the modified value is stored or not.
2. It is possible to exit the menu anytime by pressing the buttons **S1** and **S2** simultaneously.
3. If no button is pressed for 30 seconds, the menu will be closed automatically.

Error message

1. Flashing display of the actual pressure: measured pressure outside of range.
2. Flashing of the display during the programming: An invalid value was entered.
Examples: Switching point above/below the adjustment range, reset point above/below the adjustment range, analog output span is smaller than 20% of the adjustment range filter more than 2s. When this happens, the buttons are locked for 3s and the switch takes over the next possible value.

Technical Data

Configuration	Pressure, positive or negative
Pressure connection	¼" NPT
Setting	Menu-guided programming using control buttons Adjustable switching points, switchback points, switching function Programmable pressure units: bar, psi
Materials	
• Measuring component	Stainless steel, ceramic with NBR seal at less than 1500 psi (standard)
• Pressure connection	Stainless steel
• Housing	Stainless steel, plastic display electronics
Load change	> 10 million pressure cycles
Power Requirement	12... 30 VDC
Power consumption	≤ 50 mA, without load current
Outputs	2 switch outputs, programmable
	1 programmable switch output and 1 analog output, fixed like adjusting range
Switch outputs	
• Quantity	1 or 2 to N or P potential
• Function	Normally open contact (NO) or normally closed contact (NC), programmable
• Switching current	0.5 A
• Setting	Via display with control buttons
- Switching point	1 to 100% of full scale

- Hysteresis	1 to 100% of full scale
• Status indication	LED
Analog output	
• Signal	4 to 20 mA, 2-wire; 0 to 10 Vdc, 3-wire
• Load resistance	Current output: < 500 Ω , Voltage output: > 10 k Ω
• Hysteresis	0.3% of full scale for ceramic cell, 0.2% of full scale for thin film cell
Display	
• Type	7-segment LED, red, 4 digits, character height 7.6 mm
• Digits	-999 ... 9999
• Accuracy	1% of full scale
Repeatability	0.5% of full scale (BFSL)
Temperature ranges	
• Storage	-22...+176°F
• Media	-4...+176°F
• Ambient	-4...+176°F
• Thermal Effect	0.017 % of Full Scale/°F
Electrical connection	Round connector M 12x1; 4-pin
Protection class	IP 65
CE - symbol	Interference emission and interference immunity in accordance with EN 61 326
Electrical protection classes	Pole reversal and overvoltage protection
Weight	0.66 lbs

DIMENSIONS

Inches (mm)

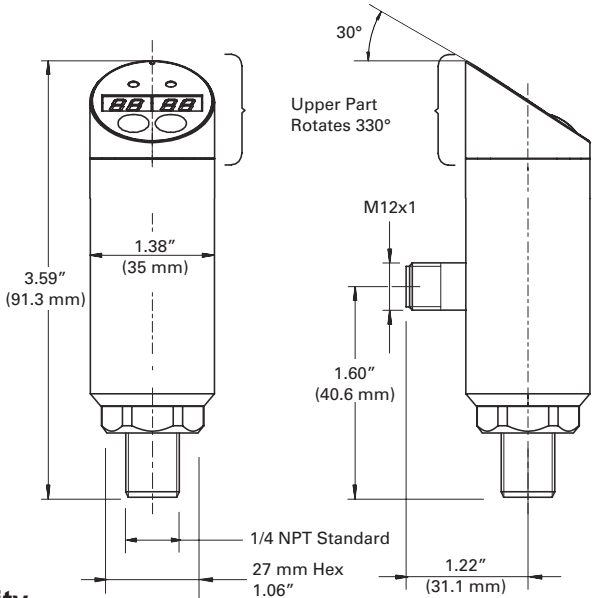

CE – Conformity

The switch complies with all requirements of EN 61 326 with regard to interference emission and immunity for use in industrial areas. We recommend the use of shielded cables. Installation and cable routing must be carried out correctly in order to maintain the effective protection from electromagnetic interference.

Maintenance

The pressure switches that are described in this document are maintenance free. The equipment will also operate in a stable state for long periods, meaning that regular adjustment or the like is not required.

Remove the device as soon as device malfunctions start to occur. The internals cannot be maintained by the customer. Replace the device or return it to the manufacturer to have it tested.

Troubleshooting

No modifications must be made to the equipment. Only the manufacturer is allowed to repair the device.

Cleaning

The exterior of the 800 series pressure switch can be cleaned using a soft, moistened cloth. Heavy soiling can be removed using a mild cleaning agent.

The switch must not be opened under any circumstances!

Aggressive chemicals or hard scrubbing can damage the surface, particularly the display film.

Disposal

The packaging and used parts must be disposed of in accordance with the regulations of the country in which the device is installed.

Notes:

*The
Instrumentation
Company*



CORPORATE HEADQUARTERS

1010 West Bagley Road • Berea, Ohio 44017

440.243.0888 • FAX 440.243.3472

E-MAIL: noshok@noshok.com

WEB: www.noshok.com

ISO 9001:2008
REGISTERED

NEPS08-1