

# A01 SERIES

## INDUSTRIAL CONTROLS

### Accessories

**FLUSH MOUNTING BEZELS** Dark grey plastic material – supplied with sealing washer

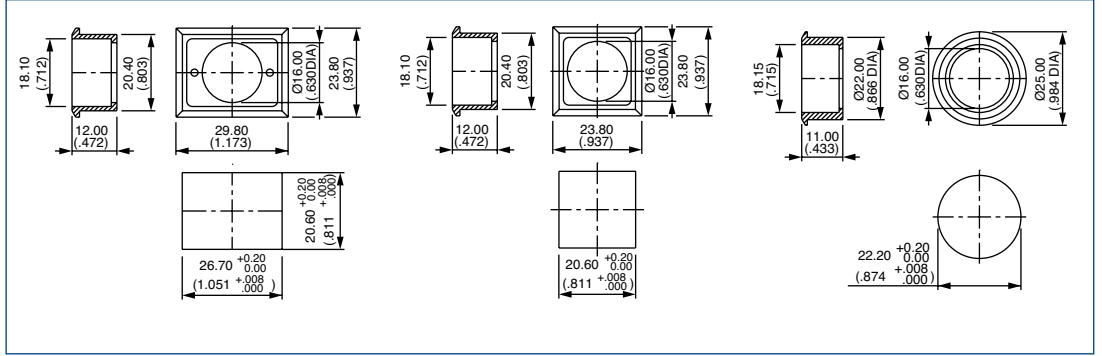

Rectangular **A01FM1**

Square **A01FM**

Round **A01FM2\***

**FLUSH MOUNTING BEZELS** Anodised aluminium/matt black

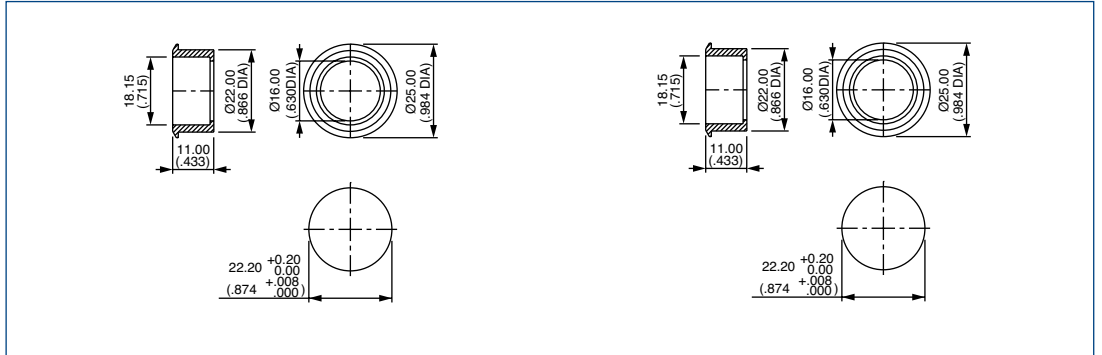

Round **A01FMM**

Round **A01FMMG**

**PCB SOCKET**

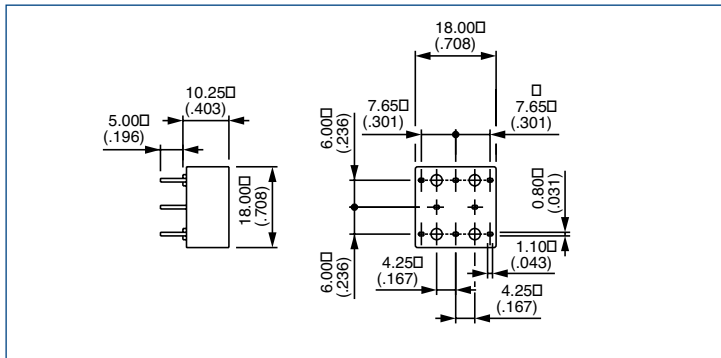

No of poles	Part No
Single pole, non illuminated	A01PC1
Double pole, non illuminated	A01PC2
Single pole, illuminated	A01PC3
Double pole, illuminated	A01PC4
Indicator	A01PC5
Single pole, E-stop	A01PC6
Double pole, E-stop	A01PC7

**FLAPGUARDS**

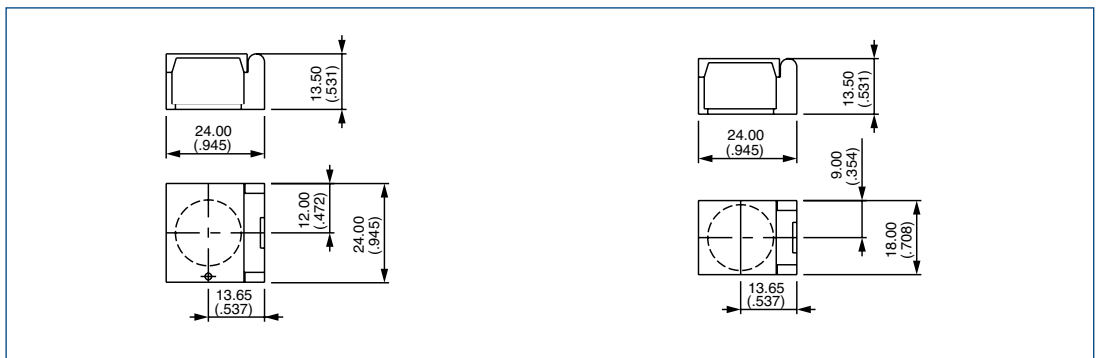

Rectangular **A01FG1**

Square/round **A01FG2**

# A01 SERIES

## Accessories

### METAL GUARDS

→ Slot as alternative to Ø2mm hole. Material : 1 mm thick aluminium.

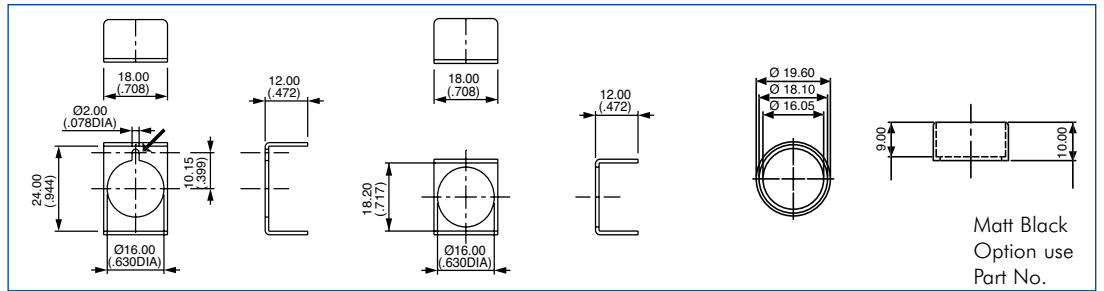

Rectangular **A01MG1**

Square **A01MG**

Round **A01MG2**

Matt Black  
Option use  
Part No.

**A01MG2G**

### ANTI ROTATION RING

Recommended to prevent product rotation

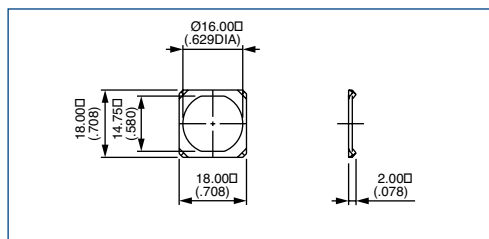

**A01LW**

### SWITCHBLOCK TERMINAL GUARDS

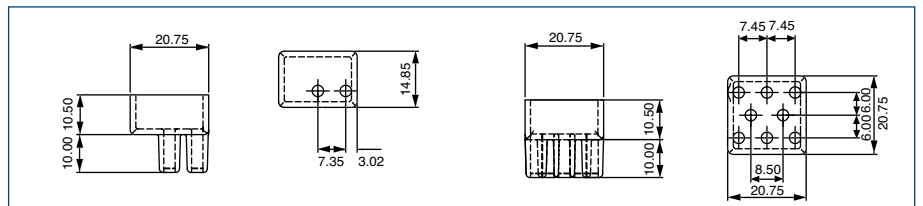

2 way **A01RTC2**

8 way **A01RTC8**

### BLANKING PLUGS

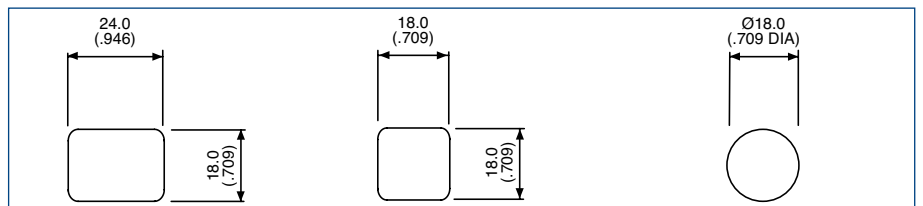

Rectangular **A0131**

Square **A0132**

Round **A0133**

### RESISTOR ASSEMBLY

Resistor assembly – 2 stage illumination



**A0152B + RISSP**



(DIM) normally closed

(BRIGHT) normally open

# A01 SERIES

## INDUSTRIAL CONTROLS

### Installation – tools

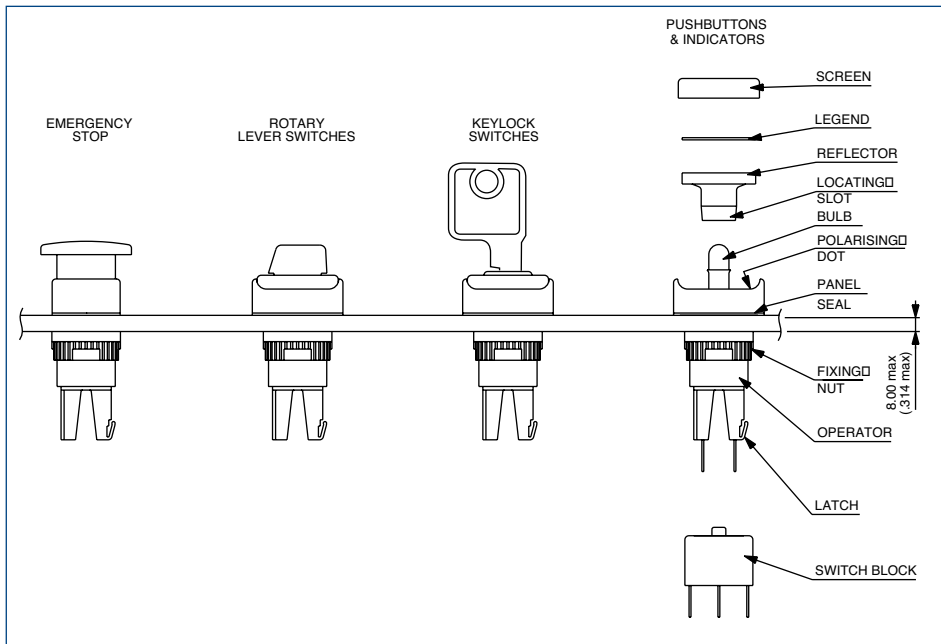

#### PANEL CUT-OUT

Round & square operators only

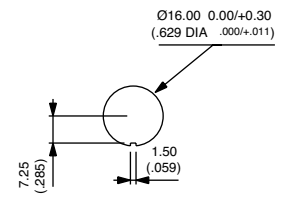

#### Rectangular operators only

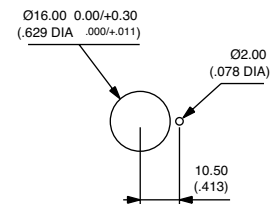

Max. panel thickness : 8mm (.314)

#### PANEL MOUNTING ASSEMBLY

- Drill/punch hole shaped as above.
- Assemble front operator through hole, fit fixing nut and tighten to a maximum torque of 0.8Nm using tool No. 30-0001.
- Wire chosen switch block as required and slide onto operator until latch engages.
- Fit bulb if required using tool No. 30-0002.
- Snap screen onto reflector assembly with legend in between if required and snap onto front operator TAKING CARE TO LINE UP THE LOCATING SLOT WITH THE POLARISING DOT, and not to damage the seal.

#### TO REMOVE BULB

Remove reflector/screen assembly. Use the bulb extractor 30-0002 to remove the bulb.

#### SWITCH BLOCK

To assemble switch block to front operator, firstly, TAKE CARE TO LINE UP SWITCH BLOCK WITH FRONT OPERATOR. Once in position slide on to front operator. N.B. Ensure latch is fully engaged correctly onto the switch block.

To remove switch block, depress the latch and slide the switch block off the operator.

#### FIXING NUT KEY



#### BULB REMOVER

