

32.768kHz SMD LOW PROFILE CRYSTAL

ABS13

ABS13

RoHS/RoHS II compliant.
Pb in high temperature solder

6.9 x 1.4 x 1.3 mm

Moisture Sensitivity Level: Level 1

(exempt 7(a) per RoHS II 2011/65/EU Annex)

FEATURES:

- Low frequency
- Plastic package with embedded heat resistant crystal in cylinder package
- Extended temperature -40°C to +85°C for industrial applications
- Suitable to RoHS compliant reflow

APPLICATIONS:

- Commercial & Industrial applications
- Wireless communications
- PDA and Palm Pilots

STANDARD SPECIFICATIONS:

Parameters	Minimum	Typical	Maximum	Units	Notes
Nominal Frequency	-----	32.768	-----	kHz	
Operating Temperature	-40	-----	+85	°C	
Turnover Temperature	+20	+25	+30	°C	
Storage Temperature	-55	-----	+125	°C	
Frequency Tolerance @+25°C	-20	-----	+20	ppm	See options
Frequency Coefficient (β)	-0.040	-0.034	-0.028	ppm/T ²	
Equivalent series resistance (R1)	-----	-----	65	kΩ	
Load capacitance (CL)	-----	12.5	-----	pF	See options
Drive Level	-----	-----	1	μW	
Aging	-3	-----	+3	ppm	@25°C±3°C First year
Insulation Resistance	500	-----	-----	MΩ	@ 100Vdc ± 15V

OPTIONS AND PART IDENTIFICATION:

(Left blank if standard)

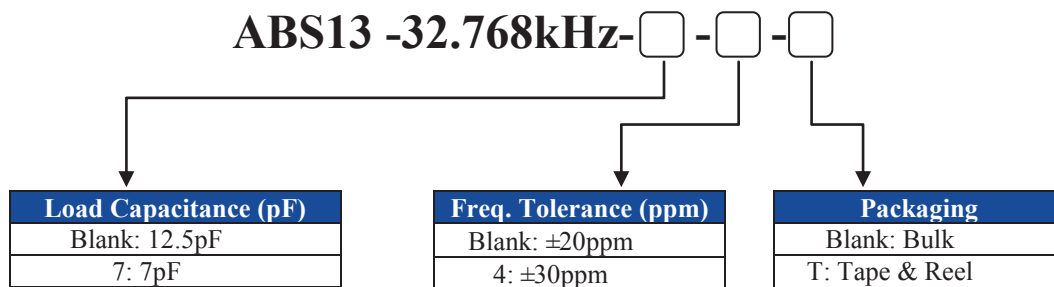

32.768kHz SMD LOW PROFILE CRYSTAL

ABS13

ABS13

RoHS/RoHS II compliant.
Pb in high temperature solder
(exempt 7(a) per RoHS II 2011/65/EU Annex)

6.9 x 1.4 x 1.3 mm

OUTLINE DRAWING:

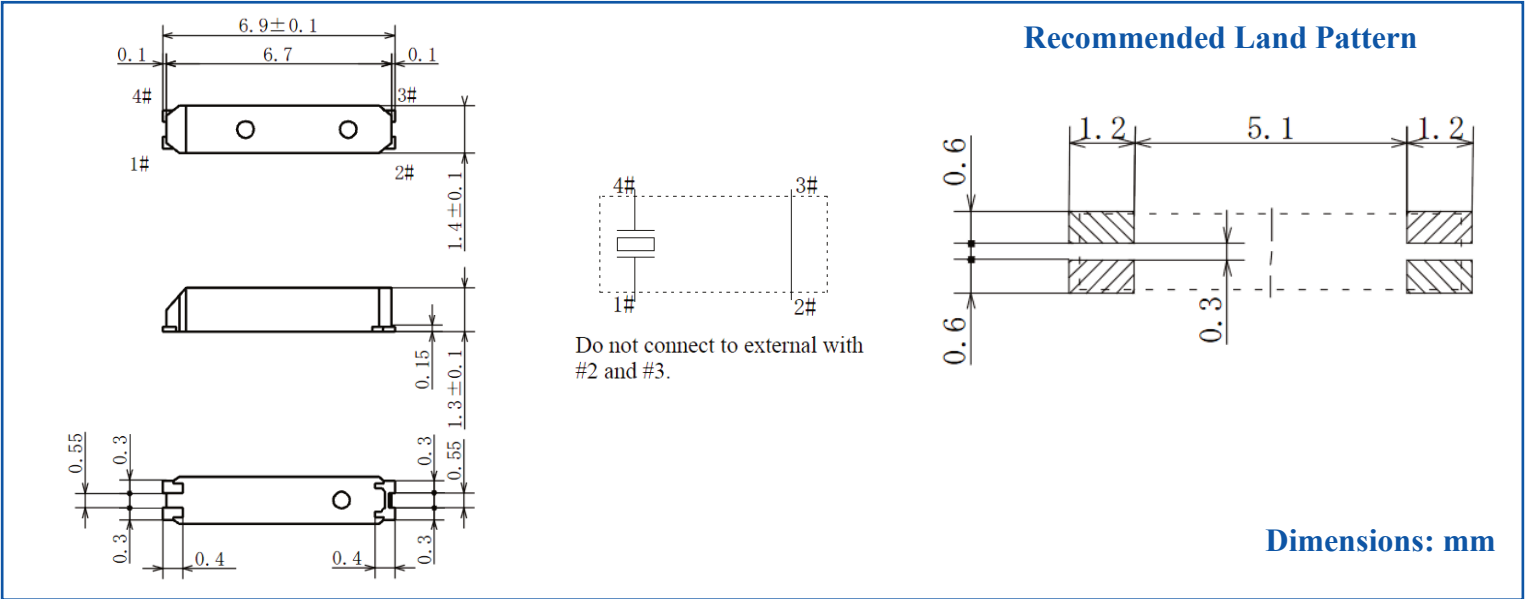

TAPE & REEL: T = Tape and reel 3,000pcs/reel

REFLOW PROFILE

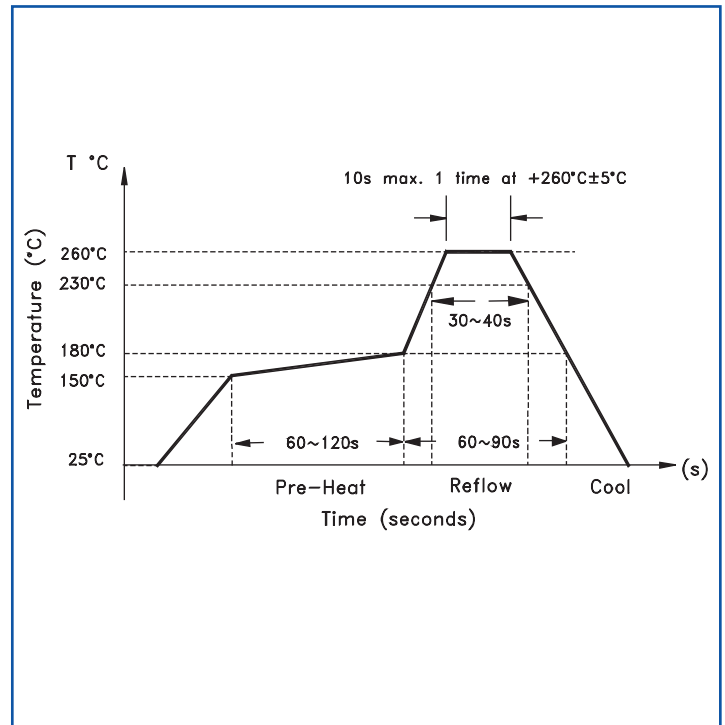
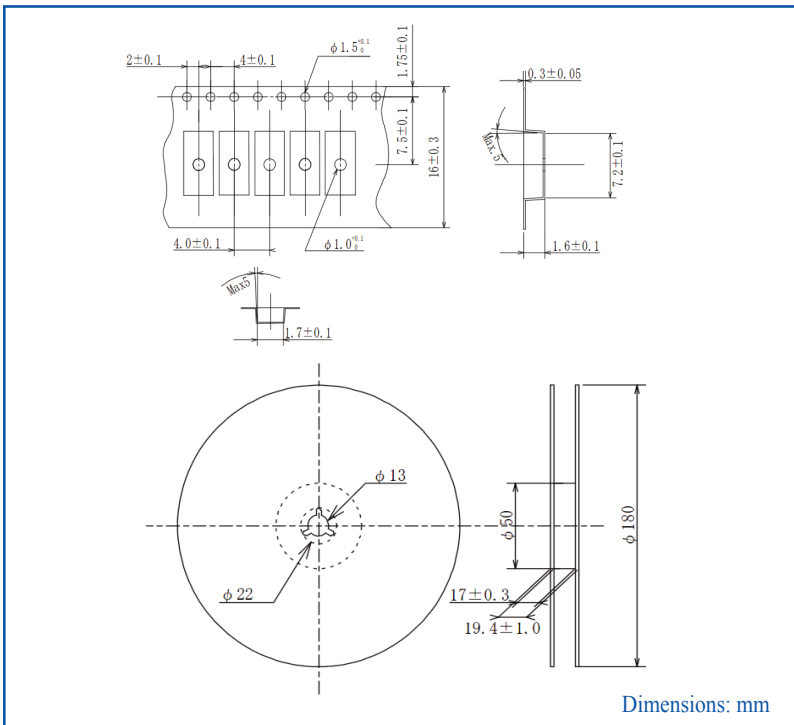

ATTENTION: Abracon Corporation's products are COTS – Commercial-Off-The-Shelf products; suitable for Commercial, Industrial and, where designated, Automotive Applications. Abracon's products are not specifically designed for Military, Aviation, Aerospace, Life-dependant Medical applications or any application requiring high reliability where component failure could result in loss of life and/or property. For applications requiring high reliability and/or presenting an extreme operating environment, written consent and authorization from Abracon Corporation is required. Please contact Abracon Corporation for more information.

ABRACON IS
ISO9001:2008
CERTIFIED



Visit www.abracon.com for Terms & Conditions of Sale **Revised: 12.18.12**
30332 Esperanza, Rancho Santa Margarita, California 92688
tel 949-546-8000 | fax 949-546-8001 | www.abracon.com