

LUXEON S1000

Optimized solution for applications requiring high flux and tight beam control

Technical Datasheet DS80

LUXEON
NEVER BEFORE POSSIBLE



LUXEON S1000

High Flux Density Product

Introduction

The LUXEON® S1000 emitters deliver uniform beam intensity and high flux density from a uniform source. This enables tight beam control at the system level using secondary optics to provide the high center beam intensity, uniform beam and crisp, single shadow required for high performance accent spotlighting applications. LUXEON S1000 delivers tight Correlated Color Temperature control to ensure consistency in system color point. In addition these parts deliver the efficacy, lifetime and reliability that all LUXEON LEDs are renowned for. This document contains the performance data needed to design and engineer LUXEON S1000 based applications. LUXEON S1000 features:

- Specified, targeted and tested hot, at real world operating temperatures: $T_j = 85^{\circ}\text{C}$, to ensure *in application* performance
- High flux density from 8mm diameter source products in 2700K, 3000K, 3500K, 4000K with 80 CRI and 3000K with 90 CRI
- Uniform intensity and color across source with high efficacy for sustainable design
- *Freedom from Binning* delivers color consistency within a single 3-step MacAdam ellipse
- Exceed ENERGY STAR® lumen maintenance requirements
- Recognized under the Component Recognition Program of Underwriters Laboratories Inc. UL listing E327436.

PHILIPS
LUMILEDS

Table of Contents

Product Nomenclature.....	3
Average Lumen Maintenance Characteristics	3
Environmental Compliance.....	3
Product Selection Guide for LUXEON S1000.....	4
Optical Characteristics for LUXEON S1000	5
Electrical Characteristics for LUXEON S1000.....	5
Absolute Maximum Ratings	6
Mechanical Dimensions	7
Relative Spectral Distribution vs.Wavelength Characteristics	8
Light Output Characteristics.....	9
Typical Forward Current Characterisics	10
Typical Radiation Pattern.....	11
Packaging.....	12
Product Binning and Labeling	13
LUXEON S1000 Color Bin Structure.....	14
Forward Voltage Bins.....	15

Product Nomenclature

LUXEON S1000 is tested and binned hot at $T_j = 85^\circ\text{C}$ and 700 mA DC.

The part number designation is explained as follows:

L X S A – B C D E

Where:

A — designates minimum CRI (value 8 for 80, 9 for 90)

B — designates radiation pattern (value P for Lambertian)

C — designates color (W for White)

D — designates nominal CCT (27 for 2700K, 30 for 3000K, 35 for 3500K and 40 for 4000K)

Therefore 3000K, 80 CRI product will be:

L X S 8 - P W 3 0

Average Lumen Maintenance Characteristics

Lumen maintenance for solid-state lighting devices (LEDs) is typically defined in terms of the percentage of initial light output remaining after a specified period of time. Philips Lumileds projects that LUXEON S1000 products will deliver, on average, 70% lumen maintenance (L70) at 50,000 hours of operation at a forward current of up to 700 mA. This projection is based on constant current operation with junction temperature maintained at or below 110°C . This performance is based on independent test data, Philips Lumileds historical data from tests run on similar material systems, and internal LUXEON reliability testing. Observation of design limits included in this data sheet is required in order to achieve this projected lumen maintenance.

Environmental Compliance

Philips Lumileds is committed to providing environmentally friendly products to the solid-state lighting market. LUXEON S1000 is compliant to the European Union directives on the restriction of hazardous substances in electronic equipment, namely the RoHS and REACH directives. Philips Lumileds will not intentionally add the following restricted material to the LUXEON S1000: lead, mercury, cadmium, hexavalent chromium, polybrominated biphenyls (PBB) or polybrominated diphenyl ethers (PBDE).

Product Selection Guide for LUXEON S1000

Junction Temperature = 85°C; Test Current = 700 mA

Table 1.

Nominal CCT	Part Number	Minimum CRI ^[1]	Typical R9	Minimum Luminous Flux (lm) Φ_v ^[1]	Typical Luminous Flux (lm) Φ_v ^[1]
2700K	LXS8-PW27	80	>20	1150	1250
3000K	LXS8-PW30	80	>20	1250	1390
3000K	LXS9-PW30	90	>50	1050	1175
3500K	LXS8-PW35	80	>20	1300	1420
4000K	LXS8-PW40	80	>20	1360	1450

Notes for Table 1:

1. Philips Lumileds maintains a tolerance of $\pm 6.5\%$ on luminous flux and ± 2 on CRI measurements.

Optical Characteristics for LUXEON S1000

Junction Temperature = 85°C; Test Current = 700 mA

Table 2.

Nominal CCT	Color Temperature CCT			Typical Total Included Angle ^[1] (degrees) $\theta_{0.90V}$	Typical Viewing Angle ^[2] (degrees) $2\theta_{1/2}$
	Min.	Typ.	Max.		
2700K	2656K	2725K	2795K	129	105
3000K	2963K	3045K	3129K	129	105
3500K	3359K	3465K	3575K	129	105
4000K	3849K	3985K	4129K	129	105

Notes for Table 2:

1. Total angle at which 90% of total luminous flux is captured.
2. Viewing angle is the off axis angle from lamp centerline where the luminous intensity is 1/2 of the peak value.

Electrical Characteristics for LUXEON S1000

Junction Temperature = 85°C; Test Current = 700 mA

Table 3.

Nominal CCT	Forward Voltage V_f ^[1] (V)			Typical Temperature Coefficient of Forward Voltage ^[2] (mV/°C) $\Delta V_f / \Delta T_j$	Typical Thermal Resistance Junction to Thermal Pad (°C/W) $R\theta_{j-c}$
	Min.	Typ.	Max.		
2700K, 3000K, 3500K, 4000K	23.5	25.6	29	- 15	1.3

Notes for Table 3:

1. Philips Lumileds maintains a tolerance of 0.5% on forward voltage measurements.
2. Measured at $25^\circ\text{C} \leq T_j \leq 125^\circ\text{C}$ at $I_f = 700$ mA.

Absolute Maximum Ratings

Table 4.

Parameter	Maximum Performance
DC Forward Current	900 mA
Peak Pulsed Forward Current	900 mA
ESD Sensitivity	< 8000V Human Body Model (HBM) Class 3A JESD22-A114-E < 400V Machine Model (MM) Class B JESD22-A115-B
Storage Temperature	- 40°C - 135°C
LED Junction Temperature ^[1]	115°C
Operating Case Temperature at 700 mA	- 40°C - 85°C
Autoclave Conditions	121°C at 2 ATM 100% Relative Humidity for 96 Hours Maximum
Reverse Voltage (V_r)	LUXEON S LEDs are not designed to be driven in reverse bias

Note for Table 4:

- I. Proper current derating must be observed to maintain junction temperature below the maximum

Mechanical Dimensions

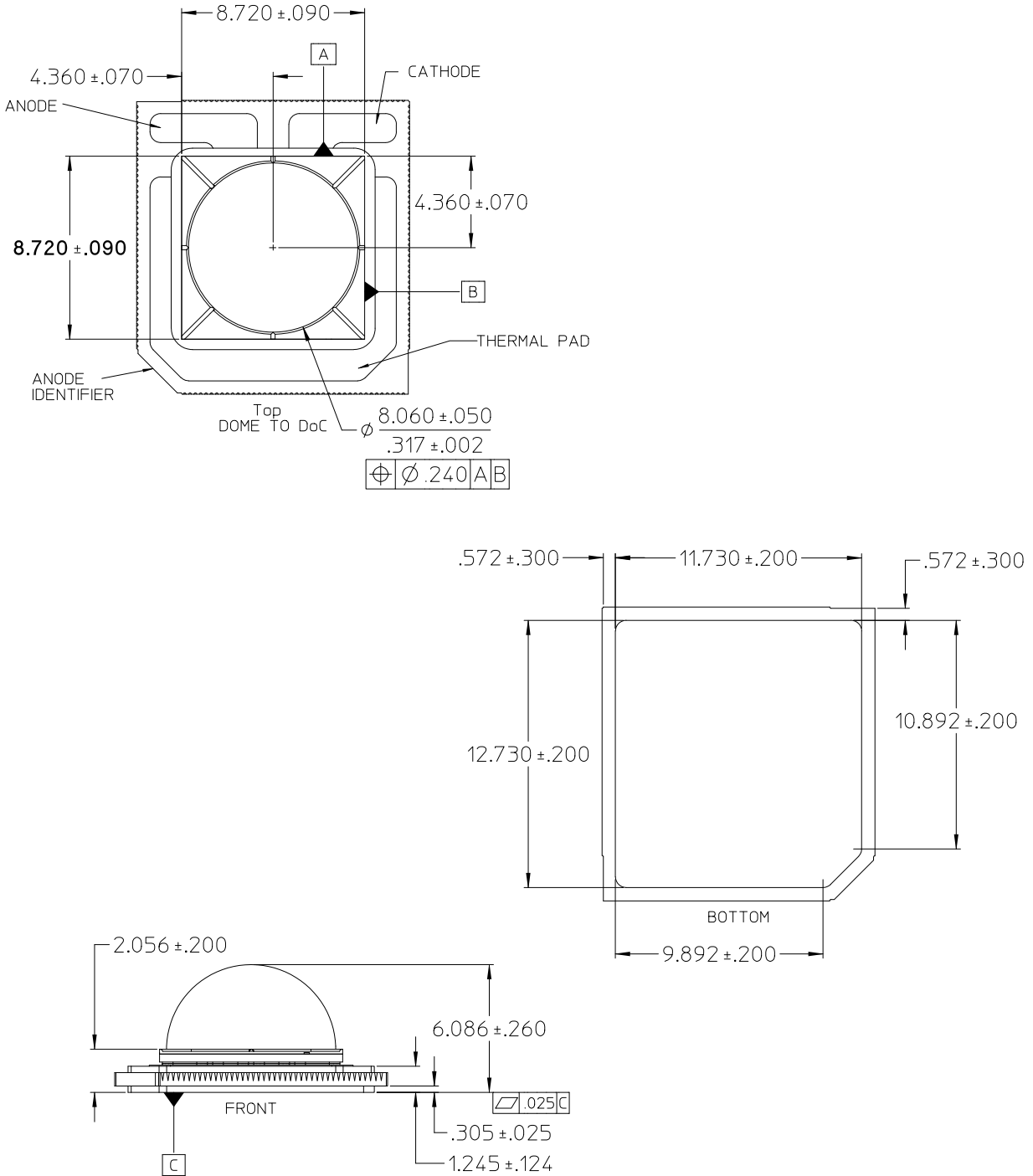

Figure 1. Package outline drawing.

Notes for Figure 1:

- Do not handle device by the lens. Excessive force on the lens may damage the lens itself or the interior of the device.
- Drawings not to scale..
- All dimensions are in millimeters.
- The Thermal Pad is electrically isolated from the Anode and Cathode contact pads.

Relative Spectral Distribution vs. Wavelength Characteristics

Relative Spectra at Test Current, Junction Temperature = 85°C

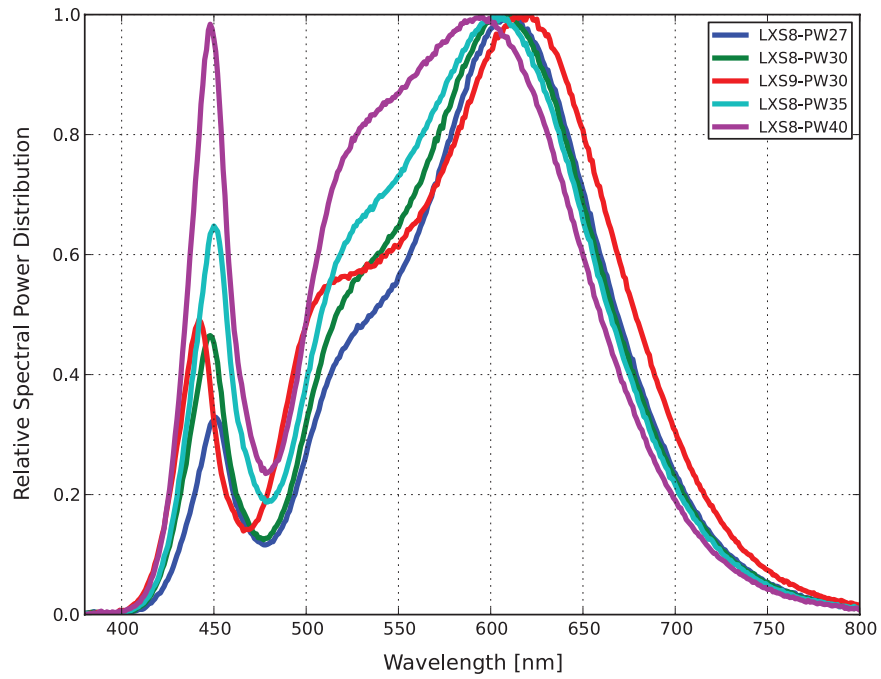

Figure 2. Color Spectra of LXSx-PWxx.

Light Output Characteristics

Relative Light Output vs. Junction Temperature

Test Current = 700 mA

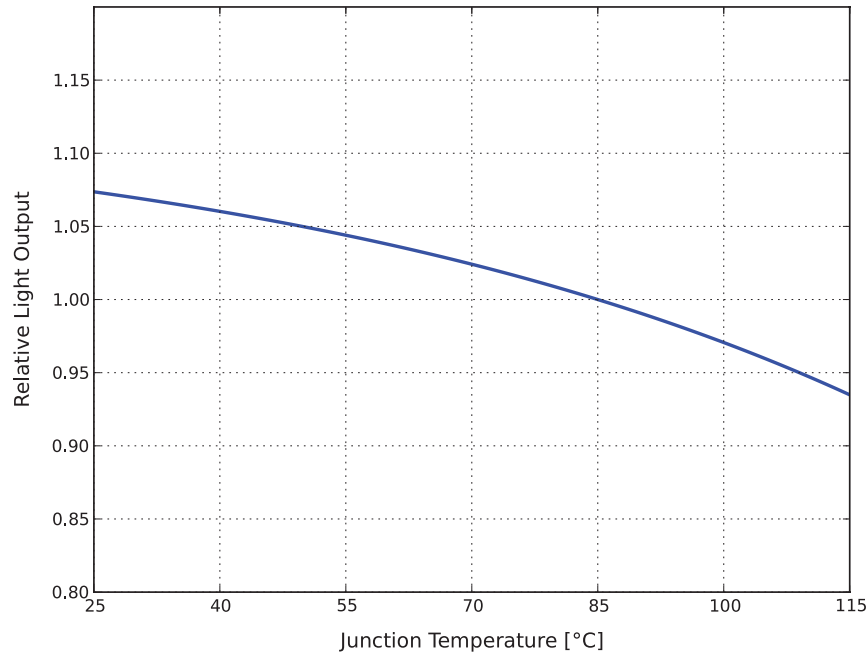

Figure 3. Relative light output vs. junction temperature, LXSx-PWxx.

Relative Light Output vs. Forward Current

Junction Temperature = 85°C

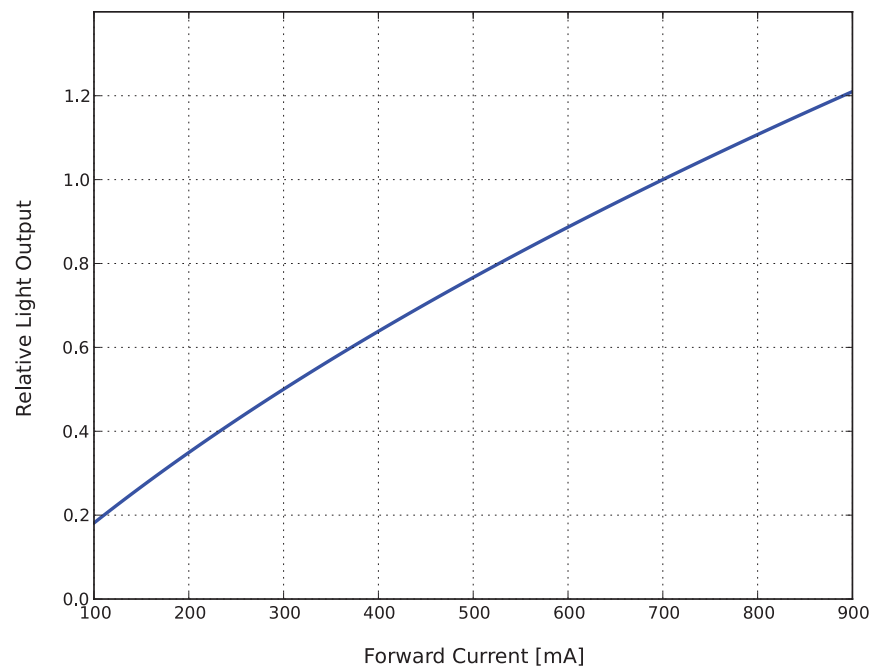

Figure 4. Typical relative light output vs. forward current, LXSx-PWxx.

Typical Forward Current Characteristics

Junction Temperature = 85°C

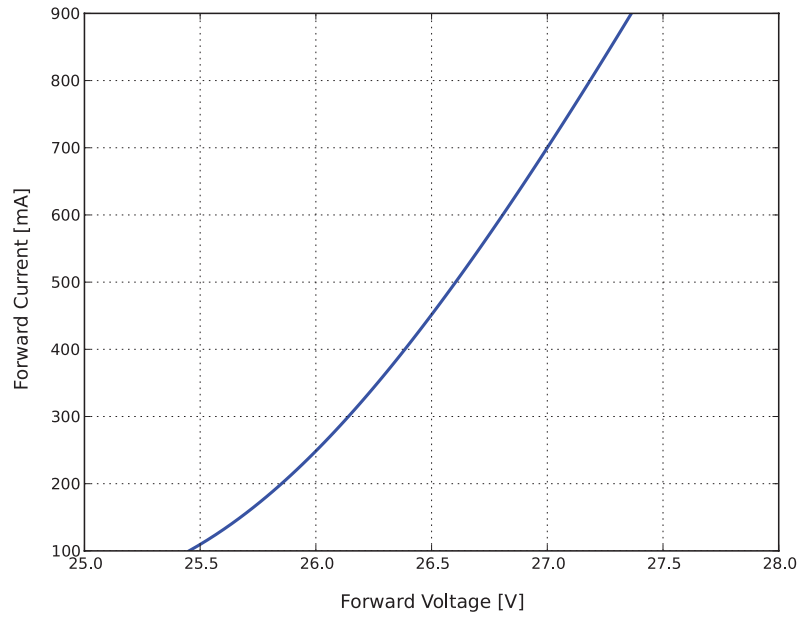

Figure 5. Typical forward current vs. forward voltage, LXSx-PWxx.

Typical Radiation Pattern

Typical Spatial Radiation Pattern

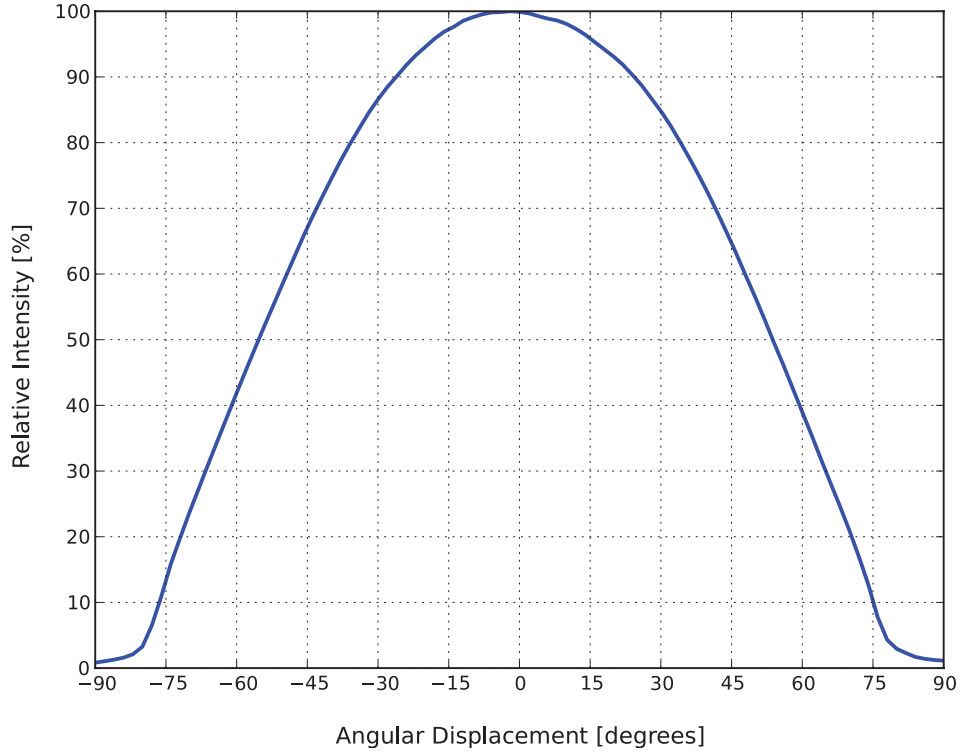

Figure 6. Typical representative spatial radiation pattern for LXSx-PWxx.

Typical Polar Radiation Pattern

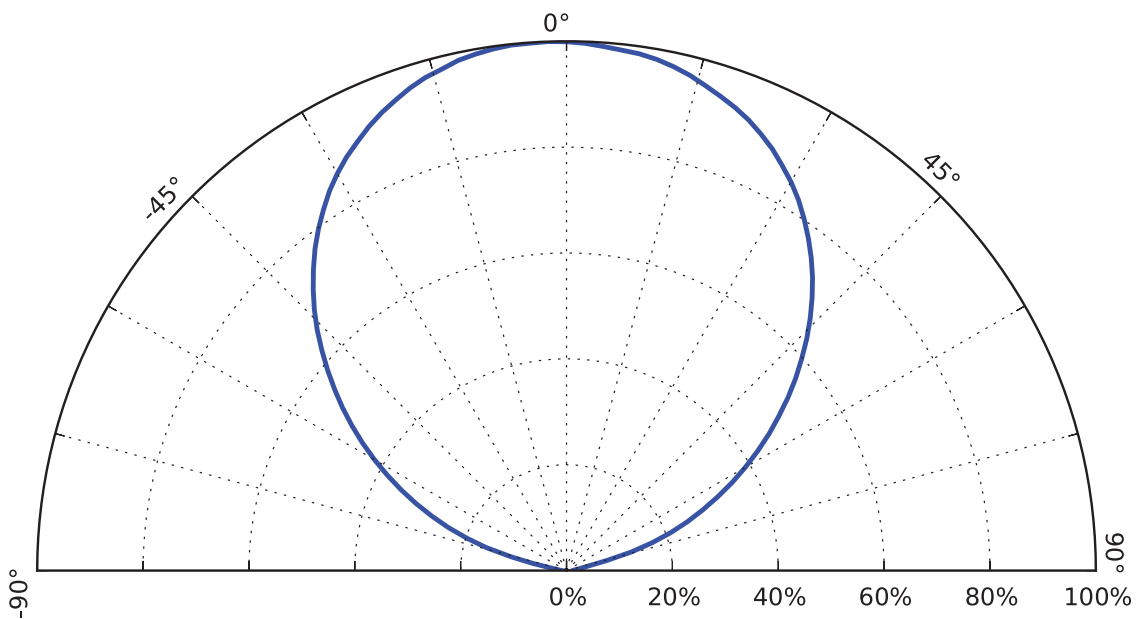

Figure 7. Typical representative polar radiation pattern for LXSx-PWxx.

Packaging

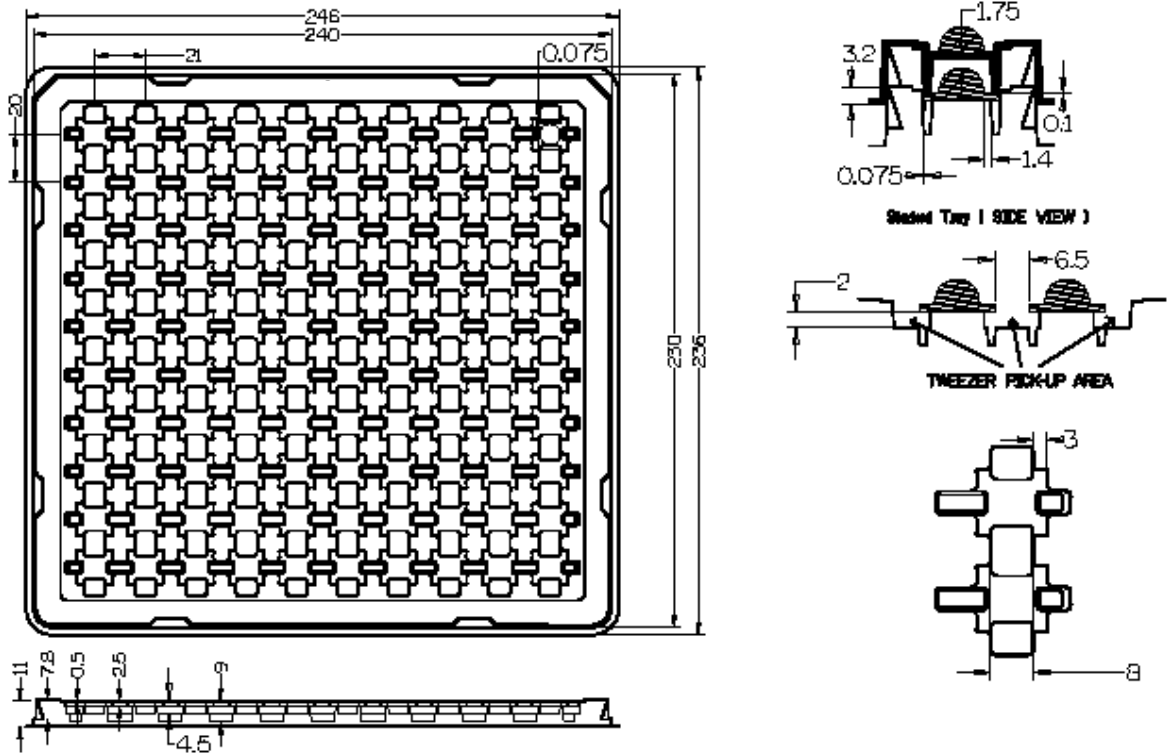

Figure 8. LUXEON S1000 devices are packaged in stackable trays containing 100 pieces per tray. The trays are designed to provide easy access to the thermal pad at the bottom of the LUXEON S1000 emitter.

Product Binning and Labeling

Purpose of Product Binning

In the manufacturing of semiconductor products, there is a variation of performance around the average values given in the technical data sheets. For this reason, Philips Lumileds bins the LED components for luminous flux, color and forward voltage (V_f).

Decoding Product Bin Labeling

LUXEON S1000 emitters are labeled using a four digit alphanumeric code (CAT code) depicting the bin values for emitters packaged in a single tray. All emitters packaged within a tray are of the same 3-variable combination.

Trays of LUXEON S1000 emitters are labeled with a four digit alphanumeric CAT code following the format below.

Ax3B

A = Flux bin (A,B,C etc.)

x3 = within 3 step MacAdam ellipse (x=8 for 2700K, x=7 for 3000K, x=6 for 3500K and x=5 for 4000K)

B = Vf bin (G,H,J etc.)

Luminous Flux Bins

Table 5 lists the standard photometric luminous flux bins for LUXEON S1000 emitters (tested and binned at 700 mA with junction temperature of 85°C).

Although several bins are outlined, product availability in a particular bin varies by production run and by product performance.

Table 5. Flux Bins

Bin Code	Minimum Photometric Flux (lm)	Maximum Photometric Flux (lm)
A	1050	1100
B	1100	1150
C	1150	1200
L	1200	1250
M	1250	1300
N	1300	1360
P	1360	1420
Q	1420	1480
R	1480	1540
S	1540	1615
T	1615	1690
U	1690	1765
V	1765	1840

LUXEON S1000 Color Bin Structure

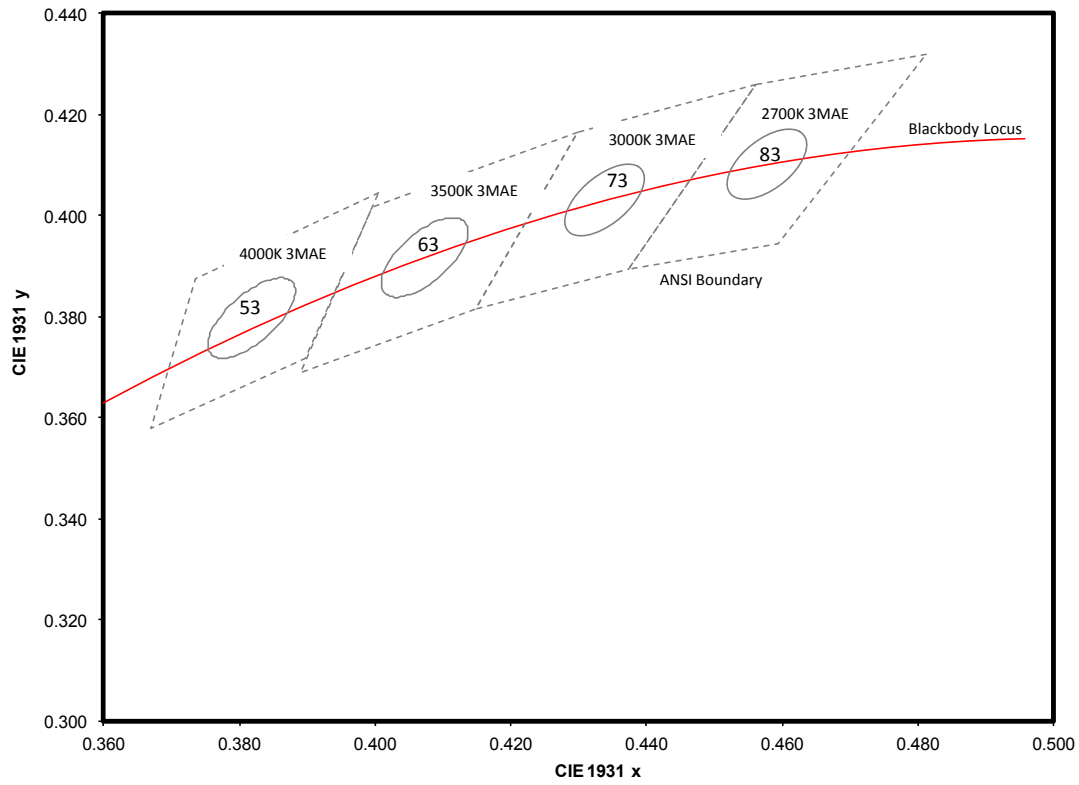

Figure 9. Color Binstructure of LXSx-PWxx.

Table 6. 3 MacAdam Ellipse

Based on: ANSI C78.376-2001 and ANSI C78.377-2008

ANSI Bins	x_{center}	y_{center}	Major axis, a	Minor axis, b	Elliptical angle
2700K	0.4578	0.4101	0.0081	0.0042	53.70°
3000K	0.4338	0.4030	0.00834	0.00408	53.22°
3500K	0.4073	0.3917	0.00927	0.00414	54.00°
4000K	0.3818	0.3797	0.00939	0.00402	53.72°

Forward Voltage Bins

Table 7 lists minimum and maximum V_f bin values per emitter. Although several bins are outlined, product availability in a particular bin varies by production run and by product performance.

Table 7. V_f Bins

Bin Code	Minimum Forward Voltage (V)	Maximum Forward Voltage (V)
G	23.5	24.5
H	24.5	26
J	26	27.5
K	27.5	29

Company Information

Philips Lumileds is a leading provider of LEDs for everyday lighting applications. The company's records for light output, efficacy and thermal management are direct results of the ongoing commitment to advancing solid-state lighting technology and enabling lighting solutions that are more environmentally friendly, help reduce CO₂ emissions and reduce the need for power plant expansion. Philips Lumileds LUXEON® LEDs are enabling never before possible applications in outdoor lighting, shop lighting, home lighting, consumer electronics, and automotive lighting.

Philips Lumileds is a fully integrated supplier, producing core LED material in all three base colors, (Red, Green, Blue) and white. Philips Lumileds has R&D centers in San Jose, California and in the Netherlands, and production capabilities in San Jose, Singapore and Penang, Malaysia. Founded in 1999, Philips Lumileds is the high flux LED technology leader and is dedicated to bridging the gap between solid-state technology and the lighting world. More information about the company's LUXEON LED products and solid-state lighting technologies can be found at www.philipslumileds.com.

©2012 Philips Lumileds Lighting Company. All rights reserved.
Product specifications are subject to change without notice.

PHILIPS
LUMILEDS

www.philipslumileds.com
www.philipslumileds.cn.com