

Part Number : **CM40**

Type	Size	Rating	Description
Incandescent	T10	6.3V 150mA	T-3¼ Miniature Edison Screw lamp

Dimensions(mm):

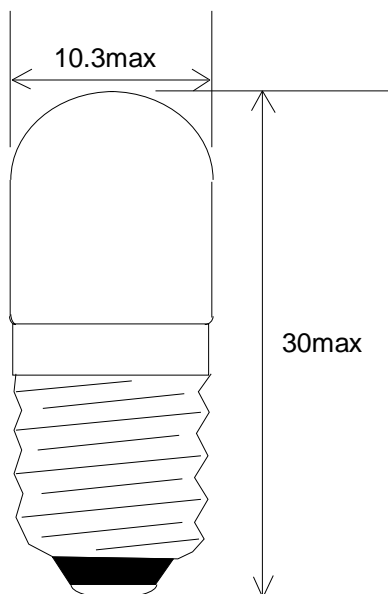

TEST VOLTS	CURRENT (mA)			LIGHT OUTPUT (Lm)			LIFE Hours
	Min.	Nom.	Max.	Min.	Nom.	Max.	
6.3	135	150	165	4.9	6.5	8.1	3,000

**Notes:**

- 1 Lamp base E10/13 in accordance with IEC61-1, (BS EN 60061-1) sheet 7004-22-x.
- 2 Lamp marking **CML40 6.3V 150mA**
- 3 Filament shape C-2R
- 4 Bead colour: White or Clear
- 5 RoHS and REACH SVHC compliant

Issue # 1 : 6June13