

DESCO INDUSTRIES ESD AWARENESS BOOKLET



**PLEASE READ THOROUGHLY
BEFORE WORKING ON
OR HANDLING
ESD SUSCEPTIBLE
COMPONENTS OR ASSEMBLIES**

Use as part of Training Plan required by ANSI/ESD S20.20

ESD CONTROL PROGRAM PLAN

“The Organization shall prepare an ESD Control Program Plan that addresses each of the requirements of the Program. Those requirements include:

- Training
- Compliance Verification
- Grounding / Equipotential Bonding Systems
- Personnel Grounding
- EPA Requirements
- Packaging Systems
- Marking”

[ANSI/ESD S20.20-2007 section 7.1]

“The selection of specific ESD control procedures or materials is at the option of the ESD Control Program Plan preparer and should be based on risk assessment and the established electrostatic discharge sensitivities of parts, assemblies, and equipment.” [ANSI/ESD S20.20-2007 Annex B]

TRAINING PLAN

“Initial and recurrent ESD awareness and prevention training shall be provided to all personnel who handle or otherwise come into contact with any ESDS [ESD sensitive] items. Initial training shall be provided before personnel handle ESDS items. The type and frequency of ESD training for personnel shall be defined in the Training Plan. The Training Plan shall include a requirement for maintaining employee training records and shall document where the records are stored. Training methods and the use of specific techniques are at the Organization’s discretion. The training plan shall include the methods used by the Organization to verify trainee comprehension and training adequacy.” [ANSI/ESD S20.20-2007 section 7.2]

Desco Industries does not provide any express warranties and disclaims all statutory and implied warranties (including implied warranty of merchantability and fitness for a particular purpose) in the use of this booklet. In no event shall Desco Industries be liable for any damages with respect to its furnishing of this written document. ESD training should be repeated as specified in the company’s written ESD Control Plan. The quizzes included in this booklet may be determined as possible “objective evaluation technique to ensure trainee comprehension and training adequacy.” The written ESD Control Plan should be in accordance with ANSI/ESD S20.20-2007 (a copy can be downloaded at no charge from the ESD Association website *ESDA.org* which can be accessed via the Desco Industries website, *DescoIndustries.com*. Also, other documents such as the ESD Handbook ESD TR20.20 can be purchased).

“The 100 volt HBM limit was selected for ANSI/ESD S20.20 as the baseline susceptibility threshold since a large majority of the ESD susceptible products on the market have a sensitivity of greater than 100 volts.” [ESD Handbook ESD TR20.20-2008 section 1.1 Overview] For more sensitive items such as HBM (Human Body Model) Class 0, see page 15 for suggested practices.

“ANSI/ESD S20.20 is the culmination of the ESD Association’s response to the request of the US Department of Defense to write a commercial version of MIL-STD-1686, Electrostatic Discharge Control Program for Protection of Electrical and Electronic Parts, Assemblies and Equipment (Excluding Electrically Initiated Explosive Devices).” [ESD Handbook ESD TR20.20-2008 section 1.1 Overview]

ESD BASICS FOR ESD PROGRAMS PER ANSI/ESD S20.20

Electrostatic Discharge [ESD] can damage components and products containing electronics. It is the hidden enemy in many high-tech factories. Often this damage cannot be detected by quality control inspections, and can be very frustrating; adversely impacting productivity, quality, product reliability and thus a company's reputation and profitability.

The prerequisites of ESD control are:

- Identify ESD Protected Area [EPA]
- Identify ESD sensitive items [ESDS]
- Provide ESD control training

The ESD protected area should have signage, often including aisle tape, to clearly identify where it is. You need to understand and follow the basics of ESD control to limit the generation of ElectroStatic charges, limit and slow discharges in the EPA.

ESD BASICS

Protect your work following these guidelines:

- Only handle unpackaged ESD sensitive items [ESDS] in the ESD protected area [EPA] when grounded
- Only allow trained or escorted people in the EPA
- Ground all conductors including people in the EPA

- Use continuous monitors or test wrist straps at least daily
- If ESD footwear is used, test at least daily
- Visually check that grounding cords are connected
- Keep wristband snug, foot grounder grounding tab in shoe, and ESD smocks covering all clothing on torso
- Keep work area clean and clear of all non essential insulators, or neutralize essential insulators with ionizers with the airflow directed towards the work area
- Use packaging with shielding properties to store or transport ESDS outside the EPA

GROUNDING AND PERSONNEL SAFETY

This booklet will deal with ESD basics. ElectroStatic charges or static electricity can be everywhere, however conductors can be effectively grounded and charges removed to ground. A fundamental rule in ESD control is to ground all conductors, including people.

However, while ESD control is important, it is of secondary importance to employee safety. Personnel should not be grounded in situations where they could come into contact with voltage over 250 volts AC.

UL Caution, Underwriters Laboratories states regarding listed personnel grounding items:

"Note: This product is not recommended for use on equipment with operating voltage exceeding 250 VAC.

CAUTION: The ESD Series is for electrostatic control. It will not reduce or increase your risk of receiving electric shock when using or working on electrical equipment. Follow the same precautions you would use without [the personnel grounding item], including:

- *Make certain that equipment having a grounding type plug is properly grounded.*
- *Make certain that you are not in contact with grounded objects other than through the ESD Series."*

STATIC ELECTRICITY, ELCTROSTATIC CHARGE

All materials can tribocharge or generate ElectroStatic charges. This is static electricity which is an electrical charge at rest. When an electrical charge is not at rest, but discharges, problems can occur and we will discuss ESD [ElectroStatic Discharge] in some detail later.



Static electricity can be a very hair-raising event.

Remember that ElectroStatic charges and ElectroStatic discharges are different.

All matter is constructed from atoms which have negatively charged electrons circling the atom's nucleus which includes positively charged protons. The atom having an equal number of electrons and protons balances out having no charge.

ElectroStatic charges are most commonly created by contact and separation:

"For most people, static electricity is represented by the noise or crackle heard on a radio that interferes with good reception or the shock experienced when touching a metal object after walking across a carpeted room or sliding across a car seat. Static electricity is also observed as static cling when clothes are stuck together after coming out of a clothes dryer. Most of the time, people observe static electricity when the weather is cold and dry." "While many people tend to think of static electricity as being at rest or not moving, static electricity causes the most concern when it ceases to be stationary." [ESD Handbook ESD TR20.20 section 2.1 Basics of Static Electricity, Introduction]

"Electrostatic charge is most commonly formed by the contact and separation of two materials. The materials may be similar or dissimilar although dissimilar materials tend to liberate higher levels of static charge. An example is a person walking across the floor. Static electricity is produced when the person's shoe soles make contact, then separate from the floor surface. Another example is an electronic device sliding into or out of a bag, magazine or tube." [ESD Handbook ESD TR20.20-2008 section 2.3 Nature of Static Electricity]

- When two surfaces contact then separate
- Some atom electrons move from one surface to the other, causing imbalance

One surface has a positive charge and one surface has a negative charge.

CHARGE GENERATION OR TRIBOCHARGING EXAMPLES

The simple separation of two surfaces, as when tape is pulled off a roll, can cause the transfer of electrons between surfaces, generating an ElectroStatic charge.

- Unwinding a roll of tape

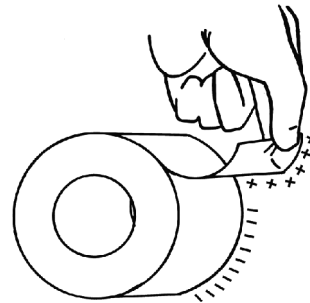

- Gas or liquid moving through a hose or pipe
- A person walking across a floor with heels and soles contacting and separating from the floor

The amount of static electricity generated varies, and is affected by materials, friction, area of contact, and the relative humidity of the

environment. At lower relative humidity, charge generation will increase as the environment is drier. Common plastics generally create the greatest static charges.

Typical Electrostatic Voltages

Many common activities may generate charges on a person's body that are potentially harmful to electronics components. (A higher charge is generated at low humidity, in a dry environment)

- Walking across carpet, 1,500 to 35,000 volts

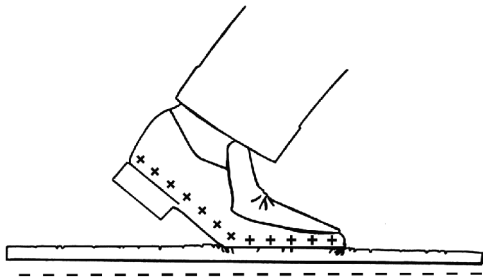

- Walking over untreated vinyl floor, 250 to 12,500 volts
- Vinyl envelope used for work instructions, 600 to 7,000 volts
- Worker at bench, 700 to 6,000 volts
- Picking up a common plastic bag from a bench, 1,200 to 20,000 volts

ELECTROSTATIC DISCHARGE (ESD)

If two items are at the same electrostatic charge or equipotential, no discharge will occur.

However if two items are at different levels of ElectroStatic charge, they will want to come into balance. If they are in close enough proximity, there can be a rapid, spontaneous transfer of electrostatic charge. This is called discharge or ElectroStatic Discharge (ESD).

Examples in daily life:

- Lightning, creating lots of heat and light



- The occasional zap felt when reaching for a door knob

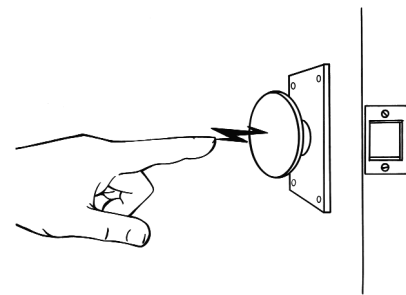

- The occasional zap felt when sliding out of an automobile and touching the door handle

"The phenomenon of forming an electrostatic charge by contact and separation of materials is known as "triboelectric charging", from the Greek "tribos" meaning "to rub", and "elektros" meaning "amber", as mentioned above. It involves the transfer of electrons between materials. The atoms of a material with no static charge will have an equal number of positive (+) protons in their nucleus and negative (-) electrons orbiting the nucleus ... and is electrically neutral. ...

When the two materials are placed in contact, negatively charged electrons will transfer from the surface of one material to the other material. Electrons are carried off upon separation of the two materials. The material that loses electrons becomes positively charged, while the material that gains electrons is negatively charged.

The amount of charge created by triboelectric charging is affected by the area of contact, the speed of separation, relative humidity, material work function, surface energy and other factors. Once the charge is formed on a material, it becomes an "electrostatic" charge (if it remains on the material). This charge may be transferred from the material, creating an ESD event."

[ESD Handbook ESD TR20.20 section 2.3 Nature of Static Electricity]

In a normal environment like your home, there are innumerable ESD events occurring, most of which you do not see or feel. It takes a discharge of about 2,000 volts for a person to feel the "zap". It requires a much larger ESD event to arc and be seen. While a discharge may be a nuisance in the home, ESD is the hidden enemy in a high tech manufacturing environment. Modern electronic circuitry can be literally burned or melted from these miniature lightning bolts. ESD control is necessary to reduce and limit these ESD events.



Direct catastrophic failures, meaning completely failed or dead components.

A latent defect can occur when an ESD sensitive item is exposed to an ESD event and is partially degraded. It may continue to perform its intended function, so may not be detected by normal inspection. However, intermittent or permanent failures may occur at a later time.

TYPES OF ESD DEVICE DAMAGE

ESD damage to electronic components can be:

- Catastrophic Failures
- Latent Defects

EVEN LESS THAN 100 VOLTS MIGHT DAMAGE A COMPONENT



Latent defects, meaning degraded or wounded components.

Catastrophic failure causes a failure in an ESD sensitive item that is permanent. The ESD event may have caused a metal melt, junction breakdown or oxide failure. Normal inspection is able to detect a catastrophic failure.

COSTLY EFFECTS OF ESD

A catastrophic failure of an electronic component can be the least costly type of ESD damage as it may be detected and repaired at an early manufacturing stage.

Per ESD Handbook ESD TR20.20-2008 section 2.7 Device Damage - Types and Causes "Electrostatic damage to electronic devices can occur at any point, from the manufacture of the device to field service of systems. Damage results from handling the devices in uncontrolled surroundings or when poor ESD control practices are used. Generally damage can manifest itself as a catastrophic failure, parametric change or undetected parametric change (latent defect)."

2.7.1 Catastrophic Failures "When an electronic device is exposed to an ESD event it may no longer function. The ESD event may have caused a metal melt, junction breakdown, or oxide failure. The device's circuitry is permanently damaged, resulting in a catastrophic failure."

2.7.2 Latent Defects "A device that is exposed to an ESD event may be partially degraded, yet continue to perform its intended function. However, the operating life of the device may be reduced dramatically. A product or system incorporating devices with latent defects may experience a premature failure after the user places them in service. Such failures are usually costly to repair and in some applications may create personnel hazards." It is easy with the proper equipment to confirm that a device has experienced catastrophic failure or that a part is degraded or fails test parameters. Basic performance tests will substantiate device damage. However, latent defects are virtually impossible to prove or detect using current technology, especially after the device is assembled into a finished product. Some studies claim that the number of devices shipped to users with latent defects exceeds the number that fail catastrophically due to ESD in manufacturing."

Latent damage caused by ESD is potentially more costly since damage occurs that cannot be felt, seen, or detected through normal inspection procedures. Latent defects can be very expensive as the product passes all inspection steps, and the product is completed and shipped. Latent defects can severely impact the reputation of a company's product. Intermittent failures after shipping a product can be frustrating, particularly when the customer returns a product, reporting a problem which the factory again fails to detect. It consequently passes inspection and the product is returned to the customer with the problem unresolved.

The worst event is when the product is installed in a customer's system, and performs for a while and then performs erratically. It can be very expensive to troubleshoot and provide repairs in this situation.

Catastrophic failures are detected during inspection but components with latent defects pass as good.

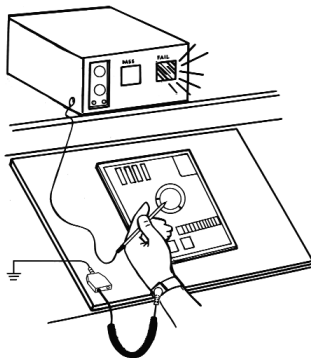

One study indicated the cost to be:

- \$10 Device
- \$10 Device in board - \$100
- \$10 Device in board and in system - \$1,000
- \$10 Device and system fails - \$10,000

Per ESD Handbook ESD TR20.20-2008 section 2.2 "Electronic items continued to become smaller, faster and their susceptibility to static damage increased...all electronic devices required some form of electrostatic control to assure continued operation and product reliability."

Per ESD Handbook ESD TR20.20-2008 section 5.3.2.1 "Static electricity is a natural phenomenon that occurs in all climates and at all levels of relative humidity year round. Most people cannot feel an electrostatic discharge unless the static voltage is greater than 2,000 volts. However, some electronic circuitry can be damaged by ESD that is less than 2,000 volts. The damage can be done without people having any sensation of the ESD event."

When a wrist strap is worn properly and connected to ground, the person wearing it will stay near ground potential."

Industry experts have estimated average electronics product losses due to static discharge to range from 8 to 33%. Others estimate the actual cost of ESD damage to the electronics industry as running into the billions of dollars annually.

ESD CONTROL

Many firms consider all electronic components ESD sensitive. It is critical to be aware of the most sensitive item being handled in your factory. As electronic technology advances, electronic circuitry gets progressively smaller. As the size of components is reduced, so is the microscopic spacing of insulators and circuits within them, increasing their sensitivity to ESD. As you can predict, the need for proper ESD protection increases every day.

Any ESD sensitive item should be identified with the ESD susceptibility symbol, either on itself or its container.



The ESD Susceptibility Symbol (also called Sensitivity or Warning Symbol) identifies items that can be damaged by ESD and should be unpackaged and handled while grounded at an ESD protected workstation.

Most firms use the ANSI/ESD S20.20 document to construct their ESD control plan which is based on handling ESD sensitive items having a Human Body Model withstand voltage of 100 volts or greater. The Human Body Model simulates discharges from a person and increasingly tests an electronic device at higher and higher discharges until it fails, thus establishing the device's withstand voltage.

OHM'S LAW

At this point we should consider some basic physics:

Ohm's law is an extremely useful equation in the field of electrical/electronic engineering because it describes how voltage, current and resistance are interrelated.

Ohm's law states that, in an electrical circuit, the current passing through a conductor between two points is directly proportional to the potential difference (i.e. voltage drop or voltage) across the two points, and inversely proportional to the resistance between them.

Resistance determines how much current will flow through a component. A very high resistance allows a small amount of current to flow. A very low resistance allows a large amount of current to flow. Resistance is measured in ohms.

Per ESD Handbook ESD TR20.20-2008 section 5.3.6.1.2 ESD Effects "In the electronics industry, smaller device geometries have resulted in higher density devices. ESD events can cause device damage such as metal vaporization, punch-through of thin oxide layers, or other failure modes. As mentioned earlier ESD events may or may not weaken devices so that they still pass production testing, but fail when installed in a customer's equipment."

Per ESD Handbook ESD TR20.20-2008 section 4.1.1 Determining Part ESD Sensitivity "The first step in developing an ESD Control Program plan is to determine the part, assembly or equipment sensitivity level under which the plan is to be developed. The organization can use one of several methods to determine the ESD sensitivity of the products that are to be handled. Some of the various methods are: 1) Assumption that all ESD products have a HBM sensitivity of 100 volts; 2) Actual testing of products using accepted test methods."

Resistance to ground (RTG) is a measurement that indicates the capability of an item to conduct an electrical charge (current flow) to an attached ground connection.

The measurement may be shown in various ways. Most commonly:

- 1 kilohm
- 1 kΩ
- 1 x 10³ ohm
- 1 x 10E3 ohm
- 10³ ohm

Prefix	Symbol	Scientific Notation	Common Usage
kilo-	K	1 x 10 ³ or 10E3	1,000 or one thousand
mega-	M	1 x 10 ⁶ or 10E6	1,000,000 or one million
giga-	G	1 x 10 ⁹ or 10E9	1,000,000,000 or one billion

TYPES OF MATERIALS

Conductors

- Electrical current flows easily
- Can be grounded

Materials that easily transfer electrons (or charge) are called conductors and are said to have "free" electrons. Some examples of conductors are metals, carbon, and the human body's sweat layer.

Grounding works effectively to remove ElectroStatic charges from conductors to ground. However, the item grounded must be

conductive. The other term often used in ESD control is dissipative which is 1×10^4 to less than 1×10^{11} ohms and is sufficiently conductive to remove ElectroStatic charges when grounded.

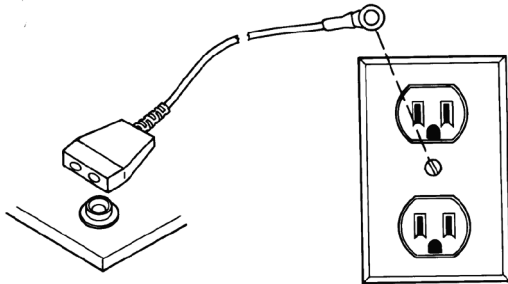

When a conductor is charged, the ability to transfer electrons gives it the ability to be grounded.

Insulators

- Electrical current does not flow easily
- Cannot be grounded

Materials that do not easily transfer electrons are called insulators, by definition non-conductors. Some well known insulators are common plastics, and glass. An insulator will hold the charge and cannot be grounded and “conduct” the charge away.

Both conductors and insulators may become charged with static electricity and discharge. Grounding is a very effective ESD control tool, however, only conductors (conductive or dissipative) can be grounded.

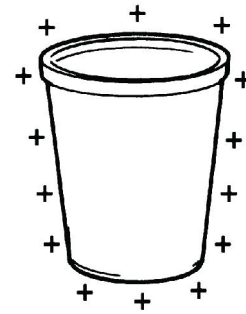

Insulators like this plastic cup will hold the charge and cannot be grounded and “conduct” the charge away.

THINK OF STATIC ELECTRICITY AS GERMS AND CONTAMINATION!

Daily life has other examples of hidden enemies where careful procedures must be followed to regularly obtain positive results. One example is sterilization, which combats germs and contamination in hospitals.

Damage caused by invisible and undetectable events can be understood by comparing ESD damage to medical contamination of the human body by viruses or bacteria. Although invisible, they can cause severe damage. In hospitals, the defense against this invisible threat is extensive contamination control procedures including sterilization.

Per ESD Handbook ESD TR20.20-2008 section 2.5 Material Electrical Characteristics - Insulative, Conductive and Static Dissipative "Virtually all materials, including water and dirt particles in the air, can be triboelectrically charged. An insulator is a material that prevents or limits the flow of electrons across or through its volume is called an insulator. A considerable amount of charge can be formed on the surface of an insulator.

A conductive material allows electrons to flow easily across its surface. Conductive materials have low electrical resistance. If the charged conductive material makes contact with another conductive material, the electrons will transfer between the materials quite easily. If the second conductor is a wire lead to an earth grounding point, the electrons will flow to or from ground and the excess charge on the conductor will be "neutralized".

Static dissipative material will allow the transfer of charge to ground or to other conductive objects. The transfer of charge from a static dissipative material will generally take longer than from a conductive material of equivalent size."

There is no correlation between resistance measurements and the ability of a material to be low charging. Static dissipative material shall have a surface resistance of greater than or equal to 1.0×10^4 ohms but less than 1.0×10^{11} ohms. Conductor less than 1.0×10^4 , and non-Conductor or Insulator 1×10^{11} ohms or higher. (Reference ANSI/ESD S541 section 7.2)

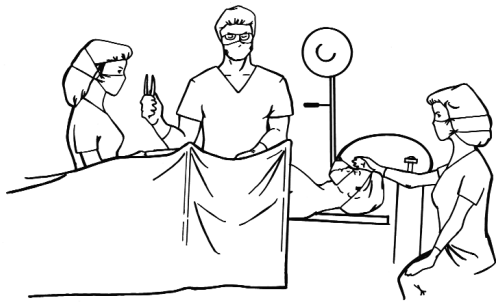

Just as you would never consider having surgery in a contaminated operating room, you should never handle, assemble, or repair electronic assemblies without taking adequate protective measures against ESD.

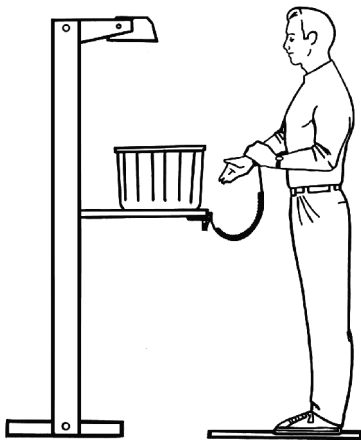

We are aware of the benefits of sterilization in medicine. We must develop the same attitude towards ESD control and “sterilize” against its contamination. Just as you would never consider having surgery in a contaminated operating room, you should never handle, assemble, or repair electronic assemblies without taking adequate measures against ESD. For the hospital to sterilize most of the instruments is not acceptable; actually it may waste money. Each and every instrument needs to be sterilized. Likewise, it is not acceptable to protect the ESDS most of the time. Effective ESD control must occur at each and every step where ESDS is manufactured, processed, assembled, installed, packaged, labeled, serviced, tested, inspected, transported, or otherwise handled.

OPERATOR’S PART IN ESD CONTROL

As an employee, the invisible threat of ESD should be of great concern to you. ESD damage can significantly reduce your company’s profitability. This may affect your company’s ability to compete in the marketplace, your profit sharing, and even your employment. Everyone likes to take pride in their work, but without proper ESD controls, your best efforts may be destroyed by ElectroStatic discharges that you can neither feel nor see.

People in the high-tech manufacturing environment are still a major source of ElectroStatic charges and discharges. Operators need training and to be vigilant that ESD control procedures are followed. In order for the ESD control program to be effective, operators must be aware of the threat of ESD, and understand and adhere to the rules of controlling static electricity, and how to properly use EPA ESD control items.

EPA ESD control items are ESD protective products that have been specially formulated to possess at least one of the ESD control properties:

- 1) low charging (antistatic)
- 2) resistance (conductive or dissipative, able to be grounded)
- 3) shielding.

These products should be identified by the ESD Protective Symbol. Note: the ESD Protective Symbol has an arc which the ESD Susceptibility Symbol does not.

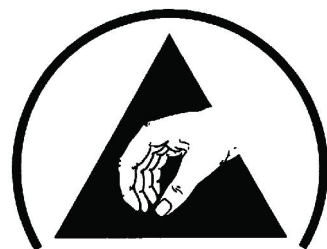

The ESD Protective Symbol identifies products designed to provide ESD control protection.

FUNDAMENTAL ESD CONTROL PRINCIPLES

- Ground all conductors including people
- Remove insulators, substitute with ESD protective versions, or neutralize with ionizers
- ESDS outside the EPA to be in packaging having ESD shielding property

PERSONNEL GROUNDING

A fundamental principle of ESD control is to ground conductors including people at ESD protected workstations. Wrist straps are the first line of defense against ESD, the most common personnel grounding device used, and are required to be used if the operator is sitting. The wristband should be worn snug to the skin with its coil cord connected to a common point ground which is connected to ground, preferably equipment ground.

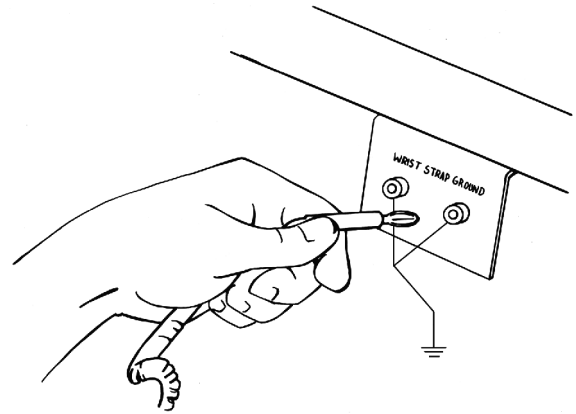
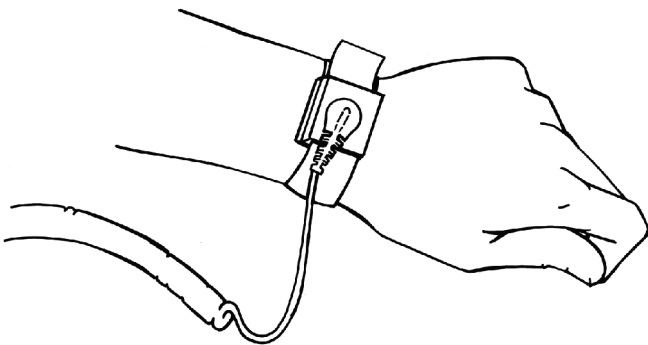

If you are not using a continuous or a constant monitor, a wrist strap should be tested while being worn at least daily. This quick check can determine that no break in the path-to-ground has occurred. Part of the path-to-ground is the perspiration layer on the person; an operator with dry skin may inhibit the removal of static charges and may cause a test failure.

Specially formulated lotion can solve this problem. Failures may also be caused by dirty or loose wristbands which should be cleaned or tightened. When a wrist strap fails a test, the supervisor should be contacted, and the failure effectively addressed or the wrist strap replaced.

A Flooring / Footwear system is an alternative for personnel grounding for standing or mobile workers. Foot grounders or other types of ESD footwear are worn while standing or walking on an ESD floor. ESD footwear is to be worn on both feet and should be tested independently at least daily while being worn. Unless the tester has a split footplate, each foot should be tested independently, typically with the other foot raised in the air.

Per ANSI/ESD S20.20-2007 Foreword "The fundamental ESD control principles are:

- *All conductors in the environment, including personnel, must be attached to a known ground*
- *Necessary non-conductors in the environment cannot lose their electrostatic charge by attachment to ground. Ionization systems provide neutralization of charges on these necessary non-conductive items (circuit board materials and some device packages are examples of necessary non-conductors).*
- *Transportation of ESDS items outside of an ESD Protected Area requires enclosure in static protective materials... Outside an EPA, low charging and static discharge shielding materials are recommended."*

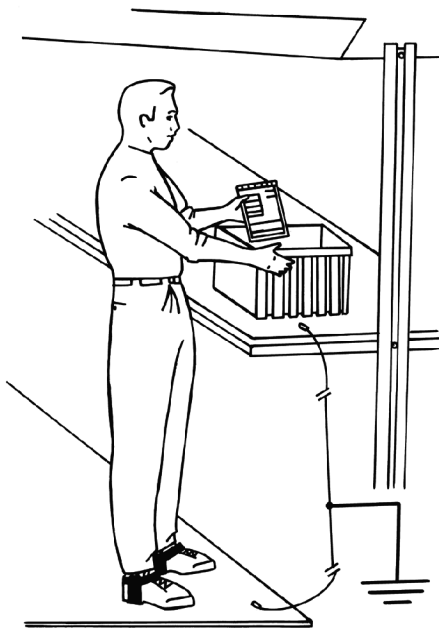

ATTENTION
TEST STATIC GROUND DEVICES HERE
TEST YOUR FOOT GROUND AND WRIST GROUND OFTEN

FOOT GROUND TEST:
 1. STEP ON BAGE WITH ONE FOOT ONLY
 2. TOUCH METAL PAD ON TESTER
 3. CHECK LED INDICATOR "GOOD" TEST
 4. REPEAT WITH OTHER FOOT

WRIST STRAP TEST:
 1. PLUS CHECK WITH BATTERY JACK
 2. DO NOT STEP ON MAT
 3. TOUCH METAL PAD ON TESTER
 4. GREEN LED INDICATES "GOOD" TEST



Both ESD footwear and ESD floor are required. Wearing ESD footwear on a regular, insulative floor is a waste of time and money.

Part of the path-to-ground is the perspiration in the person's shoes. Foot grounder conductive tabs or ribbons should be placed inside the shoe under the foot with the excess length tucked into the shoe. Thanks to the perspiration in the shoe, direct contact with the skin is normally not necessary.

If an operator leaves the EPA and walks outside wearing ESD footwear, care should be taken not to get the ESD footwear soiled. Dirt is typically insulative, and the best practice is to re-test the ESD footwear while being worn each time when re-entering the EPA.

WORKSTATION GROUNDING DEVICES

ESD worksurfaces, such as mats, are typically an integral part of the ESD workstation, particularly in areas where hand assembly occurs. The purpose of the ESD worksurface is two-fold. (1) To provide a surface with little to no charge on it. (2) To provide a surface that will remove ElectroStatic charges from conductors (including ESDS devices and assemblies) that are placed on the surface.

ESD mats need to be grounded. A ground wire from the mat should connect to the common point ground which is connected to ground, preferably equipment ground. For electronics manufacturing a worksurface resistance to ground (RTG) of 1×10^6 to less than 1×10^9 ohms is recommended.

"The wrist strap system should be tested daily to ensure proper electrical value. Nominally, the upper resistance reading should be ≤ 10 megohms or a user defined value. Daily testing may be omitted if constant monitoring is used. NOTE: Integrated Wrist Strap Checker's operation should be verified per the manufacturer's instructions." [ANSI/ESD S1.1 Annex A, 3 Frequency of Functional Testing]

"Compliance verification should be performed prior to each use (daily, shift change, etc.). The accumulation of insulative materials may increase the foot grounder system resistance. If foot grounders are worn outside the ESD protected area testing for functionality before reentry to the ESD protected area should be considered." [ESD SP9.2 APPENDIX B - Foot Grounder Usage Guidance]

Best practice is that ground connections use firm fitting connecting devices such as metallic crimps, snaps and banana plugs to connect to designated ground points. Use of alligator clips is not recommended.

Operators should ensure that the worksurface is organized to perform work, and that all unnecessary insulators and personal items are removed. Regular plastics, polystyrene foam drink cups and packaging materials, etc. are typically high charging and have no place at an ESD protective workstation.

Insulators can be a considerable threat to your products. Remember that an insulator cannot be

grounded so it will retain its charge for a long time. Removing all non-essential insulators from the ESD protective workstation is an important rule. If not, the company's investment in the grounded ESD worksurface may be wasted. If you do not believe so, please read the following paragraph.

The biggest threat is Field Induced Discharges, which can occur even at a properly grounded ESD worksurface. If an ESDS is grounded in the presence of an ElectroStatic charge, instead of the ESDS having charges removed from it, the ESDS may become charged with a voltage induced on it. Then, when placed on the grounded ESD worksurface, a discharge occurs.

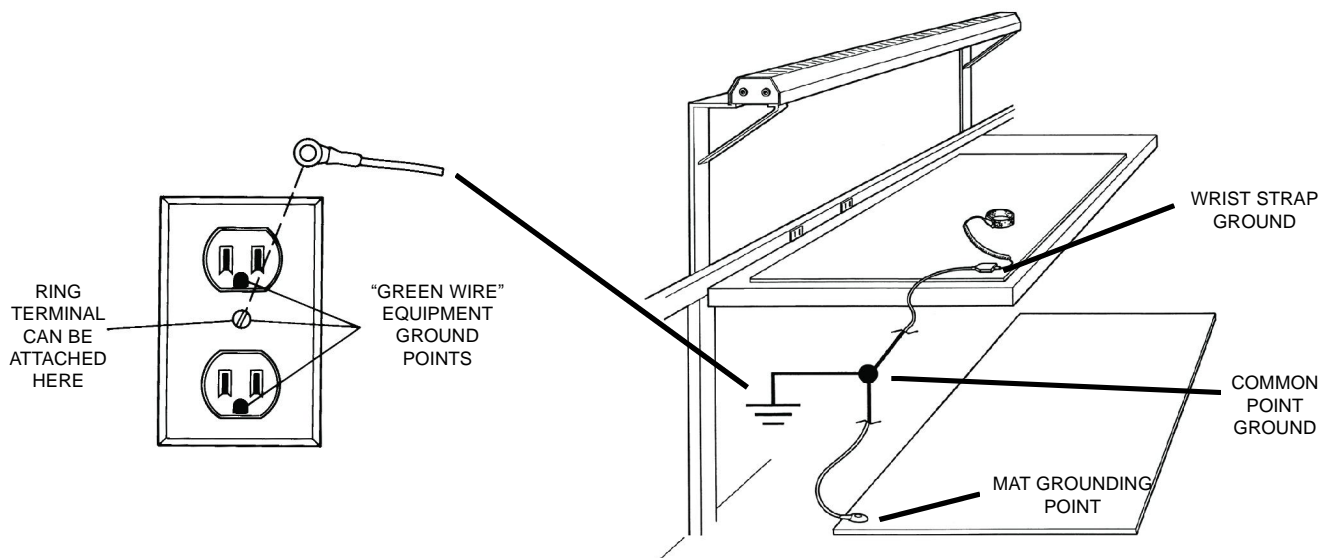

"The single most important concept in the field of static control is grounding. Attaching all electrically conductive and dissipative items in the workplace to ground allows built-up electrostatic charges to equalize with ground potential. A grounded conductor cannot hold a static charge." [Grounding ANSI/ESD S6.1 Foreword]

Per ANSI/ESD S20.20 section 6.2.1.2 Grounding / Bonding Systems Guidance, "In most cases, the third wire (green) AC equipment ground is the preferred choice for ground."

Per ESD Handbook ESD TR20.20-2008 section 5.3.1.7 Electrical Considerations "[RTG is] The most important functional consideration for worksurfaces. This establishes the resistance of the primary path to ground for items, placed on the surface. When worksurface materials are being selected, consideration should be given to possible Charged Device Model (CDM) damage to ESD sensitive products. If CDM damage is a concern then setting a lower resistance limit for the worksurface should be considered. Typically, the lower limit for these types of worksurfaces is 1×10^6 ohms."

ESD Handbook ESD TR20.20-2008 section 5.3.1.14 Maintenance "Periodic cleaning, following the manufacturer's recommendations, is required to maintain proper electrical function of all worksurfaces. Ensure that cleaners that are used do not leave an electrically insulative residue common with some household cleaners that contain silicone."

If the ESDS is removed from the presence of the ElectroStatic charge and grounded again, a second discharge may occur. (Ref. ESD Handbook, ESD TR20.20, section 2.7.5).

The worksurface must be maintained and should be cleaned with an ESD cleaner. Regular cleaners typically contain silicone, and should never be used on an ESD worksurface. The ESD control plan should require testing the resistance to ground periodically. However, the operator should be on guard every day and check visually that the ground wire is attached.

IONIZERS AND NEUTRALIZATION

An ionizer creates great numbers of positively and negatively charged ions. Fans help the ions flow over the work area. Ionization can neutralize static charges on an insulator in a matter of seconds, thereby reducing their potential to cause ESD damage.

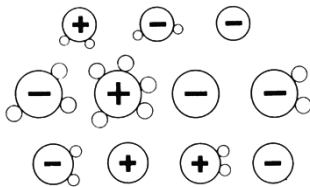

A fundamental principle of ESD control is to neutralize process essential insulators with ionizers. In addition, if a conductor is not grounded, it is an isolated conductor, and an ionizer is the only means to neutralize ElectroStatic charges on it.

Insulators, by definition, are non-conductors and therefore cannot be grounded. Besides neutralization using ionizers, insulators can be controlled by doing the following:

- Keep insulators a minimum of 12" from ESDS items at all times, or
- Replace regular insulative items with an ESD protective version, or
- Periodically apply a coat of topical antistat

When none of the above is possible, the insulator is termed "process essential" and therefore neutralization using an ionizer should become a necessary part of the ESD control program.

Examples of some common process essential insulators are a PC board substrate, insulative test fixtures, and product plastic housings. An example of isolated conductors can be conductive traces or components loaded on a PC board that is not in contact with the ESD worksurface.

Reduction of charges on insulators does occur naturally by a process called neutralization. Ions are charged particles that are normally present in the air, and as opposite charges attract, charges will be neutralized over time

A common example is a balloon rubbed against clothing and "stuck" on a wall by static charge. The balloon will eventually drop. After a day or so natural ions of the opposite charge that are in

"All nonessential insulators such as coffee cups, food wrappers and personal items shall be removed from the workstation or any operation where unprotected ESDS items are handled." [ANSI/ESD S20.20-2007 section 8.3]

Per ESD Handbook ESD TR20.20-2008 Ionization, section 5.3.6.1 Introduction and Purpose / General Information "The primary method of static charge control is direct connection to ground for conductors, static dissipative materials, and personnel. A complete static control program must also deal with isolated conductors that cannot be grounded, insulating materials (e.g. most common plastics), and moving personnel who cannot use wrist or heel straps or ESD control flooring or footwear.

Air ionization is not a replacement for grounding methods. It is one component of a complete static control program. Ionizers are used when it is not possible to properly ground everything and as backup to other static control methods."

the air will be attracted to the balloon and will eventually neutralize the charge. An ionizer greatly speeds up this process.

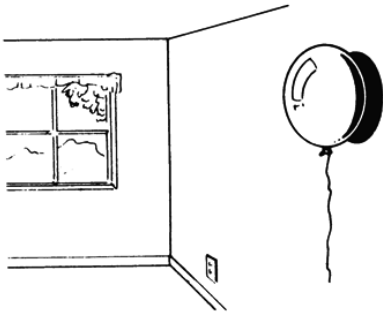

Note: Ionizers require periodic cleaning of emitter pins and the offset voltage must be kept in balance. Otherwise, instead of neutralizing charges, if it is producing primarily positive or negative ions, the ionizer will place an electrostatic charge on items that are not grounded.

SHIELDING

The third fundamental principle of the ESD control system is to package ESD sensitive components and assemblies during storage or transportation outside the EPA enclosed in packaging that possesses the ESD control property of shielding. In shielding, we utilize the fact that electrostatic charges and discharges take the path of least resistance. The charge will be either positive or negative; otherwise the charge would balance out and be no charge. Like charges repel and so the electrostatic charge will reside on the outer surface.

"The normal stable structure of the atom shows that unlike charges attract and like charges repel. Therefore, a separated charge will be self-repellent and will reside only on the surface of a charged item. If the item were a perfect insulator or perfectly insulated, a separated charge would remain indefinitely. Since there are no perfect insulators and it is impossible to have perfect isolation, charges tend to leak away to join opposite charges in the immediate environment thus returning the item to an electrically balanced state. Taking all of the above into account, static electricity is the set phenomena associated with electrical charges on the surface of an insulator or insulated conductive body." [ESD Handbook ESD TR20.20-2008 section 2.3 Nature of Static Electricity]

Per ADV1.0 Glossary Electrostatic discharge shield "A barrier or enclosure that limits the passage of current and attenuates an electromagnetic field resulting from an electrostatic discharge."

A Faraday Cage effect can protect ESDS contents in a shielding bag, or other container with a shielding layer. This Faraday Cage effect protects people in real life when a lightning bolt strikes an airplane or automobile with the charge residing on the outer metal fuselage or car body.

The Faraday cage effect causes charges to be conducted around the outside the surface of the conductor. Since like charges repel, charges will rest on the exterior.

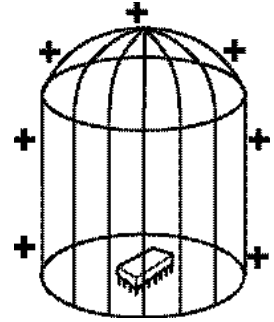

To complete the enclosure, make sure to place lids on boxes or containers, and close shielding bags. Packaging with holes, tears, or gaps should not be used as the contents may be able to extend outside the enclosure and lose their shielding as well as mechanical protection.

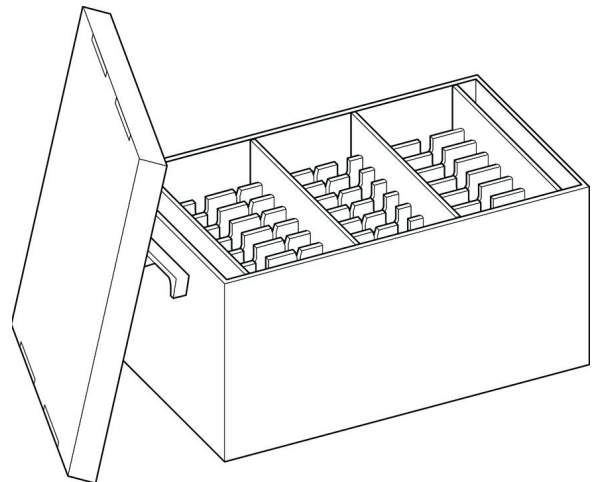

Cover must be in place to create Faraday Cage and shield contents.

When ESD sensitive items are unpackaged from shielding bags or other containers, they should be handled by a grounded operator at an ESD workstation.

ESD WORKSTATIONS

An EPA might be one ESD workstation, an area that has been established to effectively control ESD. At an ESD workstation, we attempt to limit electrostatic charges by grounding all conductors (including people), removing all insulators (or substituting with ESD protective versions), or neutralizing process essential insulators with an ionizer.

ADDITIONAL EPA ESD CONTROL ITEMS

In addition to conductive and dissipative worksurfaces, personnel grounding devices and ionizers, your company may provide a variety of additional ESD control materials.

The proper use of these materials will enhance your company's ESD control program.

Regular versions of these products have been changed to be low charging and/or groundable:

- ESD smocks and gloves
- ESD packaging, bags and boxes
- Conductive foam and shunt bars
- Antistatic or low charging tape
- ESD cleaners and topical antistat
- Dissipative bottles and cups
- Dissipative binders
- Dissipative document and badge holders
- Dissipative floor finishes
- Conductive paint and epoxy
- Conductive and dissipative flooring
- ESD hand lotion

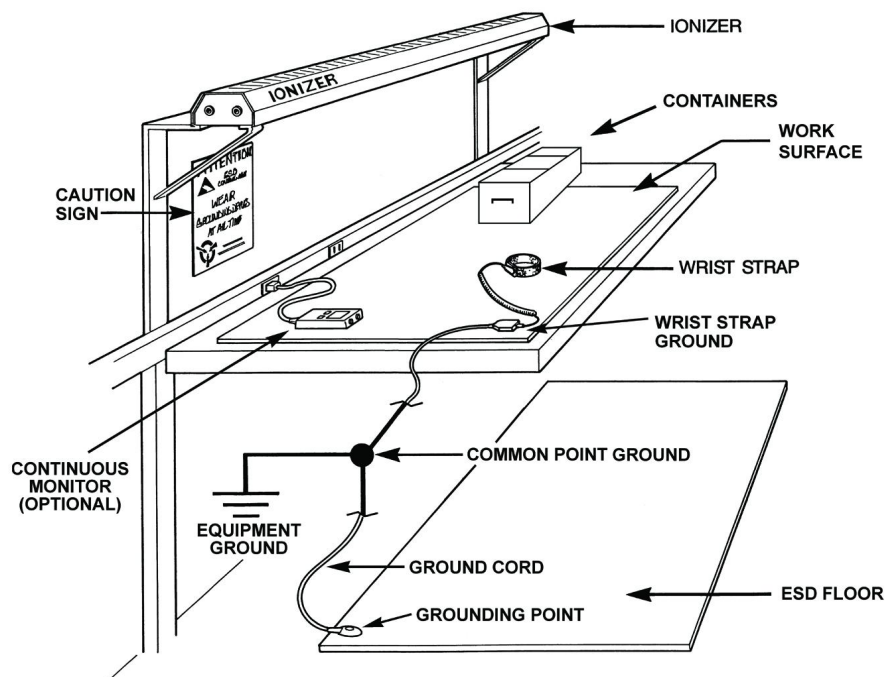

Per ESD Handbook ESD TR20.20-2008 section 2.4 "It should be understood that any object, item, material or person could be a source of static electricity in the work environment. Removal of unnecessary nonconductors, replacing nonconductive materials with dissipative or conductive materials and grounding all conductors are the principle methods of controlling static electricity in the workplace, regardless of the activity."

HANDLING CLASS 0 ESD SENSITIVE ITEMS

CLASS ZERO

ANSI/ESD S20.20 guides a user to enact an ESD Control Program to handle ESD sensitive items with a withstand voltage of 100 volts Human Body Model (HBM) or greater. Per ANSI/ESD STM5.1 Table1 - HBM ESDS Component Classification Class 0 has a Voltage Range less than 250 volts.

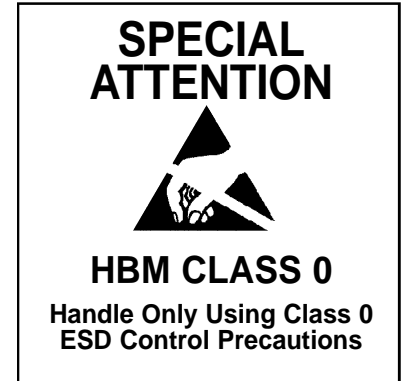

If you handle Class 0 ESDS items, to decrease the probability of ESD damage, additional precautions may be required including additional and/or more stringent technical requirements for EPA ESD control products, increasing redundancies, and more frequent periodic verifications or audits. Additionally, ESD control process systems should be evaluated as to their performance as a system. You will need to understand how the technical elements in use perform relative to the sensitivity of the devices being handled. Thus, tailoring the process to handle the more sensitive parts.

For example: If the footwear/flooring allows a person's body voltage to reach say 80 volts and a 50 withstand voltage item gets introduced into the process, you will either have to allow only handling via wrist straps or would have to find a way to modify the footwear/flooring performance to get peak voltages below the 50 volt threshold. Class Zero Workstations may be identified, and additional measures may include:

IONIZATION

- More stringent removal of non essential items from the workstation
- Ionization to reduce charges on isolated conductors like devices on PCB's
- Ionization to reduce induction charging from process essential insulators
- More stringent Offset Voltage (Balance) and/or faster Discharge times
- Use of Ionizers with feed-back mechanisms and out of balance alarms

GROUNDING

- Use Continuous Monitors to verify proper grounding of operator and worksurface
- Specify more stringent resistance technical requirements such as 10^6 - 10^8 ohm dissipative worksurface
- Require conductive ESD Floor (Per ANSI/ESD S7.1 $< 1 \times 10^6$ ohms)
- Require more reliable ESD footwear such as full coverage foot grounders (as opposed to heel grounders)
- Require improved grounding (using positive mechanical attachments) of carts, shelves, and equipment to ground
- Require dissipative material for all fixtures

SHIELDING

- Use ESD Smocks to shield ESD sensitive items from charges on operator clothing
- Use ESD packaging with shielding properties to store and transport ESDS both within and outside the ESD protected area

Other steps may include minimizing electrostatic charge generation, converting production supplies to ESD protective versions, or treating with topical antistat, requiring dissipative material, increasing training, and frequency of periodic checks per Compliance Verification ESD TR 53.

ESD BASICS (Leadperson Level) QUIZ - True or False

1	An example of Electro Static Discharge or ESD is the zap one sometimes feels after walking across carpeting and touching a metal doorknob.
2	Static Charges are generated when two surfaces contact and separate. Electrons move from one surface to another causing an imbalance. The surface with a deficiency of electrons has a positive charge and the surface with an excess of electrons has a negative charge.
3	ElectroStatic charges eventually will come into balance, but when this occurs suddenly an ESD or ElectroStatic Discharge event occurs. However, this event cannot melt electronic circuitry.
4	A powerful example of an ESD event, creating lots of heat and light, is lightning.
5	Conductors are a type of material where electrical current flows easily so it can be grounded. Examples of conductors include plastics and Styrofoam cups.
6	Insulators are a type of material where electrical current does not flow easily that cannot be grounded. Examples of insulators include metals and people.
7	A person walking across a carpeted floor can generate a voltage, but not greater than 100 volts of electrostatic charge on their body.
8	Charges on a person frequently discharge, but for the person to feel the zap, a discharge must be about 2,000 volts.
9	In manufacturing handling electronic components, ESD is the hidden enemy as there can easily be damaging ElectroStatic discharges that a person cannot see or feel.
10	Passing an inspection test means that the ESD sensitive item (ESDS) has experienced a catastrophic ESD failure.
11	Passing an inspection test means that the ESD sensitive item (ESDS) has not experienced a latent ESD defect.
12	Although passing all inspections in the factory, ESDS items having latent defects and failing in the field can be very expensive in warranty expense, field service repairs, and loss of customer satisfaction.
13	Manufacturing ESD sensitive items without proper ESD control is like a physician conducting surgery on you without following sterilization procedures.
14	A person can be charged, and as a conductor, should be grounded at the ESD protective workstation. Always be grounded when handling unpackaged ESD sensitive items; and always wear a wrist strap when seated at an ESD protected workstation.
15	Make sure to always ground insulators.
16	Even if it adversely effects the quality of the products you are working on, allow strangers into the work area and handle products as they please.
17	If the air flow of the ionizer bothers you, it's OK to direct it away from the products you are working on.
18	Regular plastic bags are high charging insulators and should not be permitted in an ESD protected area.
19	ESD Shielding Bags, if closed, will keep electrostatic charges on the exterior of the bag, and being dissipative, the charge will be removed when handled by a grounded person or placed upon a properly grounded ESD Worksurface.
20	Wrist Straps and ESD footwear should be tested at least daily, and while wearing them. You should notify your supervisor if a failure occurs.
21	ESD Foot Grounder grounding tabs should be cut off.
22	ESD Smocks shield ESDS items from charges on your clothing. Most clothing is insulative and these charges cannot be removed via your wrist strap. Make sure to button up ESD Smock covering all clothing.
23	The ESD Association understands that high charging personal items should be allowed in an ESD protected area, even if they might damage products.
24	Only trained or escorted people should be allowed in an ESD protected area.
25	Use ESD packaging having shielding property to store or transport ESD sensitive items outside an ESD protected area.

ESD BASICS (Assembler Level) QUIZ

Please answer the following questions by circling the correct letter.

1. Electrostatic charges are generated:

- A. By heat
- B. By high humidity
- C. When 2 surfaces contact then separate

2. When a "zap" is felt by a person, the voltage of the ElectroStatic Discharge (ESD) has to be about:

- A. 200 volts
- B. 2,000 volts
- C. 20,000 volts

3. The first line of defense against ESD is:

- A. The Ionizer
- B. The foot grounder
- C. The wrist strap

4. Some of today's ESD sensitive devices can be damage by as little as:

- A. 100 volts
- B. 800 volts
- C. 3,000 volts

5. If not using continuous monitors, wrist straps should be tested at least:

- A. Daily
- B. Weekly
- C. Monthly

6. When transporting or storing ESD sensitive devices outside the ESD protected area, the devices should be in packaging that includes:

- A. Grounding
- B. Shielding
- C. Ionizing

7. Materials that are non-conductors cannot be grounded; they are also called:

- A. Dissipative
- B. Conductors
- C. Insulators

8. To neutralize ElectroStatic charges on insulators, use:

- A. Ground cords
- B. Conductive mats
- C. Ionizers

9. An ESD protective worksurface mat should be:

- A. Grounded
- B. Clear of nonessential insulators
- C. Cleaned only with an ESD cleaner
- D. All of the above

10. Wrist Strap Band should be:

- A. Snug on skin around the wrist
- B. Removed if a nuisance
- C. Placed over shirt sleeve

11. Foot Grounders, if used, should be tested at least daily; the grounding tab should be:

- A. Cut off
- B. Placed in shoe under your foot
- C. Tied around your finger

12. An ESD smock shields product you are working on from charges on your clothing. Front panels should be:

- A. Closed covering all clothing on torso
- B. Left wide open
- C. Tied calypso style

13. In the workplace, ESD is an hidden enemy, you may want to think of it as a form of:

- A. Combustion, like where there's smoke there's fire
- B. Corruption, like money and politicians
- C. Contamination, like germs in an hospital operating room

14. Insulators, not needed to do your job, such as drinking cups, regular tape, picture frames, radio enclosures, etc. should be:

- A. Allowed to induce charges on ESD sensitive products
- B. Color coded for identification
- C. Removed from the ESD protective workstation

15. ESD control products are often regular products that have at least one ESD control property added. Examples are:

- A. ESD smocks
- B. ESD packaging, bags and boxes
- C. Dissipative document holders
- D. All of the above

For quiz answers go to:

www.DescolIndustries.com/pdf/assembler.pdf

www.DescolIndustries.com/pdf/leadperson.pdf

Desco Industries Inc. brands include:

Manufacturer of ESD Static
Control Products

DESCO

Desco.com

For European designed
ESD products

CHARLESWATER

Charleswater.co.uk

ESD
Control Packaging Solutions

PROTEKTIVE PAK

ProtectivePak.com

Everything you need for your
ESD Control Program

ESD SYSTEMS.com

ESDSystems.com

ESD Monitoring, Ionization &
Test

EMIT

DescoEmit.com

For specialty workstation tools

MENDA

MendaPump.com

The specialists for ESD protection

Vermason

Vermason.co.uk

**FOR ESD CONTROL
GO TO WEBSITES TO VIEW CATALOGS OR REQUEST
A PRINTED CATALOG OR SAMPLE**

**For other important ESD information on our web sites
see Technical, Resources and ESD Information tabs**

"Process monitoring (measurements) shall be conducted in accordance with a Compliance Verification Plan that identifies the technical requirements to be verified, the measurement limits and the frequency at which those verifications shall occur. The Compliance Verification Plan shall document the test methods and equipment used for process monitoring and measurements. Compliance verification records shall be established and maintained to provide evidence of conformity to the technical requirements. The test equipment selected shall be capable of making the measurements defined in the Compliance Verification Plan." [ANSI/ESD S20.20-2007 section 7.3]

DESCO INDUSTRIES

www.DescoIndustries.com

3651 WALNUT AVENUE, CHINO, CA 91710 • (909) 627-8178 • FAX (909) 627-7449

E-MAIL: Service@DescoIndustries.com