



# Data Sheet: JN5168-001-Myy

## JenNet-IP, ZigBee PRO and IEEE802.15.4 Module

### Overview

The JN5168-001-Myy family is a range of ultra low power, high performance surface mount modules targeted at IEEE 802.15.4, JenNet-IP, ZigBee Light Link, ZigBee Smart Energy and RF4CE networking applications, enabling users to realise products with minimum time to market and at the lowest cost. They remove the need for expensive and lengthy development of custom RF board designs and test suites. The modules use NXP's JN5168 wireless microcontroller to provide a comprehensive solution with large memory, high CPU and radio performance and all RF components included. All that is required to develop and manufacture wireless control or sensing products is to connect a power supply and peripherals such as switches, actuators and sensors, considerably simplifying product development.

Four module variants are available: JN5168-001-M00 with an integrated antenna, JN5168-001-M03 with an antenna connector and the JN5168-001-M05 and M06 with an antenna connector, power amplifier and LNA for extended range. The JN5168-001-M05 output power has been optimised for use in Europe and Asia.

### Module Block Diagram

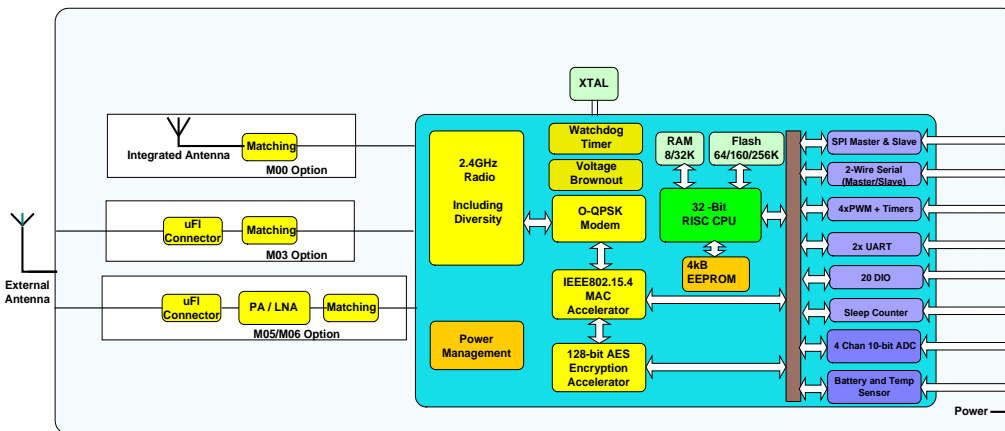

### Benefits

- Microminiature module solutions
- Ready to use in products
- Minimises product development time
- No RF test required for systems
- Compliant with
  - FCC 47CFR Part 15C
  - IC Canada RSS 210 Issue 8 - Annex 8,
  - ETSI EN 300-328 V1.7.1
  - EN 301-489-17 V2.1.1
  - EN60950-1-2006 +A1, A11, A12

### Applications

- Robust and secure low power wireless applications
- ZigBee and JenNet-IP networks
- Home and commercial building automation
- Utilities metering (e.g. AMR)
- Location Aware services (e.g. Asset Tracking)
- Toys and gaming peripherals
- Industrial systems
- Telemetry
- Remote Control

### Features: Module

- 2.4GHz IEEE 802.15.4, JenNet-IP, ZigBee Light Link, ZigBee Smart Energy and RF4CE compatible
- **JN5168-001-M00/03**
  - up to 1km range (Ext antenna)
  - M00: integral antenna 16x30mm
  - M03: uFI connector 16x21mm
    - TX power +2.5dBm
    - Receiver sensitivity -95dBm
    - TX current 15.3mA
    - RX current 17mA
    - 2.0-3.6V operation
- **JN5168-001-M05**
  - up to 2km range (Ext 2dBi Antenna)
    - 9.5 dBm TX Power
    - Receiver sensitivity -96dBm
    - uFI connector
    - TX current 35mA
    - RX current 22mA
    - 16x30mm
    - 2.0-3.6V operation
- **JN5168-001-M06**
  - up to 6km range (Ext 2 dBi Antenna)
    - 22dBm TX Power
    - Receiver sensitivity -100dBm
    - uFI connector
    - TX current 175mA
    - RX current 22mA
    - 16x30mm
    - 2.0-3.6V operation

### Features: Microcontroller

- 32-bit RISC CPU, up to 32MIPs with low power
- Data EEPROM with guaranteed 100k write operations
- RF4CE, JenNet-IP, ZigBee Smart Energy stacks
- JTAG debug interface
- 4-input 10-bit ADC, 1 comparator
- 5 x PWM (4 x timer, 1 x timer/counter)
- 2 UARTs
- SPI Master & Slave port with 3 selects
- 2-wire serial interface
- Battery and Temperature Sensor
- Watchdog timer and BOR
- Up to 20 DIO

**Industrial temp (-40°C to +85°C)**

**Lead-free and RoHS compliant**

---

# Contents

<b>1. Introduction</b>	<b>3</b>
1.1. Variants	3
1.2. Regulatory Approvals	3
<b>2. Specifications</b>	<b>4</b>
2.1. JN5168 Single Chip Wireless Microcontroller	5
<b>3. Pin Configurations</b>	<b>6</b>
3.1. Pin Assignment	7
3.2. Pin Descriptions	8
3.2.1 Power Supplies	8
<b>4. Electrical Characteristics</b>	<b>9</b>
4.1. Maximum Ratings	9
4.2. Operating Conditions	9
<b>Appendix A Additional Information</b>	<b>10</b>
A.1 Outline Drawing	10
A.2 Module PCB Footprint	13
A.3 Optimal PCB placement of the JN5168-001-M00 Module	14
A.4 JN5168-001-M00 Antenna Radiation Pattern	15
A.5 Manufacturing	19
A.5.1 Reflow Profile	19
A.5.2 Soldering Paste and Cleaning	20
A.6 Ordering Information	20
A.7 Related Documents	21
A.8 Federal Communication Commission Interference Statement	21
A.8.1 Antennas approved by FCC for use with JN5168 modules	22
A.8.2 High Power Module usage limitation	22
A.8.3 FCC End Product Labelling	22
A.9 Industry Canada Statement	23
A.9.1 Industry Canada End Product Labelling	23
A.10 European R & TTE Directive 1999/5/EC Statement	23
A.11 RoHS Compliance	24
A.12 Status Information	24
A.13 Disclaimers	24
Version Control	25

---

# 1. Introduction

The JN5168-001-My module family provides designers with a ready-made component that provides a fully integrated solution for applications, using the IEEE802.15.4 standard in the 2.4-2.5GHz ISM frequency band [1], including JenNet-IP and ZigBee Smart Energy, and can be quickly and easily included in product designs. The modules integrate all of the RF components required, removing the need to perform expensive RF design and test. Products can be designed by simply connecting sensors and switches to the module IO pins. The modules use NXP's single chip IEEE802.15.4 Wireless Microcontroller, allowing designers to make use of the extensive chip development support material. Hence, this range of modules allows designers to bring wireless applications to market in the minimum time with significantly reduced development effort and cost.

Four variants are available: JN5168-001-M00, JN5168-001-M03, JN5168-001-M05 and JN5168-001-M06. All modules have FCC and Industry Canada modular approvals. All modules other than the JN5168-001-M06 are also CE compliant and subject to a Notified Body Opinion.

The variants available are described below.

## 1.1. Variants

Variant	Description	FCCID	Industry Canada ID
JN5168-001-M00	Standard Power, integrated antenna	TYOJN5168M0	7438A-CYO5168M0
JN5168-001-M03	Standard Power, uFL connector	TYOJN5168M3	7438A-CYO5168M3
JN5168-001-M05	Medium Power, uFL connector	TYOJN5168M5	7438A-CYO5168M5
JN5168-001-M06	High Power, uFL connector	TYOJN5168M6	7438A-CYO5168M6

## 1.2. Regulatory Approvals

The JN5168-001-M00, M03 and M05 have been tested against the requirements of the following European standards.

- Radio EN 300 328 v1.7.1.
- EMC, EN 301 489-17 v2.1.1
- Basic Safety Assessment (BSA) EN 60950-1:2006

A Notified Body statement of opinion for this standard is available on request.

The High Power module with M06 suffix is not approved for use in Europe, instead the JN5168-001-M05 module may be used with an antenna with up to 2.2dBi; 10mW/MHz power spectral density e.i.r.p is the maximum permitted in Europe.

Additionally, all module types have received FCC "Modular Approval", in compliance with CFR 47 FCC part 15 regulations and in accordance to FCC Public notice DA00-1407. Appendix A.8 contains details on the conditions applying to this modular approval. The modules are approved for use with a range of different antennas; further details of which can be found in section Appendix A.8.1. The modular approvals notice and test reports are available on request.

All modules are compliant with Industry Canada RSS210 (Issue 8, Annex 8) and have Industry Canada modular approval.

The JN5168-001-M06 module is subject to user proximity restrictions under FCC and Industry Canada regulations; more specific information is available in A.8.2.

## 2. Specifications

Most specification parameters for the modules are specified in the chip datasheet - JN-DS-JN5168 Wireless Microcontroller Datasheet [2]. Where there are differences, the parameters are defined here.

VDD=3.0V @ +25°C

Typical DC Characteristics				Notes
	JN5168-001-M00/03	JN5168-001-M06	JN5168-001-M05	
Deep sleep current	100nA	100nA	100nA	
Sleep current	0.70uA	0.70uA	0.70uA	With active sleep timer
Radio transmit current	15.3mA	175mA	35mA	CPU in doze, radio transmitting
Radio receive current	17mA	22mA	22mA	CPU in doze, radio receiving
Centre frequency accuracy	+/-25ppm	+/-25ppm	+/-25ppm	Additional +/-15ppm allowance for temperature and ageing
Typical RF Characteristics				Notes
Receive sensitivity	-95dBm	-100dBm	-96dBm	Nominal for 1% PER, as per 802.15.4 section 6.5.3.3 (Note 1)
Transmit power	2.5dBm	22dBm	9.5 dBm	Nominal
Maximum input signal	10dBm	5dBm	10dBm	For 1% PER, measured as sensitivity
RSSI range	-95 to -10dBm	-105 to -20dBm	-102 to -17dBm	
RF Port impedance – uFL connector	50 ohm	50 ohm	50 ohm	2.4 - 2.5GHz
Rx Spurious Emissions	-61dBm	-69dBm	-69dBm	Measured conducted into 50ohms
Tx Spurious Emissions	-40dBm	-49dBm	-45dBm	Measured conducted into 50ohms
VSWR (max)	2:1	2:1	2:1	2.4 - 2.5GHz
Peripherals				Notes
Master SPI port	3 selects	3 selects	3 selects	250kHz - 16MHz
Slave SPI port	✓	✓	✓	250kHz - 4MHz
Two UARTs	✓	✓	✓	16550 compatible
Two-wire serial I/F (compatible with SMBus & I <sup>2</sup> C)	✓	✓	✓	Up to 400kHz
5 x PWM (4 x timer, 1 x timer/counter)	✓	✓	✓	16MHz clock
Two programmable Sleep Timers	✓	✓	✓	32kHz clock
Digital IO lines (multiplexed with UARTs, timers and	20	18	18	DIO2 & DIO3 not available on JN5168-001-M05 and JN5168-001-M06 modules

SPI selects)				
Four channel Analogue-to-Digital converter	✓	✓	✓	10-bit, up to 100ks/s
Programmable analogue comparators	✓	✓	✓	Ultra low power mode for sleep
Internal temperature sensor and battery monitor	✓	✓	✓	

The performance of all peripherals is defined in the JN-DS-JN5168 Wireless Microcontroller Datasheet [2].

Note 1: Sensitivity is defined for conducted measurements on connectorised modules. Modules with an integrated antenna have approximately 1.5 dB less e.i.r.p and reciprocal receive sensitivity.

NXP supplies all the development tools and networking stacks needed to enable end-product development to occur quickly and efficiently. These are all freely available from [www.nxp.com/jennic](http://www.nxp.com/jennic). A range of evaluation/developer kits is also available, allowing products to be quickly bread boarded. Efficient development of software applications is enabled by the provision of a complete, unlimited, software developer kit. Together with the available libraries for the IEEE802.15.4 MAC and the JenNet-IP and ZigBee PRO network stacks, this package provides everything required to develop application code and to trial it with hardware representative of the final module.

The modules can be user programmed both in development and in production using software supplied by NXP. Access to the on-chip peripherals, MAC and network stack software is provided through specific APIs. This information is available on the NXP support website, together with many example applications, user guides, reference manuals and application notes.

## 2.1. JN5168 Single Chip Wireless Microcontroller

The JN5168-001-My series is constructed around the JN5168-001 single chip wireless microcontroller, which includes the radio system, a 32-bit RISC CPU, Flash, RAM & EEPROM memory and a range of analogue and digital peripherals.

The chip is described fully in JN-DS-JN5168 Wireless Microcontroller Datasheet [2].

---

### 3. Pin Configurations

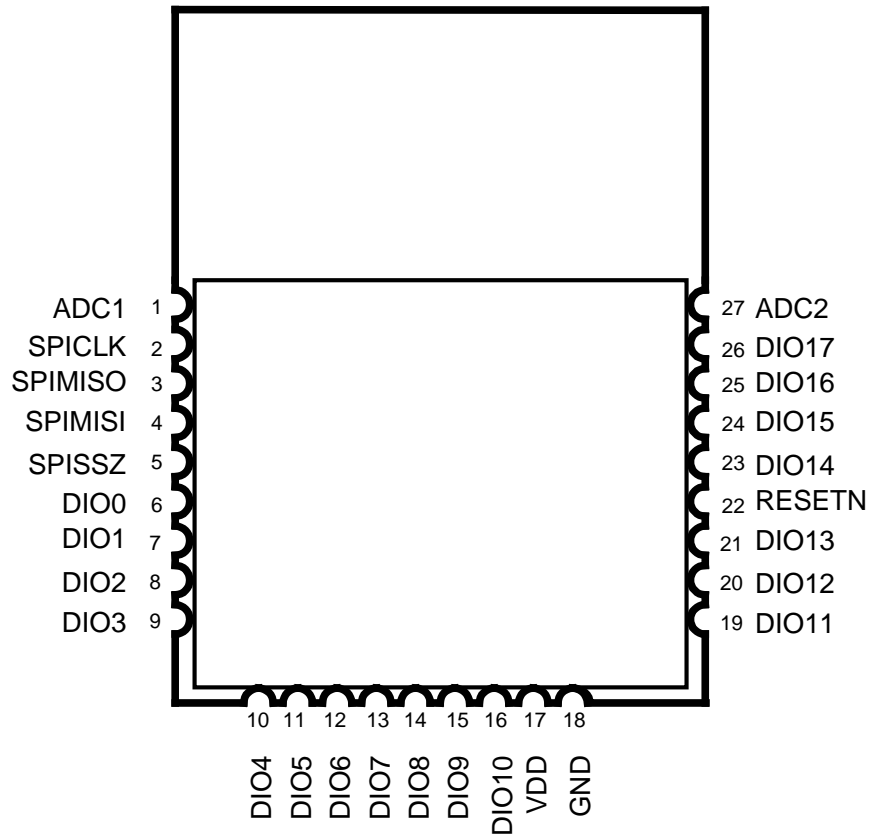

**Figure 1: Pin Configuration (top view)**

Note that the same basic pin configuration applies for all module designs. However, DIO3 (pin 9) and DIO2 (pin 8) are not available on the JN5168-001-M05 and JN5168-001-M06.

## 3.1. Pin Assignment

Pin No	Pin Functions					Signal Type	Description
	Primary	Alternate Functions					
1	ADC1					3.3V	Analogue to Digital Input
2	SPICLK				PWM2	CMOS	SPI Master Clock Output or PWM2 Output
3	SPIMISO					CMOS	SPI Master In Slave Out Input
4	SPIMOSI				PWM3	CMOS	SPI Master In Slave Out Input or PWM3 Output
5	SPISEL0					CMOS	SPI Select From Module – SS0 Output
6	DIO0	SPISEL1	ADC3			CMOS	DIO0, SPI Master Select Output 1 or ADC input 3
7	DIO1	SPISEL2	ADC4	PC0		CMOS	DIO1, SPI Master Select Output 2, ADC input 4 or Pulse Counter 0 Input
8	DIO2*		RFRX	TIM0CK_GT		CMOS	DIO2, Radio Receive Control Output or Timer0 Clock/Gate Input
9	DIO3*		RFTX	TIM0CAP		CMOS	DIO3, Radio Transmit Control Output or Timer0 Capture Input
10	DIO4	CTS0	JTAG_TCK	TIM0OUT	PC0	CMOS	DIO4, UART 0 Clear To Send Input, JTAG CLK Input, Timer0 PWM Output, or Pulse Counter 0 input
11	DIO5	RTS0	JTAG_TMS	PWM1	PC1	CMOS	DIO5, UART 0 Request To Send Output, JTAG Mode Select Input, PWM1 Output or Pulse Counter 1 Input
12	DIO6	TXD0	JTAG_TDO	PWM2		CMOS	DIO6, UART 0 Transmit Data Output, JTAG Data Output or PWM2 Output
13	DIO7	RXD0	JTAG_TDI	PWM3		CMOS	DIO7, UART 0 Receive Data Input, JTAG Data Input or PWM 3 Output
14	DIO8	TIM0CK_GT	PC1	PWM4		CMOS	DIO8, Timer0 Clock/Gate Input, Pulse Counter1 Input or PWM 4 Output
15	DIO9	TIM0CAP	32KXTALIN	RXD1	32KIN	CMOS	DIO9, Timer0 Capture Input, 32K External Crystal Input, UART 1 Receive Data Input or 32K external clock Input
16	DIO10	TIM0OUT	32KXTALOUT			CMOS	DIO10, Timer0 PWM Output or 32K External Crystal Output
17	VDD					3.3V	Supply Voltage
18	GND					0V	Digital Ground
19	DIO11	PWM1		TXD1		CMOS	DIO11, PWM1 Output or UART 1 Transmit Data Output
20	DIO12	PWM2	CTS0	JTAG_TCK	ADO or SPIMOSI	CMOS	DIO12, PWM2 Output, UART 0 Clear To Send Input, JTAG CLK Input, Antenna Diversity Odd Output or SPI Slave Master Out Slave In Input
21	DIO13	PWM3	RTS0	JTAG_TMS	ADE or SPIMISO	CMOS	DIO13, PWM3 Output, UART 0 Request To Send Output, JTAG Mode Select Input, Antenna Diversity Even output or SPI Slave Master In Slave Out Output
22	RESETN					CMOS	Reset input
23	DIO14	SIF_CLK	TXD0 TXD1	JTAG_TDO	SPISEL1 or	CMOS	DIO14, Serial Interface Clock,

					SPISSEL		UART 0 Transmit Data Output, UART 1 Transmit Data Output, JTAG Data Output, SPI Master Select Output 1 or SPI Slave Select Input
24	DIO15	SIF_D	RXD0 RXD1	JTAG_TDI	SPISEL2	CMOS	DIO15, Serial Interface Data or Intelligent Peripheral Data Out
25	DIO16	COMP1P	SIF_CLK	SPISMOSI		CMOS	DIO16, Comparator Positive Input, Serial Interface clock or SPI Slave Master Out Slave In Input
26	DIO17	COMP1M	PWM4	I2C DATA	SPISIMO	CMOS	DIO17, Comparator Negative Input, Serial Interface Data or SPI Slave Master In Slave Out Output
27	ADC2					3.3V	Analogue to Digital Input

\* These two pins are not connected for JN5168-001-M05 & JN5168-001-M06 modules.

## 3.2. Pin Descriptions

All pins behave as described in the JN-DS-JN5168 Wireless Microcontroller Datasheet [2], with the exception of the following:

### 3.2.1 Power Supplies

A single power supply pin, VDD is provided.



---

## 4. Electrical Characteristics

In most cases, the Electrical Characteristics are the same for both module and chip. They are described in detail in the chip datasheet. Where there are differences, they are detailed below.

### 4.1. Maximum Ratings

Exceeding these conditions will result in damage to the device.

Parameter	Min	Max
Device supply voltage VDD	-0.3V	3.6V
All Pins	-0.3V	VDD + 0.3V
Storage temperature	-40°C	150°C

### 4.2. Operating Conditions

Supply	Min	Max
VDD	2.0V	3.6V
Ambient temperature range	-40°C	85°C

# Appendix A Additional Information

## A.1 Outline Drawing

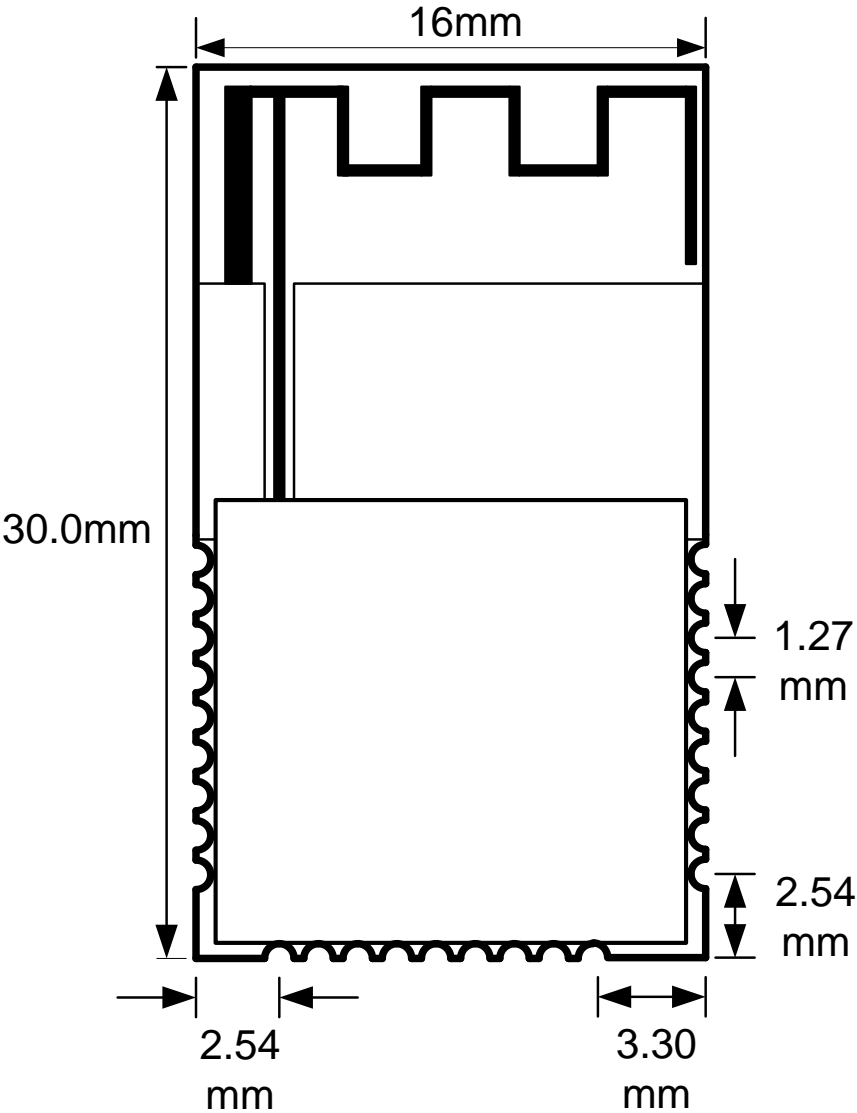

Thickness: 3.5mm

Figure 2 JN5168-001-M00 Outline Drawing

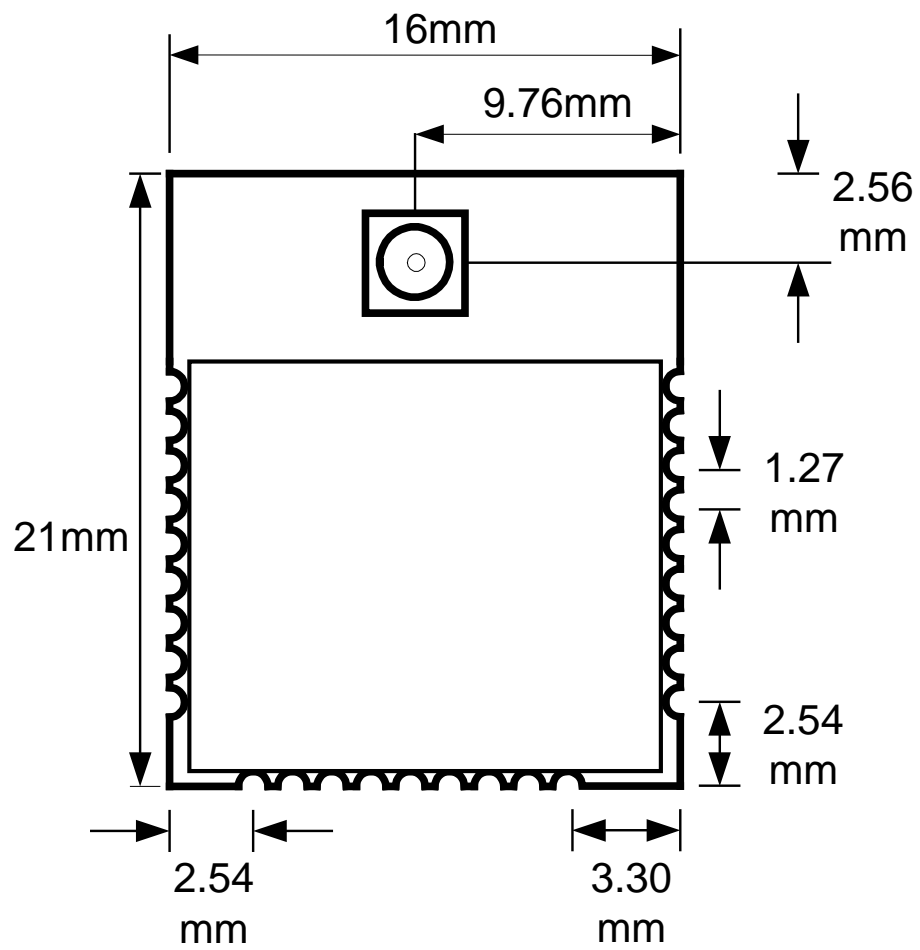

Thickness: 3.5mm

Figure 3 JN5168-001-M03 Outline Drawing

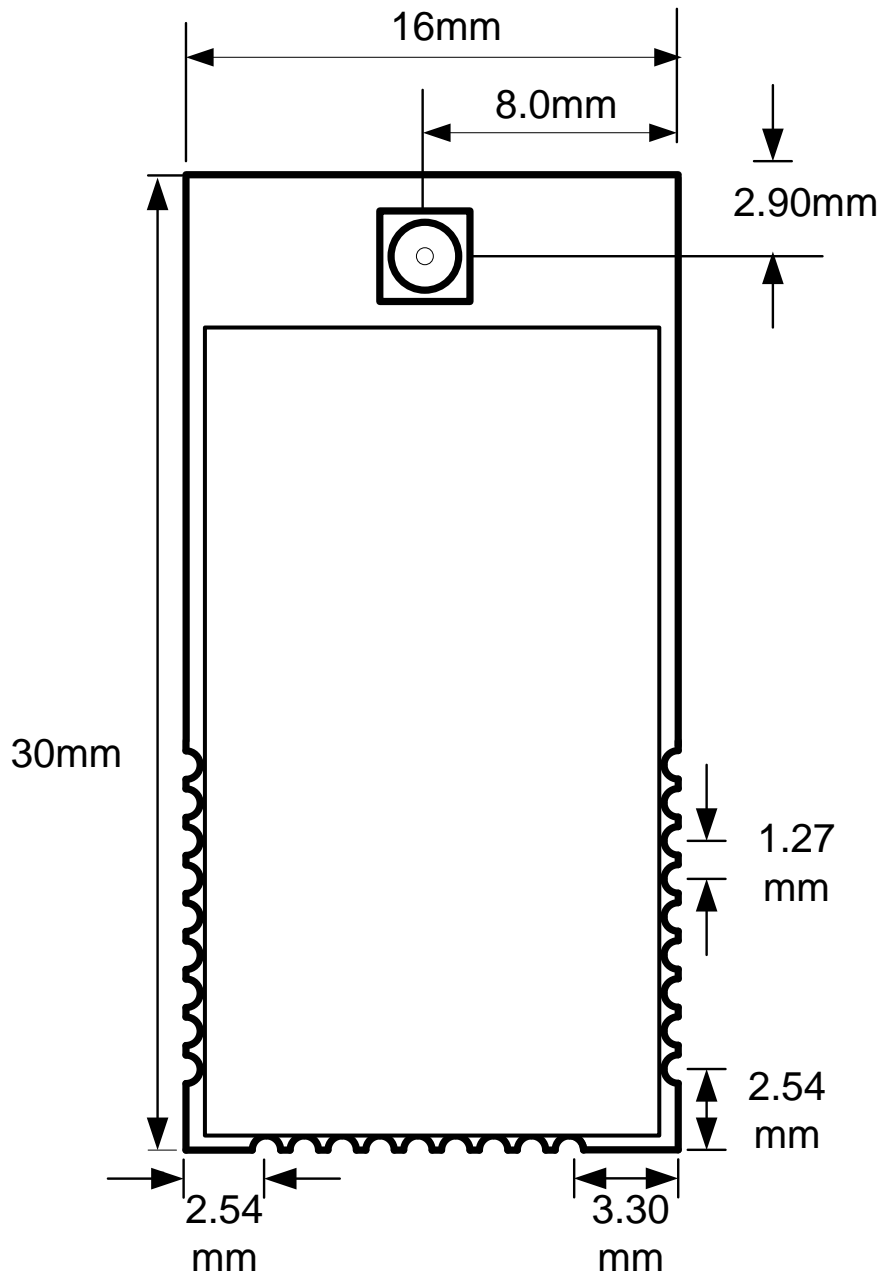

Thickness: 3.5mm

Figure 4 JN5168-001-M05 and JN5168-001-M06 Outline Drawing

## A.2 Module PCB Footprint

All dimensions are in mm.

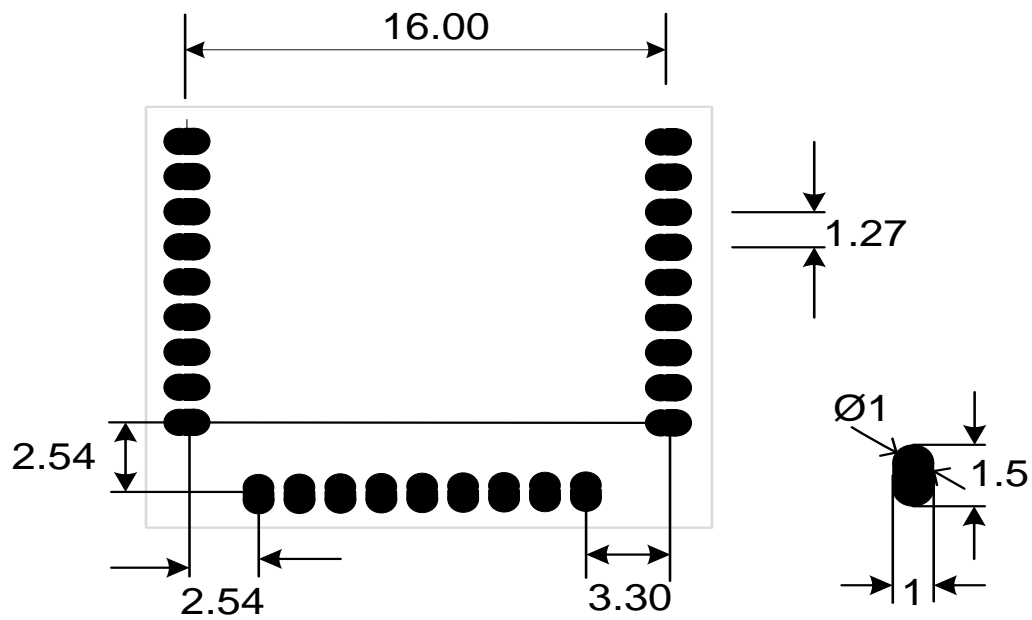

Note: All modules have the same footprint

Figure 5 Module PCB footprint

### A.3 Optimal PCB placement of the JN5168-001-M00 Module

The JN5168-001-M00 module features an optimised, low cost, integrated, inverted F, printed PCB antenna. The antenna has a vertically polarised near omnidirectional radiation pattern and up to 1.6 dBi of peak gain. The PCB design has been elongated in order to increase the ground plane area which increases the antenna efficiency. This allows stand alone operation without any additional ground plane however care must be taken when mounting this module onto another PCB. The area around the antenna must be kept clear of conductors or other metal objects for an absolute minimum of 20 mm. This is true for all layers of the PCB and not just the top layer. Any conductive objects close to the antenna could severely disrupt the antenna pattern resulting in deep nulls and high directivity in some directions.

The diagrams below show various possible scenarios. The top 3 scenarios are correct; groundplane may be placed beneath JN5168-001-M00 module as long as it does not protrude beyond the edge of the top layer ground plane on the module PCB.

The bottom 3 scenarios are incorrect; the left hand side example because there is groundplane underneath the antenna, the middle example because there is insufficient clearance around the antenna (it is best to have no conductors anywhere near the antenna), finally the right hand example has a battery's metal casing in the recommended keep out area.

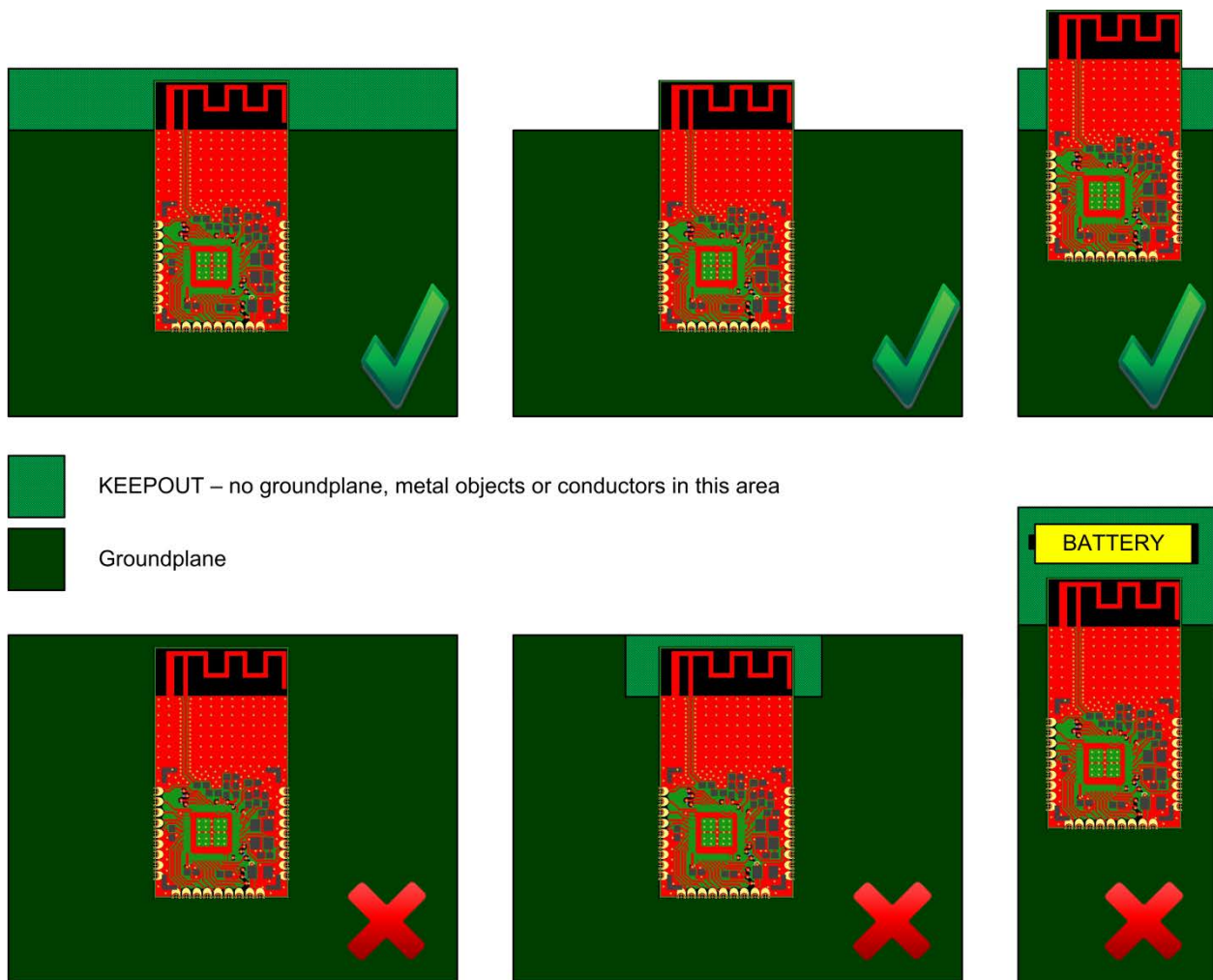
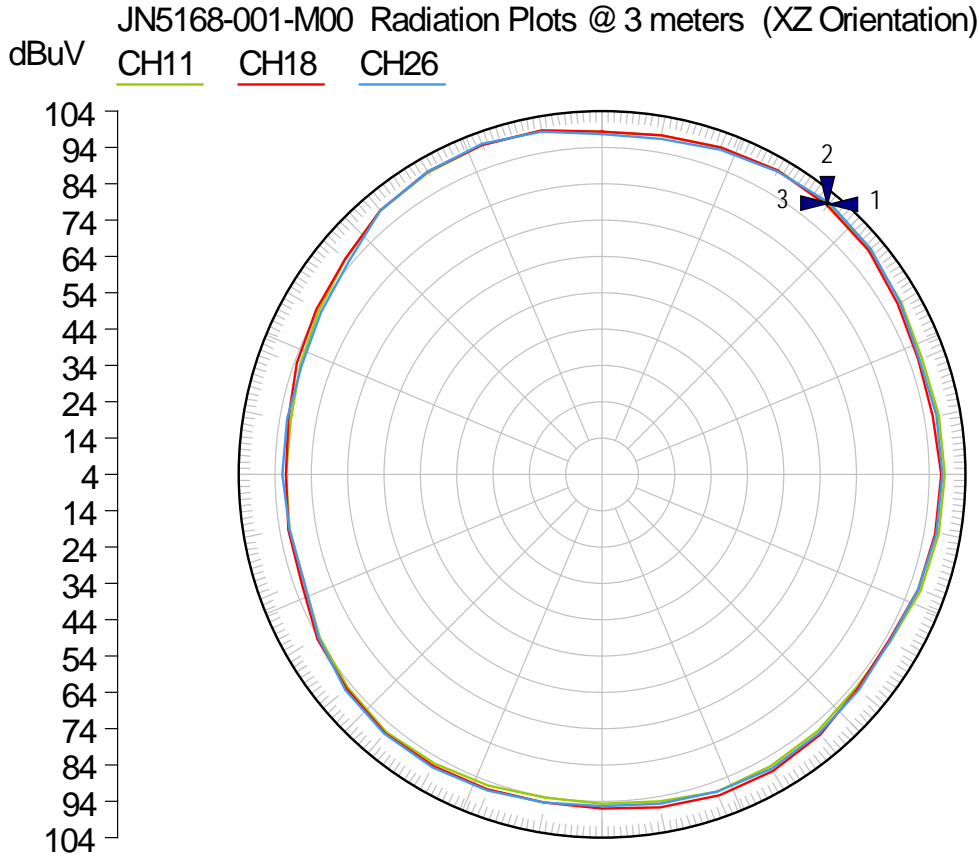

Figure 6 PCB placement of the JN5168-001-M00 Module

## A.4 JN5168-001-M00 Antenna Radiation Pattern

Figure 7, Figure 8 & Figure 9 are simulated 3D radiation plots of the JN5168-001-M00. They are provided here to help the user orientate the module in end equipment in an optimal way. These visualisations are an accurate representation of the antenna radiation pattern in the 3D space.

The 2D XZ plots for each channel are shown in



Mkr	Trace	X-Axis	Value
1 ▼	CH11	40.0 deg	101.04 dBuV
2 ▼	CH18	40.0 deg	100.67 dBuV
3 ▼	CH26	40.0 deg	101.26 dBuV

Figure 10. These are actual measurements in an anechoic chamber with the JN5168-001-M00 mounted on a DR1174 carrier board from the JN516x-EK001 Evaluation kit. The device under test and the antenna height was 1m and the values are in dBuV/m at a distance of 3m.

Figure 11 is a plot of the peak field strengths for a JN5168-001-M00, JN5148-001-M00 and JN5168-001-M03. The M03 is used with a  $\lambda/2$  vertical antenna. Figure 11 shows that the new integrated antenna is 1.5-3dB better than the JN5148-001-M00 and is within 1.5 dB of a JN5168-001-M03  $\lambda/2$  vertical.

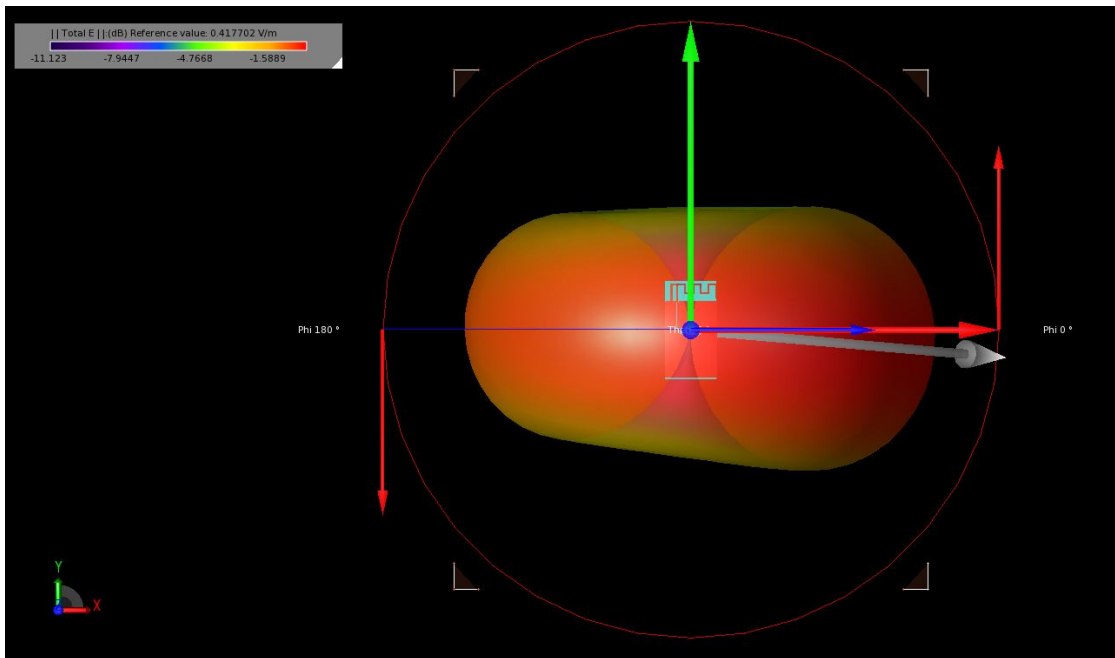

Figure 7: 3D radiation plot JN5168-001-M00 XY Orientation (simulation)

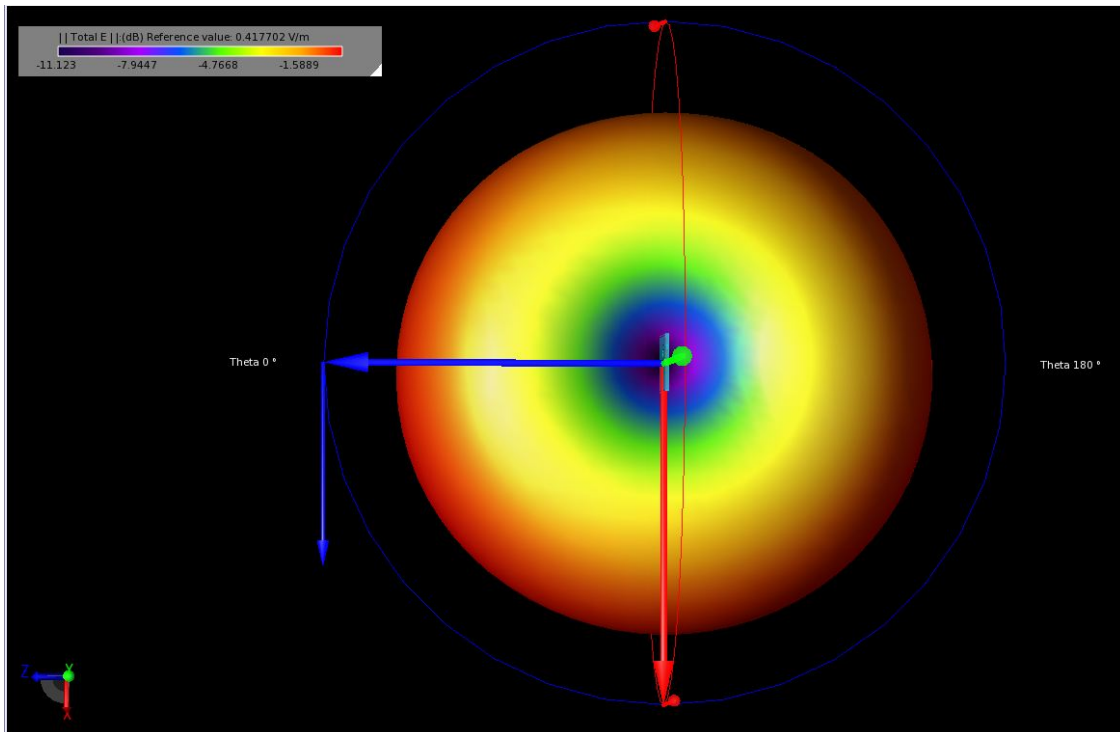

Figure 8: 3D radiation plot JN5168-001-M00 XZ Orientation (simulation)



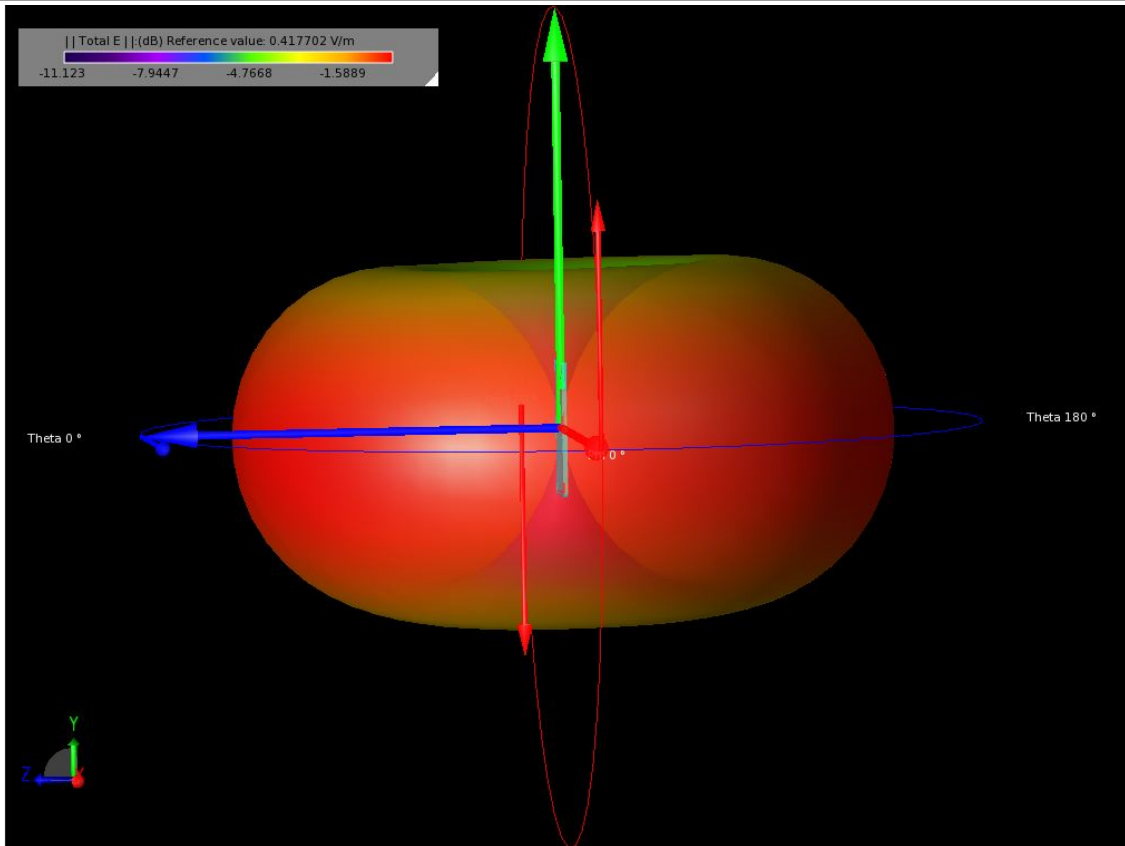
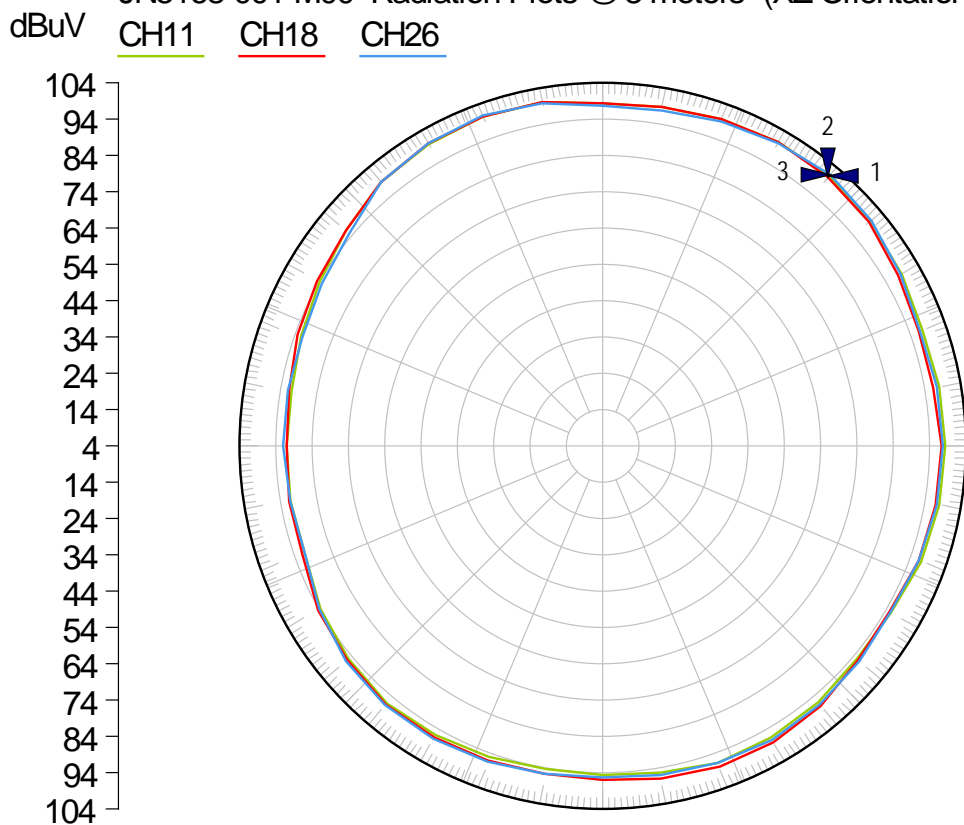

Figure 9: 3D radiation plot JN5168-001-M00 YZ Orientation (simulation)

JN5168-001-M00 Radiation Plots @ 3 meters (XZ Orientation)



Mkr	Trace	X-Axis	Value
1 ▼	CH11	40.0 deg	101.04 dBuV
2 ▼	CH18	40.0 deg	100.67 dBuV
3 ▼	CH26	40.0 deg	101.26 dBuV

Figure 10: Actual radiation plot of JN5168-001-M00 Mounted on a carrier PCB – XZ orientation

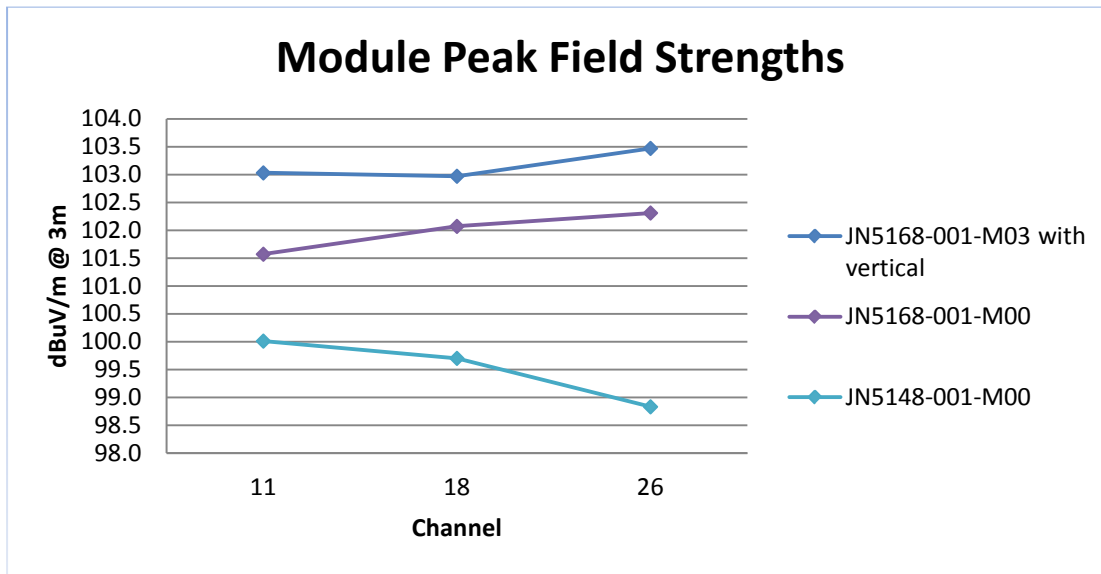
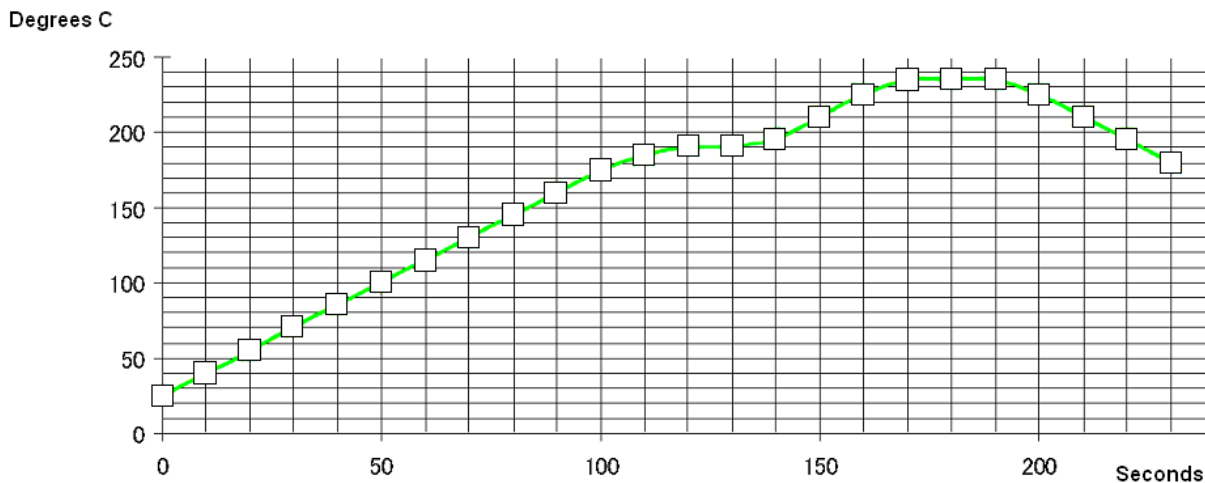

Figure 11: Peak Field Strengths for various modules optimised for height and azimuth

## A.5 Manufacturing

### A.5.1 Reflow Profile

For reflow soldering, it is recommended to follow the reflow profile in figure 6 as a guide, as well as the paste manufacturer's guidelines on peak flow temperature, soak times, time above liquid and ramp rates.



Temperature	25~160 °C	160~190 °C	> 220° C	230~Pk.	Pk. Temp (235°C)
Target Time (s)	90~130	30~60	20~50	10~15	150~270

Figure 12: Recommended solder reflow profile

## A.5.2 Soldering Paste and Cleaning

NXP does not recommend use of a solder paste that requires the module and PCB assembly to be cleaned (rinsed in water) for the following reasons:

Solder flux residues and water can be trapped by the PCB, can or components and result in short circuits.

The module label could be damaged or removed.

NXP recommends use of a 'no clean' solder paste for all its module products.

## A.6 Ordering Information

### Ordering Code Format:

**JN5168 - 001 – MYY**

#### Module Type (YY)

00	Standard Power, Integral antenna
03	Standard Power, uFI connector
05	Medium Power, uFL connector
06	High Power, uFI connector

Where this Data Sheet is denoted as “Advanced” or “Preliminary”, devices will be either Engineering Samples or Prototypes.

Part Number	Description
JN5168-001-M00	Shipped in tape mounted 500 piece reel
JN5168-001-M03	
JN5168-001-M05	
JN5168-001-M06	



Line	Content	Format	Options	Sample
1	NXP Logo	B&W outline logo		 <b>JN5168-001-M00</b> ZSDYWW NNNNN  FCC ID:TYOJN5168M0 IC:7438A-CYO5168M0
2	Part ID	JN5168-001-M0x	x is module type, 0, 3, 5 or 6	
3			Z SSMC	
			S APK	
			D RoHs Compliant	
			Y Year	
			WW Week	
3	Serial No.	NNNNN	Serial number from test	
5	FCC ID	FCCID:TYOJN5168Mx	x is module type 0,3,5 or 6	
6	IC ID	IC:7438A-CYO5168Mx	x is module type 0,3,5 or 6	

Figure 13: Example module labelling

---

## A.7 Related Documents

- [1] IEEE Std 802.15.4-2003 IEEE Standard for Information Technology – Part 15.4 Wireless Medium Access Control (MAC) and Physical Layer (PHY) Specifications for Low-Rate Wireless Personal Area Networks (LR-WPANs)
- [2] JN-DS-JN5168 Wireless Microcontroller Datasheet

## A.8 Federal Communication Commission Interference Statement

This equipment has been tested and found to comply with the limits for a Class B digital device, pursuant to Part 15 of the FCC Rules. These limits are designed to provide reasonable protection against harmful interference in a residential installation. This equipment generates, uses, and can radiate radio frequency energy and, if not installed and used in accordance with the instructions, may cause harmful interference to radio communications. However, there is no guarantee that interference will not occur in a particular installation. If this equipment does cause harmful interference to radio or television reception, which can be determined by turning the equipment off and on, the user is encouraged to try to correct the interference by one of the following measures:

- Reorient or relocate the receiving antenna.
- Increase the separation between the equipment and receiver.
- Connect the equipment into an outlet on a circuit different from that to which the receiver is connected.
- Consult the dealer or an experienced radio/TV technician for help.

This device complies with Part 15 of the FCC Rules. Operation is subject to the following two conditions: (1) This device may not cause harmful interference, and (2) this device must accept any interference received, including interference that may cause undesired operation.

FCC Caution: Any changes or modifications not expressly approved by the party responsible for compliance could void the user's authority to operate this equipment.

### **WARNING!**

#### **FCC Radiation Exposure Statement:**

This portable equipment with its antenna complies with FCC's RF radiation exposure limits set forth for an uncontrolled environment. To maintain compliance follow the instructions below;

1. This transmitter must not be co-located or operating in conjunction with any other antenna or transmitter.
2. Avoid direct contact to the antenna, or keep it to a minimum while using this equipment.

**This transmitter module is authorized to be used in other devices only by OEM integrators under the following condition:**

The transmitter module must not be co-located with any other antenna or transmitter.

As long as the above condition is met, further transmitter testing will not be required. However, the OEM integrator is still responsible for testing their end product for any additional compliance requirements required with this module installed (for example, digital device emissions, PC peripheral requirements, etc.).

This applies to the JN5168-001-M00, JN5168-001-M03 and JN5168-001-M05 devices, the JN5168-001-M06 is a mobile device (see section A.8.2)

## A.8.1 Antennas approved by FCC for use with JN5168 modules

	Brand	Model Number	Description	Gain (dBi)	Connector type
1	Antenna Factor	ANT-2.4-CW-RCT-RP	Vertical - knuckle antenna	2.2	RP-SMA
2	Antennova	2010B6090-01	Vertical - knuckle antenna	2.2	RP-SMA
3	Hyperlink Technology	HG2402RD-RSF	Vertical - knuckle antenna	2.2	RP-SMA
4	Aveslink Technology, Inc	E-0005-AC	Vertical- flying lead	2	RP-SMA
5	Aveslink Technology, Inc	E-2411-GC	Vertical - swivel	2	RP-SMA
6	Aveslink Technology, Inc	E-2410-CA	Vertical - bulkhead- flying lead	2	uFL
7	Aveslink Technology, Inc	E-2410-GC	Vertical - swivel	2	RP-SMA
8	Aveslink Technology, Inc	E-2820-CA	Vertical - bulkhead- flying lead	2	uFL
9	Aveslink Technology, Inc	E-2820-GC	Vertical - swivel	2	RP-SMA
10	Embedded Antenna Design	FBKR35068-RS-KR	Vertical - knuckle antenna	2	RP-SMA
11	Nearson	S131CL-L-PX-2450S	Vertical - knuckle-flying lead	2	uFL
12	Laird Technologies	WRR2400-IP04	Vertical - knuckle-flying lead	1.5	uFL
13	Laird Technologies	WRR2400-RPSMA	Vertical - knuckle-flying lead	1.3	RP-SMA
14	Aveslink Technology, Inc	E-6170-DA	Vertical - right angle	1	uFL
15	Laird Technologies	WCR2400-SMRP	Vertical - knuckle antenna	1	RP-SMA

This device has been designed to operate with the antennas listed above, and having a maximum gain of 2.2 dBi. Alternative vertical antennas may be used provided that the gain does not exceed 2.2 dBi. Antennas having a gain greater than 2.2 dBi are strictly prohibited for use with this device.

The required antenna impedance is 50 ohms.

## A.8.2 High Power Module usage limitation

The high power module variants are classified as 'mobile' device pursuant with FCC § 2.1091 and **must not** be used at a distance of < 20 cm (8") from any people. This applies to the JN5168-001-M06 module type (TYOJN5168M6).

**IMPORTANT NOTE:** In the event that these conditions cannot be met (for certain configurations or co-location with another transmitter), then the FCC authorization is no longer considered valid and the FCC ID can not be used on the final product. In these circumstances, the OEM integrator will be responsible for re-evaluating the end product (including the transmitter) and obtaining a separate FCC authorization.

The OEM integrator has to be aware not to provide information to the end user regarding how to install or remove this RF module in the user manual of the end product.

The user manual for the end product must include the following information in a prominent location;

"To comply with FCC's RF radiation exposure requirements, the antenna(s) used for this transmitter must not be co-located or operating in conjunction with any other antenna or transmitter."

## A.8.3 FCC End Product Labelling

The final 'end product' should be labelled in a visible area with the following:

"Contains TX FCC ID: TYOJN5168M0, TYOJN5168M3, TYOJN5168M5 or TYOJN5168M6" to reflect the version of the module being used inside the product.

## A.9 Industry Canada Statement

<p><i>This device complies with Industry Canada licence-exempt RSS standard(s). Operation is subject to the following two conditions: (1) this device may not cause interference, and (2) this device must accept any interference, including interference that may cause undesired operation of the device.</i></p>	<p><i>Le présent appareil est conforme aux CNR d'Industrie Canada applicables aux appareils radio exempts de licence. L'exploitation est autorisée aux deux conditions suivantes : (1) l'appareil ne doit pas produire de brouillage, et (2) l'utilisateur de l'appareil doit accepter tout brouillage radioélectrique subi, même si le brouillage est susceptible d'en compromettre le fonctionnement.</i></p>
--	---

To reduce potential radio interference to other users, the antenna type and its gain should be so chosen that the equivalent isotropic radiated power (e.i.r.p.) is not more than that permitted for successful communication.

These modules have been designed to operate with antennas having a maximum gain of 2.2 dBi. Antennas having a gain greater than 2.2 dBi are strictly prohibited for use with this device. The required antenna impedance is 50 ohms.

As long as the above condition is met, further transmitter testing will not be required. However, the OEM integrator is still responsible for testing their end-product for any additional compliance requirements required with this module installed (for example, digital device emissions, PC peripheral requirements, etc).

### A.9.1 Industry Canada End Product Labelling

For Industry Canada purposes the following should be used.

"Contains Industry Canada ID IC: 7438A-CYO5168M0, IC: 7438A-CYO5168M3, IC: 7438A-CYO5168M5 or IC: 7438A-CYO5168M6" to reflect the version of the module being used inside the product.

## A.10 European R & TTE Directive 1999/5/EC Statement

All modules listed in this datasheet with the exception of the JN5168-001-M06 are compliant with ETSI EN 300 328 V1.7.1 (2006-10), EMC, EN 301 489-17 v2.1.1 (2009-02) and the Basic Safety Assessment (BSA) EN 60950-1:2006 (2006-06) and are subject to a Notified Body Opinion.

The modules are approved for use with the antennas listed in the following table. The JN5168-001-M06 module is not approved for use in Europe, instead use the JN5168-001-M05 which produces the maximum permitted power.

Alternative vertical antennas may be used provided that the gain does not exceed 2.2 dBi.

	Brand	Model Number	Description	Gain (dBi)	Connector type
1	Antenna Factor	ANT-2.4-CW-RCT-SMA	Vertical - knuckle antenna	2.2	SMA
2	Antennova	B6090	Vertical - knuckle antenna	2.2	RP-SMA
3	Hyperlink Technology	HG2402RD-RSF	Vertical - knuckle antenna	2.2	RP-SMA
4	Aveslink Technology, Inc	E-0005-AC	Vertical- flying lead	2	RP-SMA
5	Aveslink Technology, Inc	E-2411-GC	Vertical - swivel	2	RP-SMA
6	Aveslink Technology, Inc	E-2410-CA	Vertical - bulkhead- flying lead	2	uFL
7	Aveslink Technology, Inc	E-2410-GC	Vertical - swivel	2	RP-SMA
8	Aveslink Technology, Inc	E-2820-CA	Vertical - bulkhead- flying lead	2	uFL
9	Aveslink Technology, Inc	E-2820-GC	Vertical - swivel	2	RP-SMA
10	Embedded Antenna Design	FBKR35068-RS-KR	Vertical - knuckle antenna	2	RP-SMA
11	Nearson	S131CL-L-PX-2450S	Vertical - knuckle-flying lead	2	uFL
12	Laird Technologies	WRR2400-IP04	Vertical - knuckle-flying lead	1.5	uFL
13	Laird Technologies	WRR2400-RPSMA	Vertical - knuckle-flying lead	1.3	RP-SMA
14	Aveslink Technology, Inc	E-6170-DA	Vertical - right angle	1	uFL
15	Laird Technologies	WCR2400-SMRP	Vertical - knuckle antenna	1	RP-SMA

---

## A.11 RoHS Compliance

JN5168-001-My devices meet the requirements of Directive 2002/95/EC of the European Parliament and of the Council on the Restriction of Hazardous Substance (RoHS).

The JN5168-001-M00, M03, M05 and M06 modules meet the requirements of Chinese RoHS requirements SJ/T11363-2006.

Full data can be found at [www.nxp.com/jennic](http://www.nxp.com/jennic).

## A.12 Status Information

The status of this Data Sheet is **Preliminary**.

NXP products progress according to the following format:

### Advanced

The Data Sheet shows the specification of a product in planning or in development.

The functionality and electrical performance specifications are target values and may be used as a guide to the final specification.

NXP reserves the right to make changes to the product specification at anytime without notice.

### Preliminary

The Data Sheet shows the specification of a product that is commercially available, but is not yet fully qualified.

The functionality of the product is final. The electrical performance specifications are target values and may be used as a guide to the final specification. NXP reserves the right to make changes to the product specification at anytime without notice.

### Production

This is the production Data Sheet for the product.

All functional and electrical performance specifications, where included, including min and max values are derived from detailed product characterization.

This Data Sheet supersedes all previous document versions.

NXP reserves the right to make changes to the product specification at anytime.

## A.13 Disclaimers

The contents of this document are subject to change without notice. NXP reserves the right to make changes, without notice, in the products, including circuits and/or software, described or contained therein. Information contained in this document regarding device applications and the like is intended through suggestion only and may be superseded by updates. It is your responsibility to ensure that your application meets with your specifications.

NXP warrants performance of its hardware products to the specifications applicable at the time of sale in accordance with NXP's standard warranty. Testing and other quality control techniques are used to the extent NXP deems necessary to support this warranty. Except where mandatory by government requirements, testing of all parameters of each product is not necessarily performed.

NXP assumes no responsibility or liability for the use of any of these products, conveys no license or title under any patent, copyright, or mask work right to these products, and makes no representations or warranties that these products are free from patent, copyright, or mask work infringement, unless otherwise specified.

NXP products are not intended for use in life support systems, appliances or systems where malfunction of these products can reasonably be expected to result in personal injury, death or severe property or environmental damage. NXP customers using or selling these products for use in such applications do so at their own risk and agree to fully indemnify NXP for any damages resulting from such use.

All products are sold subject to NXP's terms and conditions of sale supplied at the time of order acknowledgment.

All trademarks are the property of their respective owners.



---

## Version Control

Version	Notes
1.0	Initial release
1.1	Additional clarification of RF exposure conditions added to FCC Section A8 and minor corrections made
1.2	Revision of key parameters. Module footprint dimension updated

**NXP Laboratories UK Ltd**  
Furnival Street  
Sheffield  
S1 4QT  
United Kingdom

Tel: +44 (0)114 281 2655  
Fax: +44 (0) 114 281 2951

For the contact details of your local NXP office or distributor, refer to the NXP web site:

[www.nxp.com/jennic](http://www.nxp.com/jennic)