

- △ NOTES:
- Rating: ~~60V~~ 8A
PITCH: 3.81 mm
 - Insulation Withstands Voltage:
AC 1000V/MIN
 - Insulation Resistance:
1000MΩ or more at DC500V
 - Using Temperature Range:
△ ~~-40°C~+130°C~~
-40°C~+120°C
 - Screw Torque Value: 2kgf-cm(MAX)
 - Suitable Electric Wire: AWG 22~16
 - Undimensioned Tolerances:

—	∩	∇	0.05/10
⊥	//	≡	0.2/10
PITCH ERROR			0.05/10
UNDIMENSIONS TOLERANCES			±0.3

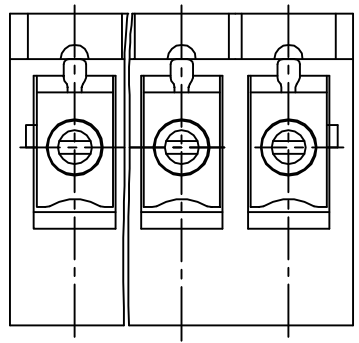
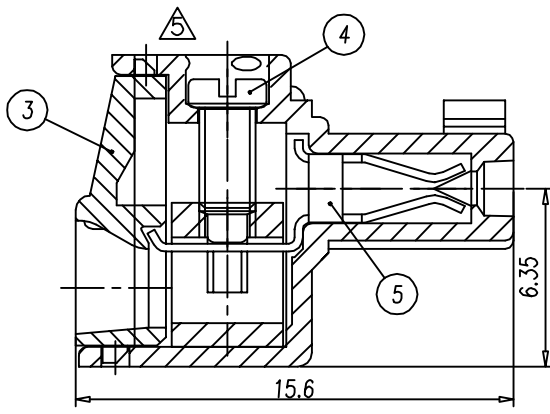
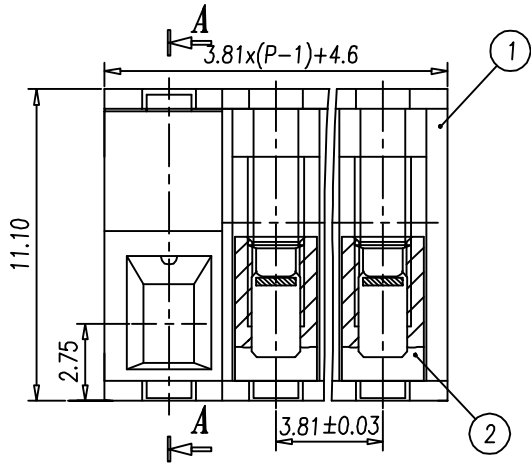

5	CLAMP	0070B00100	P	BRONZE	
4	SCREW1	S000010200	P	STEEL	M2/Zn Plated
3	END COVER	0070L00000	1	PBT	GREEN
2	WIRE CAGE △	X000007400 X000002700	P	HARD BRASS	△ M2/Ni Plated M2/Tin Plated
1	HOUSING	0070A00000	1	PBT	GREEN

△		TXK	04.02.13	ITEM	NAME OF PART	NO. OF PART	Q'TY	MATERIAL	NOTES
△		YFY	03.10.09	DWG.		DATE	99,02,28	UNITS	MM SHEET/OF 1/1
△		YFY	03.06.13	CHK.		DATE		SCALE	5:1 (:) ⊕ ⊞
△		YAO	01,10,22	APP.		DATE		NAME	21.1550M/XX
△		XJIANG	01.01.04					DWG NO.	
REV.	CONTENT	CHK.	DATE	IMO					