

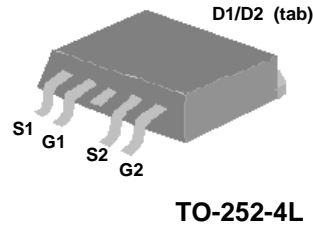

## Complementary N and P-channel Enhancement-mode Power MOSFETs

- Simple Drive Requirement
- Good Thermal Performance
- Fast Switching Performance
- RoHS-compliant, Halogen-free



N-CH	$BV_{DSS}$	60V
	$R_{DS(ON)}$	72m $\Omega$
	$I_D$	9A
P-CH	$BV_{DSS}$	-60V
	$R_{DS(ON)}$	125m $\Omega$
	$I_D$	-6A

### Description

Advanced Power MOSFETs from APEC provide the designer with the best combination of fast switching, low on-resistance and cost-effectiveness.

The AP4578GH-HF-3 is in a standard TO-252 package, which is widely used for commercial and industrial surface-mount applications, and is well suited for applications such as DC and servo motor drives.

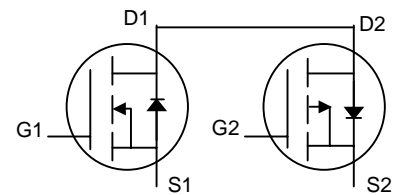

### Absolute Maximum Ratings

Symbol	Parameter	Rating		Units
		N-channel	P-channel	
$V_{DS}$	Drain-Source Voltage	60	-60	V
$V_{GS}$	Gate-Source Voltage	$\pm 25$	$\pm 25$	V
$I_D$ at $T_A=25^\circ\text{C}$	Continuous Drain Current <sup>3</sup>	9	-6	A
$I_D$ at $T_A=70^\circ\text{C}$	Continuous Drain Current <sup>3</sup>	6	-4	A
$I_{DM}$	Pulsed Drain Current <sup>1</sup>	30	-30	A
$P_D$ at $T_A=25^\circ\text{C}$	Total Power Dissipation	8.9		W
$T_{STG}$	Storage Temperature Range	-55 to 150		$^\circ\text{C}$
$T_J$	Operating Junction Temperature Range	-55 to 150		$^\circ\text{C}$

### Thermal Data

Symbol	Parameter	Value	Unit
Rthj-c	Maximum Thermal Resistance, Junction-case <sup>3</sup>	14	$^\circ\text{C/W}$
Rthj-a	Maximum Thermal Resistance, Junction-ambient <sup>3</sup>	110	$^\circ\text{C/W}$

### Ordering Information

AP4578GH-HF-3TR : in RoHS-compliant, halogen-free TO-252-4L, shipped on tape and reel (3000 pcs/reel)



**N-channel Electrical Specifications at  $T_j=25^\circ\text{C}$  (unless otherwise specified)**

Symbol	Parameter	Test Conditions	Min.	Typ.	Max.	Units
$BV_{DSS}$	Drain-Source Breakdown Voltage	$V_{GS}=0V, I_D=250\mu A$	60	-	-	V
$\Delta BV_{DSS}/\Delta T_j$	Breakdown Voltage Temperature Coefficient	Reference to $25^\circ\text{C}, I_D=1\text{mA}$	-	0.05	-	$V/^\circ\text{C}$
$R_{DS(ON)}$	Static Drain-Source On-Resistance <sup>2</sup>	$V_{GS}=10V, I_D=5A$	-	-	72	$m\Omega$
		$V_{GS}=4.5V, I_D=3A$	-	-	90	$m\Omega$
$V_{GS(th)}$	Gate Threshold Voltage	$V_{DS}=V_{GS}, I_D=250\mu A$	1	-	3	V
$g_{fs}$	Forward Transconductance	$V_{DS}=10V, I_D=5A$	-	8	-	S
$I_{DSS}$	Drain-Source Leakage Current	$V_{DS}=60V, V_{GS}=0V$	-	-	10	$\mu A$
	Drain-Source Leakage Current ( $T_j=125^\circ\text{C}$ )	$V_{DS}=48V, V_{GS}=0V$	-	-	250	$\mu A$
$I_{GSS}$	Gate-Source Leakage	$V_{GS}=\pm 25V, V_{DS}=0V$	-	-	$\pm 100$	nA
$Q_g$	Total Gate Charge <sup>2</sup>	$I_D=5A$	-	9	15	nC
$Q_{gs}$	Gate-Source Charge	$V_{DS}=48V$	-	2	-	nC
$Q_{gd}$	Gate-Drain ("Miller") Charge	$V_{GS}=4.5V$	-	5	-	nC
$t_{d(on)}$	Turn-on Delay Time <sup>2</sup>	$V_{DS}=30V$	-	7	-	ns
$t_r$	Rise Time	$I_D=1A$	-	5	-	ns
$t_{d(off)}$	Turn-off Delay Time	$R_G=3.3\Omega$	-	21	-	ns
$t_f$	Fall Time	$V_{GS}=10V$	-	5	-	ns
$C_{iss}$	Input Capacitance	$V_{GS}=0V$	-	750	1200	pF
$C_{oss}$	Output Capacitance	$V_{DS}=25V$	-	80	-	pF
$C_{rss}$	Reverse Transfer Capacitance	$f=1.0\text{MHz}$	-	60	-	pF
$R_g$	Gate Resistance	$f=1.0\text{MHz}$	-	1.5	2.3	$\Omega$

**Source-Drain Diode**

Symbol	Parameter	Test Conditions	Min.	Typ.	Max.	Units
$V_{SD}$	Forward On Voltage <sup>2</sup>	$I_S=5A, V_{GS}=0V$	-	-	1.2	V
$t_{rr}$	Reverse Recovery Time <sup>2</sup>	$I_S=5A, V_{GS}=0V$	-	33	-	ns
$Q_{rr}$	Reverse Recovery Charge	$di/dt=100A/\mu s$	-	55	-	nC

**Notes:**

1. Pulse width limited by maximum junction temperature.
2. Pulse width  $\leq 300\mu s$ , duty cycle  $\leq 2\%$ .

THIS PRODUCT IS SENSITIVE TO ELECTROSTATIC DISCHARGE, PLEASE HANDLE WITH CAUTION.

USE OF THIS PRODUCT AS A CRITICAL COMPONENT IN LIFE SUPPORT OR OTHER SIMILAR SYSTEMS IS NOT AUTHORIZED.

APEC DOES NOT ASSUME ANY LIABILITY ARISING OUT OF THE APPLICATION OR USE OF ANY PRODUCT OR CIRCUIT DESCRIBED HEREIN; NEITHER DOES IT CONVEY ANY LICENSE UNDER ITS PATENT RIGHTS, NOR THE RIGHTS OF OTHERS.

APEC RESERVES THE RIGHT TO MAKE CHANGES WITHOUT FURTHER NOTICE TO ANY PRODUCTS HEREIN TO IMPROVE RELIABILITY, FUNCTION OR DESIGN.



**P-channel Electrical Specifications at  $T_j=25^\circ\text{C}$  (unless otherwise specified)**

Symbol	Parameter	Test Conditions	Min.	Typ.	Max.	Units
$BV_{DSS}$	Drain-Source Breakdown Voltage	$V_{GS}=0V, I_D=-250\mu A$	-60	-	-	V
$\Delta BV_{DSS}/\Delta T_j$	Breakdown Voltage Temperature Coefficient	Reference to $25^\circ\text{C}$ , $I_D=-1\text{mA}$	-	-0.04	-	V/ $^\circ\text{C}$
$R_{DS(ON)}$	Static Drain-Source On-Resistance <sup>2</sup>	$V_{GS}=-10V, I_D=-3A$	-	-	125	m $\Omega$
		$V_{GS}=-4.5V, I_D=-2A$	-	-	150	m $\Omega$
$V_{GS(th)}$	Gate Threshold Voltage	$V_{DS}=V_{GS}, I_D=-250\mu A$	-1	-	-3	V
$g_{fs}$	Forward Transconductance	$V_{DS}=-10V, I_D=-3A$	-	5	-	S
$I_{DSS}$	Drain-Source Leakage Current	$V_{DS}=-60V, V_{GS}=0V$	-	-	-10	$\mu A$
	Drain-Source Leakage Current ( $T_j=125^\circ\text{C}$ )	$V_{DS}=-48V, V_{GS}=0V$	-	-	-250	$\mu A$
$I_{GSS}$	Gate-Source Leakage	$V_{GS}=\pm 25V, V_{DS}=0V$	-	-	$\pm 100$	nA
$Q_g$	Total Gate Charge <sup>2</sup>	$I_D=-3A$	-	13	21	nC
$Q_{gs}$	Gate-Source Charge	$V_{DS}=-48V$	-	3	-	nC
$Q_{gd}$	Gate-Drain ("Miller") Charge	$V_{GS}=-4.5V$	-	6	-	nC
$t_{d(on)}$	Turn-on Delay Time <sup>2</sup>	$V_{DS}=-30V$	-	11	-	ns
$t_r$	Rise Time	$I_D=-1A$	-	5	-	ns
$t_{d(off)}$	Turn-off Delay Time	$R_G=3.3\Omega, V_{GS}=-10V$	-	35	-	ns
$t_f$	Fall Time	$R_D=30\Omega$	-	7	-	ns
$C_{iss}$	Input Capacitance	$V_{GS}=0V$	-	1030	1650	pF
$C_{oss}$	Output Capacitance	$V_{DS}=-25V$	-	90	-	pF
$C_{rss}$	Reverse Transfer Capacitance	$f=1.0\text{MHz}$	-	75	-	pF
$R_g$	Gate Resistance	$f=1.0\text{MHz}$	-	5	7.5	$\Omega$

**Source-Drain Diode**

Symbol	Parameter	Test Conditions	Min.	Typ.	Max.	Units
$V_{SD}$	Forward On Voltage <sup>2</sup>	$I_S=-3A, V_{GS}=0V$	-	-	-1.2	V
$t_{rr}$	Reverse Recovery Time <sup>2</sup>	$I_S=-3A, V_{GS}=0V$	-	42	-	ns
$Q_{rr}$	Reverse Recovery Charge	$dI/dt=-100A/\mu s$	-	82	-	nC

**Notes:**

1. Pulse width limited by maximum junction temperature.
2. Pulse width  $\leq 300\mu s$ , duty cycle  $\leq 2\%$ .

THIS PRODUCT IS SENSITIVE TO ELECTROSTATIC DISCHARGE, PLEASE HANDLE WITH CAUTION.

USE OF THIS PRODUCT AS A CRITICAL COMPONENT IN LIFE SUPPORT OR OTHER SIMILAR SYSTEMS IS NOT AUTHORIZED.

APEC DOES NOT ASSUME ANY LIABILITY ARISING OUT OF THE APPLICATION OR USE OF ANY PRODUCT OR CIRCUIT DESCRIBED HEREIN; NEITHER DOES IT CONVEY ANY LICENSE UNDER ITS PATENT RIGHTS, NOR THE RIGHTS OF OTHERS.

APEC RESERVES THE RIGHT TO MAKE CHANGES WITHOUT FURTHER NOTICE TO ANY PRODUCTS HEREIN TO IMPROVE RELIABILITY, FUNCTION OR DESIGN.



Typical N-channel Electrical Characteristics

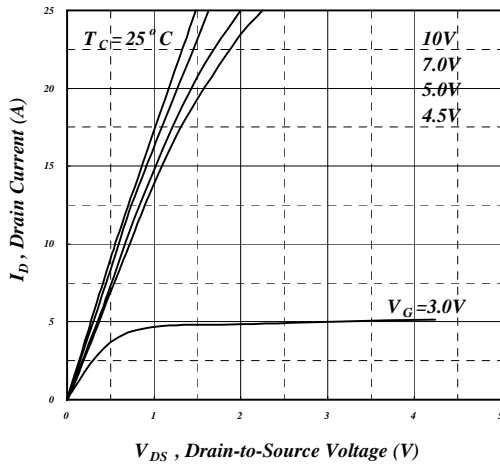

Fig 1. Typical Output Characteristics

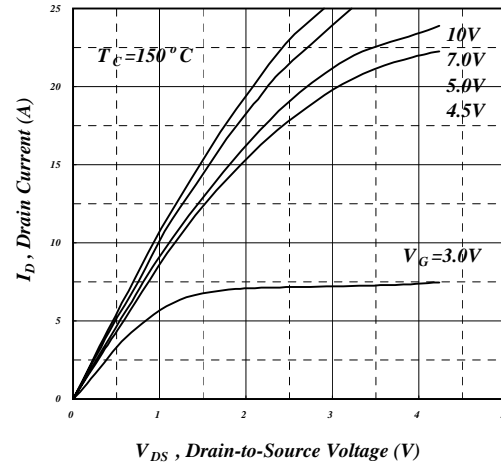

Fig 2. Typical Output Characteristics

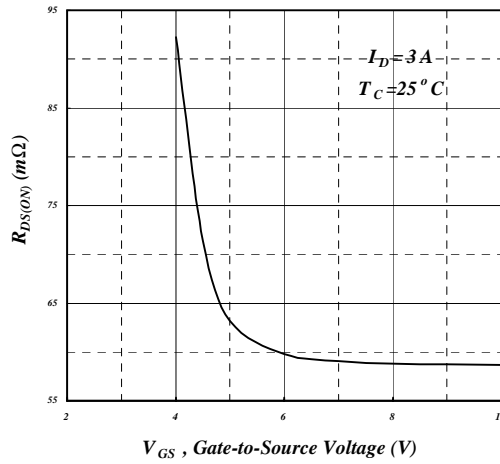

Fig 3. On-Resistance vs. Gate Voltage

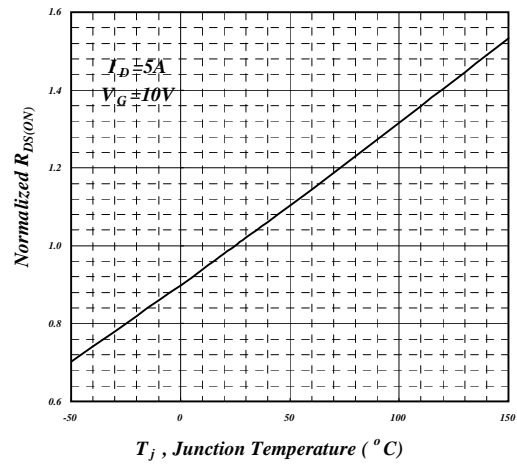

Fig 4. Normalized On-Resistance vs. Junction Temperature

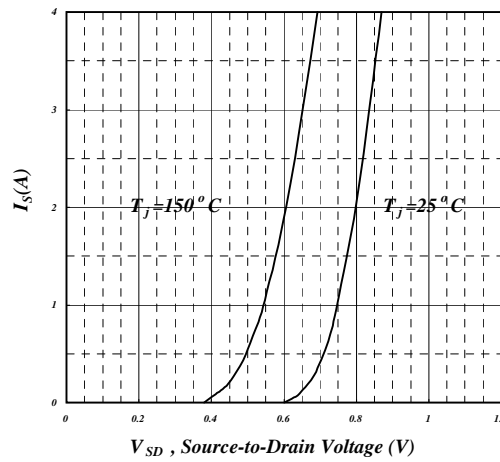

Fig 5. Forward Characteristic of Reverse Diode

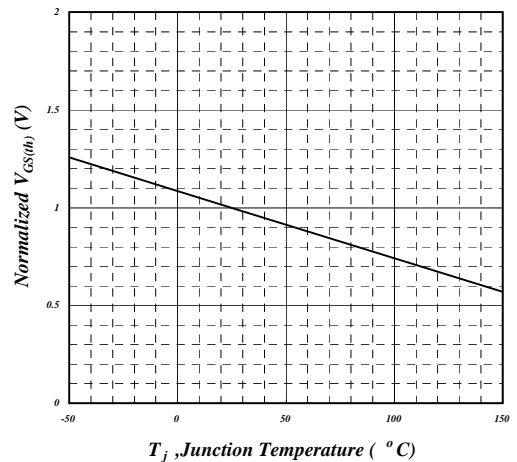

Fig 6. Gate Threshold Voltage vs. Junction Temperature



Typical N-channel Electrical Characteristics (cont.)

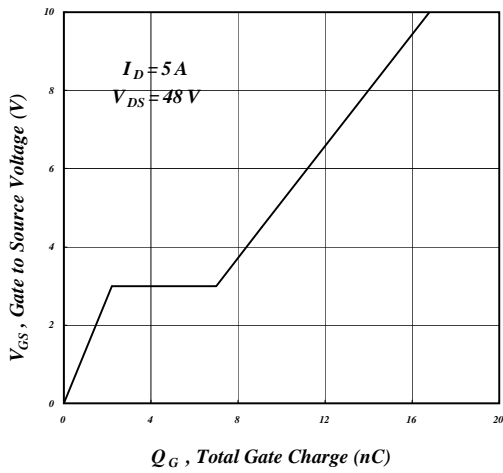

Fig 7. Gate Charge Characteristics

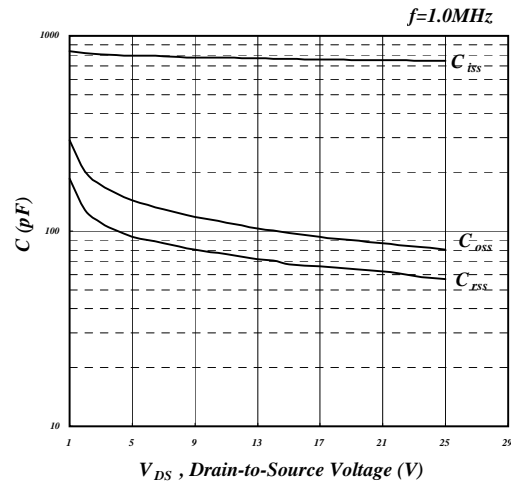

Fig 8. Typical Capacitance Characteristics

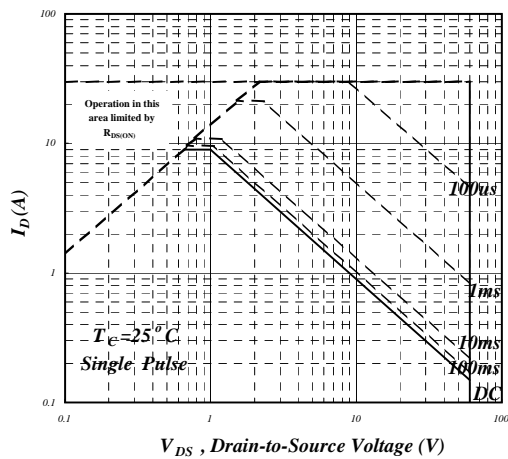

Fig 9. Maximum Safe Operating Area

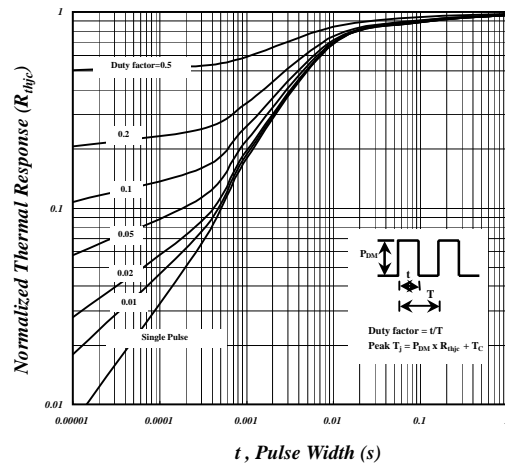

Fig 10. Effective Transient Thermal Impedance

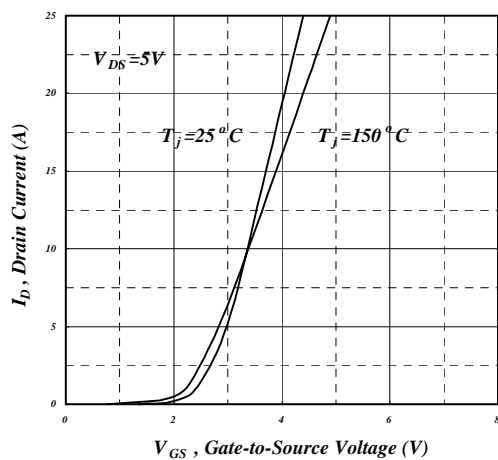

Fig 11. Transfer Characteristics

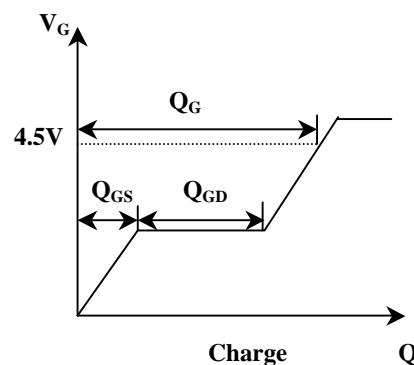

Fig 12. Gate Charge Waveform



Typical P-channel Electrical Characteristics

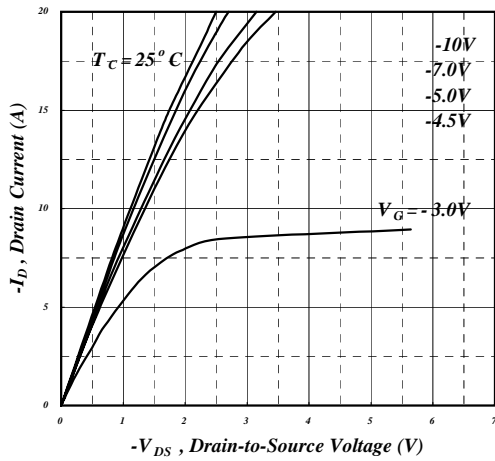

Fig 1. Typical Output Characteristics

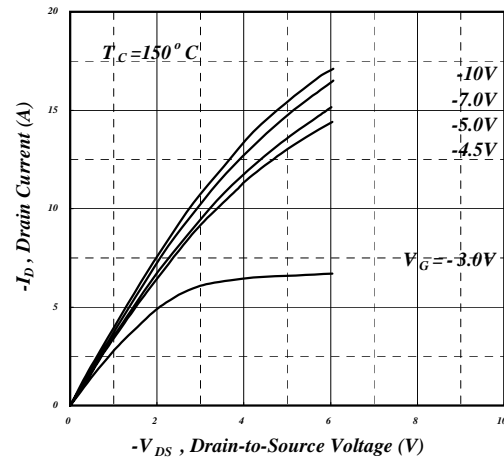

Fig 2. Typical Output Characteristics

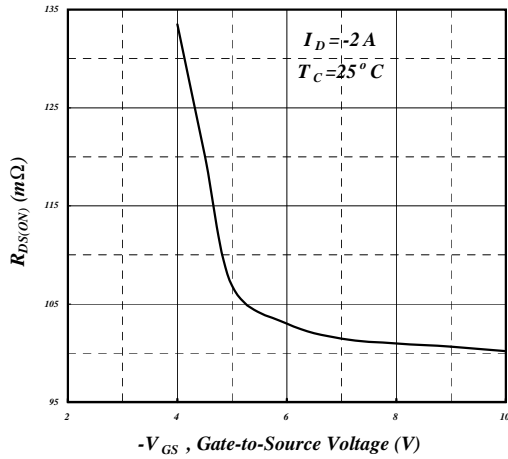

Fig 3. On-Resistance vs. Gate Voltage

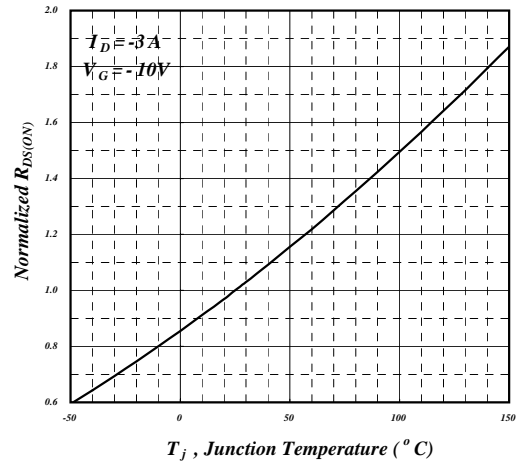

Fig 4. Normalized On-Resistance vs. Junction Temperature

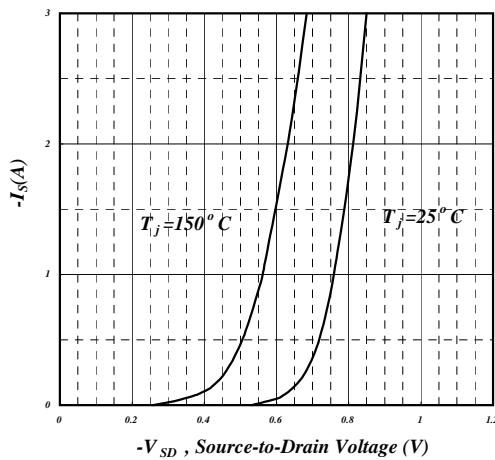

Fig 5. Forward Characteristic of Reverse Diode

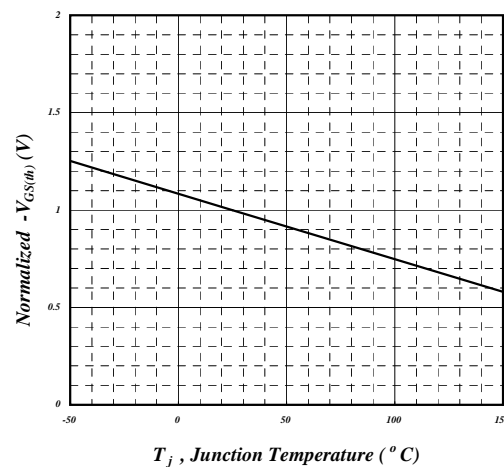

Fig 6. Gate Threshold Voltage vs. Junction Temperature



Typical P-channel Electrical Characteristics (cont.)

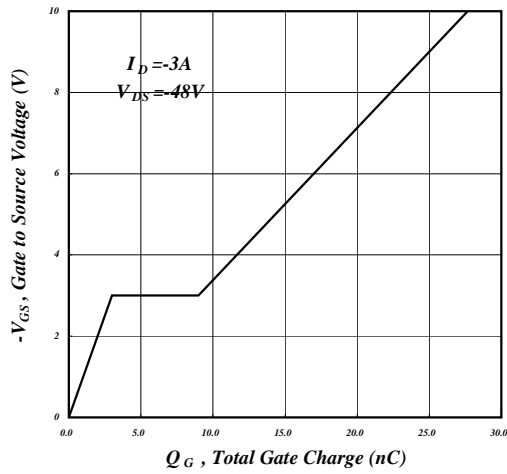

Fig 7. Gate Charge Characteristics

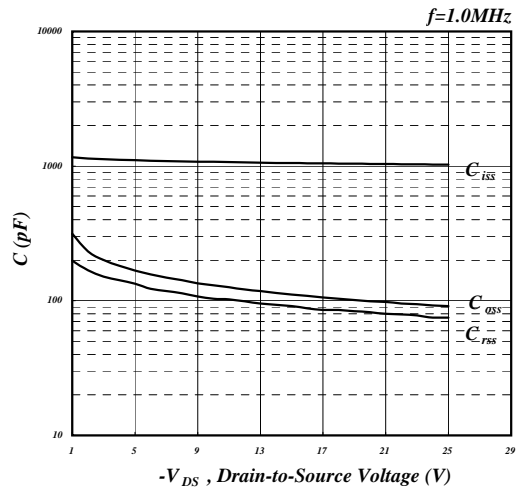

Fig 8. Typical Capacitance Characteristics

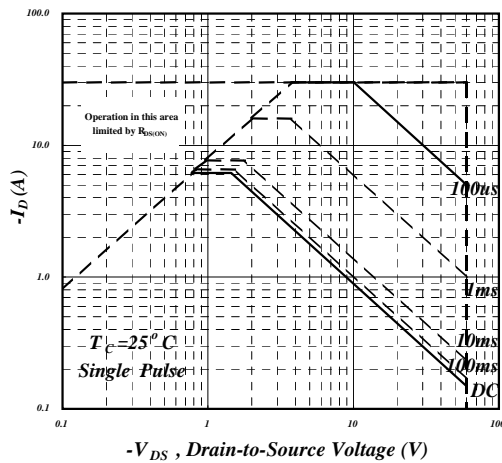

Fig 9. Maximum Safe Operating Area

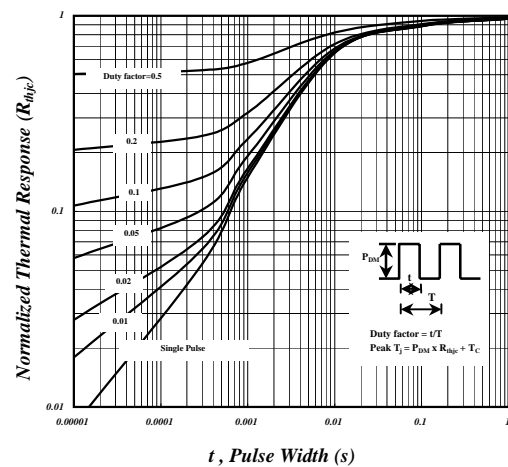

Fig 10. Effective Transient Thermal Impedance

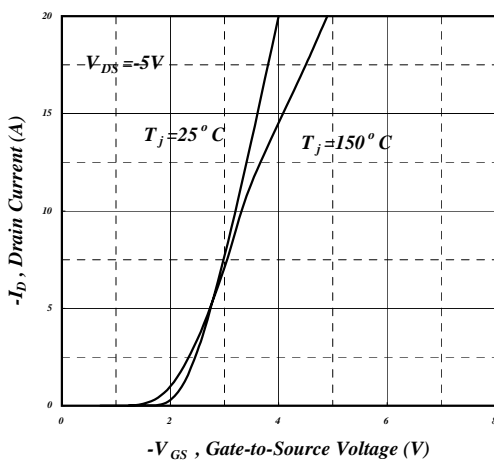

Fig 11. Transfer Characteristics

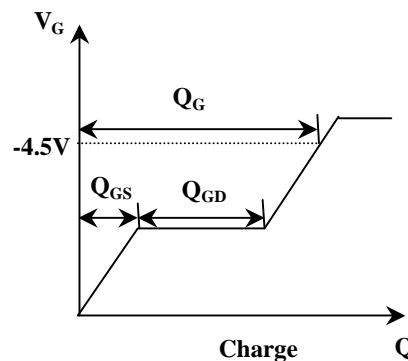
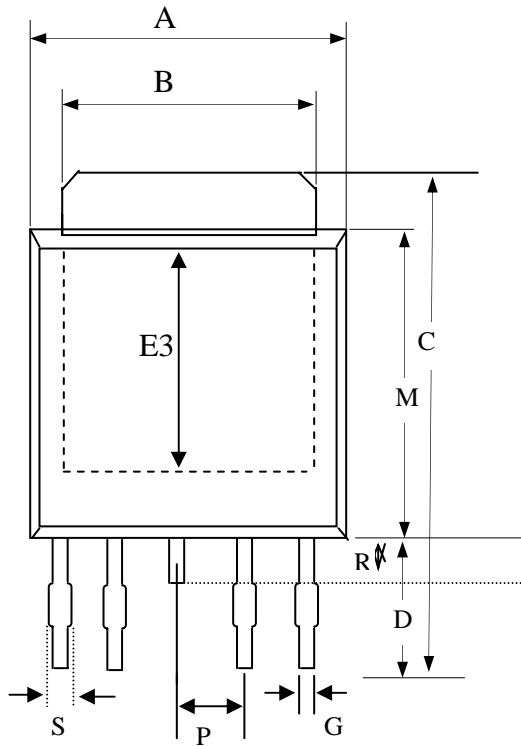

Fig 12. Gate Charge Waveform



**Package Dimensions: TO-252-4L**



SYMBOLS	Millimeters		
	MIN	NOM	MAX
A	6.40	6.6	6.80
B	5.2	5.35	5.50
C	9.40	9.80	10.20
D	2.40	2.70	3.00
P	1.27 REF.		
S	0.50	0.65	0.80
E3	3.50	4.00	4.50
R	0.80	1.00	1.20
G	0.40	0.50	0.60
H	2.20	2.30	2.40
J	0.45	0.50	0.55
K	0.00	0.075	0.15
L	0.90	1.20	1.50
M	5.40	5.60	5.80

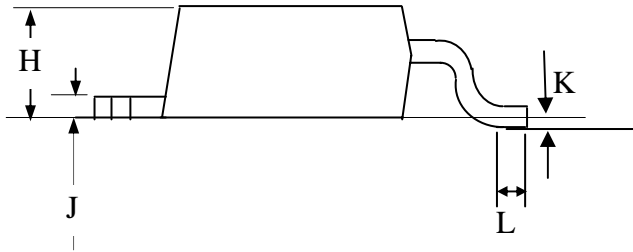

1. All dimensions are in millimeters.
2. Dimensions do not include mold protrusions.

**Marking Information:**

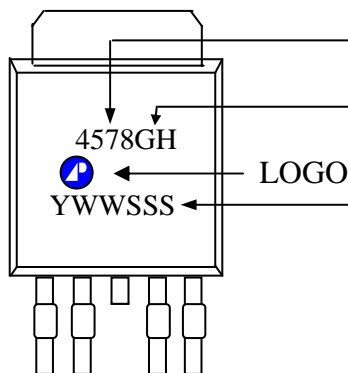

Product: AP4578

Package:

GH = RoHS-compliant halogen-free TO-252-4L

Date/lot code (YWWSSS)

Y: Last digit of the year

WW: Work week

SSS: Lot code sequence