

## Wireless M-Bus Module – High Performance

868 MHz SRD Band

### Key Features

- Low-cost Wireless M-Bus radio module (868 MHz SRD Band)
- Embedded Wireless M-Bus according to EN13757-4:2005 standard
- Small form factor: 17 x 27 x 4 mm
- Optimized for battery use
- Easy switching between operating modes S1, S1m, S2, T1, T2, R2
- Communication and configuration via UART/SPI Interface
- Supports AES128 data encryption
- Conforms with EU R&TTE 1999/5/EC directive
- Available on Tape & Reel for SMT assembly
- Also available as wireless USB adapter (AMB8665-M)
- Compatible to AMB8426-M, enhanced radio chipset radio and microprocessor<sup>1</sup>

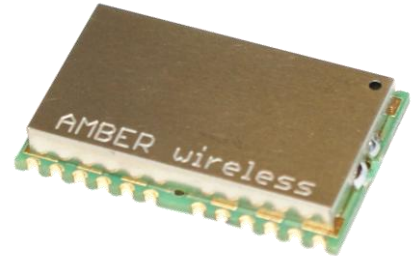

### Description

The wireless M-Bus standard EN13757-4:2005 specifies the communication between water, gas, heat and electricity meters and concentrators. The standard comprises various operating modes (S, T and R) to meet the requirements of one-way and two-way data communication in stationary and mobile systems.

The AMB8626-M is an all embedded low-cost wireless M-Bus radio module operating in the 868 MHz frequency band. The integrated protocol controls the entire data communication. Data packets are built and transmitted according to wireless M-Bus standard. Configuration of parameters is handled via the UART interface. The module automatically adds the Manufacturer ID and the Address based on parameters configured in the radio module. Measured field strength (RSSI value) offers the option of enhancing quality of the radio link.

The customised application layer can be fully integrated in the radio module, thus eliminating the need for an external host microcontroller. The radio module supports the AES-128 encryption standard. A very low-power mode ensures long battery lifetime.

The module is pre-certified for operation under the European radio regulations for license-free use.

The AMB8426-M is a surface-mount device and is available on Tape & Reel for volume production.

### Interfaces

The AMB8626-M is connected to a host system via an UART interface with data rates of up to 115.2 kbps. Alternatively, a SPI interface is offered (in preparation).

When using appropriate firmware, the module is also suitable for autonomously recording digital or analogue signals. Other pins can be used for data flow control and to switch between operating modes.

### Range of Applications

The radio module is designed for automatic meter reading applications for wireless data transmission according to the Wireless M-Bus standard. The radio module is designed to be integrated in meters, concentrators and mobile metering devices. Other applications are conceivable. Its compact dimensions and low-power consumption make the radio module ideal for battery-powered devices.

<sup>1</sup> Migration guide available upon request

**Dimensions**

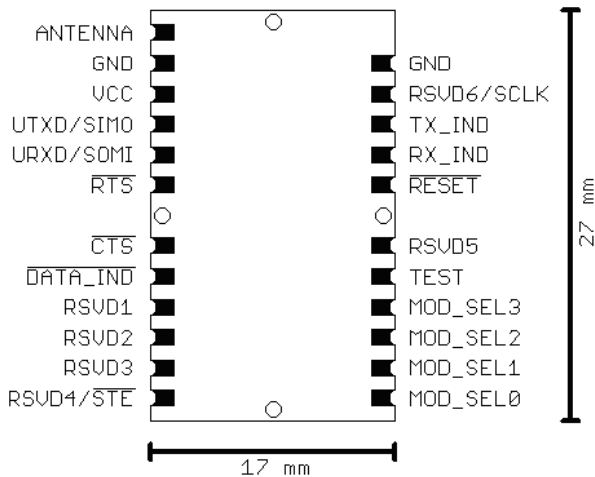

**Pin Assignment**

Pad Name	Description
ANTENNA	Antenna port
GND	Ground
VCC	Positive supply voltage
UTXD, URXD	UART transmit, UART receive
SIMO	Slave In Master Out (SPI in preparation)
SOMI	Slave Out Master In (SPI in preparation)
SCLK	SPI clock (SPI in preparation)
/STE	Slave Transmit Enable (SPI in preparation)
/RESET	Reset signal
TX_IND	Signals radio transmission
RX_IND	Signals radio reception
MOD_SELx	wM-Bus mode preselect
/RTS, /CTS	Hardware handshake
/DATA_IND	Signals incoming data
RSVDx	Reserved for future use
TEST	Used for programming purposes

**Specifications**

TA = 25°C, VCC = 3.3 V if nothing else stated

Performance	Range*	Up to 2000 m
	RF data rate	2.4 / 16.384 / 66.6 kbps (according to EN 13757-4:2005)
	Interface data rate	Up to 115.2 kbps (UART)
	Output power	14 dBm (50 Ω)
	RF sensitivity	Down to -109 / -105 / -101 dBm (50 Ω)
General	Power supply voltage	2.0 – 3.6 V
	Power consumption	- TX: typ. 53 mA - RX: typ. 30 mA - Low Power: typ. 3 µA
	Dimensions	17 x 27 x 4 mm
	Operating temperature	-30 to +85 °C
	Weight	Approx. 3 g
	Antenna	External antenna port (50 Ω)
RF technology	Frequency range	868.03 - 868.95 MHz
	Channel spacing	868.03 MHz + k • 0.06 MHz k=[0,9] 868.30 MHz 868.95 MHz
	Modulation	2-FSK
Conformity	Europe	EN 300220, EN 301489, EN 60950, EN 50371

\* Range stated assumes line-of-sight. Actual range may vary depending on antenna choice, board integration and environment.

**Related Products**

- **AMB3626-M** Radio Module 169 MHz (wireless M-Bus Mode N)
- **AMB8426-M** Wireless M-Bus Module 868 MHz (Low Power)

**Ordering information**

Item no.	Description
AMB8626-M	Radio Module 868 MHz
AMB8626-M-TR	Radio Module 868 MHz, Tape & Reel

**Contact**

AMBER wireless GmbH  
 Albin-Koebis-Strasse 18  
 51147 Cologne, Germany  
 Tel. +49 2203 98019 0  
 Fax +49 2203 98019 25  
 E-mail: [info@amber-wireless.de](mailto:info@amber-wireless.de)  
 Internet: [www.amber-wireless.de](http://www.amber-wireless.de)