

# TAS5558

## 8-Channel HD Compatible Audio Processor with ASRC and PWM Output

### Data Manual



PRODUCTION DATA information is current as of publication date. Products conform to specifications per the terms of the Texas Instruments standard warranty. Production processing does not necessarily include testing of all parameters.

Literature Number: SLES273A  
April 2013–Revised June 2013

## 8-Channel HD Compatible Audio Processor with ASRC and PWM Output

Check for Samples: [TAS5558](#)

### 1 Introduction

#### 1.1 Features

- **General Features**
  - 8ch Asynchronous Sample Rate Converter
  - 8 Channel Audio Processing for 32-192 kHz (ARSC to 96kHz)
  - 4 Channel Native Audio Processing at 192kHz
  - 30 kHz Audio Bandwidth for DTS-HD Compatibility
  - Energy Manager for Overall System Power Control
  - Power Supply Volume Control
- **Audio Input or Output**
  - Up to Five Synchronous Serial Audio Inputs (10 Channels)
  - Up to One Synchronous Serial Audio Outputs (2 Channels)
  - Trimmed Internal Oscillator for Clock Auto Detection and Limp Mode
  - Slave Mode 32-192KHz With Auto/Manual Sample Rate Detection
  - Eight Differential PWM Output That can Support AD or BD Modulation
  - Two Differential PWM Headphone Outputs
  - I2S Out for External Wireless Sub
  - PWM Output Supports Single Ended (S.E.) or Bridge Tied Load (BTL)
- **Audio Processing**
  - Volume Control Range 18 dB to –127 dB (Master and Eight Channel Volume)
  - Bass and Treble Tone Controls With  $\pm 18$ -dB Range, Selectable Corner Frequencies
  - Configurable Loudness Compensation
  - Two Dynamic Range Compressors With Two Thresholds, Two Offsets, and Three Slopes
  - Seven Biquads Per Channel
  - Coefficient Banking and Auto Bank Switch
- **PWM Processing**
  - >105-dB Dynamic Range
  - THD+N < 0.1% (0–40 kHz)
  - 20-Hz–40-kHz, Flat Noise Floor for 32KHz - 192KHz
  - Flexible Automute Logic With Programmable Threshold and Duration for Noise-Free Operation
  - Power-Supply Volume Control (PSVC) in High-Performance Applications
  - Adjustable Modulation Limit

#### 1.2 APPLICATIONS

- **Interface Seamlessly with Most Digital Audio Decoders**

#### 1.3 DESCRIPTION

The TAS5558 is an 8 channel Digital Pulse Width Modulator (PWM) with Digital Audio Processing and Sample Rate Converter that provides both advanced performance and a high level of system integration. The TAS5558 is designed to interface seamlessly with most digital audio decoders. TAS5558 is designed to support DTS-HD specification Blu-ray HTiB applications. The ASRC consists of two separate modules which handle 4 channels each. Therefore, it is possible to support up to two different input sampling rates.



Please be aware that an important notice concerning availability, standard warranty, and use in critical applications of Texas Instruments semiconductor products and disclaimers thereto appears at the end of this data sheet.

Matlab is a trademark of Math Works, Inc.

All other trademarks are the property of their respective owners.



These devices have limited built-in ESD protection. The leads should be shorted together or the device placed in conductive foam during storage or handling to prevent electrostatic damage to the MOS gates.

### 1.4 Block Diagram

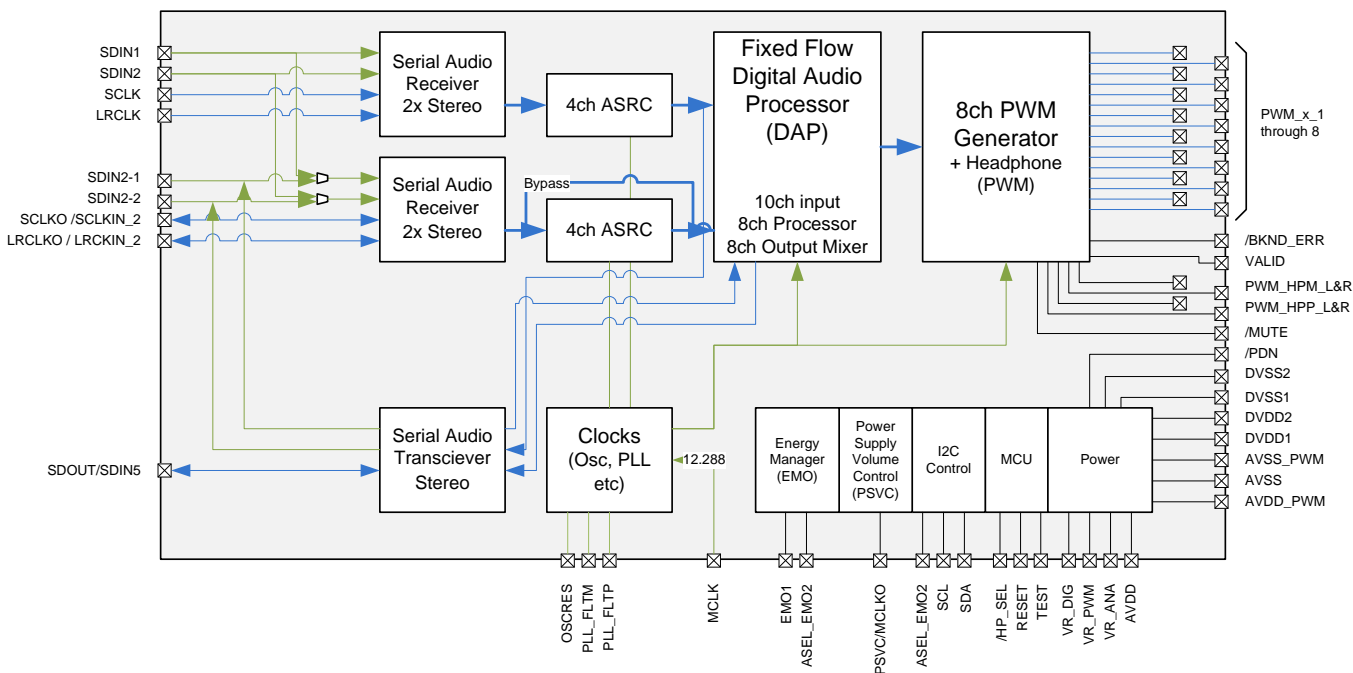

Figure 1-1. Functional Block Diagram

### 1.5 DESCRIPTION (Continued)

The TAS5558 can drive eight channels of H-bridge power stages. Texas Instruments Power Stages are designed to work seamlessly with the TAS5558. The TAS5558 supports either the single-ended or bridge-tied-load configuration. The TAS5558 also provides a high-performance, differential output to drive an external, differential-input, analog headphone amplifier.

The TAS5558 supports AD, BD, and ternary modulation operating at a 384-kHz switching rate for 48-, 96-, and 192-kHz data. The 8x oversampling combined with the fourth-order noise shaper provides a broad, flat noise floor and excellent dynamic range from 20 Hz to 32 kHz.

TAS5558 also features power-supply-volume-control (PSVC) improves dynamic range at lower power level and can be used as part of a Class G Power Supply when used with closed loop PWM input power stages.

## 2 Device Information

### 2.1 Physical Characteristics

#### 2.1.1 TAS5558 Pin Assignments

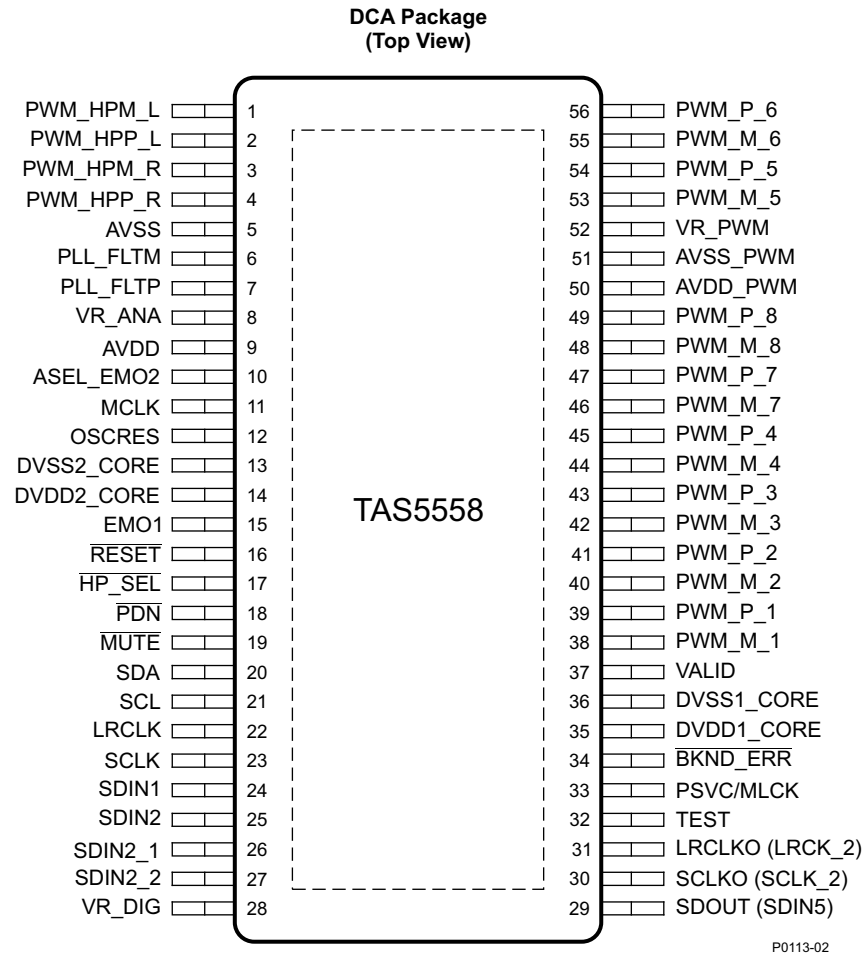

**Figure 2-1. TAS5558 Pinout**

## 2.1.2 Pin Descriptions

PIN		TYPE <sup>(1)</sup>	5-V TOLERANT	TERMINATION <sup>(2)</sup>	DESCRIPTION
NAME	NO.				
ASEL_EMO2	10	DIO		Pullup	I2C Address Select. Address will 0X34/0X36 with the value of pin being "0" or "1" during de-assertion of reset. Can be programmed to be an output (as energy manager output for subwoofer)
AVDD	9	P			Analog supply (3.3 V) for PLL.
AVDD_PWM	50	P			3.3-V analog power supply for PWM. This terminal can be connected to the same power source used to drive power terminal DVDD; but to achieve low PLL jitter, this terminal should be bypassed to AVSS_PWM with a 0.1- $\mu$ F low-ESR capacitor.
AVSS	5	P			Analog ground
AVSS_PWM	51	P			Analog ground for PWM. Must have direct return Cu path to analog 3.3V supply for optimized performance.
$\overline{\text{BKND\_ERR}}$	34	DI		Pullup	Active-low. A back-end error sequence is generated by applying logic low to this terminal. The $\overline{\text{BKND\_ERR}}$ results in no change to I2C parameters, with all H-bridge drive signals going to a hard-mute state (Non PWM Switching).
DVDD1	35	P			3.3-V digital power supply. (It is recommended that decoupling capacitors of 0.1 $\mu$ F and 10 $\mu$ F be mounted close to this pin).
DVDD2	14	P			3.3-V digital power supply for PWM. (It is recommended that decoupling capacitors of 0.1 $\mu$ F and 10 $\mu$ F be mounted close to this pin).
DVSS1	36	P			Digital ground 1
DVSS2	13	P			Digital ground 2
EMO1	15	DO			Energy Manger Output interrupt - Asserted high when threshold is exceeded.
$\overline{\text{HP\_SEL}}$	17	DI	5 V	Pullup	Headphone/speaker selector. When a logic low is applied, the headphone is selected (speakers are off). When a logic high is applied, speakers are selected (headphone is off).
LRCLK	22	DI	5 V	Pulldown	Serial-audio data left/right clock (sampling-rate clock)
LRCLKO / LRCKIN_2	31	DIO	5V	Pulldown	LRCLK for I2S OUT. Can also be used as LRCKIN_2 (I2S Input for SDIN2_x and SRC Bank 2)
MLCK	11	DI			3.3-V master clock input. The input frequency of this clock can range from 2 MHz to 50 MHz.
$\overline{\text{MUTE}}$	19	DI	5 V	Pullup	Soft mute of outputs, active-low (muted signal = a logic low, normal operation = a logic high). The mute control provides a noiseless volume ramp to silence. Releasing mute provides a noiseless ramp to previous volume.
OSCRES	12	DO		1M $\Omega$ Resistor	Oscillator resistor (1% tolerance).
$\overline{\text{PDN}}$	18	DI	5 V	Pullup	Power down, active-low. $\overline{\text{PDN}}$ powers down all logic and stops all clocks whenever a logic low is applied. The I2C parameters are preserved through a power-down cycle, as long as $\overline{\text{RESET}}$ is not active.
PLL_FLTM	6	AIO			PLL negative filter.
PLL_FLTP	7	AIO			PLL positive filter.
PSVC/MCLKO	33	DO			Power-supply volume control PWM output or MCKO for external ADC (SDIN5 Source)
PWM_HPM_L	1	DO			PWM left-channel headphone (differential -)
PWM_HPM_R	3	DO			PWM right-channel headphone (differential -)
PWM_HPP_L	2	DO			PWM left-channel headphone (differential +)
PWM_HPP_R	4	DO			PWM right-channel headphone (differential +)
PWM_M_1	38	DO			PWM 1 output (differential -)
PWM_M_2	40	DO			PWM 2 output (differential -)
PWM_M_3	42	DO			PWM 3 output (differential -)
PWM_M_4	44	DO			PWM 4 output (differential -)
PWM_M_5	53	DO			PWM 5 output (lineout L) (differential -)
PWM_M_6	55	DO			PWM 6 output (lineout R) (differential -)
PWM_M_7	46	DO			PWM 7 output (differential -)
PWM_M_8	48	DO			PWM 8 output (differential -)
PWM_P_1	39	DO			PWM 1 output (differential +)

(1) Type: A = analog; D = 3.3-V digital; P = power/ground/decoupling; I = input; O = output

(2) All pullups are 20- $\mu$ A weak pullups and all pulldowns are 20- $\mu$ A weak pulldowns. The pullups and pulldowns are included to ensure proper input logic levels if the terminals are left unconnected (pullups  $\rightarrow$  logic-1 input; pulldowns  $\rightarrow$  logic-0 input). Devices that drive inputs with pullups must be able to sink 20  $\mu$ A while maintaining a logic-0 drive level. Devices that drive inputs with pulldowns must be able to source 20  $\mu$ A while maintaining a logic-1 drive level.

PIN		TYPE <sup>(1)</sup>	5-V TOLERANT	TERMINATION <sup>(2)</sup>	DESCRIPTION
NAME	NO.				
PWM_P_2	41	DO			PWM 2 output (differential +)
PWM_P_3	43	DO			PWM 3 output (differential +)
PWM_P_4	45	DO			PWM 4 output (differential +)
PWM_P_5	54	DO			PWM 5 output (lineout L) (differential +)
PWM_P_6	56	DO			PWM 6 output (lineout R) (differential +)
PWM_P_7	47	DO			PWM 7 output (differential +)
PWM_P_8	49	DO			PWM 8 output (differential +)
RESET	16	DI	5 V	Pullup	System reset input, active-low. A system reset is generated by applying a logic low to this terminal. RESET is an asynchronous control signal that restores the TAS5558 to its default conditions, sets the valid output low, and places the PWM in the hard-mute state (Non PWM Switching). Master volume is immediately set to full attenuation. On the release of RESET, if PDN is high, the system performs a 4- to 5-ms device initialization and sets the volume at mute.
SCL	21	DI	5 V		I <sup>2</sup> C serial-control clock input/output
SCLK	23	DI	5 V	Pulldown	Serial-audio data clock (shift clock) input
SCLKO / SCLKIN_2	30	DIO	5V	Pulldown	Serial data clock out. I2S bit clock out. Can also be used as SCLKIN_2 (I2S Input for SDIN2_x and SRC Bank 2)
SDA	20	DIO	5 V		I <sup>2</sup> C serial-control data-interface input/output
SDIN1	24	DI	5 V	Pulldown	Serial-audio data bank 1 input 1 is one of the serial-data input ports and goes into the 1st SRC Bank. Four discrete (stereo) data formats and is capable of inputting data at 64 f <sub>s</sub> .
SDIN2	25	DI	5 V	Pulldown	Serial-audio data bank 1 input 2 is one of the serial-data input ports and goes into the 1st SRC Bank. Four discrete (stereo) data formats and is capable of inputting data at 64 f <sub>s</sub> .
SDIN2-1	26	DI	5 V	Pulldown	Serial-audio data bank 2 input 1 is one of the serial-data input ports and goes into the 2nd SRC Bank. Four discrete (stereo) data formats and is capable of inputting data at 64 f <sub>s</sub> .
SDIN2-2	27	DI	5 V	Pulldown	Serial-audio data bank 2 input 2 is one of the serial-data input ports and goes into the 2nd SRC Bank. Four discrete (stereo) data formats and is capable of inputting data at 64 f <sub>s</sub> .
SDOUT / SDIN5	29				I2S data out or SDIN5 (must be sync'd to post SRC rate). Usually used for Microphone ADC Input
TEST	32	DI			Test mode active high. In normal mode tie this to digital ground.
VALID	37	DO			Output indicating validity of PWM outputs, active-high
VR_DIG	28	P			Voltage reference for 1.8-V digital core supply. A pinout of the internally regulated 1.8-V power used by digital core logic. A 4.7-μF low-ESR capacitor <sup>(3)</sup> should be connected between this terminal and DVSS. This terminal must not be used to power external devices.
VR_PWM	52	P			Voltage reference for 1.8-V digital PLL supply. A pinout of the internally regulated 1.8-V power used by digital PLL logic. A 0.1-μF low-ESR capacitor <sup>(3)</sup> should be connected between this terminal and DVSS_CORE. This terminal must not be used to power external devices.
VR_ANA	8	P			

- (3) If desired, low-ESR capacitance values can be implemented by paralleling two or more ceramic capacitors of equal value. Paralleling capacitors of equal value provides an extended high-frequency supply decoupling. This approach avoids the potential of producing parallel resonance circuits that have been observed when paralleling capacitors of different values.

## 2.2 ORDERING INFORMATION

Orderable Device	Package	Pins
TAS5558DCA	DCA	56
TAS5558DCAR	DCA	56

## 2.3 THERMAL INFORMATION

THERMAL METRIC <sup>(1)</sup>		TAS5558	UNITS
		DCA (56 PINS)	
$\theta_{JA}$	Junction-to-ambient thermal resistance	26.1	°C/W
$\theta_{JCTop}$	Junction-to-case thermal resistance	13	
$\theta_{JB}$	Junction-to-board thermal resistance	8	
$\Psi_{JT}$	Junction-to-top characterization parameter	0.4	
$\Psi_{JB}$	Junction-to-board characterization parameter	7.9	
$\theta_{JCbott}$	Junction-to-case(bottom) thermal resistance	0.4	

(1) For more information about traditional and new thermal metrics, see the IC Package Thermal Metrics application report, [SPRA953](#)

## 2.4 TAS5558 Functional Description

Figure 1-1 shows the TAS5558 functional structure. The following sections describe the TAS5558 functional blocks:

- Power Supply
- Clock, PLL, and Serial Data Interface
- Serial Control Interface
- Device Control
- Digital Audio Processor
- PWM Section
- 8 Channel ASRC

### 2.4.1 Power Supply

The power-supply section contains 1.8 V supply regulators that provide analog and digital regulated power for various sections of the TAS5558. The analog supply supports the analog PLL, whereas digital supplies support the digital PLL, the digital audio processor (DAP), the pulse-width modulator (PWM), and the output control.

### 2.4.2 Clock, PLL, and Serial Data Interface

In the TAS5558, the internal master clock is derived from the MCLK input and the internal sampling rate will be either 88.1 kHz/96 kHz (double speed mode) or 174.2 kHz/192 kHz (quad speed mode).

There is a fifth (I2S input) SAP input that will not go through the ASRC. Due to this, this fifth SAP input will be always slave to internal master clock.

When ASRC is bypassed, the internal master clock is generated by the MCLK input, the I2S master mode must be activated in order to accept SDIN1-5.

The secondary sampling rate must not be activated when ASRC is bypassed. This is to specify proper audio signal flow throughout the system.

Due to the limitation in the ASRC block, in quad speed mode the number of supported channels will be halved, which happens when the ASRC is set into a certain mode. In this mode, only one serial audio input (two channels) will be processed per ASRC module and its output will be copied to the other two channels at the ASRC output.

The TAS5558 uses an internal trimmed oscillator to provide a time base for:

- Continuous data and clock error detection and management
- Automatic data-rate detection and configuration
- Automatic MCLK-rate detection and configuration (automatic bank switching)
- Supporting I<sup>2</sup>C operation/communication while MCLK is absent

The TAS5558 automatically handles clock errors, data-rate changes, and master-clock frequency changes without requiring intervention from an external system controller. This feature significantly reduces system complexity and design.

### 2.4.3 Serial Audio Interface

The TAS5558 has five PCM serial data interfaces to permit eight channels of digital data to be received through the SDIN1-1, SDIN1-2, SDIN2-1, SDIN2-2 and SDIN5 inputs. The device also has one serial audio output. The serial audio data is in MSB-first, 2s-complement format.

The serial data input interface can be configured in right-justified, I<sup>2</sup>S or left-justified. The serial data interface format is specified using the I<sup>2</sup>C data-interface control register. The supported formats and word lengths are shown in [Table 2-1](#).

**Table 2-1. Serial Data Formats**

RECEIVE SERIAL DATA FORMAT	WORD LENGTH
Right-justified	16
Right-justified	20
Right-justified	24
I <sup>2</sup> S	16
I <sup>2</sup> S	20
I <sup>2</sup> S	24
Left-justified	16
Left-justified	20
Left-justified	24

Serial data is input on SDIN1-5. The device will accept 32, 44.1, 48, 88.2, 96, 176.4 and 192 kHz serial data in 16, 20 or 24-bit data in Left, Right and I2S serial data formats using a 64 Fs SCLK clock and a 128, 192, 256, 384, or 512 \* Fs MCLK rates (up to a maximum of 50 MHz).

Serial Data is output on SDOUT. The SDOUT data format is I2S 24 bit.

The parameters of this clock and serial data interface are I2C configurable. But the default is autodetect.

### 2.4.4 I<sup>2</sup>C Serial-Control Interface

The TAS5558 has an I<sup>2</sup>C serial-control slave interface to receive commands from a system controller. The serial-control interface supports both normal-speed (100-kHz) and high-speed (400-kHz) operations without wait states. The TAS5558 has a internal oscillator, this allows the interface to operate even when MCLK is absent.

The serial control interface supports both single-byte and multiple-byte read/write operations for status registers and the general control registers associated with the PWM. However, for the DAP data-processing registers, the serial control interface also supports multiple-byte (4-byte) write operations.



The I<sup>2</sup>C supports a special mode which permits I<sup>2</sup>C write operations to be broken up into multiple data-write operations that are multiples of 4 data bytes. These are 6-byte, 10-byte, 14-byte, 18-byte, etc., write operations that are composed of a device address, read/write bit, subaddress, and any multiple of 4 bytes of data. This permits the system to incrementally write large register values with multiple 4 byte transfers. I<sup>2</sup>C transactions. In order to use this feature, the first block of data is written to the target I<sup>2</sup>C address, and each subsequent block of data is written to a special append register (0xFE) until all the data is written and a stop bit is sent. An incremental read operation is not supported using 0xFE.

### 2.4.5 Device Control

The control section provides the control and sequencing for the TAS5558. The device control provides both high- and low-level control for the serial control interface, clock and serial data interfaces, digital audio processor, and pulse-width modulator sections.

### 2.4.6 Energy Manager

Energy Manager monitors the overall energy (power) in the system. It can be programmed to monitor the energy of all channels or satellite and sub separately. The output of energy manager, all called EMO, is a flag that is set when the energy level crosses above the programmed threshold. This level is indicated in internal status registers as well as in pin output.

### 2.4.7 Digital Audio Processor (DAP)

The DAP arithmetic unit is used to implement all audio-processing functions: soft volume, loudness compensation, bass and treble processing, dynamic range control, channel filtering, and input and output mixing. [Figure 3-1](#) shows the TAS5558 DAP architecture.

#### 2.4.7.1 TAS5558 Audio-Processing Configurations

The 32-kHz to 96-kHz configuration supports eight channels of data processing that can be configured either as eight channels, or as six channels with two channels for separate stereo line outputs. All data is SRC'd to 96kHz in this mode, and processed in the DAP at 96kHz.

The 176.4-kHz to 192-kHz configuration supports four channels of signal processing with two channels passed through (or derived from the three processed channels).

To support efficiently the processing requirements of both multichannel 32-kHz to 96-kHz data and the 6-channel 176.4-kHz and 192-kHz data, the TAS5558 has separate audio-processing features for 32-kHz to 96-kHz data rates and for 176.4 kHz and 192 kHz. See [Table 2-2](#) for a summary of TAS5558 processing feature sets.

### 2.4.7.2 TAS5558 Audio-Processing Feature Sets

The audio processing architecture of the TAS5558 DAP for normal and double speed configurations is shown below.

**Table 2-2. TAS5558 Audio-Processing Feature Sets**

FEATURE	32 kHz–96 kHz 8-CHANNEL FEATURE SET	32 kHz–96 kHz 6 + 2 LINEOUT FEATURE SET	176.4- and 192-kHz FEATURE SET
Signal-processing channels	8	6 + 2	4
Master volume	1 for 8 channels	1 for 6 channels	1 for 4 channels
Individual channel volume controls	8		4
Bass and treble tone controls	Four bass and treble tone controls with $\pm 18$ -dB range, programmable corner frequencies, and second-order slopes L, R, and C LS, RS LBS, RBS Sub	Four bass and treble tone controls with $\pm 18$ -dB range, programmable corner frequencies, and second-order slopes L, R, and C LS, RS Sub Line L and R	Two bass and treble tone controls with $\pm 18$ -dB range, programmable corner frequencies, and second-order slopes for satellite channels (selectable). One Bass Control for Sub (channel 8)
Biquads	56		31
Dynamic range compressors	1 for 7 satellites and 1 for sub	1 for satellites and 1 for sub (Line 1 and 2 Uncompressed)	2 - 1 for 3 satellites and 1 for sub
Input/output mapping/mixing	Each of the eight signal-processing channels input can be any ratio of the eight input channels. Each of the eight outputs can be any ratio of any two processed channels.		Channels 1, 2, 5, 6 has 4x1 mixer on the output and input
DC-blocking filters (implemented in PWM section)	Eight channels		
Digital de-emphasis (implemented in PWM section)	Eight channels for 32 kHz, 44.1 kHz, and 48 kHz	Six channels for 32 kHz, 44.1 kHz, and 48 kHz	N/A
Loudness	Eight channels	Six channels	Four channels
Number of coefficient sets stored	Two additional coefficient sets can be stored in memory. (Bank Switching data for ASRC Bypass Mode)		

### 2.4.8 Pulse Width Modulation Schemes

TAS5558 supports three PWM modulations schemes: AD Mode, BD Mode and Ternary Mode. Ternary mode is selected using register 0X25, bit D5. For AD and BD Modulation schemes, this bit should be set to 0. AD/BD mode is selected via input mux registers 0X30-0X33. Following PWM timing diagram shows the three different schemes.

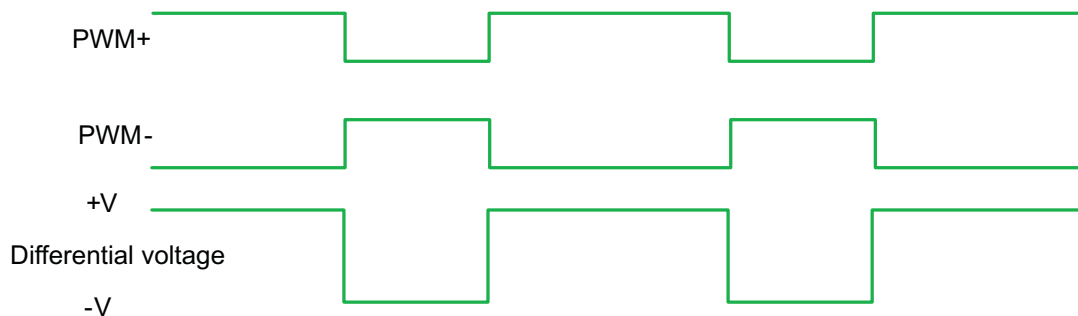

**Figure 2-2. AD Modulation**

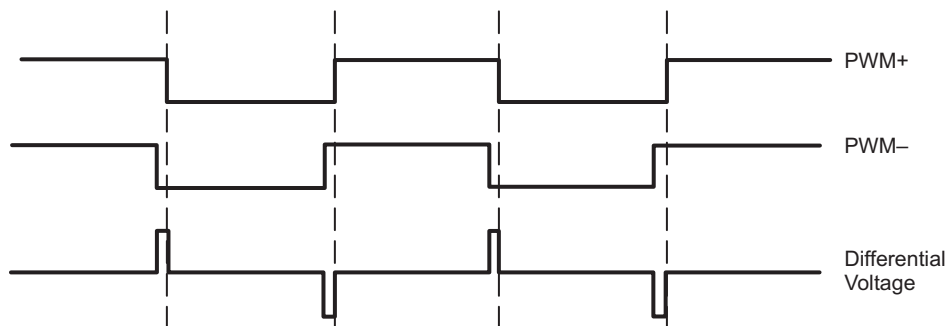

**Figure 2-3. BD Modulation**

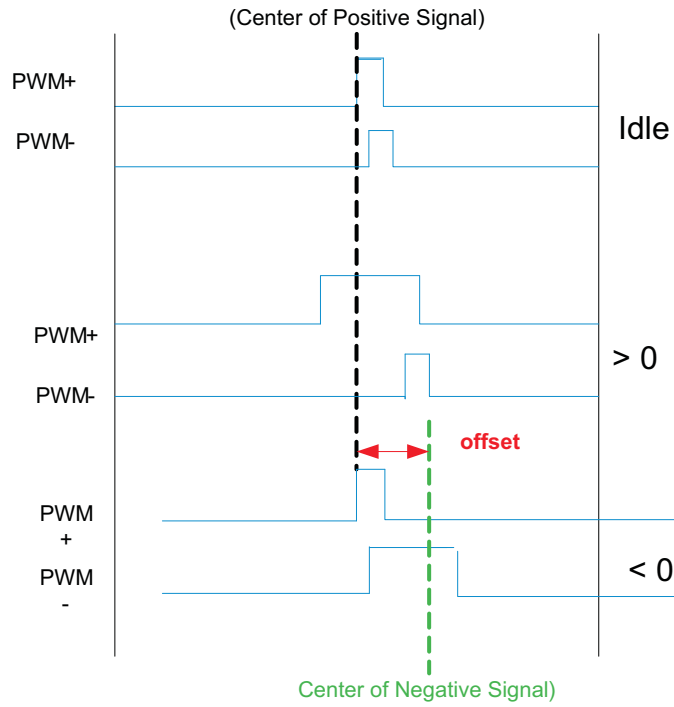

**Figure 2-4. Ternary Modulation**

### 3 TAS5558 DAP Architecture

#### 3.1 TAS5558 DAP Architecture Diagrams

The TAS5558 defaults to processing audio data (post ASRC) at double rate.. In the TAS5558, this is also set to 96kHz/88.2kHz based on the MCLK provided along with the I2S data. Additional support is provided for native 192kHz support. 4ch of audio processing is available in 192kHz native processing mode.

Figure 3-1 shows the TAS5558 DAP architecture for  $f_s \leq 96$  kHz. The bass management architecture is shown in channels 1, 2, 7 and 8. The I2C registers are shown to help the designer configure the device.

Figure 3-2 shows the architecture for  $f_s = 176.4$  kHz or  $f_s = 192$  kHz. Note that only channels 1, 2, and 8 contain all the features. Channels 3–7 are pass-through except for volume controls.

Figure 3-3 shows TAS5558 detailed channel processing. The output mixer is 8x2 for channels 1–6 and 8x3 for channels 7 and 8.

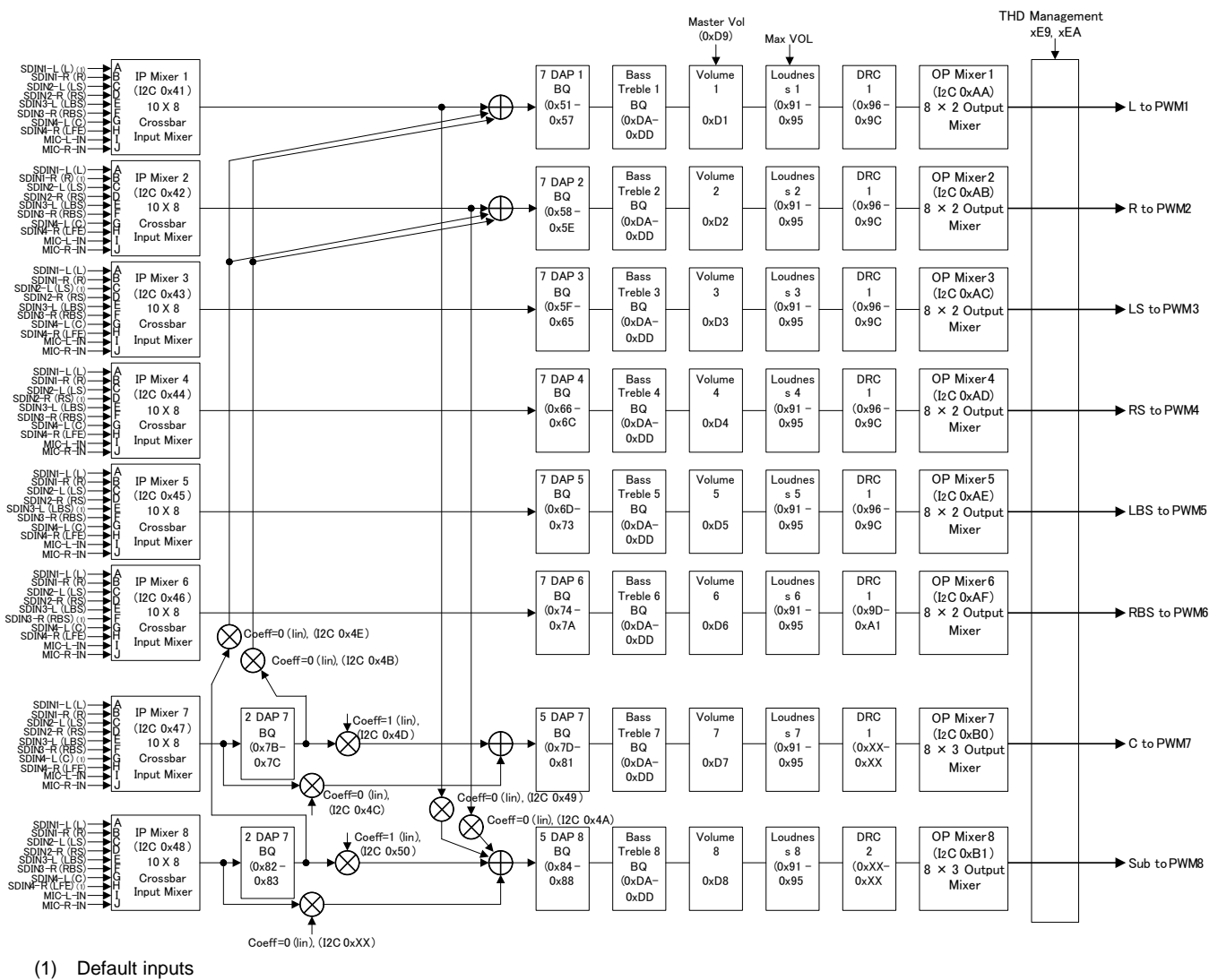
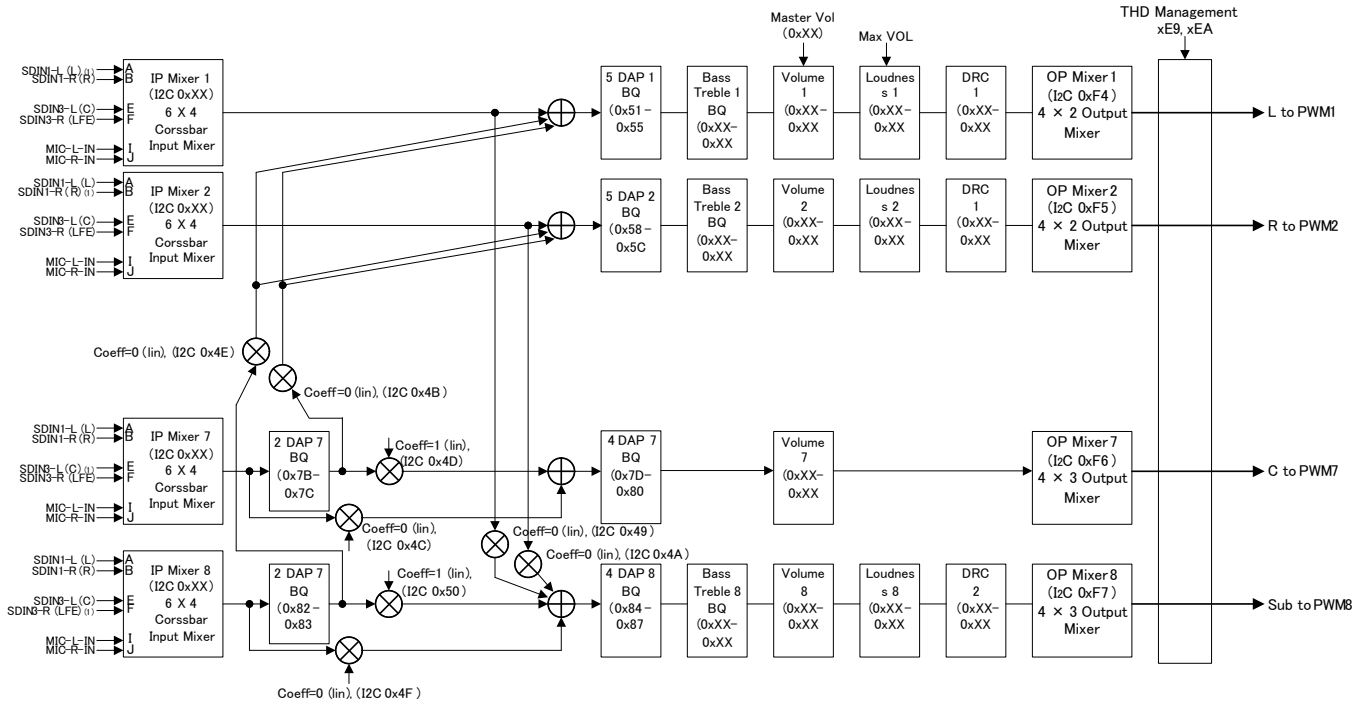
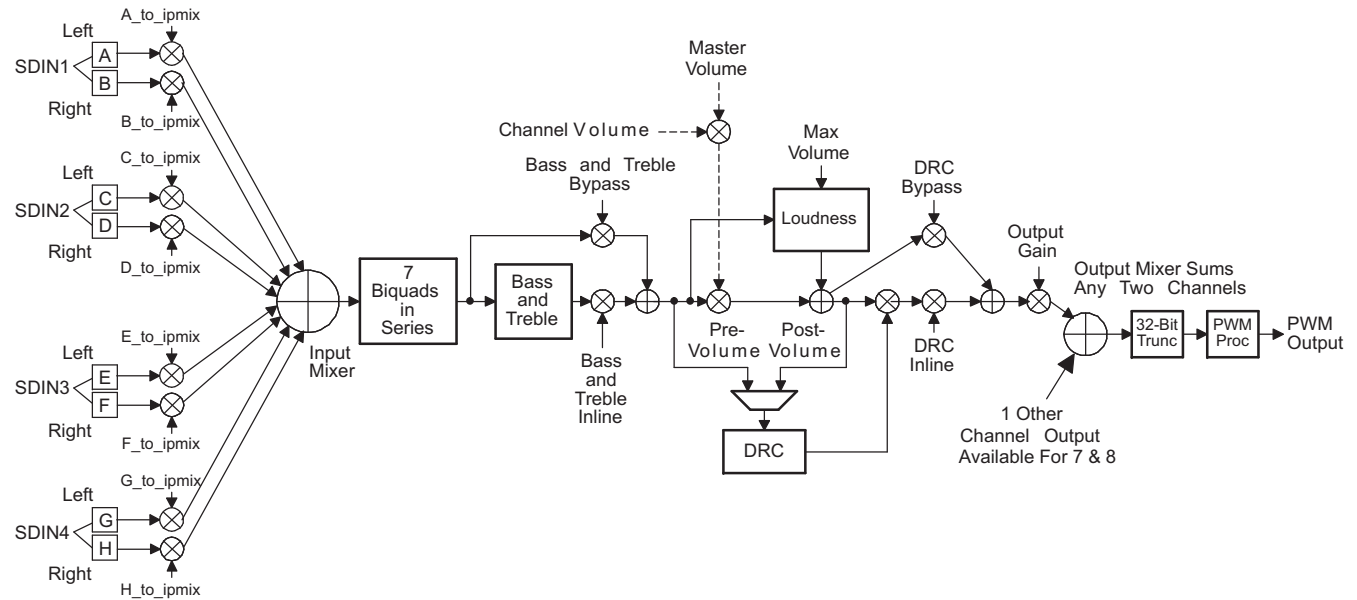

Figure 3-1. TAS5558 DAP Architecture With I<sup>2</sup>C Registers ( $f_s \leq 96$  kHz)



(1) Default inputs

**Figure 3-2. TAS5558 Architecture With I<sup>2</sup>C Registers in 192kHz Native Mode ( $f_s = 176.4 \text{ kHz}$  or  $f_s = 192 \text{ kHz}$ )**



B0016

**Figure 3-3. TAS5558 Detailed Channel Processing**

### 3.2 I<sup>2</sup>C Coefficient Number Formats

The architecture of the TAS5558 is contained in ROM resources within the device and cannot be altered. However, mixer gain, level offset, and filter tap coefficients, which can be entered via the I<sup>2</sup>C bus interface, provide a user with the flexibility to set the TAS5558 to a configuration that achieves system-level goals.

The firmware is executed in a 32-bit, signed, fixed-point arithmetic machine. The most significant bit of the 32-bit data path is a sign bit, and the 31 lower bits are data bits. Mixer gain operations are implemented by multiplying a 32-bit, signed data value by a 28-bit, signed gain coefficient (known as 5.23 in the rest of this document. See for more details). The 60-bit, signed output product is then truncated to a signed, 32-bit number. Level offset operations are implemented by adding a 32-bit, signed offset coefficient to a 32-bit, signed data value.

In most cases, if the addition results in overflowing the 32-bit, signed number format, saturation logic is used. This means that if the summation results in a positive number that is greater than 0x7FFF FFFF FF (the spaces are used to ease the reading of the hexadecimal number), the number is set to 0x7FFF FFFF FF. If the summation results in a negative number that is less than 0x8000 0000 00, the number is set to 0x8000 0000 00. This allows the system to clip in a similar way to an analog circuit, rather than "wrapping around" to a polar opposite output.

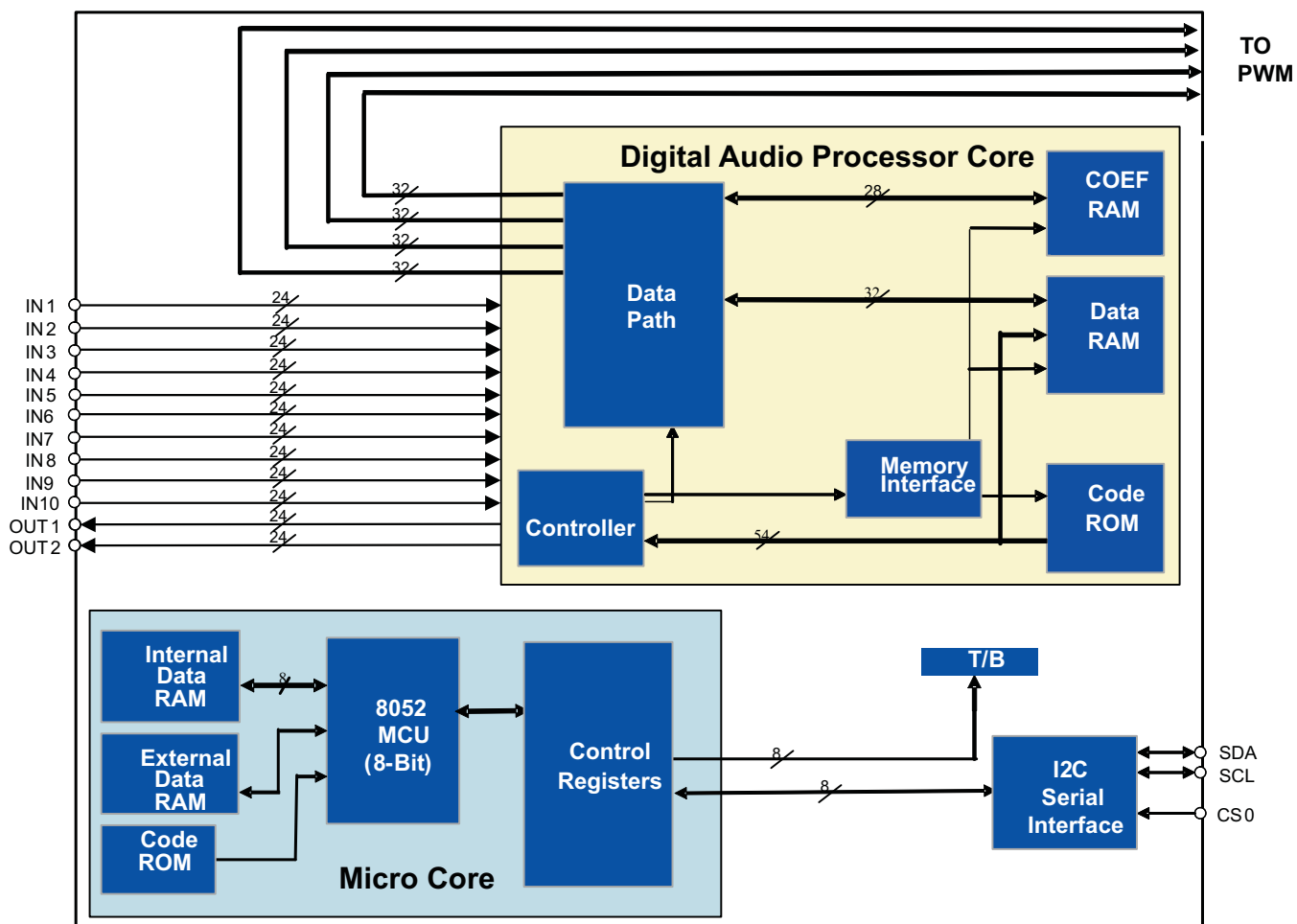

Figure 3-4. DAP Block Diagram

### 3.2.1 Digital Audio Processor (DAP) Arithmetic Unit

The digital audio processor (DAP) arithmetic unit is a fixed-point computational engine consisting of an arithmetic unit and data and coefficient memory blocks.

The DAP arithmetic unit is used to implement all firmware functions - loudness compensation, bass and treble processing, dynamic range control, channel filtering, input and output mixing.

Figure 3-5 shows the data word structure of the DAP arithmetic unit. Four bits of overhead or guard bits are provided at the upper end of the 32-bit DAP word, and 4 bits of computational precision or noise bits are provided at the lower end of the 32-bit word. The incoming digital audio words are all positioned with the most significant bit abutting the 4-bit overhead/guard boundary. The sign bit in bit 31 indicates that all incoming audio samples are treated as signed data samples.

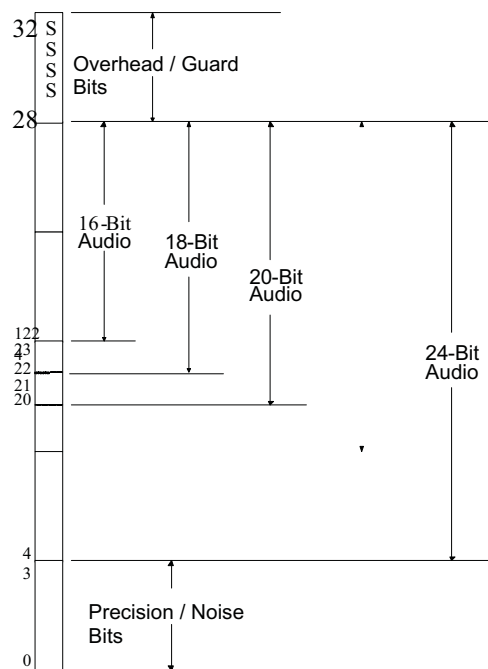

**Figure 3-5. DAP Arithmetic Unit Data Word Structure**

The arithmetic engine is a 32-bit (9.23 format) processor consisting of a general-purpose 60-bit arithmetic logic unit and function-specific arithmetic blocks. Multiply operations (excluding the function-specific arithmetic blocks) always involve 32-bit (9.23) DAP words and 28-bit (5.23) coefficients (usually I2C programmable coefficients). If a group of products are to be added together, the 60-bit product of each multiplication is applied to a 60-bit adder, where a DSP-like multiply-accumulate (MAC) operation takes place. Biquad filter computations use the MAC operation to maintain precision in the intermediate computational stages.

To maximize the linear range of the 76-bit ALU, saturation logic is not used. In MAC computations, intermediate overflows are permitted, and it is assumed that subsequent terms in the computation flow will correct the overflow condition. The biquad filter structure used in the TAS5558 is the “direct form I” structure and has only one accumulation node (for an example, see the [Biquad section](#)). With this type of structure, intermediate overflow are allowable as long as the designer of the filters has assured that the final output will be bounded and not overflow. Figure 4.2-3 is an example, using 16-bit arithmetic for ease of illustration, of a bounded computation that experiences intermediate overflow condition.

The DAP memory banks include a dual port data RAM for storing intermediate results, a coefficient RAM, and a fixed program ROM. Only the coefficient RAM, assessable via the I2C bus, is available to the user.



		8-Bit ALU Operation (Without Saturation)		
		10110111	(-73)	-73
		+ 11001101	(-51)	+ -51
		<hr style="width: 100%; border: 0.5px solid black;"/>		<hr style="width: 100%; border: 0.5px solid black;"/>
		10000100	(-124)	-124
		+ 11010011	(-45)	+ -45
		<hr style="width: 100%; border: 0.5px solid black;"/>		<hr style="width: 100%; border: 0.5px solid black;"/>
Rollover	→	01010111	(57)	-169
		+ 00111011	(59)	+ 59
		<hr style="width: 100%; border: 0.5px solid black;"/>		<hr style="width: 100%; border: 0.5px solid black;"/>
		10010010	(-110)	-110

**Figure 3-6. DAP ALU Operation With Intermediate Overflow**

### 3.2.2 28-Bit 5.23 Number Format

All mixer gain coefficients are 28-bit coefficients using a 5.23 number format. Numbers formatted as 5.23 numbers have 5 bits to the left of the binary point and 23 bits to the right of the binary point. This is shown in Figure 3-7.

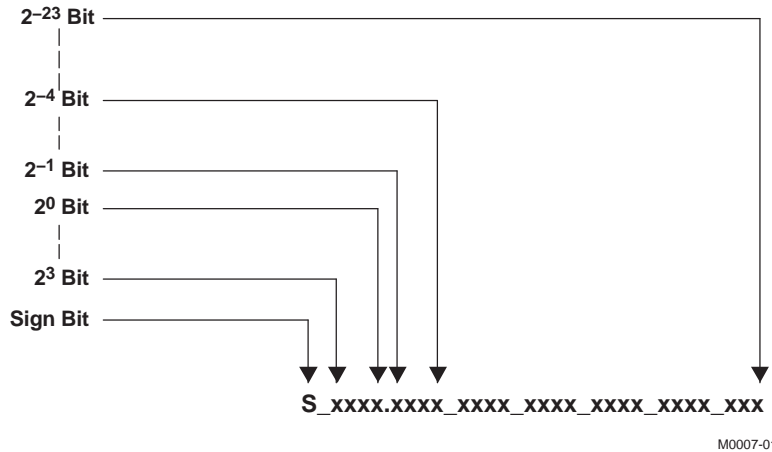

Figure 3-7. 5.23 Format

The decimal value of a 5.23 format number can be found by following the weighting shown in Figure 3-8. If the most significant bit is logic 0, the number is a positive number, and the weighting shown yields the correct number. If the most significant bit is a logic 1, then the number is a negative number. In this case, every bit must be inverted, a 1 added to the result, and then the weighting shown in Figure 3-8 applied to obtain the magnitude of the negative number.

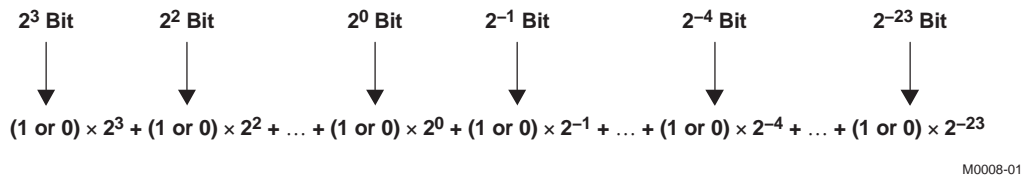
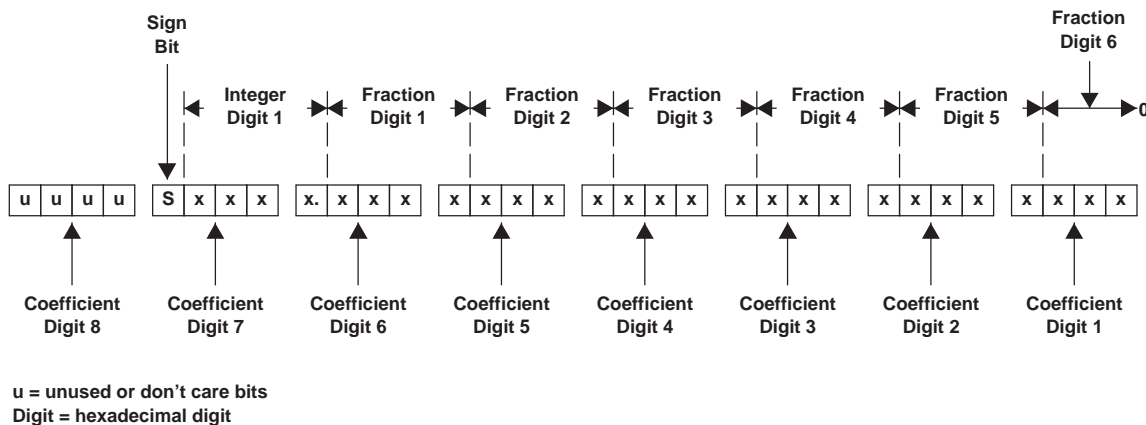

Figure 3-8. Conversion Weighting Factors—5.23 Format to Floating Point

Gain coefficients, entered via the I<sup>2</sup>C bus, must be entered as 32-bit binary numbers. The format of the 32-bit number (4-byte or 8-digit hexadecimal number) is shown in Figure 3-9.



u = unused or don't care bits  
Digit = hexadecimal digit

Figure 3-9. Alignment of 5.23 Coefficient in 32-Bit I<sup>2</sup>C Word

As Figure 3-9 shows, the hexadecimal (hex) value of the integer part of the gain coefficient cannot be concatenated with the hex value of the fractional part of the gain coefficient to form the 32-bit I<sup>2</sup>C coefficient. The reason is that the 28-bit coefficient contains 5 bits of integer, and thus the integer part of the coefficient occupies all of one hex digit and the most significant bit of the second hex digit. In the same way, the fractional part occupies the lower three bits of the second hex digit, and then occupies the other five hex digits (with the eighth digit being the zero-valued most significant hex digit).

### 3.2.3 TAS5558 Audio Processing

The TAS5558 digital audio processing is designed so that noise produced by filter operations is maintained below the smallest signal amplitude of interest, as shown in Figure 3-10. The device achieves this low noise level by increasing the precision of the signal representation substantially above the number of bits that are absolutely necessary to represent the input signal.

Similarly, the TAS5558 carries additional precision in the form of overflow bits to permit the value of intermediate calculations to exceed the input precision without clipping. The TAS5558's advanced digital audio processor achieves both of these important performance capabilities by using a high-performance digital audio-processing architecture with a 32-bit data path, 28-bit filter coefficients, and a 60-bit accumulator.

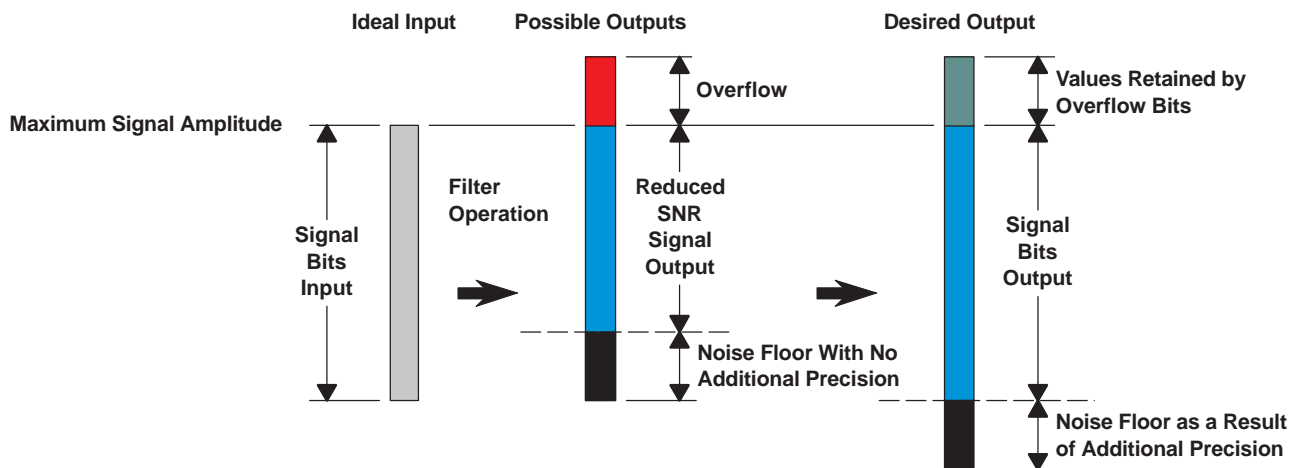

M0010-01

Figure 3-10. TAS5558 Digital Audio Processing

### 3.3 Input Crossbar Mixer

The TAS5558 has a full 10×8 input crossbar mixer. This mixer permits each signal-processing channel input to be any mix of any of the eight input channels, as shown in Figure 3-11. The control parameters for the input crossbar mixer are programmable via the I<sup>2</sup>C interface. See the *Input Mixer Registers, Channels 1–8 (0x41–0x48)*, Section 11.22, for more information.

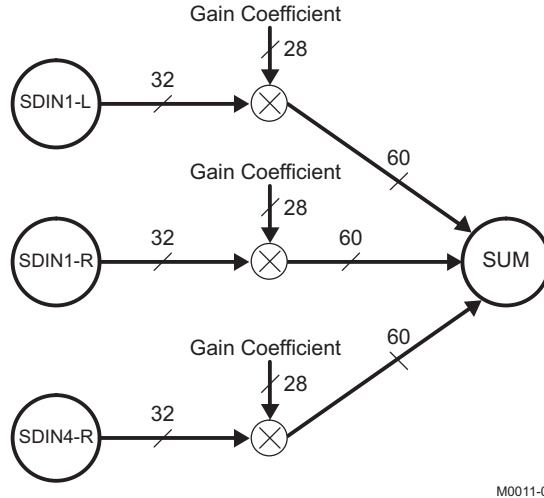

Figure 3-11. Input Crossbar Mixer

### 3.4 Biquad Filters

For 32-kHz to 96-kHz data, the TAS5558 provides 56 biquads across the eight channels (seven per channel).

For 176.4-kHz and 192-kHz data, the TAS5558 has 32 biquads across the three channels (seven per channel).

The direct form I structure provides a separate delay element and mixer (gain coefficient) for each node in the biquad filter. Each mixer output is a signed 60-bit product of a signed 32-bit data sample (9.23 format number) and a signed 28-bit coefficient (5.23 format number), as shown in Figure 3-12. The 60-bit ALU in the TAS5558 allows the 60-bit resolution to be retained when summing the mixer outputs (filter products). All of the biquad filters are second-order direct form I structure.

The five 28-bit coefficients for the each of the 56 biquads are programmable via the I<sup>2</sup>C interface. See Table 3-1.

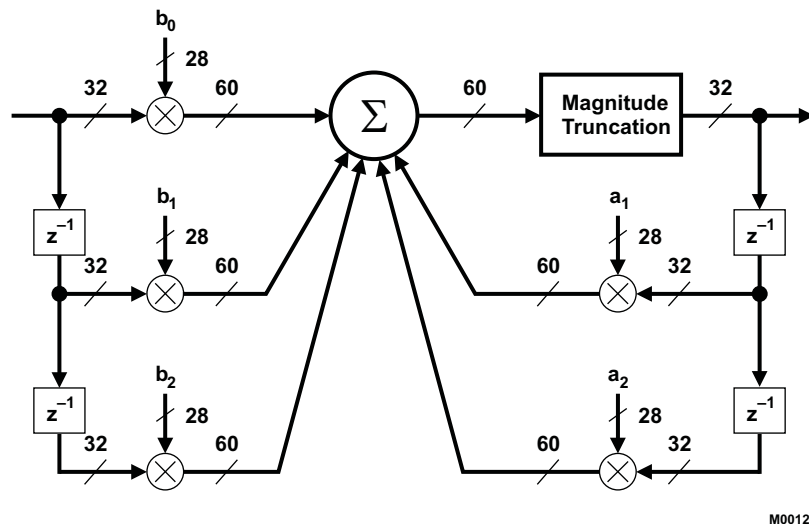

Figure 3-12. Biquad Filter Structure

All five coefficients for one biquad filter structure are written to one I<sup>2</sup>C register containing 20 bytes (or five 32-bit words). The structure is the same for all biquads in the TAS5558. Registers 0x51–0x88 show all the biquads in the TAS5558. Note that u[31:28] bits are unused and default to 0x0.

**Table 3-1. Contents of One 20-Byte Biquad Filter Register (Default = All-Pass)**

DESCRIPTION	REGISTER FIELD CONTENTS	INITIALIZATION GAIN COEFFICIENT VALUE	
		DECIMAL	HEX
b <sub>0</sub> coefficient	u[31:28], b0[27:24], b0[23:16], b0[15:8], b0[7:0]	1.0	0x00, 0x80, 0x00, 0x00
b <sub>1</sub> coefficient	u[31:28], b1[27:24], b1[23:16], b1[15:8], b1[7:0]	0.0	0x00, 0x00, 0x00, 0x00
b <sub>2</sub> coefficient	u[31:28], b2[27:24], b2[23:16], b2[15:8], b2[7:0]	0.0	0x00, 0x00, 0x00, 0x00
a <sub>1</sub> coefficient	u[31:28], a1[27:24], a1[23:16], a1[15:8], a1[7:0]	0.0	0x00, 0x00, 0x00, 0x00
a <sub>2</sub> coefficient	u[31:28], a2[27:24], a2[23:16], a2[15:8], a2[7:0]	0.0	0x00, 0x00, 0x00, 0x00

### 3.5 Bass and Treble Controls

In post-SRC 96kHz processing mode, the TAS5558 has four bass and treble tone control groups. Each control has a ±18-dB control range with selectable corner frequencies and second-order slopes. These controls operate four channel groups:

- L, R, and C (channels 1, 2, and 7)
- LS, RS (channels 3 and 4)
- LBS, RBS (alternatively called L and R lineout) (channels 5 and 6)
- Sub (channel 8)

For post-SRC 192-kHz data, the TAS5558 has two bass and treble tone controls. Each control has a  $\pm 18$ -dB I<sup>2</sup>C control range with selectable corner frequencies and second-order slopes. These controls operate two channel groups:

- L, R and C
- Sub
  - Sub only has bass and no treble.

The bass and treble filters use a soft update rate that does not produce artifacts during adjustment.

**Table 3-2. Bass and Treble Filter Selections**

f <sub>s</sub> (kHz)	3-dB CORNER FREQUENCIES, Hz									
	FILTER SET 1		FILTER SET 2		FILTER SET 3		FILTER SET 4		FILTER SET 5	
	BASS	TREBLE	BASS	TREBLE	BASS	TREBLE	BASS	TREBLE	BASS	TREBLE
88.2	115	2527	230	5053	345	8269	402	10106	459	11944
96	125	2750	250	5500	375	9000	438	11000	500	13000
176.4	230	5053	459	10106	689	16538	804	20213	919	23888
192	250	5500	500	11000	750	18000	875	22000	1000	26000

The I<sup>2</sup>C registers that control bass and treble are:

- Bass and treble bypass register (0x89–0x90, channels 1–8)
- Bass and treble slew rates (0xD0)
- Bass filter sets 1–5 (0xDA)
- Bass filter index (0xDB)
- Treble filter sets 1–5 (0xDC)
- Treble filter index (0xDD)

#### NOTE

The bass and treble bypass registers (0x89–0x90) are defaulted to the bypass mode. In order to use the bass and treble, these registers must be in the inline (or enabled) mode for each channel using bass and treble.

### 3.6 Volume, Automute, and Mute

The TAS5558 provides individual channel and master volume controls. Each control provides an adjustment range of 18 dB to –127 dB in 0.25-dB increments. This permits a total volume device control range of 36 dB to –127 dB plus mute. The master volume control can be configured to control six or eight channels.

The TAS5558 has a master soft mute control that can be enabled by a terminal or I<sup>2</sup>C command. The device also has individual channel soft mute controls that are enabled via I<sup>2</sup>C.

### 3.7 Loudness Compensation

The loudness compensation function compensates for the Fletcher-Munson loudness curves. The TAS5558 loudness implementation tracks the volume control setting to provide spectral compensation for weak low- or high-frequency response at low volume levels. For the volume tracking function, both linear and logarithmic control laws can be implemented. Any biquad filter response can be used to provide the desired loudness curve. The control parameters for the loudness control are programmable via the I<sup>2</sup>C interface.

The TAS5558 has a single set of loudness controls for the eight channels. In 6-channel mode, loudness is available to the six speaker outputs and also to the line outputs. The loudness control input uses the maximum individual master volume (V) to control the loudness that is applied to all channels. In the 192-kHz and 176.4-kHz modes, the loudness function is active only for channels 1, 2, and 8.

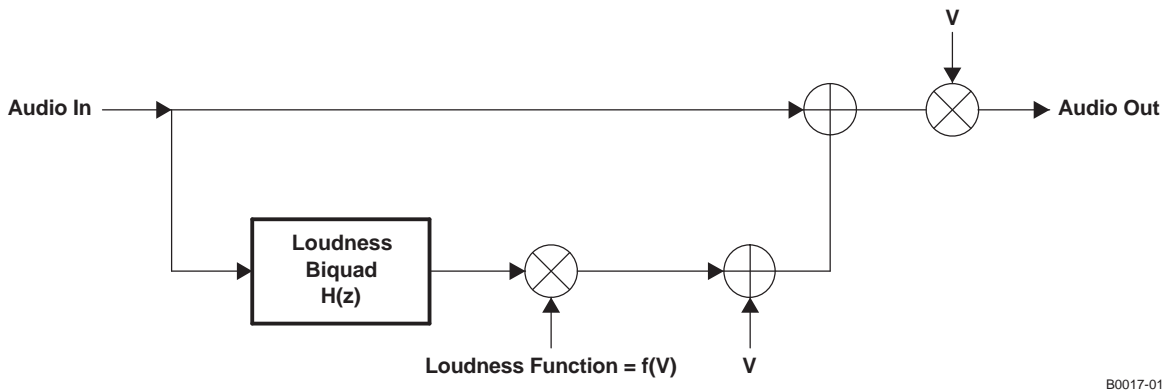

Figure 3-13. Loudness Compensation Functional Block Diagram

Loudness function =  $f(V) = G \times [2^{(\text{Log } V) \times \text{LG} + \text{LO}}] + O$  or alternatively,

Loudness function =  $f(V) = G \times [V^{\text{LG}} \times 2^{\text{LO}}] + O$

For example, for the default values  $\text{LG} = -0.5$ ,  $\text{LO} = 0$ ,  $G = 1$ , and  $O = 0$ , then:

Loudness function =  $1/\text{SQRT}(V)$ , which is the recommended transfer function for loudness. So,

Audio out = (audio in)  $\times V + H(Z) \times \text{SQRT}(V)$ . Other transfer functions are possible.

Table 3-3. Default Loudness Compensation Parameters

LOUDNESS TERM	DESCRIPTION	USAGE	DATA FORMAT	I <sup>2</sup> C SUB-ADDRESS	DEFAULT	
					HEX	FLOAT
V	Max volume	Gains audio	5.23	NA	NA	NA
Log V	$\text{Log}_2$ (max volume)	Loudness function	5.23	NA	0000 0000	0.0
H(Z)	Loudness biquad	Controls shape of loudness curves	5.23	0x95	b <sub>0</sub> = 0000 D513 b <sub>1</sub> = 0000 0000 b <sub>2</sub> = 0FFF 2AED a <sub>1</sub> = 00FE 5045 a <sub>2</sub> = 0F81 AA27	b <sub>0</sub> = 0.006503 b <sub>1</sub> = 0 b <sub>2</sub> = -0.006503 a <sub>1</sub> = 1.986825 a <sub>2</sub> = -0.986995
LG	Gain (log space)	Loudness function	5.23	0x91	FFC0 0000	-0.5
LO	Offset (log space)	Loudness function	9.23	0x92	0000 0000	0
G	Gain	Switch to enable loudness (ON = 1, OFF = 0)	5.23	0x93	0000 0000	0
O	Offset	Provides offset	9.23	0x94	0000 0000	0

### 3.7.1 Loudness Example

Problem: Due to the Fletcher-Munson phenomena, compensation for low-frequency attenuation near 60 Hz is desirable. The TAS5558 provides a loudness transfer function with EQ gain = 6, EQ center frequency = 60 Hz, and EQ bandwidth = 60 Hz.

Solution: Using Texas Instruments TAS5558 GUI tool (downloadable from ti.com) , Matlab™, or other signal-processing tool, develop a loudness function with the parameters listed in Table 3-4.

**Table 3-4. Example Loudness Function Parameters**

LOUDNESS TERM	DESCRIPTION	USAGE	DATA FORMAT	I <sup>2</sup> C SUB-ADDRESS	EXAMPLE	
					HEX	FLOAT
H(Z)	Loudness biquad	Controls shape of loudness curves	5.23	0x95	b <sub>0</sub> = 0000 8ACE b <sub>1</sub> = 0000 0000 b <sub>2</sub> = FFFF 7532 a <sub>1</sub> = FF01 1951 a <sub>2</sub> = 007E E914	b <sub>0</sub> = 0.004236 b <sub>1</sub> = 0 b <sub>2</sub> = -0.004236 a <sub>1</sub> = -1.991415 a <sub>2</sub> = 0.991488
LG	Loudness gain	Loudness function	5.23	0x91	FFC0 0000	-0.5
LO	Loudness offset	Loudness function	9.23	0x92	0000 0000	0
G	Gain	Switch to enable loudness (ON = 1, OFF = 0)	5.23	0x93	0080 0000	1
O	Offset	Offset	9.23	0x94	0000 0000	0

See [Figure 3-14](#) for the resulting loudness function at different gains.

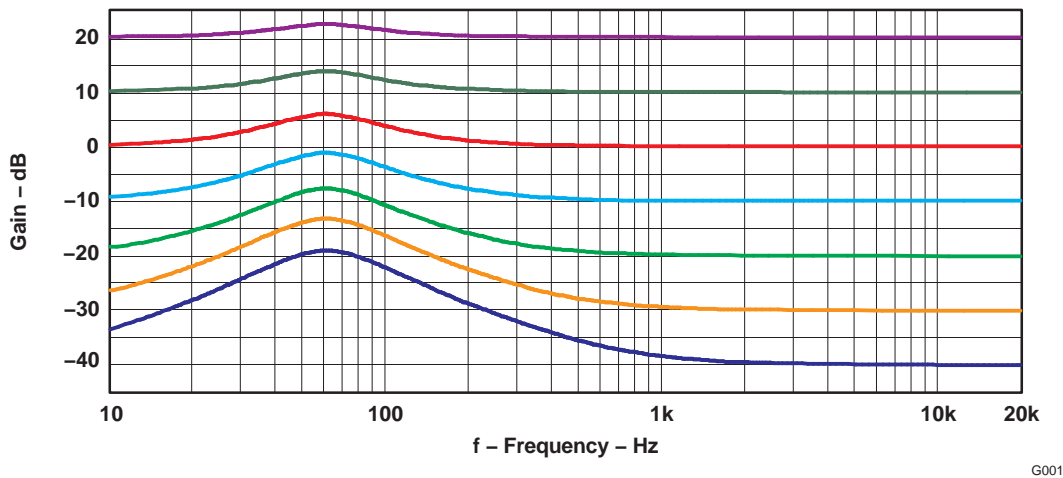

**Figure 3-14. Loudness Example Plots**

### 3.8 Dynamic Range Control (DRC)

DRC provides both compression and expansion capabilities over three separate and definable regions of audio signal levels. Programmable threshold levels set the boundaries of the three regions. Within each of the three regions, a distinct compression or expansion transfer function can be established and the slope of each transfer function is determined by programmable parameters. The offset (boost or cut) at the two boundaries defining the three regions can also be set by programmable offset coefficients. The DRC implements the composite transfer function by computing a 5.23-format gain coefficient from each sample output from the rms estimator. This gain coefficient is then applied to a mixer element, whose other input is the audio data stream. The mixer output is the DRC-adjusted audio data.

The TAS5558 has two distinct DRC blocks. DRC1 services channels 1–7 in the 8-channel mode and channels 1–4 and 7 in the 6-channel mode. This DRC computes rms estimates of the audio data streams on all channels that it controls. The estimates are then compared on a sample-by-sample basis and the larger of the estimates is used to compute the compression/expansion gain coefficient. The gain coefficient is then applied to the appropriate channel audio streams. DRC2 services only channel 8. This DRC also computes an rms estimate of the signal level on channel 8 and this estimate is used to compute the compression/expansion gain coefficient applied to the channel-8 audio stream.



All of the TAS5558 default values for DRC can be used except for the DRC1 decay and DRC2 decay. Table 3-5 shows the recommended time constants and their hex values. If the user wants to implement other DRC functions, Texas Instruments recommends using the GUI available from Texas Instruments. The tool allows the user to select the DRC transfer function graphically. It then outputs the TAS5558 hex coefficients for download to the TAS5558.

**Table 3-5. DRC Recommended Changes From TAS5558 Defaults**

I <sup>2</sup> C SUBADDRESS	REGISTER FIELDS	RECOMMENDED TIME CONSTANT (ms)	RECOMMENDED HEX VALUE	DEFAULT HEX	DEFAULT TIME CONSTANT (ms)
0x98	DRC1 energy	5	0000 883F	0000 883F	
	DRC1 (1 – energy)		007F 77C0	007F 77C0	
0x9C	DRC1 attack	5	0000 883F	0000 883F	
	DRC1 (1 – attack)		007F 77C0	007F 77C0	
	DRC1 decay	2	0001 538F	0000 0056	
0x9D	DRC2 energy	5	0000 883F	0000 883F	
	DRC2 (1 – energy)		007F 77C0	007F 77C0	
0xA1	DRC2 attack	5	0000 883F	0000 883F	
	DRC2 (1 – attack)		007F 77C0	007F 77C0	
	DRC2 decay	2	0001 538F	0000 0056	
	DRC2 (1 – decay)		007E AC70	003F FFA8	

Recommended DRC setup flow if the defaults are used:

- After power up, load the recommended hex value for DRC1 and DRC2 decay and (1 – decay). See Table 3-5.
- Enable either the pre-volume or post-volume DRC using I<sup>2</sup>C registers 0x96 and 0x97. Note that to avoid a potential timing problem, there is a 10-ms delay between a write to 0x96 and a write to 0x97.

Recommended DRC setup flow if the DRC design uses values different from the defaults:

- After power up, load all DRC coefficients per the DRC design.
- Enable either the pre-volume or post-volume DRC. Note that to avoid a potential timing problem, there is a 10-ms delay between a write to 0x96 and a write to 0x97.

Figure 3-15 shows the positioning of the DRC block in the TAS5558 processing flow. As seen, the DRC input can come either before or after soft volume control and loudness processing.

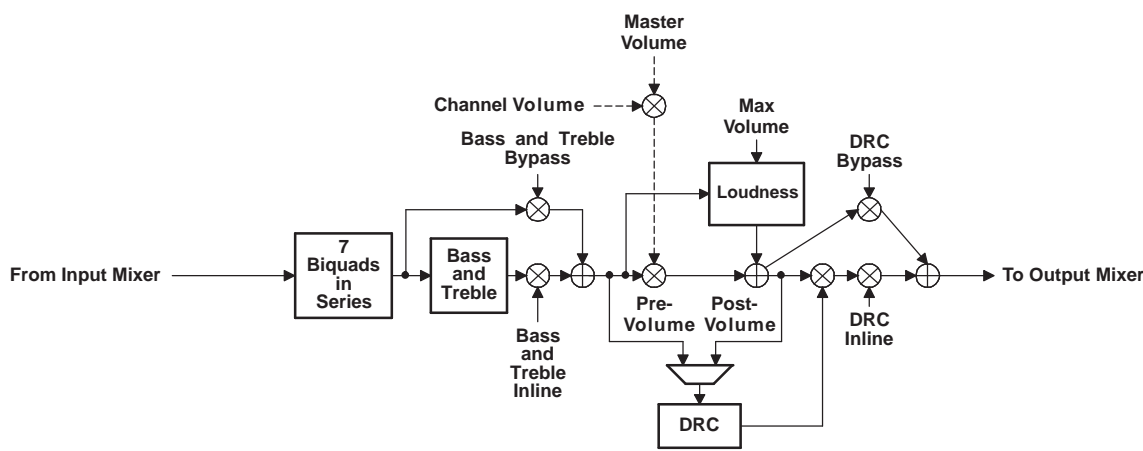

**Figure 3-15. DRC Positioning in TAS5558 Processing Flow**

B0016-02

Figure 3-16 illustrates a typical DRC transfer function.

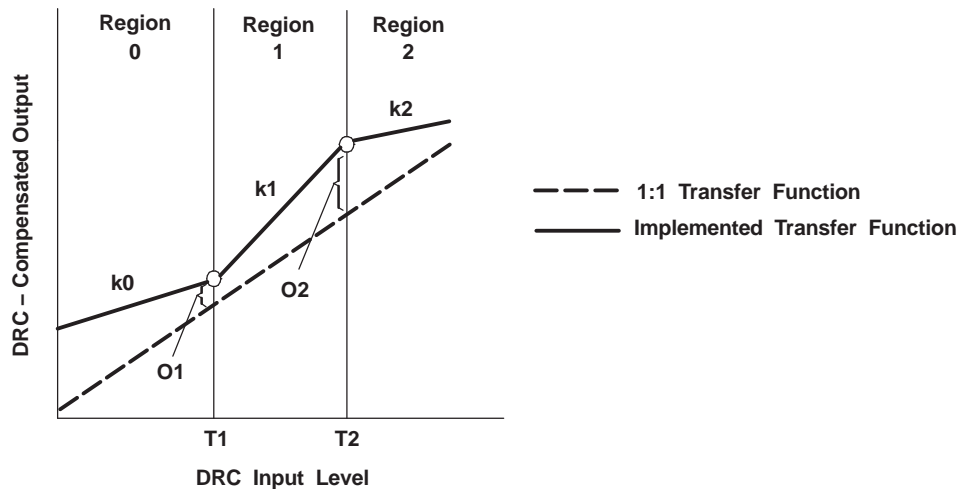

M0014-01

**Figure 3-16. Dynamic Range Compression (DRC) Transfer Function Structure**

The three regions shown in Figure 3-16 are defined by three sets of programmable coefficients:

- Thresholds  $T_1$  and  $T_2$  define region boundaries.
- Offsets  $O_1$  and  $O_2$  define the DRC gain coefficient settings at thresholds  $T_1$  and  $T_2$ , respectively.
- Slopes  $k_0$ ,  $k_1$ , and  $k_2$  define whether compression or expansion is to be performed within a given region. The magnitudes of the slopes define the degree of compression or expansion to be performed.

The three sets of parameters are all defined in logarithmic space and adhere to the following rules:

- The maximum input sample into the DRC is referenced at 0 dB. All values below this maximum value then have negative values in logarithmic (dB) space.
- Thresholds  $T_1$  and  $T_2$  define, in dB, the boundaries of the three regions of the DRC, as referenced to the rms value of the data into the DRC. Zero-valued threshold settings reference the maximum-valued rms input into the DRC and negative-valued thresholds reference all other rms input levels. Positive-valued thresholds have no physical meaning and are not allowed. In addition, zero-valued threshold settings are not allowed.

#### CAUTION

**Zero-valued and positive-valued threshold settings are not allowed and cause unpredictable behavior if used.**

- Offsets  $O_1$  and  $O_2$  define, in dB, the attenuation (cut) or gain (boost) applied by the DRC-derived gain coefficient at the threshold points  $T_1$  and  $T_2$ , respectively. Positive offsets are defined as cuts, and thus boost or gain selections are negative numbers. Offsets must be programmed as 32-bit (9.23 format) numbers.
- Slopes  $k_0$ ,  $k_1$ , and  $k_2$  define whether compression or expansion is to be performed within a given region, and the degree of compression or expansion to be applied. Slopes are programmed as 28-bit (5.23 format) numbers.

### 3.8.1 DRC Implementation

The three elements comprising the DRC include: (1) an rms estimator, (2) a compression/expansion coefficient computation engine, and (3) an attack/decay controller.

- **RMS estimator**—This DRC element derives an estimate of the rms value of the audio data stream into the DRC. For the DRC block shared by Ch1 and Ch2, two estimates are computed—an estimate of the Ch1 audio data stream into the DRC, and an estimate of the Ch2 audio data stream into the DRC. The outputs of the two estimators are then compared, sample-by-sample, and the larger-valued sample is forwarded to the compression/expansion coefficient computation engine. Two programmable parameters, *ae* and  $(1 - ae)$ , set the effective time window over which the rms estimate is made. For the DRC block shared by Ch1 and Ch2, the programmable parameters apply to both rms estimators. The time window over which the rms estimation is computed can be determined by:

$$t_{\text{window}} = \frac{-1}{f_s \ln(1 - ae)}$$

- Care should be taken when calculating the time window for 192kHz content. Please use 96kHz as the sampling frequency for 96kHz AND 192kHz, as the TAS5558 uses a digital decimator to do all DAP processing at 96kHz.
  - ae* = energy time (1)
- **Compression/expansion coefficient computation**—This DRC element converts the output of the rms estimator to a logarithmic number, determines the region where the input resides, and then computes and outputs the appropriate coefficient to the attack/decay element. Seven programmable parameters, *T1*, *T2*, *O1*, *O2*, *k0*, *k1*, and *k2*, define the three compression/expansion regions implemented by this element.
  - **Attack/decay control**—This DRC element controls the transition time of changes in the coefficient computed in the compression/expansion coefficient computation element. Four programmable parameters define the operation of this element. Parameters *ad* and  $(1 - ad)$  set the decay or release time constant to be used for volume boost (expansion). Parameters *aa* and  $(1 - aa)$  set the attack time constant to be used for volume cuts. The transition time constants can be determined by:

$$t_a = \frac{-1}{f_s \ln(1 - aa)} \qquad t_d = \frac{-1}{f_s \ln(1 - ad)}$$

- aa* = attack time
- ad* = decay time (2)

### 3.8.2 Compression/Expansion Coefficient Computation Engine Parameters

Seven programmable parameters are assigned to each DRC block: two threshold parameters—*T1* and *T2*, two offset parameters—*O1* and *O2*, and three slope parameters—*k0*, *k1*, and *k2*. The threshold parameters establish the three regions of the DRC transfer curve, the offsets anchor the transfer curve by establishing known gain settings at the threshold levels, and the slope parameters define whether a given region is a compression or an expansion region.

*T2* establishes the boundary between the high-volume region and the mid-volume region. *T1* establishes the boundary between the mid-volume region and the low-volume region. Both thresholds are set in logarithmic space, and which region is active for any given rms estimator output sample is determined by the logarithmic value of the sample.

Threshold *T2* serves as the fulcrum or pivot point in the DRC transfer function. *O2* defines the boost (> 0 dB) or cut (< 0 dB) implemented by the DRC-derived gain coefficient for an rms input level of *T2*. If *O2* = 0 dB, the value of the derived gain coefficient is 1 (0x0080 0000 in 5.23 format). *k2* is the slope of the DRC transfer function for rms input levels above *T2*, and *k1* is the slope of the DRC transfer function for rms input levels below *T2* (and above *T1*). The labeling of *T2* as the fulcrum stems from the fact that there cannot be a discontinuity in the transfer function at *T2*. The user can, however, set the DRC parameters to realize a discontinuity in the transfer function at the boundary defined by *T1*. If no discontinuity is desired at *T1*, the value for the offset term *O1* must obey the following equation.

$$O1_{\text{No Discontinuity}} = |T1 - T2| \times k1 + O2 \quad \text{For } (|T1| \geq |T2|)$$

T1 and T2 are the threshold settings in dB, k1 is the slope for region 1, and O2 is the offset in dB at T2. If the user chooses to select a value of O1 that does not obey the above equation, a discontinuity at T1 is realized.

Decreasing in volume from T2, the slope k1 remains in effect until the input level T1 is reached. If, at this input level, the offset of the transfer function curve from the 1 : 1 transfer curve does not equal O1, there is a discontinuity at this input level as the transfer function is snapped to the offset called for by O1. If no discontinuity is wanted, O1 and/or k1 must be adjusted so that the value of the transfer curve at input level T1 is offset from the 1 : 1 transfer curve by the value O1. The examples that follow illustrate both continuous and discontinuous transfer curves at T1.

Decreasing in volume from T1, starting at offset level O1, slope k0 defines the compression/expansion activity in the lower region of the DRC transfer curve.

### 3.8.2.1 Threshold Parameter Computation

For thresholds,

$$T_{dB} = -6.0206T_{INPUT} = -6.0206T_{SUB\_ADDRESS\_ENTRY}$$

If, for example, it is desired to set T1 = -64 dB, then the subaddress entry required to set T1 to -64 dB is:

$$T1_{SUB\_ADDRESS\_ENTRY} = \frac{-64}{-6.0206} = 10.63$$

T1 is entered as a 32-bit number in 9.23 format. Therefore:

$$\begin{aligned} T1 = 10.63 &= 0\ 1010.1010\ 0001\ 0100\ 0111\ 1010\ 111 \\ &= 0x0550\ A3D7\ \text{in 9.23 format} \end{aligned}$$

### 3.8.2.2 Offset Parameter Computation

The offsets set the boost or cut applied by the DRC-derived gain coefficient at the threshold point. An equivalent statement is that offsets represent the departure of the actual transfer function from a 1 : 1 transfer at the threshold point. Offsets are 9.23 Formatted, 32bit logarithmic numbers. They are computed by the following equation:

$$O_{INPUT} = \frac{O_{DESIRED} + 24.0824\ \text{dB}}{6.0206}$$

Gains or boosts are represented as negative numbers; cuts or attenuations are represented as positive numbers. For example, to achieve a boost of 21 dB at threshold T1, the I<sup>2</sup>C coefficient value entered for O1 must be:

$$\begin{aligned} O1_{INPUT} &= \frac{-21\ \text{dB} + 24.0824\ \text{dB}}{6.0206} = 0.5119755 \\ &= 0.1000\_0011\_0001\_1101\_0100 \\ &= 0x0041886A\ \text{in 9.23 format} \end{aligned}$$

### 3.8.2.3 Slope Parameter Computation

In developing the equations used to determine the subaddress of the input value required to realize a given compression or expansion within a given region of the DRC, the following convention is adopted.

$$\text{DRC transfer} = \text{Input increase} : \text{Output increase}$$

If the DRC realizes an output increase of n dB for every dB increase in the rms value of the audio into the DRC, a 1 : n expansion is being performed. If the DRC realizes a 1-dB increase in output level for every n-dB increase in the rms value of the audio into the DRC, an n : 1 compression is being performed.

$$k = n - 1$$

For n : 1 compression, the slope k can be found by:  $k = \frac{1}{n} - 1$

In both expansion (1 : n) and compression (n : 1), n is implied to be greater than 1. Thus, for expansion:

$k = n - 1$  means  $k > 0$  for  $n > 1$ . Likewise, for compression,  $k = \frac{1}{n} - 1$  means  $-1 < k < 0$  for  $n > 1$ . Thus, it appears that k must always lie in the range  $k > -1$ .

The DRC imposes no such restriction and k can be programmed to values as negative as -15.999. To determine what results when such values of k are entered, it is first helpful to note that the compression and expansion equations for k are actually the same equation. For example, a 1 : 2 expansion is also a 0.5 : 1 compression.

$$0.5 : 1 \text{ compression} \Rightarrow k = \frac{1}{0.5} - 1 = 1$$

$$1 : 2 \text{ expansion} \Rightarrow k = 2 - 1 = 1$$

As can be seen, the same value for k is obtained either way. The ability to choose values of k less than -1 allows the DRC to implement negative-slope transfer curves within a given region. Negative-slope transfer curves are usually not associated with compression and expansion operations, but the definition of these operations can be expanded to include negative-slope transfer functions. For example, if  $k = -4$

$$\text{Compression equation: } k = -4 = \frac{1}{n} - 1 \Rightarrow n = -\frac{1}{3} \Rightarrow -0.3333 : 1 \text{ compression}$$

$$\text{Expansion equation: } k = -4 = n - 1 \Rightarrow n = -3 \Rightarrow 1 : -3 \text{ expansion}$$

With  $k = -4$ , the output decreases 3 dB for every 1 dB increase in the rms value of the audio into the DRC. As the input increases in volume, the output decreases in volume.

### 3.9 THD Manager

The THD manager is designed to set the max output level target after all processing has been completed. The Audio clip engages at +24dB between (pre) and (post) stage. 10% distortion occurs when audio is clipping approx +2.4 to 3dB over full scale. There is amplitude loss when clipping, so THD(post) might allow slight gain through THD manager. 10% distortion clipping will account for approx -1dB of output level loss. This is accounted for as seen with +1dB in step 2 to set output level +0dB

Example setup to modify 10% THD output level: \* note that coefficient calculations are approximate for simplicity

1. Signal path settings
  - Input -10dBFS
  - Volume 0xD9 0000 000C +15dB
  - THD Manager (pre) 0xE9 0650 0000 +22dB
  - THD Manager (post) 0xEA 0006 7000 -26dB
2. resulting output
  - output clipping at 10% distortion with output level +0dB
  - input -10 vol +15 THD(pre) +22 THD(post) -26
  - -10 +5 +27(clip) +1
3. Begin clipping at -12dBFS input with +0dB output level
  - THD Manager (pre) 0xE9 07FF FFFF +24dB (previous setting +22dB + 2dB)
  - result: input -12dBFS output clipping at 10% distortion with output level +0dB
  - input -12 vol +15 THD(pre) +24 THD(post) -26
  - -12 +3 +27(clip) +1
4. Begin clipping at -12dBFS input with -10dB output
  - THD Manager (post) 0xEA 0002 0000 -36dB (previous setting -26dB -10dB)
  - result: input -12dBFS output clipping at 10% distortion with output level +0dB
  - input -12 vol +15 THD(pre) +24 THD(post) -36

- -12 +3 +27(clip) -9

### 3.10 Downmix Algorithm and I2S Out

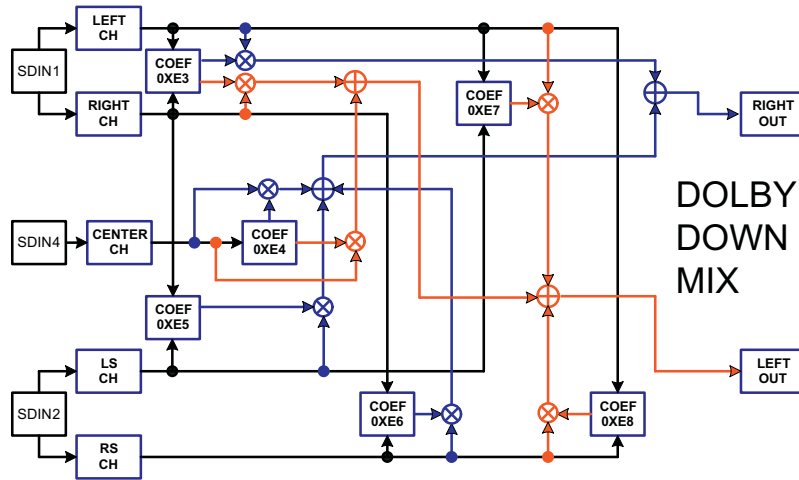

Figure 3-17. Dolby Downmix

The TAS5558 has an excellent feature that can mix the input signals to create a downmix to make the I2S serial output which has an SRC that keeps output sample rate at 48KHz irrespective of input sample rate.

Downmix registers are defined as follows:

- 0xE3 == Coefficient for L and R channels
- 0xE4 == Coefficient for Center channel
- 0xE5 == Coefficient for LS for R\_out
- 0xE6 == Coefficient for Rs for R\_out
- 0xE7 == Coefficient for Ls for L\_out
- 0xE8 == Coefficient for Rs for L\_out

$$L\_out = E3 \times L + E4 \times C + E7 \times Ls + E8 \times Rs$$

$$R\_out = E3 \times R + E4 \times C + E5 \times Ls + E6 \times Rs$$

L, R, C, Ls, Rs are input cross bar mixer outputs. L, R, C, Ls, Rs are defined as the output of input mixers. L = Ch1, R = Ch2, C = Ch8, Ls = Ch3, Rs = Ch4, use input mixer to mix any other channels to I2S Out. (3)

Input Mixers also can be used as other mixers to mix subwoofer channels to I<sup>2</sup>S out.

By default I<sup>2</sup>S out has the following values:

$$L\_out = \frac{(L + 0.707 \times C - 0.707 \times Ls - 0.707 \times Rs)}{3.121}$$

$$R\_out = \frac{(R + 0.707 \times C - 0.707 \times Ls - 0.707 \times Rs)}{3.121}$$

(4)

### 3.11 Stereo Downmixes/(or Fold-Downs)

#### 3.11.1 Left Total/Right Total (Lt/Rt)

Lt/Rt is a downmix suitable for decoding with a Dolby Pro Logic upmixer to obtain 5.1 channels again. Lt/Rt is also suitable for stereophonic sound playback on a hi-fi or on headphones.

$$Lt = L + -3dB \times C + -3dB \times (-Ls - Rs)$$

$$Rt = R + -3dB \times C + -3dB \times (Ls + Rs)$$

where Ls and Rs are phase shifted 90°

(5)

#### 3.11.2 Left Only/Right Only (Lo/Ro)

Lo/Ro is a downmix suitable when mono compatibility is required. Lo/Ro destroys front/rear channel separation information and thus a Dolby Pro Logic upmixer will not be able to properly extract 5.1 channels again.

$$Lo = L + -3dB \times C + att \times Ls$$

$$Ro = R + -3dB \times C + att \times Rs$$

where att = -3 dB, -6 dB, -9 dB or 0 dB

(6)

### 3.12 Output Mixer

The TAS5558 provides an 8x2 output mixer for channels 1, 2, 3, 4, 5, and 6. For channels 7 and 8, the TAS5558 provides an 8x3 output mixer. These mixers allow each output to be any mix of any two (or three) signal-processed channels. The control parameters for the output crossbar mixer are programmable via the I<sup>2</sup>C interface. All of the TAS5558 features are available when the 8x2 and 8x3 output mixers are configured in the pass-through output mixer configuration, where the audio data from each DAP channel maps directly to the corresponding PWM channel (that is, DAP channel 1 to PWM channel 1, and so on).

When mixing or remapping DAP channels to different PWM output channels there are limitations to consider:

- Individual channel mute should not be used.
- The sum of the minimum channel volume and master volume should not be below -109 dB.

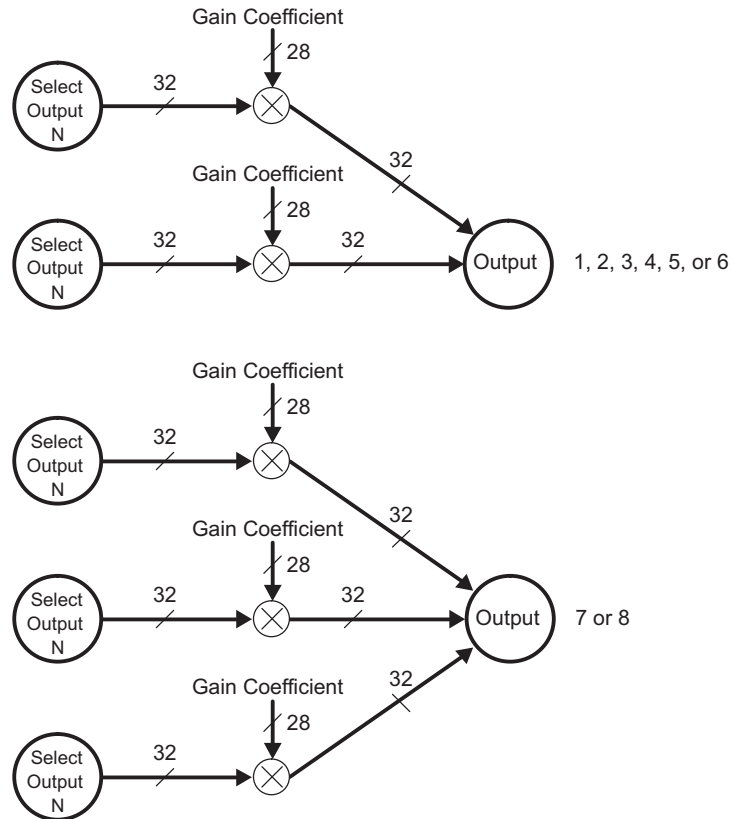

M0011-05

**Figure 3-18. Output Mixers**



## 4 PWM

### 4.1 PWM Features

The TAS5558 has eight channels of high-performance digital PWM modulators that are designed to drive switching output stages (back ends) in both single-ended (SE) and bridge-tied-load (BTL) configurations. The device uses noise-shaping and sophisticated, error-correction algorithms to achieve high power efficiency and high-performance digital audio reproduction. The TAS5558 uses an AD/BD/Ternary PWM modulation scheme combined with a fourth-order noise shaper to provide a >105-dB SNR from 20 Hz to 20 kHz.

The PWM section accepts 32-bit PCM data from the DAP and outputs eight PWM audio output channels configurable as either:

- Six channels to drive power stages and two channels to drive a differential-input active filter to provide a separately controllable stereo lineout
- Eight channels to drive power stages

The PWM section provides a headphone PWM output to drive an external differential amplifier like the TPA6139A2. The headphone circuit uses the PWM modulator for channels 1 and 2. The headphone does not operate while the six or eight back-end drive channels are operating. The headphone is enabled via a headphone-select terminal.

The PWM section also contains the power-supply volume control (PSVC) PWM.

The interpolator, noise shaper, and PWM sections provide a PWM output with the following features:

- Up to 8x oversampling
  - 4x at  $f_s = 88.2$  kHz, 96 kHz
  - 2x at  $f_s = 176.4$  kHz, 192 kHz
- Fourth-order noise shaping
- 105-dB dynamic range 0–20 kHz (TAS5558 + TAS5614 system measured at speaker terminals)
- THD < 0.01%
- Adjustable modulation limit of 87.4% to 99.2%
- 3.3-V digital signal

#### 4.1.1 DC Blocking (High-Pass Filter Enable/Disable)

Each input channel incorporates a first-order, digital, high-pass filter to block potential dc components. The filter –3-dB point is approximately 2-Hz at the 96-kHz sampling rate. The high-pass filter can be enabled and disabled via the I<sup>2</sup>C system control register 1 (0x03 bit D7). The default setting is 1 (high-pass filter enabled).

#### 4.1.2 AM Interference Avoidance

Digital amplifiers can degrade AM reception as a result of their RF emissions. Texas Instruments' patented AM interference-avoidance circuit provides a flexible system solution for a wide variety of digital audio architectures. During AM reception, the TAS5558 adjusts the radiated emissions to provide an emission-clear zone for the tuned AM frequency. The inputs to the TAS5558 for this operation are the tuned AM frequency, the IF frequency, and the sample rate. This PWM rate modification is done by modifying the output rate of the Sample Rate Converter, and the following DSP and PWM modulator.

## 5 TAS5558 Controls and Status

The TAS5558 provides control and status information from both the I<sup>2</sup>C registers and device pins.

This section describes some of these controls and status functions. The I<sup>2</sup>C summary and detailed register descriptions are contained in [Section 10](#) and [Section 11](#).

### 5.1 I<sup>2</sup>C Status Registers

The TAS5558 has two status registers that provide general device information. These are the general status register 0 (0x01) and the error status register (0x02).

#### 5.1.1 General Status Register (0x01)

- Device identification code

#### 5.1.2 Error Status Register (0x02)

- No internal errors (the valid signal is high)
- Audio Clip indicator. Writing to the register clears the indicator.
- A clock error has occurred – These are sticky bits that are cleared by writing '00' to the register.
  - Frame slip – when the number of MCLKs per LRCLK changes by more than 10 MCLK cycles
- This error status register is normally used for system development only.

### 5.2 TAS5558 Pin Controls

The TAS5558 provide a number of terminal controls to manage the device operation. These controls are:

- $\overline{\text{RESET}}$
- $\overline{\text{PDN}}$
- $\overline{\text{BKND\_ERR}}$
- $\overline{\text{HP\_SEL}}$
- $\overline{\text{MUTE}}$
- PSVC
- EMO1 (see [System Power Controller](#) section)
- EMO2 (see [System Power Controller](#) section)

#### 5.2.1 Reset ( $\overline{\text{RESET}}$ )

The TAS5558 is placed in the reset mode either by the power-up reset circuitry when power is applied, or by setting the  $\overline{\text{RESET}}$  terminal low.

$\overline{\text{RESET}}$  is an asynchronous control signal that restores the TAS5558 to the hard-mute state (Non PWM Switching). Master volume is immediately set to full attenuation (there is no ramp down). Reset initiates the device reset without an MCLK input. As long as the  $\overline{\text{RESET}}$  terminal is held low, the device is in the reset state. During reset, all I<sup>2</sup>C and serial data bus operations are ignored.

[Table 5-1](#) shows the device output signals while  $\overline{\text{RESET}}$  is active.

**Table 5-1. Device Outputs During Reset**

SIGNAL	SIGNAL STATE
Valid	Low
PWM P-outputs	Low (Non PWM Switching)
PWM M-outputs	Low (Non PWM Switching)
SDA	Signal input (not driven)

Because  $\overline{\text{RESET}}$  is an asynchronous signal, clicks and pops produced during the application (the leading edge) of  $\overline{\text{RESET}}$  cannot be avoided. However, the transition from the hard-mute state (Non PWM Switching) to the operational state is performed using a quiet start-up sequence to minimize noise. This control uses the PWM reset and unmute sequence to shut down and start up the PWM. If a completely quiet reset or power-down sequence is desired,  $\overline{\text{MUTE}}$  should be applied before applying  $\overline{\text{RESET}}$ .

The rising edge of the reset pulse begins device initialization before the transition to the operational mode. During device initialization, all controls are reset to their initial states. [Table 5-2](#) shows the default control settings following a reset.

**Table 5-2. Values Set During Reset**

CONTROL	SETTING
Output mixer configuration	0xD0 bit 30 = 0 (remapped output mixer configuration)
High pass	Enabled
Unmute from clock error	Hard unmute
Input automute	Enabled
Output automute	Enabled
Serial data interface format	I <sup>2</sup> S, 24-bit
Individual channel mute	No channels are muted
Automute delay	14.9 ms
Automute threshold 1	< 8 bits
Automute threshold 2	Same as automute threshold 1
Modulation limit	93.7% (Note: Some power stages require a lower modulation index)
Six- or eight-channel configuration	Eight channels
Volume and mute update rate	Volume ramp 42.6 ms
Treble and bass slew rate	Update every 1.31 ms
Bank switching	Manual bank selection is enabled
Biquad coefficients	Set to all pass
Input mixer coefficients	Input N → Channel N, no attenuation
Output mixer coefficients	Channel N → Output N, no attenuation
Subwoofer sum into Ch1 and Ch2	Gain of 0
Ch1 and Ch2 sum in subwoofer	Gain of 0
Bass and treble bypass/inline	Bypass
DRC bypass/inline	Bypass
DRC	Default values
Master volume	Mute
Individual channel volumes	0 dB
All bass and treble indexes	0 dB
Treble filter sets	Filter set 3
Bass filter sets	Filter set 3
Loudness	Loudness disabled, default values
AM interference mode enable	Disabled
AM interference mode IF	455 kHz
AM interference mode select sequence	1
AM interference mode tuned frequency and input mode	0000, BCD

After the initialization time, the TAS5558 starts the transition to the operational state with the master volume set at mute.

Because the TAS5558 has an internal oscillator time base, following the release of reset, oscillator trim command is needed so the TAS5558 can detect the MCLK and data rate and perform the initialization sequences. The PWM outputs are held at a mute state until the master volume is set to a value other than mute via I<sup>2</sup>C.

### 5.2.2 Power Down ( $\overline{\text{PDN}}$ )

The TAS5558 can be placed into the power-down mode by holding the  $\overline{\text{PDN}}$  terminal low. When the power-down mode is entered, both the PLL and the oscillator are shut down. Volume is immediately set to full attenuation (there is no ramp down). This control uses the PWM mute sequence that provides a low click and pop transition to a non PWM switching mute state.

Power down is an asynchronous operation that does not require MCLK to go into the power-down state. To initiate the power-up sequence requires MCLK to be operational and the TAS5558 to receive five MCLKs prior to the release of  $\overline{\text{PDN}}$ .

As long as the  $\overline{\text{PDN}}$  pin is held low, the device is in the power-down state with the PWM outputs not switching. During power down, all I<sup>2</sup>C and serial data bus operations are ignored. [Table 5-3](#) shows the device output signals while  $\overline{\text{PDN}}$  is active.

**Table 5-3. Device Outputs During Power Down**

SIGNAL	SIGNAL STATE
VALID	Low
PWM P-outputs	Not Switching = Low
PWM M-outputs	Not Switching = Low
SDA	Inputs Ignored
PSVC	Low

Following the application of  $\overline{\text{PDN}}$ , the TAS5558 does not perform a quiet shutdown to prevent clicks and pops produced during the application (the leading edge) of this command. The application of  $\overline{\text{PDN}}$  immediately performs a PWM stop. A quiet stop sequence can be performed by first applying  $\overline{\text{MUTE}}$  before  $\overline{\text{PDN}}$ .

When  $\overline{\text{PDN}}$  is released, the system goes to the end state specified by the  $\overline{\text{MUTE}}$  and  $\overline{\text{BKND\_ERR}}$  pins and the I<sup>2</sup>C register settings.

The internal oscillator time base allows the TAS5558 to determine the data rate. Once these rates are determined, the TAS5558 unmutes the audio.

### 5.2.3 Back-End Error ( $\overline{\text{BKND\_ERR}}$ )

Back-end error is used to provide error management for back-end error conditions. Back-end error is a level-sensitive signal. Back-end error can be initiated by bringing the  $\overline{\text{BKND\_ERR}}$  terminal low for a minimum of five MCLK cycles. When  $\overline{\text{BKND\_ERR}}$  is brought low, the PWM sets either six or eight channels into the PWM back-end error state. This state is described in [Section 4.1](#). Once the back-end error is removed, a delay of 5 ms is performed before the system starts the output re-initialization sequence. After the initialization time, the TAS5558 begins normal operation. During back-end error I<sup>2</sup>C registers retain current values.

**Table 5-4. Device Outputs During Back-End Error**

SIGNAL	SIGNAL STATE
Valid	Low
PWM P-outputs	Non PWM Switching = low
PWM M-outputs	Non PWM Switching = low
PWM_HP P-outputs	Non PWM Switching = low
PWM_HP M-outputs	Non PWM Switching = low
SDA	Signal input (not driven)

#### 5.2.3.1 $\overline{\text{BKND\_ERR}}$ and VALID

The number of channels that are affected by the  $\overline{\text{BKND\_ERR}}$  signal depends on the setting of bit D1 of I<sup>2</sup>C register 0xE0. If the I<sup>2</sup>C setting (of bit D1) is 0 (8-channel mode), the TAS5558 places all eight PWM outputs in the PWM back-end error state. If the I<sup>2</sup>C setting (of bit D1) is 1, the TAS5558 is in 6-channel mode. For proper operation in 6-channel mode, the lineout configuration registers (0x09 and 0x0A) must be 0x00 instead of the default of 0xE0. In this case, VALID is pulled LOW, and the TAS5558 brings PWM outputs 1, 2, 3, 4, 7, and 8 to a back-end error state, while not affecting lineout channels 5 and 6. [Table 5-4](#) shows the device output signal states during back-end error.

### 5.2.4 Speaker/Headphone Selector ( $\overline{HP\_SEL}$ )

The  $\overline{HP\_SEL}$  terminal enables the headphone output or the speaker outputs. The headphone output receives the processed data output from DAP and PWM channels 1 and 2.

In 6-channel configuration, this feature does not affect the two lineout channels.

When low, the headphone output is enabled. In this mode, the speaker outputs are disabled. When high, the speaker outputs are enabled and the headphone is disabled.

Changes in the pin logic level result in a state change sequence using soft mute (PWM switching at 50/50, noise shaper on) to the hard mute (non-PWM switching) mode for both speaker and headphone followed by a soft unmute.

When  $\overline{HP\_SEL}$  is low, the configuration of channels 1 and 2 is defined by the headphone configuration register. When  $\overline{HP\_SEL}$  is high, the channel-1 and -2 configuration registers define the configuration of channels 1 and 2.

If using the remapped-output mixer configuration (0xD0 bit 30 = 0) in the 6-channel mode, the headphone operation is modified. That is, following the assertion or de-assertion of headphone, mute must be asserted and de-asserted using the  $\overline{MUTE}$  pin.

### 5.2.5 Mute ( $\overline{MUTE}$ )

The mute control provides a noiseless volume ramp to silence. Releasing mute provides a noiseless ramp to previous volume. The TAS5558 has both master and individual channel mute commands. A terminal is also provided for the master mute. The master mute I<sup>2</sup>C register and the  $\overline{MUTE}$  terminal are logically ORed together. If either is asserted, a mute on all channels is performed. The master mute command operates on all channels regardless of whether the system is in the 6- or 8-channel configuration. PWM is switching at 50% duty cycle during mute.

The master mute terminal is used to support a variety of other operations in the TAS5558, such as setting the biquad coefficients, the serial interface format, and the clock rates. A mute command by the master mute terminal, individual I<sup>2</sup>C mute, the AM interference mute sequence, the bank-switch mute sequence, or automute overrides an unmute command or a volume command. While a mute is active, the commanded channels are placed in a mute state. When a channel is unmuted, it goes to the last commanded volume setting that has been received for that channel.

### 5.2.6 Power-Supply Volume Control (PSVC)

The TAS5558 supports volume control both by conventional digital gain/attenuation and by a combination of digital and analog gain/attenuation. Varying the H-bridge power-supply voltage performs the analog volume control function. The benefits of using power-supply volume control (PSVC) are reduced idle channel noise, improved signal resolution at low volumes, increased dynamic range, and reduced radio frequency emissions at reduced power levels. The PSVC is enabled via I<sup>2</sup>C. When enabled, the PSVC provides a PWM output that is filtered to provide a reference voltage for the power supply. The power-supply adjustment range can be set for  $-12.04$ ,  $-18.06$ , or  $-24.08$  dB, to accommodate a range of variable power-supply designs.

Figure 5-1 and Figure 5-2 show how power-supply and digital gains can be used together.

The volume biquad (0xCF) can be used to implement a low-pass filter in the digital volume control to match the PSVC volume transfer function. Note that if the PVSC function is not used, the volume biquad is all-pass (default).

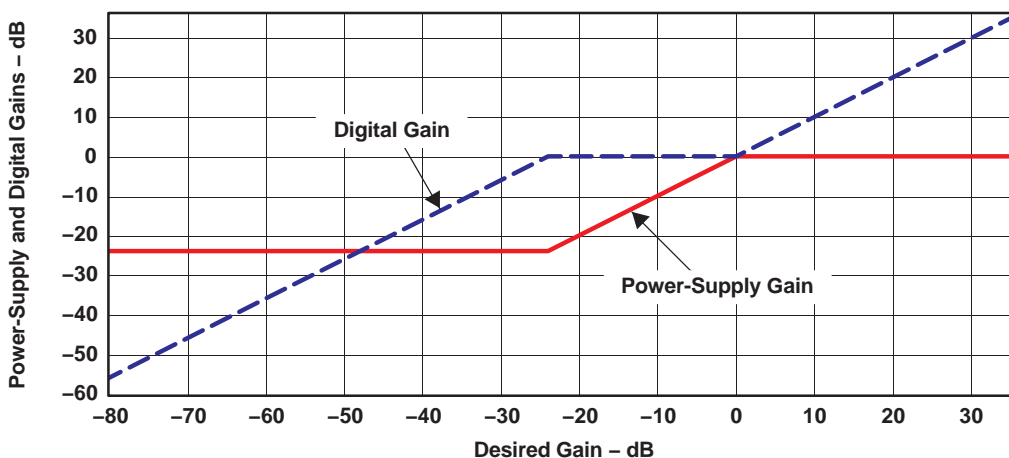

G002

Figure 5-1. Power-Supply and Digital Gains (Linear Space)

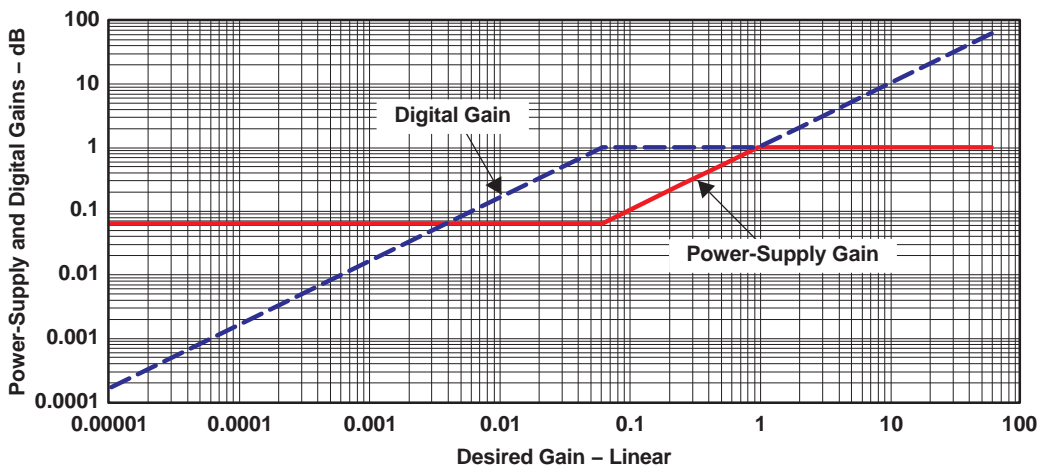

G003

Figure 5-2. Power-Supply and Digital Gains (Log Space)

### 5.3 Device Configuration Controls

The TAS5558 provides a number of system configuration controls that can be set at initialization and set following a reset.

- Channel configuration
- Headphone configuration
- Audio system configurations
- Recovery from clock error
- Power-supply volume-control enable
- Volume and mute update rate
- Modulation index limit
- Master-clock and data-rate controls
- Bank controls

#### 5.3.1 Channel Configuration

These registers control the TAS5558 response to back end errors.

**Table 5-5. Description of the Channel Configuration Registers (0x05 to 0x0C)**

BIT	DESCRIPTION
D7	Enable/disable error recovery sequence. In case the $\overline{\text{BKND\_ERR}}$ pin is pulled low, this register determines if this channel is to follow the error recovery sequence or to continue with no interruption.
D6	Determines if the power stage needs the TAS5558 VALID pin to go low to reset the power stage. Some power stages can be reset by a combination of PWM signals. For these devices, it is recommended to set this bit low, because the VALID pin is shared for power stages. This provides better control of each power stage.
D5	Determines if the power stage needs the TAS5558 VALID pin to go low to mute the power stage. Some power stages can be muted by a combination of PWM signals. For these devices, it is recommended to set this bit low, because the VALID pin is shared for power stages. This provides better control of each power stage.
D4	Inverts the PWM output. Inverting the PWM output can be an advantage if the power stage input pin is opposite the TAS5558 PWM pinout. This makes routing on the PCB easier. To keep the phase of the output, the speaker terminals must also be inverted.
D3	When using the TI Power Stage this bit must be set. (Specifically for the TAS5182)
D2	Can be used to handle click and pop for some applications.
D1	This bit is normally used together with D2. For some power stages, both PWM signals must be high to get the desired operation of both speaker outputs to be low. This bit sets the PWM outputs high-high during mute.
D0	Not used

#### 5.3.2 Headphone Configuration Registers

The headphone configuration controls are identical to the speaker configuration controls. The headphone configuration control settings are used in place of the speaker configuration control settings for channels 1 and 2 when the headphones are selected. However, only one configuration setting for headphones is used, and it is the default setting, that is, in headphone mode 0x05 and 0x06 settings are fixed in default.

#### 5.3.3 Audio System Configurations

The TAS5558 can be configured to comply with various audio systems: 5.1-channel system, 6-channel system, 7.1-channel system, and 8-channel system.

The audio system configuration is set in the general control register (0xE0). Bits D31–D4 must be zero and D0 is *do not care*.

- D3 Must always be 0 (default). Note that subwoofer cannot be used as lineout when PSVC is enabled. (D3 is a write-only bit)
- D2 Enables/disables power-supply volume control



D1 Sets number of speakers in the system, including possible line outputs

D3–D1 must be configured for the audio system in the application, as shown in [Table 5-6](#).

**Table 5-6. Audio System Configuration (General Control Register 0xE0)**

Audio System	D31–D4	D3	D2	D1	D0
6 channels or 5.1 not using PSVC	0	0	0	1	X
6 channels using PSVC	0	0	1	1	X
5.1 system using PSVC	0	0	1	1	X
<b>8 channels or 7.1 not using PSVC (default)</b>	<b>0</b>	<b>0</b>	<b>0</b>	<b>0</b>	<b>X</b>
8 channels using PSVC	0	0	1	0	X
7.1 system using PSVC	0	0	1	0	X

### 5.3.3.1 Using Line Outputs in 6-Channel Configurations

The audio system can be configured for a 6-channel configuration (with 2 lineouts) by writing a 1 to bit D1 of register 0xE0 (general control register). In this configuration, channel-5 and -6 processing are exactly the same as the other channels, except that the master volume and the loudness function have no effect on the signal.

Note that in 6-channel configuration, channels 5 and 6 are unaffected by back-end error (`BKND_ERR` goes low).

To use channels 5 and 6 as unprocessed lineouts, the following setup is recommended:

- Channel-5 volume and channel-6 volume should be set for a constant output, such as 0 dB.
- Bass and treble for channels 5 and 6 can be used if desired.
- DRC1 should be bypassed for channels 5 and 6.
- If a downmix is desired on channels 5 and 6 as lineout, the downmixing can be performed using the channel-5 and channel-6 input mixers.
- The operation of the channel-5 and -6 biquads is unaffected by the 6-/8-channel configuration setting.

### 5.3.4 Recovery from Clock Error

The TAS5558 can be set either to perform a volume ramp up during the recovery sequence of a clock error or simply to come up in the last state (or desired state if a volume or tone update was in progress). This feature is enabled via I<sup>2</sup>C system control register 0x03.

### 5.3.5 Power-Supply Volume-Control Enable

The power-supply volume control (PSVC) can be enabled and disabled via I<sup>2</sup>C register 0xE0. The subwoofer PWM output is always controlled by the PSVC. When using PSVC the subwoofer cannot be used as lineout.

### 5.3.6 Volume and Mute Update Rate

The TAS5558 has fixed soft volume and mute ramp durations. The ramps are linear. The soft volume and mute ramp rates are adjustable by programming the I<sup>2</sup>C register 0xD0 for the appropriate number of steps to be 512, 1024, or 2048. The update is performed at a fixed rate regardless of the sample rate.

- In normal speed, the update rate is 1 step every  $4/f_s$  seconds.
- In double speed, the update is 1 step every  $8/f_s$  seconds.
- In quad speed, the update is 1 step every  $16/f_s$  seconds.

Because of processor loading, the update rate can increase for some increments by one step every  $1/f_s$  to  $3/f_s$ . However, the variance of the total time to go from 18 dB to mute is less than 25%.

**Table 5-7. Volume Ramp Periods in ms**

NUMBER OF STEPS	SAMPLE RATE (kHz)	
	44.1, 88.2, 176.4	32, 48, 96, 192
512	46.44	42.67
1024	92.88	85.33
2048	185.76	170.67

### 5.3.7 Modulation Index Limit

PWM modulation is a linear function of the audio signal. When the audio signal is 0, the PWM modulation is 50%. When the audio signal increases toward full scale, the PWM modulation increases toward 100%. For negative signals, the PWM modulations fall below 50% toward 0%.

However, the maximum possible modulation does have a limit. During the off time period, the power stage connected to the TAS5558 output needs to get ready for the next on-time period. The maximum possible modulation is then set by the power stage requirements. The default modulation index limit setting is 93.7%; however, some power stages may require a lower modulation limit. See the applicable power stage data sheet for details on setting the modulation index limit. The default setting of 93.7% can be changed in the modulation index register (0x16).

## 5.4 Master Clock and Serial Data Rate Controls

On the TAS5558, the internal master clock is derived from the MCLK input and the internal sampling rate will be either 88.1 kHz/96 kHz (double speed mode) or 174.2 kHz/192 kHz (quad speed mode).

The requirement of MCLK on the TAS5558 means a 4 wire I2S interface will be needed (MCLK, SCLK, LRCLK, DATA)

The TAS5558 can detect MCLK and the data rate automatically.

The MCLK frequency can be  $64 f_s$ ,  $128 f_s$ ,  $196 f_s$ ,  $256 f_s$ ,  $384 f_s$ ,  $512 f_s$ , or  $768 f_s$ .

When the ASRC is bypassed, The TAS5558 operates with the serial data interface signals LRCLK and SCLK synchronized to MCLK. However, the phase relationship of these signals has no constraint.

The TAS5558 accepts a  $64 f_s$  SCLK rate and a  $1 f_s$  LRCLK.

If the phase of SCLK or LRCLK drifts more than  $\pm 10$  MCLK cycles since the last reset, the TAS5558 senses a clock error and resynchronizes the clock timing.

The clock and serial data interface have several control parameters:

- MCLK ratio ( $64 f_s$ ,  $128 f_s$ ,  $196 f_s$ ,  $256 f_s$ ,  $384 f_s$ ,  $512 f_s$ , or  $768 f_s$ ) – I<sup>2</sup>C parameter
- Data rate (32, 44.1, 48, 88.2, 96, 176.4, 192 kHz) – I<sup>2</sup>C parameter
- AM mode enable/disable – I<sup>2</sup>C parameter

### 5.4.1 192kHz Native Processing Mode

The TAS5558 ASRC defaults to 96kHz at startup. This means all DAP processing and filter calculations should be based on 96kHz sample rate.

However, the TAS5558 is also capable of processing content at 192kHz (with a reduced channel count).

To enable 192kHz native mode

- Write to 0xC5 ASRC Mode Control
- Set D20 = 1 (Serial clock output sampling rate is the internal sampling rate)
- Set D1:0 = 01 (192kHz Sampling Rate)
- 0xC5 = 0011 0001

DAP processing and filter calculations should be based on 192kHz sample rate. This mode should be used with an incoming I2S rate of 192kHz

### 5.4.2 Supported MCLK frequencies on the TAS5558

As the MCLK directly drives the ASRC and the Digital Audio Processor on the TAS5558, there are some specific multiples of the  $f_s$  that are supported. The MCLK frequency must be high enough to allow the 64x internal clock to be generated. Also since this clock must be generated by dividing down the MCLK, the division factor must also be integer. The combinations marked red are not supported due to frequency too low/high and the combinations marked blue are not supported due to non-integer division factor.

For a post ASRC rate of 96kHz, a minimum master clock of 6.144MHz is required (5.644MHz for 88.2). The input data rate and its related MCLK must be high enough to support this rate, and be an integer division. For Example - if the incoming data rate is 48kHz, then a 64fs MCLK will not be high enough. ( $48000 \times 64 = 3.072\text{MHz}$ ). This is shown below as "0.5" - that is, 0.5x the minimum rate.

**Table 5-8. TAS5558 Supported incoming MCLK for 88.2/96kHz Post ASRC Output (Ratio vs. required clock)**

MCLKFS	Incoming Data Rate FS (kHz)			
	32	44.1/48	88.2/96	176.4/192
64	0.33	0.35	1.00	2.00
128	0.67	1.00	2.00	4.00
192	1.00	1.50	3.00	6.00
256	1.33	2.00	4.00	8.00
384	2.00	3.00	6.00	12.00
512	2.67	4.00	8.00	16.00
768	4.00	6.00	12.00	24.00

**Table 5-9. TAS5558 Supported incoming MCLK for 176.4/192kHz Post ASRC Output (Ratio vs. required clock)**

MCLKFS	Incoming Data Rate FS (kHz)			
	32	44.1/48	88.2/96	176.4/192
64	0.17	0.25	0.5	1.00
128	0.33	0.50	1.00	2.00
192	0.50	0.75	1.50	3.00
256	0.67	1.00	2.00	4.00
384	1.00	1.50	3.00	6.00
512	1.33	2.00	4.00	8.00
768	2.00	3.00	6.00	12.00

### 5.4.3 PLL Operation

The TAS5558 uses two internal clocks generated by two internal phase-locked loops (PLLs), the digital PLL (DPLL) and the analog PLL (APLL). The APLL provides the reference clock for the PWM. The DPLL provides the reference clock for the digital audio processor and the control logic.

The master clock MCLK input provides the input reference clock for the APLL. The on chip internal oscillator provides a time base to support a number of operations, including the detection of the MCLK ratio, the data rate, and clock error conditions. The internal oscillator time base provides a constant rate for all controls and signal timing.

Even if MCLK is not present, the TAS5558 can receive and store I<sup>2</sup>C commands and provide status.

#### 5.4.4 MCLK Ratio Auto Detection

The MCLK Rate auto detection logic determines the MCLK ratio from 64Fs, 128Fs, 196Fs, 256Fs, 384Fs, 512Fs, to 768Fs. This feature is enabled only when the I2C settings -/Enable Clock Auto Detection is enabled. The TAS5558 will store the auto detected MCLK ratio in the clock control register. This value can be read via I2C.

When TAS5558 detects an MCLK rate changes it performs:

- A Soft Mute sequence (no volume ramp down).
- Updates the MCLK rate.
- Waits 5 ms for the PLLs to stabilize.
- Performs a unmute sequence and resumes operation.

Only specific external MCLK rates can be supported to generate the Native/Internal Sampling/Output of ASRC rate. MCLK should be an integer multiple of 64FS (FS of internal processing rate - e.g. if you want to ASRC to 96kHz, then MCLK should be 6.144MHz (or integer multiple of it). e.g. 18.432MHz would still be accepted, as the device can integer divide by a non power of 2.

#### 5.5 Bank Controls (ASRC Bypass only)

The TAS5558 permits the user to specify and assign sample-rate-dependent parameters for biquad, loudness, DRC, and tone in one of three banks that can be manually selected or selected automatically based on the data sampling rate. Users should bear in mind that as 192kHz content is decimated down to 96kHz for processing, no additional banks are required for 192kHz content (simply use the 96kHz coefficients). Each bank can be enabled for one or more specific sample rates via I<sup>2</sup>C bank control register 0x40. Each bank set holds the following values:

- Coefficients for seven biquads ( $7 \times 5 = 35$  coefficients) for each of the eight channels (registers 0x51–0x88)
- Coefficients for one loudness biquad (register 0x95)
- DRC1 energy and (1 – energy) values (register 0x98)
- DRC1 attack, (1 – attack), decay, (1 – decay) values (register 0x9C)
- DRC2 energy and (1 – energy) values (register 0x9D)
- DRC2 attack, (1 – attack), decay, (1 – decay) values (register 0xA1)
- Five bass filter-set selections (register 0xDA)
- Five treble filter-set selections (register 0xDC)

The default selection for bank control is manual bank with bank 1 selected. Note that if bank switching is used, bank 2 and bank 3 must be programmed on power up, because the default values are all zeroes. If bank switching is used and bank 2 and bank 3 are not programmed correctly, then the output of the TAS5558 could be muted when switching to those banks.

##### 5.5.1 Manual Bank Selection

The three bank-selection bits of the bank control register allow the appropriate bank to be manually selected (000 = bank 1, 001 = bank 2, 010 = bank 3). In the manual mode, when a write occurs to the biquad, DRC, or loudness coefficients, the currently selected bank is updated. If audio data is streaming to the TAS5558 during a manual bank selection, the TAS5558 first performs a mute sequence, then performs the bank switch, and finally restores the volume using an unmute sequence.

A mute command initiated by the bank-switch mute sequence overrides an unmute command or a volume command. While a mute is active, the commanded channels are muted. When a channel is unmuted, the volume level goes to the last commanded volume setting that has been received for that channel.

If MCLK or SCLK is stopped, the TAS5558 performs a bank-switch operation. If the clocks start up once the manual bank-switch command has been received, the bank-switch operation is performed during the 5-ms, silent-start sequence.

## 5.5.2 Automatic Bank Selection

To enable automatic bank selection, a value of 3 is written into the bank-selection bits of the bank control register. Banks are associated with one or more sample rates by writing values into the bank 1 or bank 2 data-rate selection registers. The automatic bank selection is performed when a frequency change is detected according to the following scheme:

1. The system scans bank-1 data-rate associations to see if bank 1 is assigned for that data rate.
2. If bank 1 is assigned, then the bank-1 coefficients are loaded.
3. If bank 1 is not assigned, the system scans bank 2 to see if bank 2 is assigned for that data rate.
4. If bank 2 is assigned, the bank-2 coefficients are loaded.
5. If bank 2 is not assigned, the system loads the bank-3 coefficients.

The default is that all frequencies are enabled for bank 1. This default is expressed as a value of all 1s in the bank-1 auto-selection byte and all 0s in the bank-2 auto-selection byte.

### 5.5.2.1 Coefficient Write Operations While Automatic Bank Switch Is Enabled

In automatic mode, if a write occurs to the tone, EQ, DRC, or loudness coefficients, the bank that is written to is the current bank.

## 5.5.3 Bank Set

Bank set is used to provide a secure way to update the bank coefficients in both the manual and automatic switching modes without causing a bank switch to occur. Bank-set mode does not alter the current bank register mapping. It simply enables any bank coefficients to be updated while inhibiting any bank switches from taking place. In manual mode, this enables the coefficients to be set without switching banks. In automatic mode, this prevents a clock error or data-rate change from corrupting a bank coefficient write.

To update the coefficients of a bank, a value of 4, 5, or 6 is written into in the bank-selection bits of the bank control register. This enables the tone, EQ, DRC, and loudness coefficient values of bank 1, 2, or 3, respectively, to be updated.

Once the coefficients of the bank have been updated, the bank-selection bits are then returned to the desired manual or automatic bank-selection mode.

## 5.5.4 Bank-Switch Timeline

After a bank switch is initiated (manual or automatic), no I<sup>2</sup>C writes to the TAS5558 should occur before a minimum of 186 ms. This value is determined by the volume ramp rates for a particular sample rate.

## 5.5.5 Bank-Switching Example 1

**Problem:** The audio unit containing a TAS5558 needs to handle different audio formats with different sample rates. Format #1 requires  $f_s = 32/38$  kHz, format #2 requires  $f_s = 44.1$  kHz/48kHz, and format #3 requires  $f_s = 88.2/96$  kHz. The sample-rate-dependent parameters in the TAS5558 require different coefficients and data depending on the sample rate.

**Strategy:** Use the TAS5558 bank-switching feature to allow for managing and switching three banks associated with the three sample rates, 32/38 kHz (bank 1), 44.1/48 kHz (bank 2), and 88.2/96 kHz (bank 3).

One possible algorithm is to generate, load, and automatically manage bank switching for this problem:

1. Generate bank-related coefficients for sample rates of 32 kHz, 48 kHz, and 96 kHz, and include the same in the microprocessor-based TAS5558 I<sup>2</sup>C firmware.
2. On TAS5558 power up or reset, the microprocessor runs the following TAS5558 initialization code:
  - (a) Update bank 1 (write 0x0004 C060 to register 0x40).
  - (b) Write bank-related I<sup>2</sup>C registers with appropriate values for bank 1.

- (c) Write bank 2 (write 0x0005 C060 to register 0x40).
  - (d) Load bank-related I2C registers with appropriate values for bank 2.
  - (e) Write bank 3 (write 0x0006 C060 to register 0x40).
  - (f) Load bank-related I2C registers with appropriate values for bank 3.
  - (g) Select automatic bank switching (write 0x0003 C060 to register 0x40).
3. When the audio media changes, the TAS5558 automatically detects the incoming sample rate and automatically switches to the appropriate bank.

In this example, any sample rates other than 32 kHz and 44.1 kHz use bank 3. If other sample rates are used, then the banks must be set up differently.

## 6 System Power Controller

### 6.1 Energy Manager

TAS5558 has an Energy Manager that can be used to monitor/control the overall energy in the system. The key features are:

1. There are separate controllers for Satellite (EMO1) and Sub (EMO2) channels. If EMO2 is not enabled, then the EMO1 pin is OR'd with the output of the subwoofer comparator.
2. The satellite channels participating in the energy estimation are selectable. For example, in the 5.1 Mode, the line out channels can be programmed to not participate in the energy estimation.
3. There is a mixer for each channel before mixing. This is for scaling each channel before adding. The energy of all participating satellite channels are added and compared with a programmable threshold. If the value crosses the threshold, the `satellite_over_power` bit in the status register is set. Similarly, if the overall energy is lower than another programmable register, the `satellite_idle` bit in the status register is set. Both these bits are "sticky," meaning once set, the external controller has to write a "0" to clear the bit
4. Similar to the satellite channel, the sub channel energy is also estimated and compared against an upper and lower threshold. If above the upper threshold, the `sub_over_power` bit is set and if below the threshold, the `sub_idle_bit` are set. These are also "sticky" bits. Sub channels also have a disable pin that bypass energy comparison.
5. An OR of the 4 status bits are available on EMO pin

External controller on the detection of EMO interrupt (pin going high) can read the status register for more information.

The controller can shutdown the PWM for idle mode and or reduce channel energy to reduce overall power. The Controller discerns more details on the EMO condition by using the status and enable bits. Figure 6-1 shows the EMO system for satellite channels. A similar EMO system for the subwoofer channel also will be implemented. The EMO pin is shared between satellite and sub channels.

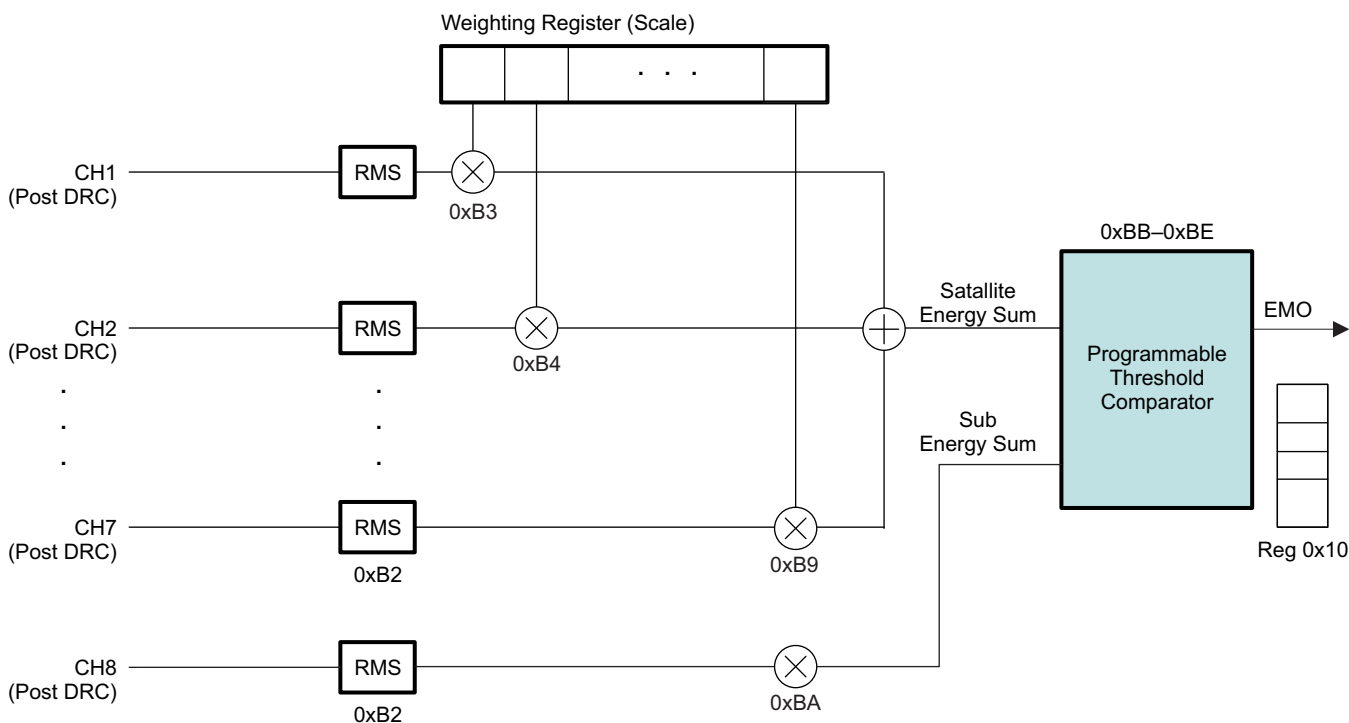

Figure 6-1. Energy Manager

## 6.2 Programming Energy Manager

Energy Manager related registers are 0xBA to 0xBE. 0xB2 is a 16 byte averaging filter (alpha filter) for both satellite and sub channel. The scaling coefficients are 0xB3 to 0xBA that multiplies energy of each channel with a scaling factor. The threshold registers are (0xBB, 0xBC, 0xBD and 0xBE) and 0x10 for the results register.

**Table 6-1. Energy Manager Status Register (x10)**

D3	D2	D1	D0	FUNCTION
–	–	–	0/1	Energy below the low threshold for satellite channels
–	–	0/1	–	Energy above the high threshold for satellite channels
–	0/1	–	–	Energy below the low threshold for sub-woofer channel
0/1	–	–	–	Energy above the high threshold for sub-woofer channels

So provision to read the whole byte and a way to clear the 4 LSB's (one by one)

## 6.3 AM Avoidance Strategies

### 6.3.1 Frequency Scaling AM Avoidance

The AM avoidance strategy exploits the presence of the ASRC. The APLL output frequency is directly varied by varying the multiplier ratio in the PLL loop. The dividers to generate clocks from the APLL are fixed at their nominal division factor, so the result is that the internal sampling rate is changing accordingly.

The ASRC will adapt with this changing output rate (the internal sampling rate) and convert the incoming sampling rates to this rate accordingly. The rest of the circuit does not change and operates normally, but since the APLL output frequency is varied while the clock dividers are fixed, the PWM carrier frequency becomes varied also, which is the goal of this AM avoidance strategy.

This shift in processing rate will effect time-domain digital processing, such as the EQ's and DRC's decay values by the value in Freq\_Error below.

**Table 6-2. APLL/DAP/ASRC Clock Frequencies with New AM Avoidance Strategy**

Mode	Input FS	MCLK	Prescale	Feedback	DCLK	Internal SR	DAP CLK	# cycles per FS	ASRC CLK	PWM rate	Freq_Error
Normal	8 - 192k	12288	4	64	196608	96	131072	1365.33	98304	384	0.00%
AM#1	8 - 192k	12288	4	62	190464	93	126976	1365.33	95232	372	-3.13%
AM#2	8 - 192k	12288	4	60	184320	90	12288	1365.33	92160	360	-6.25%
AM#3	8 - 192k	12288	4	58	178176	87	118784	1365.33	89088	348	-9.38%
AM#4	8 - 192k	12288	4	56	172032	84	114688	1365.33	86016	336	-12.50%



## 7 Electrical Specifications

### 7.1 Absolute Maximum Ratings<sup>(1)</sup>

Supply voltage, DVDD1 and DVDD2		-0.3 V to 3.9 V
Supply voltage, AVDD and AVDD_PWM		-0.3 V to 3.9 V
Input voltage	3.3-V digital input	-0.5 V to DVDD + 0.5 V
	5-V tolerant <sup>(2)</sup> digital input	-0.5 V to 6 V
$I_{IK}$	Input clamp current ( $V_I < 0$ or $V_I > 1.8$ V)	$\pm 20$ $\mu$ A
$I_{OK}$	Output clamp current ( $V_O < 0$ or $V_O > 1.8$ V)	$\pm 20$ $\mu$ A
$T_A$	Operating free-air temperature	0°C to 85°C
$T_{stg}$	Storage temperature range	-65°C to 150°C

- (1) Stresses beyond those listed under *Absolute Maximum Ratings* may cause permanent damage to the device. These are stress ratings only. Functional operation of the device at these or any other conditions beyond those indicated under *Recommended Operating Conditions* are not implied. Exposure to absolute-maximum-rated conditions for extended periods may affect device reliability.
- (2) 5-V tolerant signals are RESET, PDN, MUTE, HP\_SEL, SCLK, LRCLK, MCLK, SDIN1, SDIN2, SDIN3, SDIN4, SDA, and SCL.

### 7.2 Dissipation Rating Table (High-k Board, 115°C Junction)

PACKAGE	$T_A \leq 25^\circ\text{C}$ POWER RATING	DERATING FACTOR ABOVE $T_A = 25^\circ\text{C}$	$T_A = 85^\circ\text{C}$ POWER RATING
DCA			

### 7.3 Dynamic Performance

At recommended operating conditions at (25°C, 3.3V Power Supplies with 48kHz input data) unless otherwise noted.

PARAMETER	TEST CONDITIONS	MIN	NOM	MAX	UNIT
Dynamic range	TAS5558 A-weighted (Test Range: 20Hz to 20kHz. $f_s = 96$ kHz).		105		dB
Total harmonic distortion	TAS5558 output (1kHz @ -1dBFS)		0.01%		
Frequency response	32-kHz to 96-kHz sample rates (Test Range 20Hz - 20kHz)		$\pm 0.1$		dB
	176.4, 192-kHz sample rates (Test Range 20Hz - 20kHz)		$\pm 0.2$		

### 7.4 Recommended Operating Conditions

Over 0°C to 85°C

		MIN	NOM	MAX	UNIT
Digital supply voltage, DVDD1 and DVDD2		3	3.3	3.6	V
Analog supply voltage, AVDD and AVDD_PWM		3	3.3	3.6	V
$V_{IH}$	High-level input voltage	3.3 V		2	V
		5-V tolerant <sup>(1)</sup>		2	
		1.8-V LVCMOS (XTL_IN)		1.26	
$V_{IL}$	Low-level input voltage	3.3 V		0.8	V
		5-V tolerant <sup>(1)</sup>		0.8	
		1.8-V (XTL_IN)		0.54	
$T_A$	Operating ambient-air temperature range	0	25	85	°C
$T_J$	Operating junction temperature range	0		105	°C

- (1) 5-V tolerant signals are SDA, SCL, RESET, PDN, MUTE, HP\_SEL, SCLK, LRCLK, MCLK, SDIN1, SDIN2, SDIN3, and SDIN4

### 7.5 Electrical Characteristics

At recommended operating conditions - 25°C Operating Temp, 3.3V Power Supplies with 48kHz input data unless otherwise specified

PARAMETER		TEST CONDITIONS	MIN	TYP	MAX	UNIT
V <sub>OH</sub>	High-level output voltage	3.3-V TTL and 5-V tolerant <sup>(1)</sup>	I <sub>OH</sub> = -4 mA	2.4		V
		1.8-V LVCMOS (XTL_OUT)	I <sub>OH</sub> = -0.55 mA	1.44		
V <sub>OL</sub>	Low-level output voltage	3.3-V TTL and 5-V tolerant <sup>(1)</sup>	I <sub>OL</sub> = 4 mA		0.5	V
		1.8-V LVCMOS (XTL_OUT)	I <sub>OL</sub> = 0.75 mA		0.5	
I <sub>OZ</sub>	High-impedance output current	3.3-V TTL			±20	µA
I <sub>IL</sub>	Low-level input current	3.3-V TTL	V <sub>I</sub> = V <sub>IL</sub>		±1	µA
		1.8-V LVCMOS (XTL_IN)	V <sub>I</sub> = V <sub>IL</sub>		±1	
		5-V tolerant <sup>(2)</sup>	V <sub>I</sub> = 0 V, DVDD = 3 V		±1	
I <sub>IH</sub>	High-level input current	3.3-V TTL	V <sub>I</sub> = V <sub>IH</sub>		±1	µA
		1.8-V LVCMOS (XTL_IN)	V <sub>I</sub> = V <sub>IH</sub>		±1	
		5-V tolerant <sup>(2)</sup>	V <sub>I</sub> = 5.5 V, DVDD = 3 V		±1	
I <sub>DD</sub>	Input supply current	Digital supply voltage, DVDD	Input f <sub>S</sub> = 48 kHz	220		mA
			Power down	9		
		Analog supply voltage, AVDD	Input f <sub>S</sub> = 48 kHz	8		
			Power down	8		

(1) 5-V tolerant signals are SDA, SCL, RESET, PDN, MUTE, HP\_SEL, SCLK, LRCLK, MCLK, SDIN1, SDIN2, SDIN3, and SDIN4.  
 (2) 5-V tolerant signals are RESET, PDN, MUTE, HP\_SEL, SCLK, LRCLK, MCLK, SDIN1, SDIN2, SDIN3, SDIN4, SDA, and SCL.

### 7.6 SRC Performance

ASRC Performance is shown in

Table 7-1. ASRC Performance

Attribute	Value
SRC Latency	102.53125/FSin + 36.46875/FSout
THD+N @ 1kHz	
Pass Band Ripple (worst case)	±0.05dB
SRC Channel Gain	<1 (slightly lower to compensate for ripple)
Stop Band Attenuation	130dB
Pass Band Edge	0.425 FS-in
Stop Band Edge	0.575 FS-in

### 7.7 Switching Characteristics

#### 7.7.1 Clock Signals

PLL input parameters and external filter components over recommended operating conditions (unless otherwise noted)

PARAMETER		TEST CONDITIONS	MIN	TYP	MAX	UNIT
f <sub>MCLKI</sub>	Frequency, MCLK (1/t <sub>cyc2</sub> )		2		50	MHz
	<b>TAS5558:</b> MCLK duty cycle		40%	50%	60%	
	<b>TAS5558:</b> MCLK minimum high time	≥2-V MCLK = 49.152 MHz, within the min and max duty cycle constraints	5			ns
	<b>TAS5558:</b> MCLK minimum low time	≤0.8-V MCLK = 49.152 MHz, within the min and max duty cycle constraints	5			ns
	LRCLK allowable drift before LRCLK reset				10	MCLKs
	External PLL filter capacitors	SMD 0603 X7R		100		nF

PLL input parameters and external filter components over recommended operating conditions (unless otherwise noted)

PARAMETER	TEST CONDITIONS	MIN	TYP	MAX	UNIT
External PLL filter capacitors	SMD 0603 X7R		10		nF
External PLL filter resistors	SMD 0603, metal film, 1%		200		$\Omega$
External VRA_PWM decoupling C14	SMD 0603 X7R		100		nF

## 7.7.2 Serial Audio Port

Serial audio port slave mode over recommended operating conditions (unless otherwise noted)

PARAMETER		TEST CONDITIONS	MIN	TYP	MAX	UNIT
$f_{\text{SCLKIN}}$	SCLK input frequency	$C_L = 30 \text{ pF}$	2.048		12.288	MHz
$t_{\text{su1}}$	Setup time, LRCLK to SCLK rising edge		10			ns
$t_{\text{h1}}$	Hold time, LRCLK from SCLK rising edge		10			ns
$t_{\text{su2}}$	Setup time, SDIN to SCLK rising edge		10			ns
$t_{\text{h2}}$	Hold time, SDIN from SCLK rising edge		10			ns
	LRCLK frequency		32	48	192	kHz
	SCLK rising edges between LRCLK rising edges		64		64	SCLK edges
	SDOUT delay with respect to SCLK output (load = 30pF)				20	ns

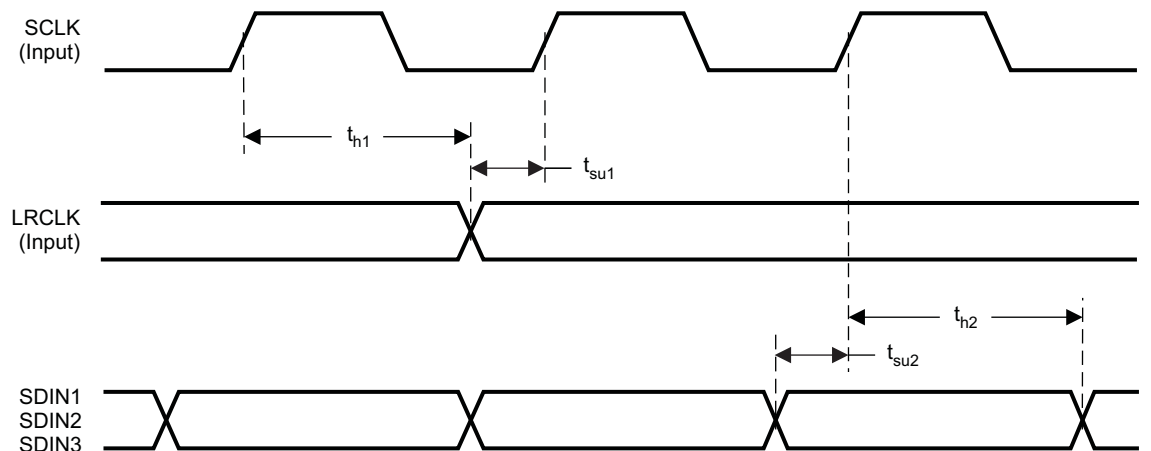

T0026-01

Figure 7-1. Slave Mode Serial Data Interface Timing

## 7.7.3 I<sup>2</sup>C Serial Control Port Operation

Timing Characteristics for I<sup>2</sup>C Interface Signals over recommended operating conditions (unless otherwise noted)

PARAMETER	TEST CONDITIONS	STANDARD MODE		FAST MODE		UNIT
		MIN	MAX	MIN	MAX	
$f_{\text{SCL}}$	SCL clock frequency	0	100	0	400	kHz
$t_{\text{HD-STA}}$	Hold time (repeated) START condition. After this period, the first clock pulse is generated.	4		0.6		$\mu\text{s}$
$t_{\text{LOW}}$	LOW period of the SCL clock	4.7		1.3		$\mu\text{s}$
$t_{\text{HIGH}}$	HIGH period of the SCL clock	4		0.6		$\mu\text{s}$
$t_{\text{SU-STA}}$	Setup time for repeated START	4.7		0.6		$\mu\text{s}$
$t_{\text{SU-DAT}}$	Data setup time	250		200		ns
$t_{\text{HD-DAT}}$	Data hold time <sup>(1)</sup> <sup>(2)</sup>	0	3.45	0	0.9	$\mu\text{s}$
$t_r$	Rise time of both SDA and SCL		1000	$20 + 0.1 C_b$ <sup>(3)</sup>	500 <sup>(4)</sup>	ns

- (1) Note that SDA does not have the standard I<sup>2</sup>C specification 300-ns hold time and that SDA must be valid by the rising and falling edges of SCL. TI recommends that a 3.3-k $\Omega$  pullup resistor be used to avoid potential timing issues.
- (2) A fast-mode I<sup>2</sup>C-bus device can be used in a standard-mode I<sup>2</sup>C-bus system, but the requirement  $t_{\text{SU-DAT}} \geq 250 \text{ ns}$  must then be met. This is automatically the case if the device does not stretch the LOW period of the SCL signal. If such a device does stretch the LOW period of the SCL signal, it must output the next data bit to the SDA line  $t_{r\text{-max}} + t_{\text{SU-DAT}} = 1000 + 250 = 1250 \text{ ns}$  (according to the standard-mode I<sup>2</sup>C bus specification) before the SCL line is released.
- (3)  $C_b$  = total capacitance of one bus line in pF.
- (4) Rise time varies with pullup resistor.



### 7.7.4 Reset Timing ( $\overline{\text{RESET}}$ )

Control signal parameters over recommended operating conditions (unless otherwise noted)

PARAMETER		MIN	TYP	MAX	UNIT
$t_{r(\text{DMSTATE})}$	Time to Non PWM Switching low		400		ns
$t_{w(\text{RESET})}$	Pulse duration, $\overline{\text{RESET}}$ active	400		None	ns
$t_{r(\text{I2C\_ready})}$	Time to enable I <sup>2</sup> C		5		ms

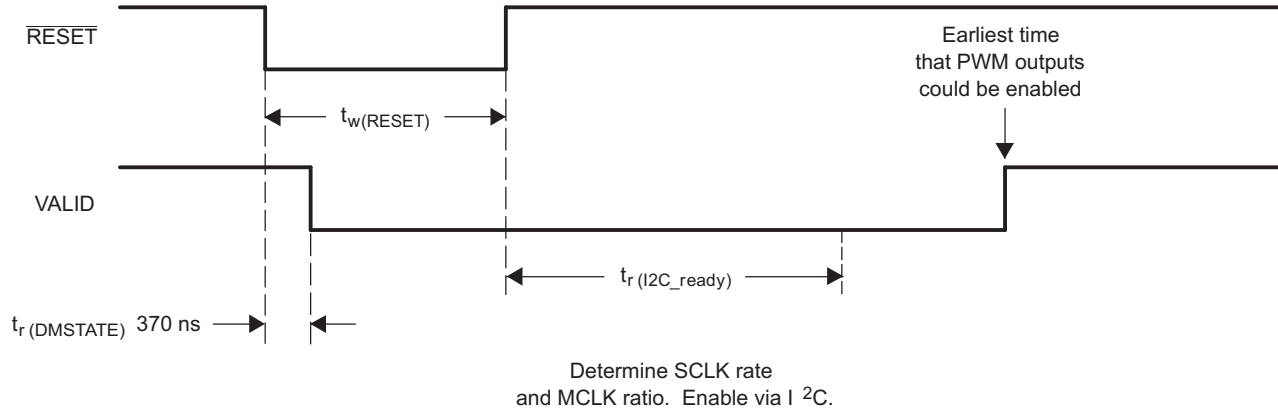

T0029-04

Figure 7-4. Reset Timing

### 7.7.5 Power-Down ( $\overline{\text{PDN}}$ ) Timing

Control signal parameters over recommended operating conditions (unless otherwise noted)

PARAMETER		MIN	TYP	MAX	UNIT
$t_{p(\text{DMSTATE})}$	Time to Non PWM Switching low			650	$\mu\text{s}$
	Number of MCLKs preceding the release of $\overline{\text{PDN}}$	5			
$t_{\text{su}}$	Device startup time		200		$\mu\text{s}$
	Time to audio output		160		mS

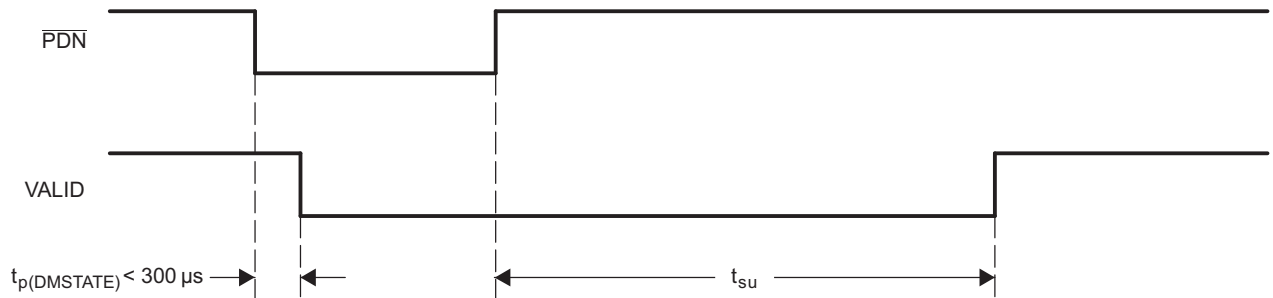

T0030-03

Figure 7-5. Power-Down Timing

### 7.7.6 Back-End Error ( $\overline{BKND\_ERR}$ )

Control signal parameters over recommended operating conditions (unless otherwise noted)

PARAMETER		MIN	TYP	MAX	UNIT
$t_{w(ER)}$	Pulse duration, $\overline{BKND\_ERR}$ active	350		None	ns
$t_{p(valid\_low)}$	Minimum amount of time that device asserts VALID low.			<100	$\mu$ s
$t_{p(valid\_high)}$	I <sup>2</sup> C programmable to be between <1mS to 1.2 seconds (to avoid glitching with persistent $\overline{BKND\_ERR}$ )	-25		25	% of interval

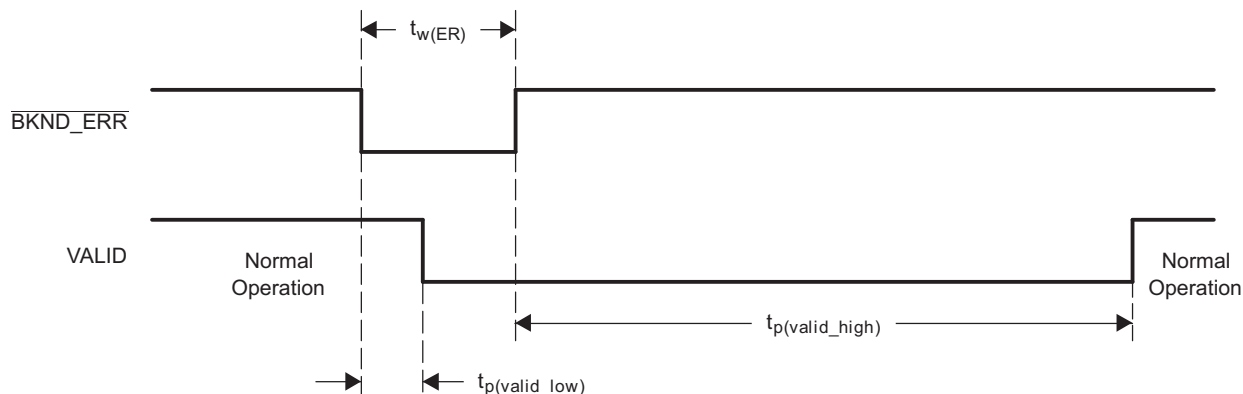

T0031-03

Figure 7-6. Error-Recovery Timing

### 7.7.7 Mute Timing ( $\overline{MUTE}$ )

Control signal parameters over recommended operating conditions (unless otherwise noted)

PARAMETER		MIN	TYP	MAX	UNIT
$t_{d(VOL)}$	Volume ramp time	Defined by rate setting <sup>(1)</sup>			ms

(1) See the *Volume, Treble, and Base Slew Rates Register (0xD0)* section, [Section 11.37](#).

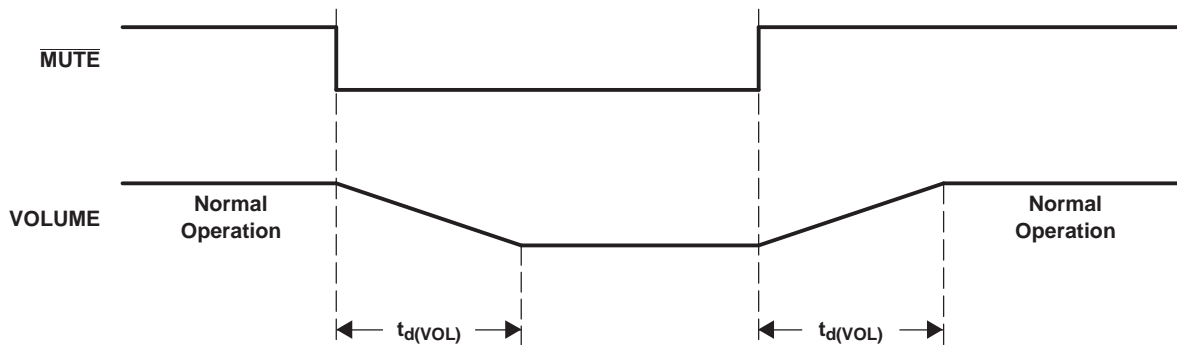

T0032-02

Figure 7-7. Mute Timing

**Note:** No I2C commands during the volume ramp up/down.

### 7.7.8 Headphone Select ( $\overline{HP\_SEL}$ )

Control signal parameters over recommended operating conditions (unless otherwise noted)

PARAMETER	MIN	TYP	MAX	UNIT
$t_{w(HP\_SEL)}$ Pulse duration, $\overline{HP\_SEL}$ active		165		ms
$t_{d(VOL)}$ Soft volume update time	Defined by rate setting <sup>(1)</sup>			ms
$t_{(SW)}$ Switchover time		165		ms

(1) See the *Volume, Treble, and Base Slew Rates Register (0xD0)* section. [Section 11.37](#).

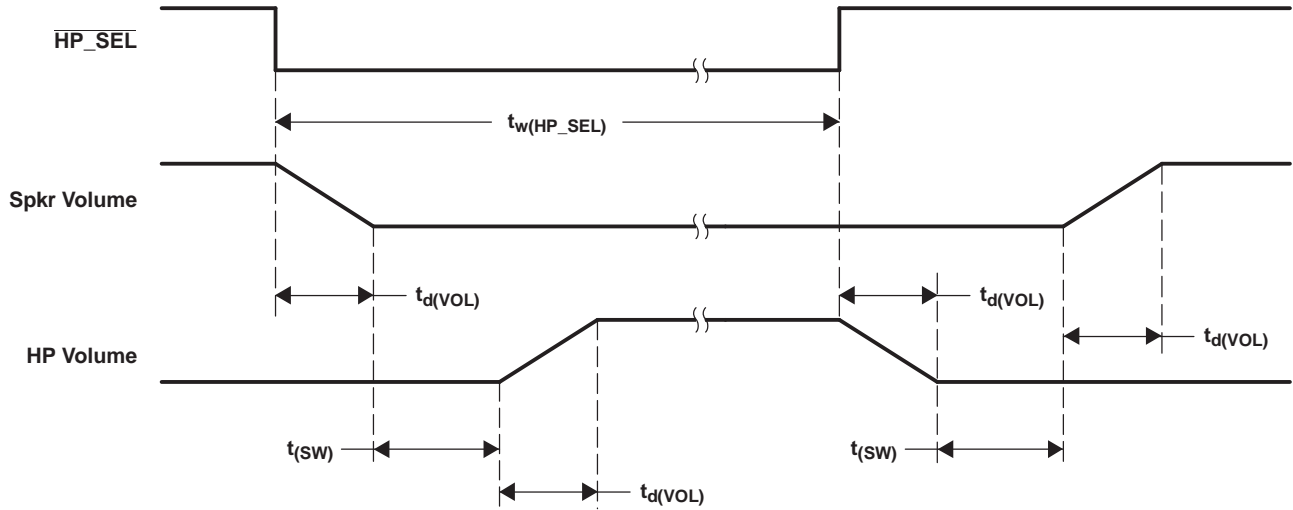

T0033-02

Figure 7-8.  $\overline{HP\_SEL}$  Timing

### 7.7.9 Volume Control

Control signal parameters over recommended operating conditions (unless otherwise noted)

PARAMETER	TEST CONDITIONS	MIN	MAX	UNIT
Maximum attenuation before mute	Individual volume, master volume, or a combination of both		-127	dB
Maximum gain	Individual volume, master volume		18	dB
Maximum volume before the onset of clipping	0-dB input, any modulation limit		0	dB
PSVC range	PSVC enabled	12, 18, or 24		dB
PSVC rate		$f_s$		
PSVC modulation		Single sided		
PSVC quantization		2048		Steps
PSVC PWM modulation limits	PSVC range = 24 dB	6% (120 : 2048)	95% (1944 : 2048)	dB



## 7.8 Serial Audio Interface Control and Timing

### 7.8.1 Input I<sup>2</sup>S Timing

I<sup>2</sup>S timing uses LRCLK to define when the data being transmitted is for the left channel and when it is for the right channel. LRCLK is low for the left channel and high for the right channel. A bit clock running at  $64 f_s$  is used to clock in the data. From the time the LRCLK signal changes state to the first bit of data on the data lines is a delay of one bit clock. The data is written MSB first and is valid on the rising edge of the bit clock. The TAS5558 masks unused trailing data bit positions.

2-Channel I<sup>2</sup>S (Philips Format) Stereo Input

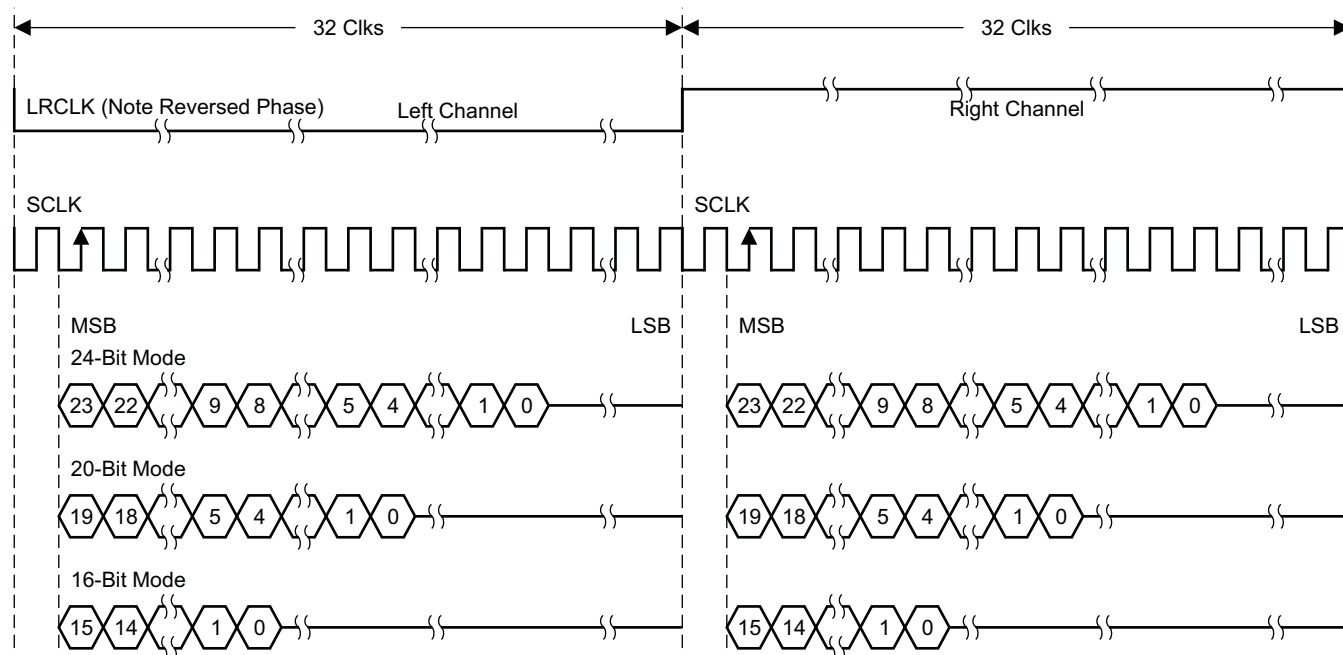

T0034-01

Figure 7-9. I<sup>2</sup>S 64- $f_s$  Format

### 7.8.2 Left-Justified Timing

Left-justified (LJ) timing uses LRCLK to define when the data being transmitted is for the left channel and when it is for the right channel. LRCLK is high for the left channel and low for the right channel. A bit clock running at  $64 f_s$  is used to clock in the data. The first bit of data appears on the data lines at the same time LRCLK toggles. The data is written MSB first and is valid on the rising edge of the bit clock. The TAS5558 masks unused trailing data bit positions.

2-Channel Left-Justified Stereo Input

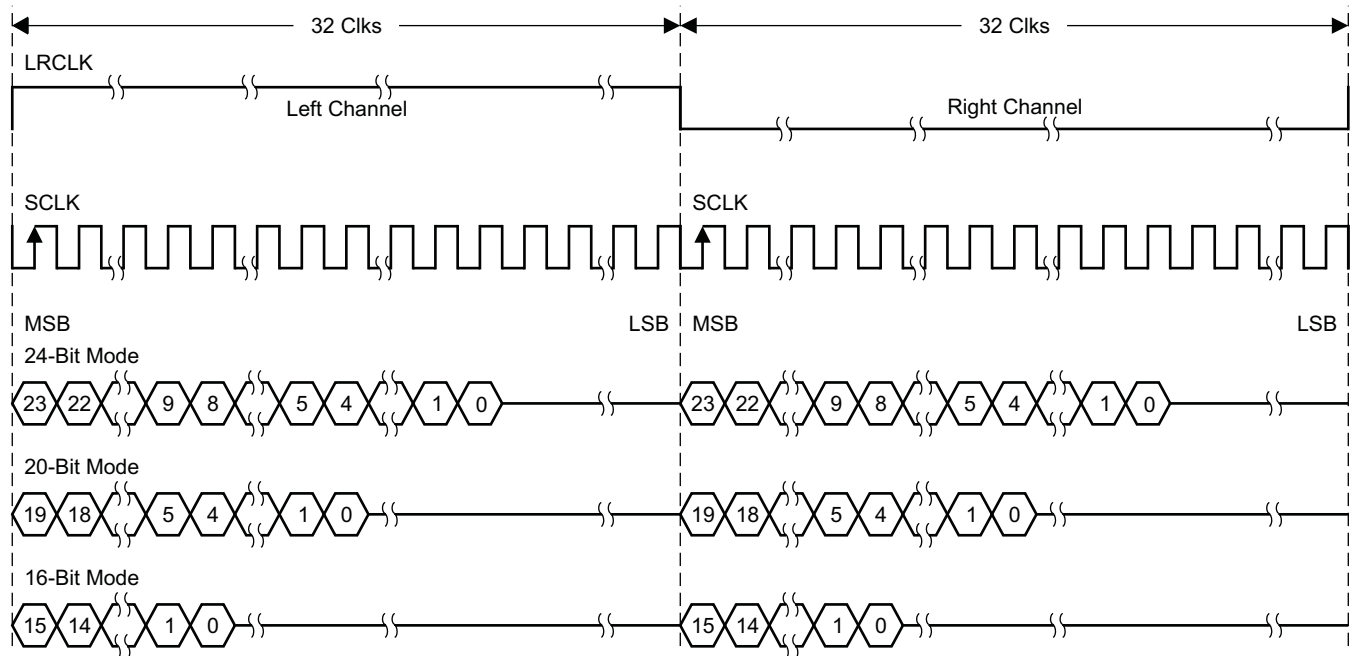

T0034-02

Figure 7-10. Left-Justified  $64-f_s$  Format

### 7.8.3 Right-Justified Timing

Right-justified (RJ) timing uses LRCLK to define when the data being transmitted is for the left channel and when it is for the right channel. LRCLK is high for the left channel and low for the right channel. A bit clock running at  $64 f_s$  is used to clock in the data. The first bit of data appears on the data lines eight bit-clock periods (for 24-bit data) after LRCLK toggles. In RJ mode the LSB of data is always clocked by the last bit clock before LRCLK transitions. The data is written MSB first and is valid on the rising edge of the bit clock. The TAS5558 masks unused leading data bit positions.

2-Channel Right-Justified (Sony Format) Stereo Input

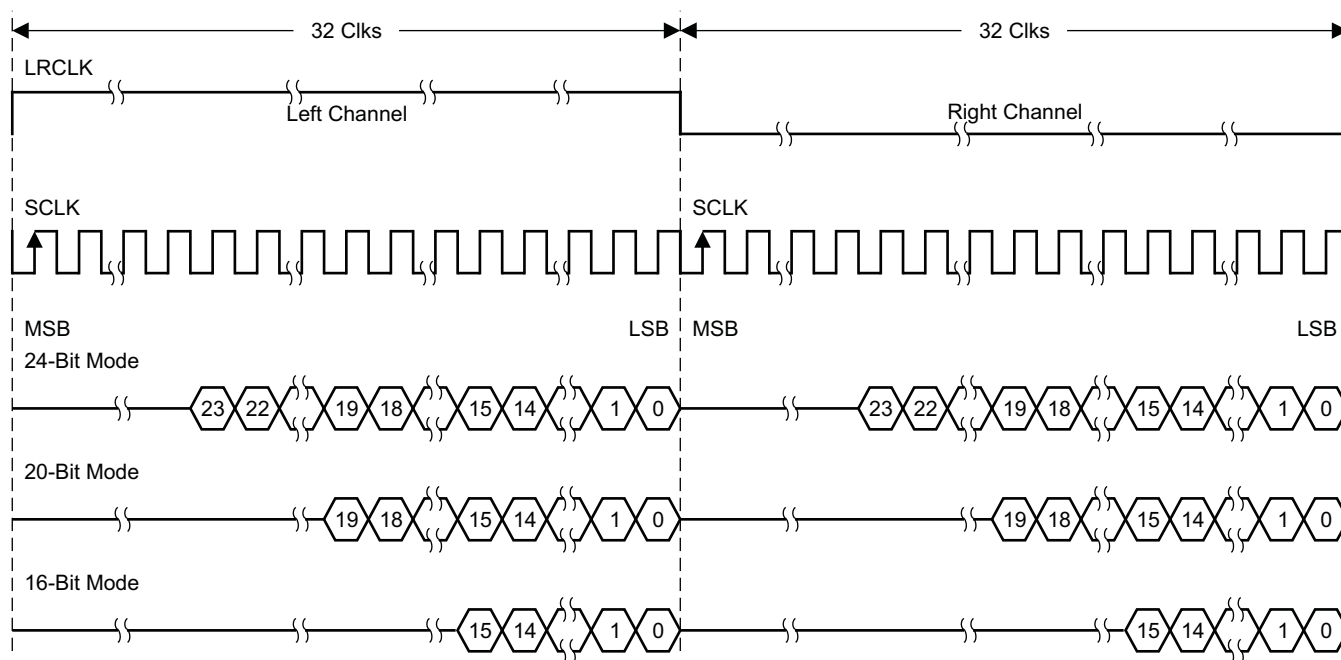

T0034-03

Figure 7-11. Right-Justified  $64\text{-}f_s$  Format

## 7.9 OUTPUT Serial Audio Output

Serial audio output formats supported are left justified (LJ), right justified (RJ) and I2S.

Serial audio output word lengths supported are 16 bits, 20 bits and 24 bits.

Other formats or word lengths are not supported.

## 7.10 I2S Master Mode

In master mode, the SDIN1/SDIN2/SDIN3/SDIN4 and optionally SDIN5 are assumed to be generated according to LRCLK and SCLK output by TAS5558.

As the SDIN5 will never go through the ASRC, the SDIN5 can be accepted with master mode only. Internally, the LRCLK and SCLK for the SDIN5 are always assumed to be the same with LRCLK and SCLK outputs. When set in I2S master mode, the I2S input/output formats should not mix I2S and LJ/RJ. If the input format is I2S then the output format must also be I2S. When the input format is not I2S then the output format must also not be I2S. Left justified and right justified can be mixed. When the SDIN5 is activated (SDOUT is not available), the LRCLKO will be the internal sample rate, that is either 96 kHz or 192 kHz. The SCLKO will be  $64 \times$  LRCLKO.

## 7.11 LRCKO and SCLKO

There are output pins for LRCLK output and SCK output. As the SDIN5 rate (which always follow internal sample rate) and the SDOOUT rate (which is 44.1 kHz or 48 kHz) is different, the LRCLKO will be the internal sample rate (96 kHz or 192 kHz) when SDIN5 is activated (SDOOUT is not available) and it will be 44.1 kHz or 48 kHz when SDOOUT is available. The SCLKO will be always 64x LRCLKO.

8.5 Master Clock Output (MCLKO) Master clock is generated from the MCLK input itself. There is a clock divider with division factor of 4, 2 or 1 that can be selected from. The default is no division

## 8 I<sup>2</sup>C Serial-Control Interface (Slave Addresses 0x36)

The TAS5558 has a bidirectional I<sup>2</sup>C interface that is compatible with the Inter-IC (I<sup>2</sup>C) bus protocol and supports both 100-kbps and 400-kbps data transfer rates for single- and multiple-byte write and read operations. This is a slave-only device that does not support a multimaster bus environment or wait state insertion. The control interface is used to program the registers of the device and to read device status.

The TAS5558 supports the standard-mode I<sup>2</sup>C bus operation (100 kHz maximum) and the fast I<sup>2</sup>C bus operation (400 kHz maximum). The TAS5558 performs all I<sup>2</sup>C operations without I<sup>2</sup>C wait cycles.

The I<sup>2</sup>C address is 0x36 if ASEL pin = '1', but if the value of the pin = '0', then respective values will be 0x34.

### 8.1 General I<sup>2</sup>C Operation

The I<sup>2</sup>C bus employs two signals—SDA (data) and SCL (clock)—to communicate between integrated circuits in a system. Data is transferred on the bus serially, one bit at a time. The address and data can be transferred in byte (8-bit) format, with the most significant bit (MSB) transferred first. In addition, each byte transferred on the bus is acknowledged by the receiving device with an acknowledge bit. Each transfer operation begins with the master device driving a start condition on the bus and ends with the master device driving a stop condition on the bus. The bus uses transitions on SDA while the clock is high to indicate start and stop conditions. A high-to-low transition on SDA indicates a start and a low-to-high transition indicates a stop. Normal data bit transitions must occur within the low time of the clock period. These conditions are shown in Figure 8-1. The master generates the 7-bit slave address and the read/write (R/W) bit to open communication with another device and then waits for an acknowledge condition. The TAS5558 holds SDA low during the acknowledge clock period to indicate an acknowledgement. When this occurs, the master transmits the next byte of the sequence. Each device is addressed by a unique 7-bit slave address plus R/W bit (1 byte). All compatible devices share the same signals via a bidirectional bus using a wired-AND connection. An external pullup resistor must be used for the SDA and SCL signals to set the high level for the bus.

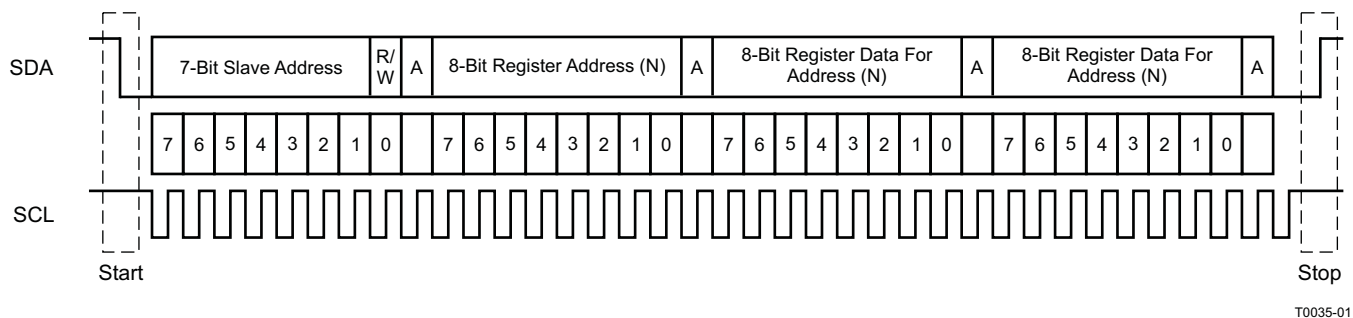

Figure 8-1. Typical I<sup>2</sup>C Sequence

The number of bytes that can be transmitted between start and stop conditions is unlimited. When the last word transfers, the master generates a stop condition to release the bus. A generic data transfer sequence is shown in Figure 8-1.

The 7-bit address for the TAS5558 is 0011011. When the R/W bit is added as the LSB, the I<sup>2</sup>C write address is 0x36 and the I<sup>2</sup>C read address is 0x37.

## 8.2 Single- and Multiple-Byte Transfers

The serial-control interface supports both single-byte and multiple-byte read/write operations for status registers and the general control registers associated with the PWM. However, for the DAP data processing registers, the serial-control interface supports only multiple-byte (four-byte) read/write operations.

During multiple-byte read operations, the TAS5558 responds with data, a byte at a time, starting at the subaddress assigned, as long as the master device continues to respond with acknowledges. If a particular subaddress does not contain 32 bits, the unused bits are read as logic 0.

During multiple-byte write operations, the TAS5558 compares the number of bytes transmitted to the number of bytes that are required for each specific subaddress. If a write command is received for a biquad subaddress, the TAS5558 expects to receive five 32-bit words. If fewer than five 32-bit data words have been received when a stop command (or another start command) is received, the data received is discarded. Similarly, if a write command is received for a mixer coefficient, the TAS5558 expects to receive one 32-bit word.

Supplying a subaddress for each subaddress transaction is referred to as random I<sup>2</sup>C addressing. The TAS5558 also supports sequential I<sup>2</sup>C addressing. For write transactions, if a subaddress is issued followed by data for that subaddress and the 15 subaddresses that follow, a sequential I<sup>2</sup>C write transaction has taken place, and the data for all 16 subaddresses is successfully received by the TAS5558. For I<sup>2</sup>C sequential write transactions, the subaddress then serves as the start address and the amount of data subsequently transmitted, before a stop or start is transmitted, determines how many subaddresses are written. As is true for random addressing, sequential addressing requires that a complete set of data be transmitted. If only a partial set of data is written to the last subaddress, the data for the last subaddress is discarded. However, all other data written is accepted; only the incomplete data is discarded.

## 8.3 Single-Byte Write

As shown in [Figure 8-2](#), a single-byte, data-write transfer begins with the master device transmitting a start condition followed by the I<sup>2</sup>C device address and the read/write bit. The read/write bit determines the direction of the data transfer. For a write data transfer, the read/write bit is a 0. After receiving the correct I<sup>2</sup>C device address and the read/write bit, the TAS5558 device responds with an acknowledge bit. Next, the master transmits the address byte or bytes corresponding to the TAS5558 internal memory address being accessed. After receiving the address byte, the TAS5558 again responds with an acknowledge bit. Next, the master device transmits the data byte to be written to the memory address being accessed. After receiving the data byte, the TAS5558 again responds with an acknowledge bit. Finally, the master device transmits a stop condition to complete the single-byte, data-write transfer.

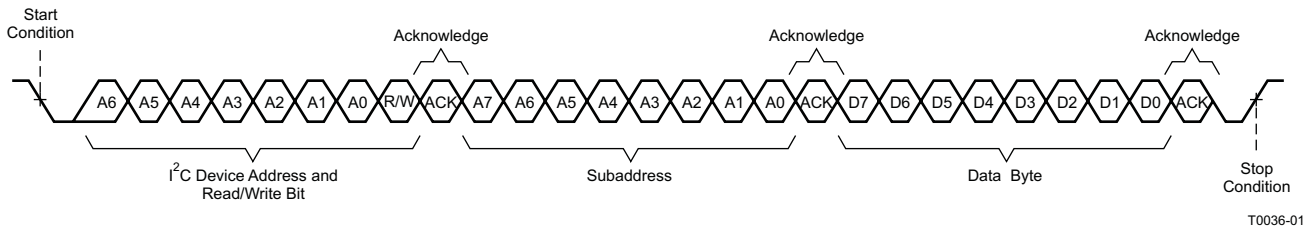

**Figure 8-2. Single-Byte Write Transfer**

## 8.4 Multiple-Byte Write

A multiple-byte, data-write transfer is identical to a single-byte, data-write transfer except that multiple data bytes are transmitted by the master device to TAS5558, as shown in Figure 8-3. After receiving each data byte, the TAS5558 responds with an acknowledge bit.

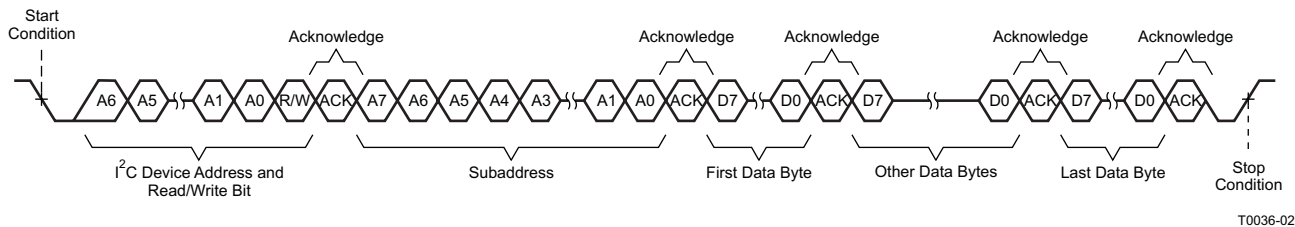

Figure 8-3. Multiple-Byte Write Transfer

## 8.5 Incremental Multiple-Byte Write

The I<sup>2</sup>C supports a special mode which permits I<sup>2</sup>C write operations to be broken up into multiple data write operations that are multiples of four data bytes. These are 6-byte, 10-byte, 14-byte, 18-byte, etc., write operations that are composed of a device address, read/write bit, subaddress, and any multiple of four bytes of data. This permits the system to write large register values incrementally without blocking other I<sup>2</sup>C transactions.

This feature is enabled by the append subaddress function in the TAS5558. This function enables the TAS5558 to append four bytes of data to a register that was opened by a previous I<sup>2</sup>C register write operation but has not received its complete number of data bytes. Because the length of the long registers is a multiple of four bytes, using four-byte transfers has only an integral number of append operations.

When the correct number of bytes has been received, the TAS5558 begins processing the data.

The procedure to perform an incremental multibyte-write operation is as follows:

1. Start a normal I<sup>2</sup>C write operation by sending the device address, write bit, register subaddress, and the first four bytes of the data to be written. At the end of that sequence, send a stop condition. At this point, the register has been opened and accepts the remaining data that is sent by writing four-byte blocks of data to the append subaddress (0xFE).
2. At a later time, one or more append data transfers are performed to incrementally transfer the remaining number of bytes in sequential order to complete the register write operation. Each of these append operations is composed of the device address, write bit, append subaddress (0xFE), and four bytes of data followed by a stop condition.
3. The operation is terminated due to an error condition, and the data is flushed:
  - (a) If a new subaddress is written to the TAS5558 before the correct number of bytes are written.
  - (b) If more or fewer than four bytes are data written at the beginning or during any of the append operations.
  - (c) If a read bit is sent.

### 8.6 Single-Byte Read

As shown in Figure 8-4, a single-byte, data-read transfer begins with the master device transmitting a start condition followed by the I<sup>2</sup>C device address and the read/write bit. For the data-read transfer, both a write and then a read are actually performed. Initially, a write is performed to transfer the address byte or bytes of the internal memory address to be read. As a result, the read/write bit is a 0. After receiving the TAS5558 address and the read/write bit, the TAS5558 responds with an acknowledge bit. In addition, after sending the internal memory address byte or bytes, the master device transmits another start condition followed by the TAS5558 address and the read/write bit again. This time the read/write bit is a 1, indicating a read transfer. After receiving the TAS5558 address and the read/write bit, the TAS5558 again responds with an acknowledge bit. Next, the TAS5558 transmits the data byte from the memory address being read. After receiving the data byte, the master device transmits a not-acknowledge followed by a stop condition to complete the single-byte, data-read transfer.

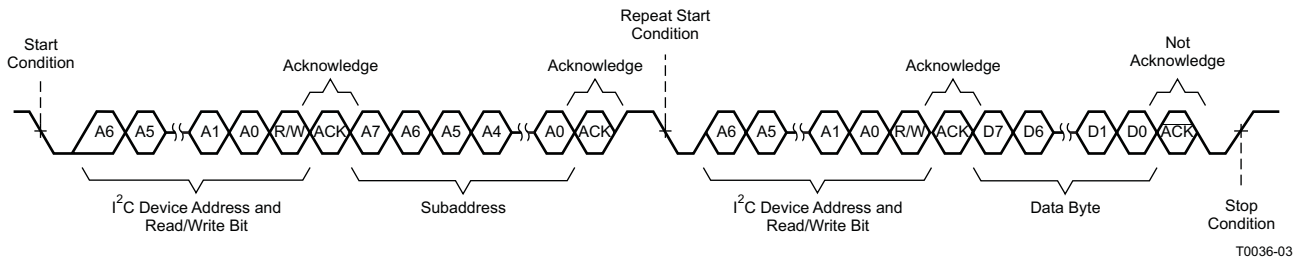

Figure 8-4. Single-Byte Read Transfer

### 8.7 Multiple-Byte Read

A multiple-byte, data-read transfer is identical to a single-byte, data-read transfer except that multiple data bytes are transmitted by the TAS5558 to the master device, as shown in Figure 8-5. Except for the last data byte, the master device responds with an acknowledge bit after receiving each data byte.

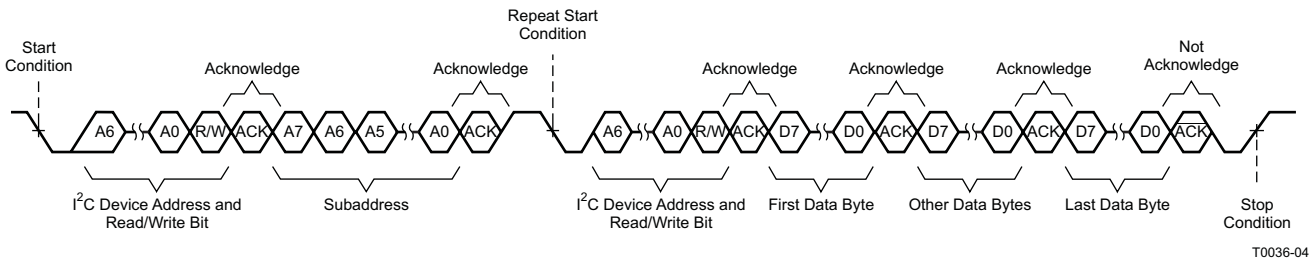

Figure 8-5. Multiple-Byte Read Transfer



## 9 Application Recommendations / Settings

### 9.1 Device System Diagrams

Typical applications for the TAS5558 are 6- to 8-channel audio systems such as DVD or AV receivers. Figure 9-1 shows the basic system diagram of the DVD receiver.

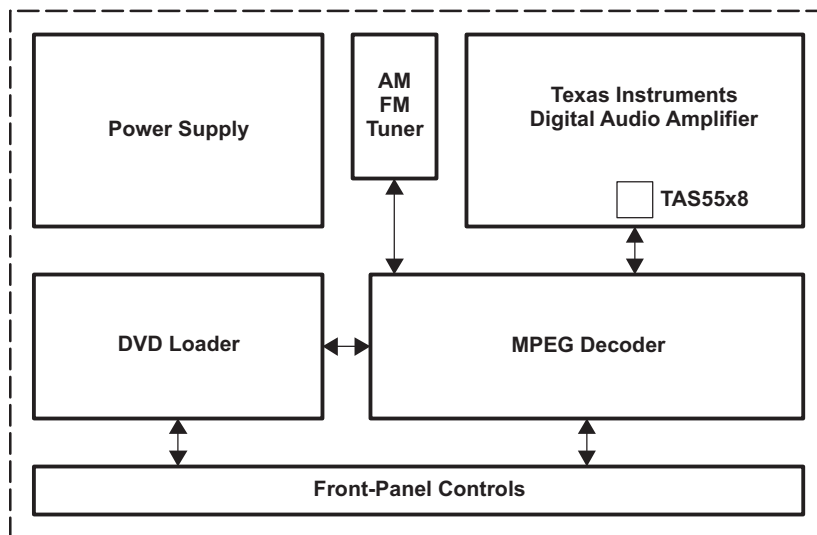

B0012-03

Figure 9-1. Typical TAS5558 Application (DVD Receiver)

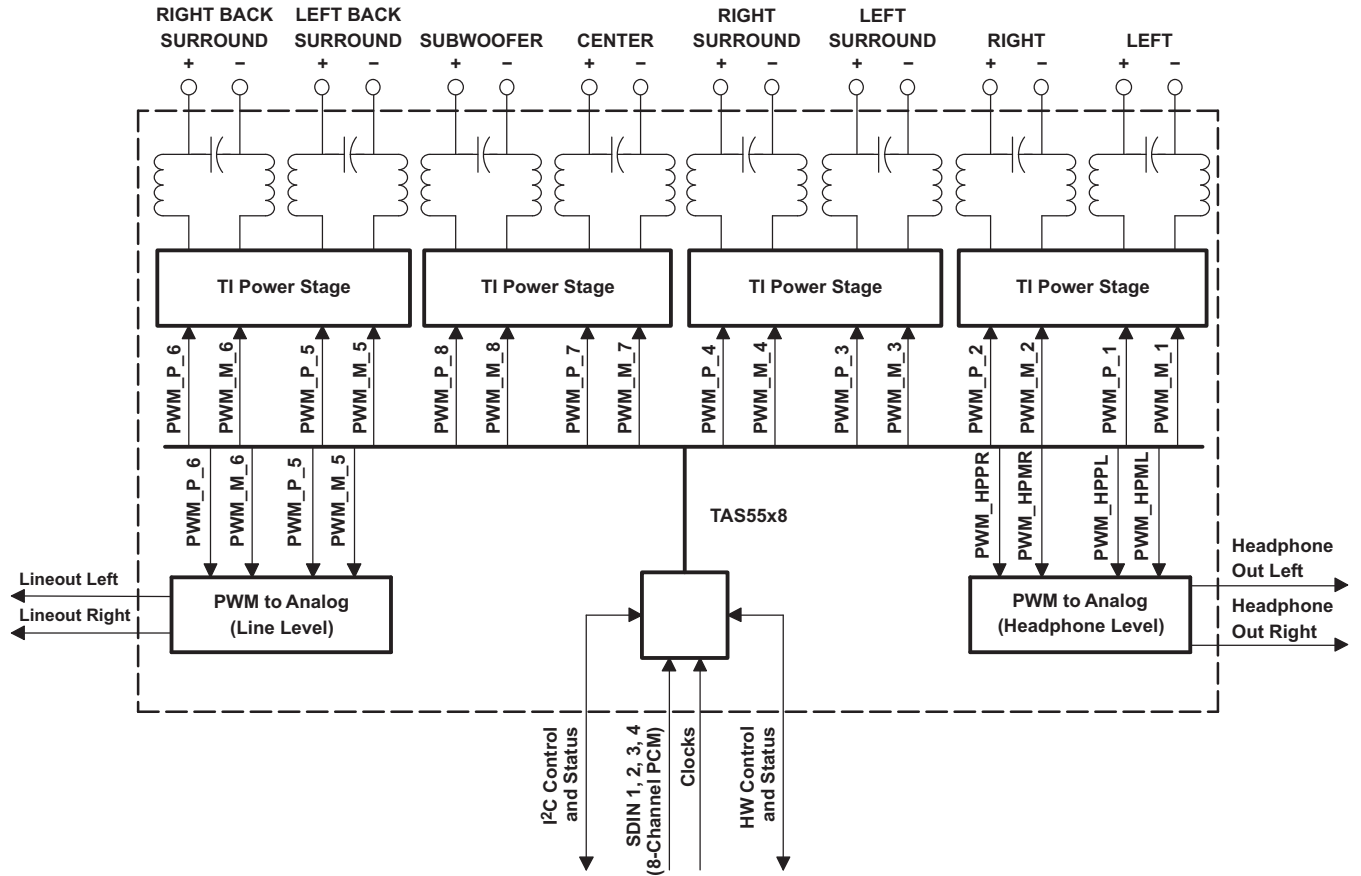

B0013-03

Figure 9-2. Pass-Through Output Mixer TAS5558 Channel Configuration

## 9.2 Serial Port Master/Slave Configurations

The inputs to the Digital Audio Processor (DAP) come from the Asynchronous Sample Rate Converter block as follows:

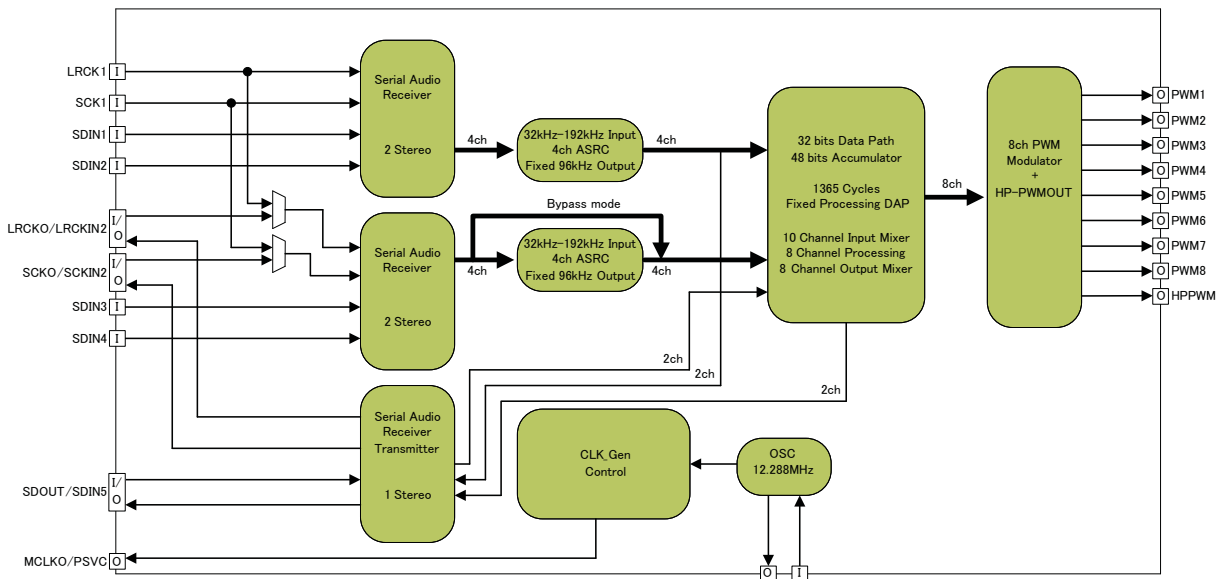

Figure 9-3. Digital Audio Signal Flow Block Diagram

The DAP can feed audio data to and from the Serial Audio ports in the following manner. There are 3 main use cases:

1. **Use Case 1: External Karaoke Microphone Input (ADC in on SDIN5) or External I2S Subwoofer**
  - (a) SDIN1 through 4 are slave to an external source (such as a media decoder IC).
  - (b) A separate DOUT (for Sub) or Microphone Inout (SDIN5) needs to function at the post-ASRC rate.
  - (c) Therefore, the device is configured to use MCLKO, SCLKO and LRCLKO.
2. **Use Case 2: Mixing two different data sources (e.g. Stereo Bluetooth I2S and CD/Media Decoder)**
  - (a) In an example where two different data sources need mixing, SDIN1/2 run at a different rate than SDIN3/4
  - (b) SCLKIN-2 and LRCLKIN-2 are used to provide an LRCLK and SCLK for the second data synchronous data source.
  - (c) DOUT (for a wireless sub) cannot be used in this mode, as no MCLKO, SCLKO or LRCLKO are available.
3. **Use Case 3: Creating an external loop for processing (e.g. using a TAS3108 or TAS3152 I2S processor)**
  - (a) SDIN1/2 run with SCLK and LRCLK as a slave.
  - (b) SDOUT acts as a "send for external processing", in master mode, synchronized to MCLKO, SCLKO, LRCLKO
  - (c) SDIN3/4 Act as a "return from external processing", in master mode, synchronized to MCLKO, SCLKO, LRCLKO

**Table 9-1. Master/Slave Serial Audio Receiver/Transmitter**

	Slave Serial Audio port	Master Serial Audio port
Use case-1	<ul style="list-style-type: none"> <li>To ASRC1 and ASRC2                             <ul style="list-style-type: none"> <li>– SCLK LRCLK</li> <li>– Synchronous data                                     <ul style="list-style-type: none"> <li>• SDIN1</li> <li>• SDIN2</li> <li>• SDIN3</li> <li>• SDIN4</li> </ul> </li> </ul> </li> </ul>	<ul style="list-style-type: none"> <li>• MCLKO</li> <li>• SCLKO</li> <li>• LRCLKO</li> <li>• Synchronous data                             <ul style="list-style-type: none"> <li>– SDIN5(mic) or SDOUT</li> </ul> </li> </ul>
Use case-2	<ul style="list-style-type: none"> <li>To ASRC1                             <ul style="list-style-type: none"> <li>– SCLK</li> <li>– LRCLK</li> <li>– Synchronous data                                     <ul style="list-style-type: none"> <li>• SDIN1</li> <li>• SDIN2</li> </ul> </li> </ul> </li> <li>To ASRC2                             <ul style="list-style-type: none"> <li>– SCLKIN-2</li> <li>– LRCLKIN-2</li> <li>– Synchronous data                                     <ul style="list-style-type: none"> <li>• SDIN2-1</li> <li>• SDIN2-2</li> </ul> </li> </ul> </li> </ul>	None of Master
Use case-3	<ul style="list-style-type: none"> <li>To ASRC1                             <ul style="list-style-type: none"> <li>– SCLK</li> <li>– LRCLK</li> <li>– Synchronous data                                     <ul style="list-style-type: none"> <li>• SDIN1</li> <li>• SDIN2</li> </ul> </li> </ul> </li> </ul>	<ul style="list-style-type: none"> <li>• MCLKO</li> <li>• SCLKO</li> <li>• LRCLKO</li> <li>• Synchronous data                             <ul style="list-style-type: none"> <li>– SDIN2-1 (ASRC2)</li> <li>– SDIN2-2 (ASRC2)</li> <li>– SDIN5 or SDOUT</li> </ul> </li> </ul>

By using use case-3, TAS5558 can connect TAS3108 as external co-processor as follows:

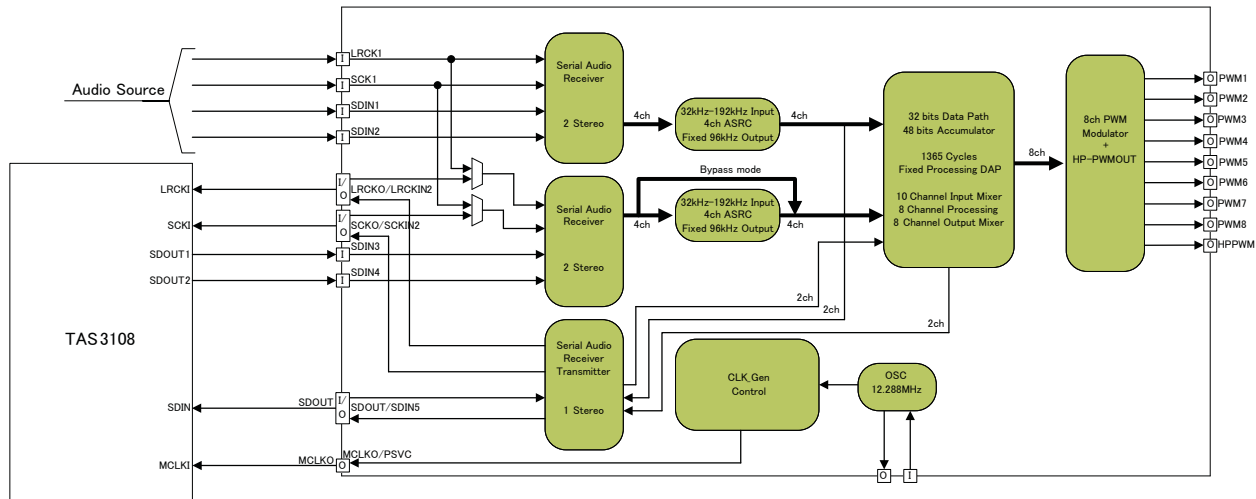

**Figure 9-4. TAS3108 as External Co-processor**

### 9.3 Startup Register Writes to get Audio Functioning

By default, the device starts up with its outputs muted. The following writes should be used to bring it out of standby

#### TAS5558

1. Trim Register 0x12 = 00 (selects the internal factory trim)
2. Exit Shutdown 0x03 = A0
3. Set Master Volume 0xD9 = 00 00 00 48

## 10 Serial-Control I<sup>2</sup>C Register Summary

The TAS5558 slave write address is 0x36 and the read address is 0x37. See *Serial-Control Interface Register Definitions*, [Section 11](#) for complete bit definitions.

Note: Default stat is read immediately after device reset.

I <sup>2</sup> C SUBADDRESS	TOTAL BYTES	REGISTER FIELDS	DESCRIPTION OF CONTENTS	DEFAULT STATE (hex)
0x01	1	General status register	ID code for the TAS5558	04
0x02	1	Error status register	CLIP and frame slip errors	00
0x03	1	System control register 1	PWM high pass, clock set, unmute select, PSVC select	B0
0x04	1	System control register 2	Automute, Shutdown, Line out, SDOUT	03
0x05–0x0C	1/reg.	Channel configuration control registers	Configure channels 1, 2, 3, 4, 5, 6, 7, and 8	E0
0x0D	1	Headphone configuration control register	Configure headphone output	00
0x0E	1	Serial data interface control register	Set serial data interface to right-justified, I <sup>2</sup> S, or left-justified.	55
0x0F	1	Soft mute register	Soft mute for channels 1, 2, 3, 4, 5, 6, 7, and 8	00
0x10	1	Energy Managers Register	See <a href="#">Table 11-10</a>	0A
0x11	1	Reserved	Do not Read or Write	RESERVED
0x12	1	Oscillator Trim	See	82
0x13	1	Reserved	Do not Read or Write	RESERVED
0x14	1	Automute control register	Set automute delay and threshold	44
0x15	1	Automute PWM threshold and back-end reset period register	Set PWM automute threshold; set back-end reset period	02
0x16	1	Modulation Limit Reg (ch1 and 2)	Set modulation index ch1 and ch2	77
0x17	1	Modulation Limit Reg (ch3 and 4)	Set Modulation Index ch3 and ch4	77
0x18	1	Modulation Limit Reg (ch5 and 6)	Set Modulation Index ch5 and ch6	77
0x19	1	Modulation Limit Reg (ch7 and 8)	Set Modulation Index ch7 and ch8	77
0x1A	1	Reserved	Do not Read or Write	RESERVED
0x1B	1	IC Delay Channel 0	See <a href="#">Table 11-15</a>	80
0x1C	1	IC Delay Channel 1	See <a href="#">Table 11-15</a>	00
0x1D	1	IC Delay Channel 2	See <a href="#">Table 11-15</a>	C0
0x1E	1	IC Delay Channel 3	See <a href="#">Table 11-15</a>	40
0x1F	1	IC Delay Channel 4	See <a href="#">Table 11-15</a>	A0
0x20	1	IC Delay Channel 5	See <a href="#">Table 11-15</a>	20
0x21	1	IC Delay Channel 6	See <a href="#">Table 11-15</a>	E0
0x22	1	IC Delay Channel 7	See <a href="#">Table 11-15</a>	60
0x23	1	IC Offset Delay Reg	See <a href="#">Table 11-15</a>	00
0x24	1	PWM sequence timing	See	0F
0x25	1	PWM and Energy Manager Control Register	See <a href="#">Table 11-17</a>	80
0x26	1	Reserved	Do not Read or Write	RESERVED
0x27	1	Individual Channel Shutdown	See <a href="#">Table 11-18</a>	00
0x28–0x2F	1	Reserved	Do not Read or Write	RESERVED
0x30	1	Input_Mux_ch1 and 2	See <a href="#">Table 11-19</a> and <a href="#">Table 11-20</a>	01
0x31	1	Input_Mux_ch3 and 4	See <a href="#">Table 11-19</a> and <a href="#">Table 11-20</a>	23
0x32	1	Input_Mux_ch5 and 6	See <a href="#">Table 11-19</a> and <a href="#">Table 11-20</a>	45
0x33	1	Input_Mux_ch7 and 8	See <a href="#">Table 11-19</a> and <a href="#">Table 11-20</a>	67

I <sup>2</sup> C SUBADDRESS	TOTAL BYTES	REGISTER FIELDS	DESCRIPTION OF CONTENTS	DEFAULT STATE (hex)
0x34	1	PWM_mux_ch1 and 2	See <a href="#">Table 11-21</a> and <a href="#">Table 11-22</a>	01
0x35	1	PWM_mux_ch3 and 4	See <a href="#">Table 11-21</a> and <a href="#">Table 11-22</a>	23
0x36	1	PWM_mux_ch5 and 6	See <a href="#">Table 11-21</a> and <a href="#">Table 11-22</a>	45
0x37	1	PWM_mux_ch7 and 8	See <a href="#">Table 11-21</a> and <a href="#">Table 11-22</a>	67
0x38	1	IC Delay Channel 0(BD Mode)	See <a href="#">Section 11.20</a>	80
0x39	1	IC Delay Channel 1(BD Mode)	See <a href="#">Section 11.20</a>	00
0x3A	1	IC Delay Channel 2(BD Mode)	See <a href="#">Section 11.20</a>	C0
0x3B	1	IC Delay Channel 3(BD Mode)	See <a href="#">Section 11.20</a>	40
0x3C	1	IC Delay Channel 4(BD Mode)	See <a href="#">Section 11.20</a>	A0
0x3D	1	IC Delay Channel 5(BD Mode)	See <a href="#">Section 11.20</a>	20
0x3E	1	IC Delay Channel 6(BD Mode)	See <a href="#">Section 11.20</a>	E0
0x3F	1	IC Delay Channel 7(BD Mode)	See <a href="#">Section 11.20</a>	60
0x40	4	<a href="#">Bank Switching command register</a>	<a href="#">Set up DAP coefficients bank switching for banks 1, 2, and 3</a>	RESERVED
0x41–0x48	32/reg.	Input mixer registers, Ch1–Ch8	8x8 input crossbar mixer setup	41 – 80 2nd Byte – Other 00 42 – 80 6th Byte – Other 00 43 – 80 10th Byte – Other 00 44 – 80 14th Byte – Other 00 45 – 80 18th Byte – Other 00 46 – 80 22nd Byte – Other 00 47 – 80 26th Byte – Other 00 48 – 80 30th Byte – Other 00
0x49	4	Bass Mixer	Input mixer 1 to Ch8 mixer coefficient	0000 0000
0x4A	4	Bass Mixer	Input mixer 2 to Ch8 mixer coefficient	0000 0000
0x4B	4	Bass Mixer	Input mixer 7 to Ch2 mixer coefficient	0000 0000
0x4C	4	Bass Mixer	Bypass Ch7 biquad 2 coefficient	0000 0000
0x4D	4	Bass Mixer	Ch7 biquad 2 coefficient	0080 0000
0x4E	4	Bass Mixer	Ch8 biquad 2 output to Ch1 mixer and Ch2 mixer coefficient	0000 0000
0x4F	4	Bass Mixer	Bypass Ch8 biquad 2 coefficient	0000 0000
0x50	4	Bass Mixer	Ch8 biquad 2 coefficient	0080 0000
0x51–0x88	20/reg.	Biquad filter register	Ch1–Ch8 biquad filter coefficients	All biquads = 80 2nd byte – other 00
0x89–0x90	8	Bass and treble register, Ch1–Ch8	Bass and treble for Ch1–Ch8	Bass and treble = 80 2nd byte – other 00
0x91	4	Loudness Log2 LG	Loudness Log2 gain (LG)	0FC0 0000
0x92	8	Loudness Log2 LO	Loudness Log2 offset (LO)	0000 0000
0x93	4	Loudness G	Loudness Gain	0000 0000
0x94	4	Loudness O	Loudness Offset	0000 0000
0x95	20	Loudness biquad	Loudness biquad coefficient b0	00FE 5045
			Loudness biquad coefficient b1	0F81 AA27
			Loudness biquad coefficient b2	0000 D513
			Loudness biquad coefficient a0	0000 0000
			Loudness biquad coefficient a1	0FFF 2AED
0x96	4	DRC1 control Ch1–Ch7	DRC1 control Ch1–Ch7	00 00 00 00
0x97	4	DRC2 control register, Ch8	DRC2 control Ch8	00 00 00 00
0x98	8	Ch1–Ch7, DRC1 energy	DRC1 energy	0000 883F 007F 77C0
		Ch1–Ch7, DRC1 (1 – energy)	DRC1 (1 – energy)	

$\mu$ C SUBADDRESS	TOTAL BYTES	REGISTER FIELDS	DESCRIPTION OF CONTENTS	DEFAULT STATE (hex)
0x99	8	Ch1–Ch7 DRC1 threshold T1	DRC1 threshold (T1) – 4 bytes	0B20 E2B2 06F9 DE58
		Ch1–Ch7 DRC1 threshold T2	DRC1 threshold (T2) – 4 bytes	
0x9A	12	Ch1–Ch7 , DRC1 slope k0	DRC1 slope (k0)	0040 0000 0FC0 0000 0F90 0000
		Ch1–Ch7, DRC1 slope k1	DRC1 slope (k1)	
		Ch1–Ch7 DRC1 slope k2	DRC1 slope (k2)	
0x9B	8	Ch1–Ch7 DRC1 offset 1	DRC1 offset 1 (O1) – 4 bytes	FF82 3098 0195 B2C0
		Ch1–Ch7 DRC1 offset 2	DRC1 offset 2 (O2) – 4 bytes	
0x9C	16	Ch1–Ch7 DRC1 attack	DRC1 attack	0000 883F 007F 77C0 0000 0056 003F FFA8
		Ch1–Ch7 DRC1 (1 – attack)	DRC1 (1 – attack)	
		Ch1–Ch7 DRC1 decay	DRC1 decay	
		Ch1–Ch7 DRC1 (1 – decay)	DRC1 (1 – decay)	
0x9D	8	Ch8 DRC2 energy	DRC2 energy	0000 883F 007F 77C0
		Ch8 DRC2 (1 – energy)	DRC2 (1 – energy)	
0x9E	8	Ch8 DRC2 threshold T1	DRC2 threshold (T1) – 4 bytes	0B20 E2B2 06F9 DE58
		Ch8 DRC2 threshold T2	DRC2 threshold (T2) – 4 bytes	
0x9F	12	Ch8 DRC2 slope k0	DRC2 slope (k0)	0040 0000 0FC0 0000 0F90 0000
		Ch8 DRC2 slope k1	DRC2 slope (k1)	
		Ch8 DRC2 slope k2	DRC2 slope (k2)	
0xA0	8	Ch8 DRC2 offset 1	DRC2 offset (O1) – lower 4 bytes	FF82 3098 0195 B2C0
		Ch8 DRC2 offset 2	DRC2 offset (O2) – lower 4 bytes	
0xA1	16	Ch8 DRC2 attack	DRC 2 attack	0000 883F 007F 77C0 0000 0056 003F FFA8
		Ch8 DRC2 (1 – attack)	DRC2 (1 – attack)	
		Ch8 DRC2 decay	DRC2 decay	
		Ch8 DRC2 (1 – decay)	DRC2 (1 – decay)	
0xA2	8	DRC bypass 1	Ch1 DRC1 bypass coefficient	0080 0000 0000 0000
		DRC inline 1	Ch1 DRC1 inline coefficient	
0xA3	8	DRC bypass 2	Ch2 DRC1 bypass coefficient	0080 0000 0000 0000
		DRC inline 2	Ch2 DRC1 inline coefficient	
0xA4	8	DRC bypass 3	Ch3 DRC1 bypass coefficient	0080 0000 0000 0000
		DRC inline 3	Ch3 DRC1 inline coefficient	
0xA5	8	DRC bypass 4	Ch4 DRC1 bypass coefficient	0080 0000 0000 0000
		DRC inline 4	Ch4 DRC1 inline coefficient	
0xA6	8	DRC bypass 5	Ch5 DRC1 bypass coefficient	0080 0000 0000 0000
		DRC inline 5	Ch5 DRC1 inline coefficient	
0xA7	8	DRC bypass 6	Ch6 DRC1 bypass coefficient	0080 0000 0000 0000
		DRC inline 6	Ch6 DRC1 inline coefficient	
0xA8	8	DRC bypass 7	Ch7 DRC1 bypass coefficient	0080 0000 0000 0000
		DRC inline 7	Ch7 DRC1 inline coefficient	
0xA9	8	DRC2 bypass 8	Ch8 DRC2 bypass coefficient	0080 0000 0000 0000
		DRC2 inline 8	Ch8 DRC2 inline coefficient	
0xAA	8	Output Select and Mix to (8x2) PWM1	See	80 2nd Byte – Other 00
0xAB	8	Output Select and Mix to (8x2) PWM2	See	10 80 1st Two Bytes – Other 00
0xAC	8	Output Select and Mix to (8x2) PWM3	See	20 80 1st Two Bytes – Other 00
0xAD	8	Output Select and Mix to (8x2) PWM4	See	30 80 1st Two Bytes – Other 00
0xAE	8	Output Select and Mix to (8x2) PWM5	See	40 80 1st Two Bytes – Other 00
0xAF	8	Output Select and Mix to (8x2) PWM6	See	50 80 1st Two Bytes – Other 00



I <sup>2</sup> C SUBADDRESS	TOTAL BYTES	REGISTER FIELDS	DESCRIPTION OF CONTENTS	DEFAULT STATE (hex)
0xB0	12	Output Select and Mix to (8x3) PWM7	See	60 80 1st Two Bytes – Other 00
0xB1	12	Output Select and Mix to (8x3) PWM8	See	70 80 1st Two Bytes – Other 00
0xB2	16	Energy Manager Averaging coefficients(Two 28 bit coefficients for satellite and sub-woofer)	sat_channels_alpha[31:0], sat_channels_1-alpha[31:0] sub_channel_alpha[31:0], sub_channels_1-alpha[31:0]	0000 0000 0000 0000 0000 0000 0000 0000
0xB3	4	Energy Manager Weighting co-efficients(28-bit coefficient for channel1)	5.23 format	0000 0000
0xB4	4	Energy Manager Weighting co-efficients(28-bit coefficient for channel2)	5.23 format	0000 0000
0xB5	4	Energy Manager Weighting co-efficients(28-bit coefficient for channel3)	5.23 format	0000 0000
0xB6	4	Energy Manager Weighting co-efficients(28-bit coefficient for channel4)	5.23 format	0000 0000
0xB7	4	Energy Manager Weighting co-efficients(28-bit coefficient for channel5)	5.23 format	0000 0000
0xB8	4	Energy Manager Weighting co-efficients(28-bit coefficient for channel6)	5.23 format	0000 0000
0xB9	4	Energy Manager Weighting co-efficients(28-bit coefficient for channel7)	5.23 format	0000 0000
0xBA	4	Energy Manager 2 Weighting co-efficient(28-bit coefficient for channel8 - Sub)	5.23 format	0000 0000
0xBB	4	Energy Manager high threshold for satellite	5.23 format	0000 0000
0xBC	4	Energy Manager low threshold for satellite	5.23 format	0000 0000
0xBD	4	Energy Manager high threshold for sub-woofer	5.23 format	0000 0000
0xBE	4	Energy Manager low threshold for sub-woofer	5.23 format	0000 0000
0xBF–0xC2	4	Reserved	Do not Read or Write	RESERVED
0xC3	4	ASRC Status	Read Only Status of both SRC banks (Lock, Mute, Error etc)	1105 0001
0xC4	4	ASRC Control	Mode Control, ASRC Control Link, Mute, Bypass, Dither etc	0001 0055
0xC5	4	ASRC Mode Control	ASRC Pin, Rate	0000 0000
0xC6	4	Reserved	Do not Read or Write	0000 0000
0xC7	8	Reserved	Do not Read or Write	0000 0000 0000 0000
0xC8	4	Reserved	Do not Read or Write	0000 0000
0xC9	4	Reserved	Do not Read or Write	0000 0000
0xCA	8	Reserved	Do not Read or Write	0000 0000 0000 0000
0xCB	4	Reserved	Do not Read or Write	0000 0000
0xCC	4	Auto Mute Behaviour	See	TBD
0xCD	4	Reserved	Do not Read or Write	RESERVED
0xCF	20	PSVC Volume biquad	PSVC Volume biquad	80 2nd Byte – Other 00
0xD0	4	Volume, treble, and bass slew rates register	Gain Adjust Rate	0000 013F
0xD1	4	Ch1 volume	Ch1 volume	0000 0048
0xD2	4	Ch2 volume	Ch2 volume	0000 0048
0xD3	4	Ch3 volume	Ch3 volume	0000 0048
0xD4	4	Ch4 volume	Ch4 volume	0000 0048

I <sup>2</sup> C SUBADDRESS	TOTAL BYTES	REGISTER FIELDS	DESCRIPTION OF CONTENTS	DEFAULT STATE (hex)
0xD5	4	Ch5 volume	Ch5 volume	0000 0048
0xD6	4	Ch6 volume	Ch6 volume	0000 0048
0xD7	4	Ch7 volume	Ch7 volume	0000 0048
0xD8	4	Ch8 volume	Ch8 volume	0000 0048
0xD9	4	Master volume	Master volume	0000 0245
0xDA	4	Bass filter set register	Bass filter set (all channels)	0303 0303
0xDB	4	Bass filter index register	Bass filter level (all channels)	1212 1212
0xDC	4	Treble filter set register	Treble filter set (all channels)	0303 0303
0xDD	4	Treble filter index register	Treble filter level (all channels)	1212 1212
0xDE	4	AM mode register	Set up AM mode for AM-interference reduction	0000 0000
0xDF	4	PSVC range register	Set PSVC control range	0000 0002
0xE0	4	General control register	6- or 8-channel configuration, PSVC enable	0000 0000
0xE1	4	Reserved	Do not Read or Write	N/A
0xE2	12	Reserved	Do not Read or Write	N/A
0xE3	4	r_dolby_COEFLR	96K Dolby Downmix 5.23. See	0029 0333
0xE4	4	r_dolby_COEFC	96K Dolby Downmix 5.23. See	001C FEEF
0xE5	4	r_dolby_COEFLSP	96K Dolby Downmix 5.23. See	001C FEEF
0xE6	4	r_dolby_COEFRSP	96K Dolby Downmix 5.23. See	001C FEEF
0xE7	4	r_dolby_COEFLSM	96K Dolby Downmix 5.23. See	0FE3 0111
0xE8	4	r_dolby_COEFRSM	96K Dolby Downmix 5.23. See	0FE3 0111
0xE9	4	THD_Manager_Pre	Boost (5.23)	0080 0000
0xEA	4	THD_Manager_Post	Cut (5.23)	0080 0000
0xEB		Reserved		N/A
0xEC	8	SDIN5 input mix L[1]	See	0000 0000 0000 0000
		SDIN5 input mix R[1]	See	0000 0000 0000 0000
0xED	8	SDIN5 input mix L[2]	See	0000 0000 0000 0000
		SDIN5 input mix R[2]	See	0000 0000 0000 0000
0xEE	8	SDIN5 input mix L[3]	See	0000 0000 0000 0000
		SDIN5 input mix R[3]	See	0000 0000 0000 0000
0xEF	8	SDIN5 input mix L[4]	See	0000 0000 0000 0000
		SDIN5 input mix R[4]	See	0000 0000 0000 0000
0xF0	8	SDIN5 input mix L[5]	See	0000 0000 0000 0000
		SDIN5 input mix R[5]	See	0000 0000 0000 0000
0xF1	8	SDIN5 input mix L[6]	See	0000 0000 0000 0000
		SDIN5 input mix R[6]	See	0000 0000 0000 0000
0xF2	8	SDIN5 input mix L[7]	See	0000 0000 0000 0000
		SDIN5 input mix R[7]	See	0000 0000 0000 0000
0xF3	8	SDIN5 input mix L[8]	See	0000 0000 0000 0000
		SDIN5 input mix R[8]	See	0000 0000 0000 0000
0xF4	16	192kHz Process Flow Output Mixer	P1_to_opmix[1] (5.23). See	0080 0000 0000 0000
		192kHz Process Flow Output Mixer	P2_to_opmix[1] (5.23). See	0000 0000 0000 0000
		192kHz Process Flow Output Mixer	P3_to_opmix[1] (5.23). See	0000 0000 0000 0000
		192kHz Process Flow Output Mixer	P4_to_opmix[1] (5.23). See	0000 0000 0000 0000

I <sup>2</sup> C SUBADDRESS	TOTAL BYTES	REGISTER FIELDS	DESCRIPTION OF CONTENTS	DEFAULT STATE (hex)
0xF5	16	192kHz Process Flow Output Mixer	P1_to_opmix[2] (5.23). See	0000 0000 0000 0000
		192kHz Process Flow Output Mixer	P2_to_opmix[2] (5.23). See	0080 0000 0000 0000
		192kHz Process Flow Output Mixer	P3_to_opmix[2] (5.23). See	0000 0000 0000 0000
		192kHz Process Flow Output Mixer	P4_to_opmix[2] (5.23). See	0000 0000 0000 0000
0xF6	16	192kHz Process Flow Output Mixer	P1_to_opmix[3] (5.23). See	0000 0000 0000 0000
		192kHz Process Flow Output Mixer	P2_to_opmix[3] (5.23). See	0000 0000 0000 0000
		192kHz Process Flow Output Mixer	P3_to_opmix[3] (5.23). See	0080 0000 0000 0000
		192kHz Process Flow Output Mixer	P4_to_opmix[3] (5.23). See	0000 0000 0000 0000
0xF7	16	192kHz Process Flow Output Mixer	P1_to_opmix[4] (5.23). See	0000 0000 0000 0000
		192kHz Process Flow Output Mixer	P2_to_opmix[4] (5.23). See	0000 0000 0000 0000
		192kHz Process Flow Output Mixer	P3_to_opmix[4] (5.23). See	0000 0000 0000 0000
		192kHz Process Flow Output Mixer	P4_to_opmix[4] (5.23). See	0080 0000 0000 0000
0xF8-0xF9	4	Reserved	Do not Read or Write	RESERVED
0xFA	4	192kHz Image Select	IMGSEL	0000 0000
0xFB	16	192kHz Dolby Downmix Coefficients	dolby_COEF1L (5.23) See	0029 0333
			dolby_COEF2L (5.23) See	001C FEEF
			dolby_COEF3L (5.23) See	FFE3 0111
			dolby_COEF4L (5.23) See	FFE3 0111
0xFC	16	192kHz Dolby Downmix Coefficients	dolby_COEF1R (5.23) See	0029 0333
			dolby_COEF2R (5.23) See	001C FEEF
			dolby_COEF3R (5.23) See	001C FEEF
			dolby_COEF4R (5.23) See	001C FEEF
0xFD	4	Reserved	Do not Read or Write	RESERVED
0xFE	4 (min)	Multiple-byte write-append register	Special register	
0xFF	4	Reserved	Do not Read or Write	RESERVED

## 11 Serial-Control Interface Register Definitions

Unless otherwise noted, the I<sup>2</sup>C register default values are in **bold** font.

Note that u indicates unused/reserved bits.

### 11.1 Clock Control Register (0x00)

**Table 11-1. Clock Control Register Format**

D7	D6	D5	D4	D3	D2	D1	D0	FUNCTION
0	0	0	–	–	–	–	–	32 kHz data rate
0	1	0	–	–	–	–	–	44.1 kHz data rate
<b>0</b>	<b>1</b>	<b>1</b>	–	–	–	–	–	48 kHz data rate
1	0	0	–	–	–	–	–	88.2 kHz data rate
1	0	1	–	–	–	–	–	<b>96 kHz data rate</b>
1	1	0	–	–	–	–	–	176.4 kHz data rate
1	1	1	–	–	–	–	–	192 kHz data rate
–	–	–	–	–	–	–	–	
–	–	–	0	0	0			MCLK frequency = 64
–	–	–	0	0	1			MCLK frequency = 128
–	–	–	0	1	0			MCLK frequency = 192
–	–	–	<b>0</b>	<b>1</b>	<b>1</b>			<b>MCLK frequency = 256</b>
–	–	–	1	0	0			MCLK frequency = 384
–	–	–	1	0	1			MCLK frequency = 512
–	–	–	1	1	0			MCLK frequency = 768
–	–	–	1	1	1			Reserved
–	–	–	–	–	–	–	–	
–	–	–	–	–	–	–	1	Clock register is valid (read-only)
–	–	–	–	–	–	<b>0</b>	<b>0</b>	<b>Clock register is not valid (read-only)</b>

### 11.2 General Status Register 0 (0x01)

**Table 11-2. General Status Register Format**

D7	D6	D5	D4	D3	D2	D1	D0	FUNCTION
<b>0</b>	<b>0</b>	<b>0</b>	<b>0</b>	<b>0</b>	<b>1</b>	<b>0</b>	<b>0</b>	Identification code for TAS5558

### 11.3 Error Status Register (0x02)

Note that the error bits are sticky bits that are not cleared by the hardware. This means that the software must clear the register (write zeroes) and then read them to determine if there are any persistent errors. Bits D7-D4 are reserved.

**Table 11-3. Error Status Register (0x02)**

D7	D6	D5	D4	D3	D2	D1	D0	FUNCTION
–	–	–	–	1	–	–	–	Frame Slip
–	–	–	–	–	1	–	–	Clip Indicator
–	–	–	–	–	–	1	–	Faultz
<b>0</b>	<b>0</b>	<b>0</b>	<b>0</b>	<b>0</b>	<b>0</b>	<b>0</b>	<b>0</b>	<b>No Errors</b>

### 11.4 System Control Register 1 (0x03)

Bits D1 and D0 are Reserved.

**Table 11-4. System Control Register-1 Format**

D7	D6	D5	D4	D3	D2	D1	D0	Function
0	–	–	–	–	–	–	–	PWM high pass disabled
<b>1</b>	–	–	–	–	–	–	–	<b>PWM high pass enabled</b>
–	1	–	–	–	–	–	–	PSVC HIZ Enable
–	<b>0</b>	–	–	–	–	–	–	<b>PSVC HIZ Disable</b>
–	–	0	–	–	–	–	–	Soft Unmute on Recovery from Clock Error
–	–	<b>1</b>	–	–	–	–	–	<b>Hard Unmute on Recovery from Clock Error</b>
–	–	–	0	–	–	–	–	All Channel enable
–	–	–	<b>1</b>	–	–	–	–	<b>All Channel Shutdown</b>
–	–	–	–	<b>0</b>	–	–	–	<b>Enable Clock Auto Detect (Always set to 0 for correct operation)</b>
–	–	–	–	1	–	–	–	Disable Clock Auto Detect
–	–	–	–	–	<b>0</b>	–	–	<b>PWM MidZ Enable (No By-pass)</b>
–	–	–	–	–	1	–	–	PWM MidZ Bypass
–	–	–	–	–	–	<b>0</b>	<b>0</b>	<b>Reserved: Do not change B0 and B1 from 00.</b>
–	–	–	–	–	–	0	1	Reserved:
–	–	–	–	–	–	1	0	Reserved:
–	–	–	–	–	–	1	1	Reserved:

## 11.5 System Control Register 2 (0x04)

Bit D3 is reserved.

**Table 11-5. System Control Register-2 Format**

D7	D6	D5	D4	D3	D2	D1	D0	Function
0	–	–	–	–	–	–	–	Unmute Threshold 6 dB over Input Threshold
1	–	–	–	–	–	–	–	Unmute Threshold equal to Input Threshold
–	0	–	–	–	–	–	–	All channel auto-mute timeout disable
–	1	–	–	–	–	–	–	All channel auto-mute timeout enable
–	–	0	–	–	–	–	–	Disable channel group
–	–	1	–	–	–	–	–	Enable channel group
–	–	–	0	–	–	–	–	Enable DAP automute
–	–	–	1	–	–	–	–	Disable DAP automute
–	–	–	–	0	0	–	–	Normal Mode
–	–	–	–	–	1	–	–	Line out Mode
–	–	–	–	–	–	1	–	ASEL_EMO2 pin is input
–	–	–	–	–	–	0	–	ASEL_EMO2 pin is out output
–	–	–	–	–	–	–	0	No Output Downmix on SDOUT(TX SAP Disable)
–	–	–	–	–	–	–	1	Output Downmix on SDOUT. Dolby-out is enabled when this bit is set and system is in normal mode

## 11.6 Channel Configuration Control Registers (0x05–0x0C)

Channels 1, 2, 3, 4, 5, 6, 7, and 8 are mapped into 0x05, 0x06, 0x07, 0x08, 0x09, 0x0A, 0x0B, and 0x0C, respectively.

**Table 11-6. Channel Configuration Control Register Format**

D7	D6	D5	D4	D3	D2	D1	D0	FUNCTION
0	–	–	–	–	–	–	–	Disable back-end reset sequence if all channels set to disable.
1	–	–	–	–	–	–	–	Enable back-end reset sequence.
–	0	–	–	–	–	–	–	RESERVED
–	1	–	–	–	–	–	–	RESERVED
–	–	0	–	–	–	–	–	RESERVED
–	–	1	–	–	–	–	–	RESERVED
–	–	–	0	–	–	–	–	Normal Back-End Polarity
–	–	–	1	–	–	–	–	Switches PWM+ and PWM– and inverts audio signal
–	–	–	–	0	–	–	–	RESERVED
–	–	–	–	1	–	–	–	RESERVED
–	–	–	–	–	0	–	–	RESERVED
–	–	–	–	–	1	–	–	RESERVED
–	–	–	–	–	–	0	–	RESERVED
–	–	–	–	–	–	1	–	RESERVED

## 11.7 Headphone Configuration Control Register (0x0D)

Bit D0 is *don't care*.

**Table 11-7. Headphone Configuration Control Register Format**

D7	D6	D5	D4	D3	D2	D1	D0	FUNCTION
0	–	–	–	–	–	–	–	Disable back-end reset sequence for Headphone
1	–	–	–	–	–	–	–	Enable back-end reset sequence for Headphone
–	0	–	–	–	–	–	–	Valid is high when headphone PWM outputs are switching
–	1	–	–	–	–	–	–	Valid low in Headphone mode.
–	–	0	–	–	–	–	–	Reserved
–	–	1	–	–	–	–	–	Reserved
–	–	–	0	–	–	–	–	Reserved
–	–	–	1	–	–	–	–	Reserved
–	–	–	–	0	–	–	–	Reserved
–	–	–	–	1	–	–	–	Reserved
–	–	–	–	–	0	–	–	Reserved
–	–	–	–	–	1	–	–	Reserved
–	–	–	–	–	–	0	–	Reserved
–	–	–	–	–	–	–	1	Reserved

## 11.8 Serial Data Interface Control Register (0x0E)

Nine serial modes can be programmed via the I<sup>2</sup>C interface.

**Table 11-8. Serial Data Interface Control Register Format for SDOUT and SDIN5**

SERIAL DATA INTERFACE FORMAT	WORD LENGTHS	D3	D2	D1	D0
Right-justified	16	0	0	0	0
Right-justified	20	0	0	0	1
Right-justified	24	0	0	1	0
I <sup>2</sup> S	16	0	0	1	1
I <sup>2</sup> S	20	0	1	0	0
<b>I<sup>2</sup>S</b>	<b>24</b>	<b>0</b>	<b>1</b>	<b>0</b>	<b>1</b>
Left-justified	16	0	1	1	0
Left-justified	20	0	1	1	1
Left-justified	24	1	0	0	0
Illegal		1	0	0	1
Illegal		1	0	1	0
Illegal		1	0	1	1
Illegal		1	1	0	0
Illegal		1	1	0	1
Illegal		1	1	1	0
Illegal		1	1	1	1

## 11.9 Soft Mute Register (0x0F)

Do not use this register if using the remapped output mixer configuration.

**Table 11-9. Soft Mute Register Format**

D7	D6	D5	D4	D3	D2	D1	D0	FUNCTION
–	–	–	–	–	–	–	1	Soft mute channel 1
–	–	–	–	–	–	1	–	Soft mute channel 2
–	–	–	–	–	1	–	–	Soft mute channel 3
–	–	–	–	1	–	–	–	Soft mute channel 4
–	–	–	1	–	–	–	–	Soft mute channel 5
–	–	1	–	–	–	–	–	Soft mute channel 6
–	1	–	–	–	–	–	–	Soft mute channel 7
1	–	–	–	–	–	–	–	Soft mute channel 8
<b>0</b>	<b>0</b>	<b>0</b>	<b>0</b>	<b>0</b>	<b>0</b>	<b>0</b>	<b>0</b>	<b>Unmute all channels</b>



### 11.10 Energy Manager Status Register (0x10)

These bits are sticky and will be cleared only when a '0' is written into these bits through I<sup>2</sup>C interface.

**Table 11-10. Energy Manager Register Format**

D7	D6	D5	D4	D3	D2	D1	D0	FUNCTION
–	–	–	–	–	–	–	<b>0</b>	<b>Energy above the low threshold for satellite channels</b>
–	–	–	–	–	–	–	1	Energy below the low threshold for satellite channels
–	–	–	–	–	–	0	–	Energy below the high threshold for satellite channels
–	–	–	–	–	–	<b>1</b>	–	<b>Energy above the high threshold for satellite channels</b>
–	–	–	–	–	<b>0</b>	–	–	<b>Energy above the low threshold for sub-woofer channels</b>
–	–	–	–	–	1	–	–	Energy below the low threshold for sub-woofer channels
–	–	–	–	0	–	–	–	Energy below the high threshold for sub-woofer channels
–	–	–	–	<b>1</b>	–	–	–	<b>Energy above the high threshold for sub-woofer channels</b>

## 11.11 Automute Control Register (0x14)

Table 11-11. Automute Control Register Format

D7	D6	D5	D4	D3	D2	D1	D0	FUNCTION
–	–	–	–	0	0	0	0	Set input automute and output automute delay to 2.98 ms
–	–	–	–	0	0	0	1	Set input automute and output automute delay to 4.47 ms
–	–	–	–	0	0	1	0	Set input automute and output automute delay to 5.96 ms
–	–	–	–	0	0	1	1	Set input automute and output automute delay to 7.45 ms
–	–	–	–	<b>0</b>	<b>1</b>	<b>0</b>	<b>0</b>	<b>Set input automute and output automute delay to 14.9 ms</b>
–	–	–	–	0	1	0	1	Set input automute and output automute delay to 29.8 ms
–	–	–	–	0	1	1	0	Set input automute and output automute delay to 44.7 ms
–	–	–	–	0	1	1	1	Set input automute and output automute delay to 59.6 ms
–	–	–	–	1	0	0	0	Set input automute and output automute delay to 74.5 ms
–	–	–	–	1	0	0	1	Set input automute and output automute delay to 89.4 ms
–	–	–	–	1	0	1	0	Set input automute and output automute delay to 104.3 ms
–	–	–	–	1	0	1	1	Set input automute and output automute delay to 119.2 ms
–	–	–	–	1	1	0	0	Set input automute and output automute delay to 134.1 ms
–	–	–	–	1	1	0	1	Set input automute and output automute delay to 149 ms
–	–	–	–	1	1	1	0	Set input automute and output automute delay to 163.9 ms
–	–	–	–	1	1	1	1	Set input automute and output automute delay to 178.8 ms
0	0	0	0	–	–	–	–	Set input automute threshold less than -90dBFS
0	0	0	1	–	–	–	–	Set input automute threshold less than -84dBFS
0	0	1	0	–	–	–	–	Set input automute threshold less than -78dBFS
0	0	1	1	–	–	–	–	Set input automute threshold less than -72dBFS
<b>0</b>	<b>1</b>	<b>0</b>	<b>0</b>	–	–	–	–	<b>Set input automute threshold less than -66dBFS</b>
0	1	0	1	–	–	–	–	Set input automute threshold less than -60dBFS
0	1	1	0	–	–	–	–	Set input automute threshold less than -54dBFS
1	1	1	1	–	–	–	–	Set input automute threshold less than -48dBFS
1	0	0	0	–	–	–	–	Set input automute threshold less than -42dBFS
1	0	0	1	–	–	–	–	RESERVED
1	0	1	0	–	–	–	–	RESERVED
1	0	1	1	–	–	–	–	RESERVED
1	1	0	0	–	–	–	–	RESERVED
1	1	0	1	–	–	–	–	RESERVED
1	1	1	0	–	–	–	–	RESERVED
1	1	1	1	–	–	–	–	RESERVED

Automute threshold are in dB with respect to a full-scale input signal. The thresholds are approximate.

## 11.12 Output Automute PWM Threshold and Back-End Reset Period Register (0x15)

For more information on how to use this register, see *Automute and Mute Channel Controls*,

**Table 11-12. Automute PWM Threshold and Back-End Reset Period Register Format**

D7	D6	D5	D4	D3	D2	D1	D0	FUNCTION
0	0	0	0	–	–	–	–	Set PWM automute threshold equal to input automute threshold
0	0	0	1	–	–	–	–	Set PWM automute threshold +6dB over input automute threshold
0	0	1	0	–	–	–	–	Set PWM automute threshold +12dB over input automute threshold
0	0	1	1	–	–	–	–	Set PWM automute threshold +18dB over input automute threshold
0	1	0	0	–	–	–	–	Set PWM automute threshold +24dB over input automute threshold
0	1	0	1	–	–	–	–	Set PWM automute threshold +30dB over input automute threshold
0	1	1	0	–	–	–	–	Set PWM automute threshold +36dB over input automute threshold
0	1	1	1	–	–	–	–	Set PWM automute threshold +42dB over input automute threshold
1	0	0	0	–	–	–	–	Set PWM automute threshold equal to input automute threshold
1	0	0	1	–	–	–	–	Set PWM automute threshold -6dB below input automute threshold
1	0	1	0	–	–	–	–	Set PWM automute threshold -12dB below input automute threshold
1	0	1	1	–	–	–	–	Set PWM automute threshold -18dB below input automute threshold
1	1	0	0	–	–	–	–	Set PWM automute threshold -24dB below input automute threshold
1	1	0	1	–	–	–	–	Set PWM automute threshold -30dB below input automute threshold
1	1	1	0	–	–	–	–	Set PWM automute threshold -36dB below input automute threshold
1	1	1	1	–	–	–	–	Set PWM automute threshold -42dB below input automute threshold
–	–	–	–	0	0	0	0	Set back-end reset period < 1 ms
–	–	–	–	0	0	0	1	Set back-end reset period 70 ms
–	–	–	–	0	0	1	0	<b>Set back-end reset period 80 ms</b>
–	–	–	–	0	0	1	1	Set back-end reset period 220 ms
–	–	–	–	0	1	0	0	Set back-end reset period 360 ms
–	–	–	–	0	1	0	1	Set back-end reset period 500 ms
–	–	–	–	0	1	1	0	Set back-end reset period 660 ms
–	–	–	–	0	1	1	1	Set back-end reset period 800 ms
–	–	–	–	1	0	0	0	Set back-end reset period 940 ms
–	–	–	–	1	0	0	1	Set back-end reset period 1080 ms
–	–	–	–	1	0	1	0	Set back-end reset period 1220 ms
–	–	–	–	1	0	1	1	Set back-end reset period 1220 ms
–	–	–	–	1	1	X	X	Set back-end reset period 1220 ms

PWM Automute is in dB with respect to Input Automute Threshold. The Thresholds are approximate.

### 11.13 Modulation Index Limit Register (0x16, 0x17, 0x18, 0x19)

Note that some power stages require a lower modulation limit than the default of 93.7%. Contact Texas Instruments for more details about the requirements for a particular power stage.

**Table 11-13. Modulation Limit Register Format**

Di+3	Di+2	Di+1	Di (i=0 or 4)	LIMIT [DCLKs]	MIN WIDTH [DCLKs]	MODULATION INDEX
0	0	0	0	1	2	99.21%
0	0	0	1	2	4	98.43%
0	0	1	0	3	6	97.64%
0	0	1	1	4	8	96.85%
0	1	0	0	5	10	96.06%
0	1	0	1	6	12	95.28%
0	1	1	0	7	14	94.49%
<b>0</b>	<b>1</b>	<b>1</b>	<b>1</b>	<b>8</b>	<b>16</b>	<b>93.70%</b>
1	0	0	0	9	18	92.91%
1	0	0	1	10	20	92.13%
1	0	1	0	11	22	91.34%
1	0	1	1	12	24	90.55%
1	1	0	0	13	26	89.76%
1	1	0	1	14	28	88.98%
1	1	1	0	15	30	88.19%
1	1	1	1	16	32	87.40%

There are 512 DCLK Cycles per PWM frame.

**Table 11-14. Modulation Index Limit Register**

Register Address	D7	D6	D5	D4	D3	D2	D1	D0
x16	Modulation limit for channel 2				Modulation limit for channel 1			
x17	Modulation limit for channel 4				Modulation limit for channel 3			
x18	Modulation limit for channel 6				Modulation limit for channel 5			
x19	Modulation limit for channel 8				Modulation limit for channel 7			

### 11.14 AD Mode - 8 Interchannel Channel Delay and Global Offset Registers (0x1B to 0x23)

Interchannel delay is used to distribute the switching current of each channel, to ease the peak power draw on the PSU. It's also used to control the intermodulation between the channels, therefore improving THD in some cases.

DCLK is the oversampling clock of the PWM.

DCLK on the TAS5558 will be based on the MCLK Rate.

Each channel can have its channel delay set between -128 to +124. (4 DCLK steps value (-32 to +31 over 5 bits))

Channels 0, 1, 2, 3, 4, 5, 6, 7 are mapped into (0x1B, 0x1C, 0x1D, 0x1E, 0x1F, 0x20, 0x21, 0x22) with bits D[7:2] used to program individual DCLK delay. Bit D[1:0] are reserved in each register.

A Global offset can be used in register 0x23

**Table 11-15. Interchannel Delay Register Format (0x1B to 0x22)**

D7	D6	D5	D4	D3	D2	FUNCTION
0	0	0	0	0	0	Minimum absolute delay, 0 DCLK cycles
0	1	1	1	1	1	Maximum positive delay, 31(x4) DCLK cycles
1	0	0	0	0	0	Maximum Negative delay, -32(x4) DCLK cycles
1	0	0	0	0	0	Default Value for channel 0 = -128 DCLK's (-32*4)
0	0	0	0	0	0	Default Value for channel 1 = 0
1	1	0	0	0	0	Default Value for channel 2 = -64DCLK's (-16*4)
0	1	0	0	0	0	Default Value for channel 3 = 64 DCLK's (16*4)
1	0	1	0	0	0	Default Value for channel 4 = -96 DCLK's (-24*4)
0	0	1	0	0	0	Default Value for channel 5 = 32 DCLK's (8*4)
1	1	1	0	0	0	Default Value for channel 6 = -32 DCLK's (-8*4)
0	1	1	0	0	0	Default Value for channel 7 = 96 DCLK's (24*4)

**Table 11-16. Interchannel Delay Global Offset (0x23) (AD PWM Mode Only)**

D7	D6	D5	D4	D3	D2	D1	D0	FUNCTION
0	0	0	0	0	0	0	0	Minimum absolute offset, 0 DCLK cycles, Default for channel 0
1	1	1	1	1	1	1	1	Maximum absolute delay, 255 DCLK cycles

### 11.15 Special Low Z and Mid Z Ramp/Stop Period (0x24)

This is also the delay period for delayed start/stop with legacy LowZ sequences. If register 0x25 is programmed for special LowZ sequence, the time above is the PWM ramp up period. If it is programmed for MidZ, the time above is the PWM stop period.

D7	D6	D5	D4	D3	D2	D1	D0	FUNCTION
–	–	–	0	0	–	–	–	No Ramp/Stop period
–	–	–	0	1	0	0	0	14.9 ms Ramp/Stop period
–	–	–	0	1	0	0	1	22.35 ms Ramp/Stop period
–	–	–	0	1	0	1	0	29.80 ms Ramp/Stop period
–	–	–	0	1	0	1	1	38.74 ms Ramp/Stop period
–	–	–	0	1	1	0	0	52.15 ms Ramp/Stop period
–	–	–	0	1	1	0	1	68.54 ms Ramp/Stop period
–	–	–	0	1	1	1	0	92.38 ms Ramp/Stop period
–	–	–	<b>0</b>	<b>1</b>	<b>1</b>	<b>1</b>	<b>1</b>	<b>123.67 ms Ramp/Stop period</b>
–	–	–	1	0	0	0	0	149 ms Ramp/Stop period
–	–	–	1	0	0	0	1	223.5 ms Ramp/Stop period
–	–	–	1	0	0	1	0	298 ms Ramp/Stop period
–	–	–	1	0	..	..	..	...
–	–	–	1	0	1	1	1	1236.7 ms Ramp/Stop period
–	–	–	1	1	0	0	0	1490 ms Ramp/Stop period
–	–	–	1	1	0	0	1	2235 ms Ramp/Stop period
–	–	–	1	1	0	1	0	2980 ms Ramp/Stop period
–	–	–	1	1	..	..	..	...
–	–	–	1	1	1	1	1	12367 ms Ramp/Stop period

### 11.16 PWM and EMO Control Register (0x25)

Table 11-17. PWM Config, Energy Manager Reporting Register

D7	D6	D5	D4	D3	D2	D1	D0	FUNCTION
0	0	–	–	–	–	–	–	Use Legacy LowZ sequence for PWM start
<b>1</b>	<b>0</b>	–	–	–	–	–	–	<b>Use special LowZ sequence for PWM start</b>
1	1	–	–	–	–	–	–	Use MidZ sequence for external charge
		<b>0</b>	–	–	–	–	–	<b>Ternary modulation disable</b>
		1	–	–	–	–	–	Ternary modulation enable
			<b>0</b>	–	–	–	–	<b>Ternary High bias disable</b>
			1	–	–	–	–	Ternary High bias enable
				<b>0</b>	–	–	–	Energy Manager LO threshold reporting disable ← default
				1	–	–	–	<b>Energy Manager LO threshold reporting enable</b>
–	–	–	–	–	<b>0</b>	<b>0</b>	<b>0</b>	Reserved ← Default

### 11.17 Individual Channel Shutdown (0x27)

Table 11-18. Individual Channel Shutdown Register

D7	D6	D5	D4	D3	D2	D1	D0	FUNCTION
1	–	–	–	–	–	–	–	Keep channel 8 in shutdown
<b>0</b>	–	–	–	–	–	–	–	<b>Bring Channel 8 out of shutdown</b>
–	1	–	–	–	–	–	–	Keep channel 7 in shutdown
–	<b>0</b>	–	–	–	–	–	–	<b>Bring Channel 7 out of shutdown</b>
–	–	1	–	–	–	–	–	Keep channel 6 in shutdown

**Table 11-18. Individual Channel Shutdown Register (continued)**

D7	D6	D5	D4	D3	D2	D1	D0	FUNCTION
–	–	<b>0</b>	–	–	–	–	–	<b>Bring Channel 6 out of shutdown</b>
–	–	–	1	–	–	–	–	Keep channel 5 in shutdown
–	–	–	<b>0</b>	–	–	–	–	<b>Bring Channel 5 out of shutdown</b>
–	–	–	–	1	–	–	–	Keep channel 4 in shutdown
–	–	–	–	<b>0</b>	–	–	–	<b>Bring Channel 4 out of shutdown</b>
–	–	–	–	–	1	–	–	Keep channel 3 in shutdown
–	–	–	–	–	<b>0</b>	–	–	<b>Bring Channel 3 out of shutdown</b>
–	–	–	–	–	–	1	–	Keep channel 2 in shutdown
–	–	–	–	–	–	<b>0</b>	–	<b>Bring Channel 2 out of shutdown</b>
–	–	–	–	–	–	–	1	Keep channel 1 in shutdown
–	–	–	–	–	–	–	<b>0</b>	<b>Bring Channel 1 out of shutdown</b>

Individual channel shutdown register should be written prior to bringing system out of shutdown using reg 0x03 (Exit Shutdown).

### 11.18 Input Mux Registers (0x30, 0x31, 0x32, 0x33)

**Table 11-19. Input Mux Registers Format**

Register Address	Default Value	D7	D6	D5	D4	D3	D2	D1	D0
x30	<b>00000001</b>	BD/AD mode ch 1	Input Mux select for channel 1			BD/AD mode ch 2	Input Mux select for channel 2		
x31	<b>00100011</b>	BD/AD mode ch 3	Input Mux select for channel 3			BD/AD mode ch 4	Input Mux select for channel 4		
x32	<b>01000101</b>	BD/AD mode ch 5	Input Mux select for channel 5			BD/AD mode ch 6	Input Mux select for channel 6		
x33	<b>01100111</b>	BD/AD mode ch 7	Input Mux select for channel 7			BD/AD mode ch 8	Input Mux select for channel 8		

**Table 11-20. Input Mux Registers Format**

D6/D2	D5/D1	D4/D0	FUNCTION
0	0	0	Select channel 1
0	0	1	Select channel 2
0	1	0	Select channel 3
0	1	1	Select channel 4
1	0	0	Select channel 5
1	0	1	Select channel 6
1	1	0	Select channel 7
1	1	1	Select channel 8

### 11.19 PWM Mux Registers (0x34, 0x35, 0x36, 0x37)

**Table 11-21. PWM Mux Registers Format**

Register Address	Default Value	D7	D6	D5	D4	D3	D2	D1	D0
x34	<b>00000001</b>	unused	PWM Mux select for channel 1			unused	PWM Mux select for channel 2		
x35	<b>00100011</b>	unused	PWM Mux select for channel 3			unused	PWM Mux select for channel 4		
x36	<b>01000101</b>	unused	PWM Mux select for channel 5			unused	PWM Mux select for channel 6		
x37	<b>01100111</b>	unused	PWM Mux select for channel 7			unused	PWM Mux select for channel 8		

**Table 11-22. PWM Registers Format**

D6/D2	D5/D1	D4/D0	FUNCTION
0	0	0	Select channel 1
0	0	1	Select channel 2
0	1	0	Select channel 3
0	1	1	Select channel 4
1	0	0	Select channel 5
1	0	1	Select channel 6
1	1	0	Select channel 7
1	1	1	Select channel 8

**11.20 BD mode and Ternary - 8 Interchannel Channel Delay (0x38 to 0x3F)**

Interchannel delay is used to distribute the switching current of each channel, to ease the peak power draw on the PSU. It's also used to control the intermodulation between the channels, therefore improving THD in some cases.

DCLK is the oversampling clock of the PWM.

DCLK on the TAS5558 will be based on the MCLK Rate.

Each channel can have its channel delay set between -128 to +124. (4 DCLK steps value (-32 to +31 over 5 bits))

Channels 0, 1, 2, 3, 4, 5, 6, 7 are mapped into (0x38, 0x39, 0x3A, 0x3B, 0x3C, 0x3D, 0x3E, 0x3F) with bits D[7:2] used to program individual DCLK delay. Bit D[1:0] are reserved in each register.

**Table 11-23. Interchannel Delay Register Format (0x38B to 0x3F)**

D7	D6	D5	D4	D3	D2	FUNCTION
0	0	0	0	0	0	Minimum absolute delay, 0 DCLK cycles
0	1	1	1	1	1	Maximum positive delay, 31(x4) DCLK cycles
1	0	0	0	0	0	Maximum Negative delay, -32(x4) DCLK cycles
1	0	0	0	0	0	Default Value for channel 0 = -128 DCLK's (-32*4)
0	0	0	0	0	0	Default Value for channel 1 0
1	1	0	0	0	0	Default Value for channel 2 = -64DCLK's (-16*4)
0	1	0	0	0	0	Default Value for channel 3 = 64 DCLK's (16*4)
1	0	1	0	0	0	Default Value for channel 4 = -96 DCLK's (-24*4)
0	0	1	0	0	0	Default Value for channel 5 = 32 DCLK's (8*4)
1	1	1	0	0	0	Default Value for channel 6 = -32 DCLK's (-8*4)
0	1	1	0	0	0	Default Value for channel 7 = 96 DCLK's (24*4)



## 11.21 Bank-Switching Command Register (0x40) (TAS5558 + ASRC Bypass)

Bits D31–D24, D22–D19 are Reserved.

**Table 11-24. Bank-Switching Command Register Format**

D23	D22	D21	D20	D19	D18	D17	D16	FUNCTION
–	–	–	–	–	0	0	0	Manual selection bank 0
–	–	–	–	–	0	0	1	Manual selection bank 1
–	–	–	–	–	0	1	0	Manual selection bank 2
–	–	–	–	–	0	1	1	Automatic bank selection
–	–	–	–	–	1	0	0	Update the values in bank 0
–	–	–	–	–	1	0	1	Update the values in bank 1
–	–	–	–	–	1	1	0	Update the values in bank 2
0	–	–	–	–	1	1	1	Update only the bank map
0	–	–	–	–	X	X	X	Update the bank map using values in D15–D0
1	–	–	–	–	X	X	X	Do not update the bank map using values in D15–D0
D15	D14	D13	D12	D11	D10	D9	D8	FUNCTION
1	–	–	–	–	–	–	–	32-kHz data rate—use bank 0
–	1	–	–	–	–	–	–	38-kHz data rate—use bank 0
–	–	1	–	–	–	–	–	44.1-kHz data rate—use bank 0
–	–	–	1	–	–	–	–	48-kHz data rate—use bank 0
–	–	–	–	1	–	–	–	88.2-kHz data rate—use bank 0
–	–	–	–	–	1	–	–	96-kHz data rate—use bank 0
–	–	–	–	–	–	1	–	176.4-kHz data rate—use bank 0
–	–	–	–	–	–	–	1	192-kHz data rate—use bank 0
1	1	1	1	1	1	1	1	Default
D7	D6	D5	D4	D3	D2	D1	D0	FUNCTION
1	–	–	–	–	–	–	–	32-kHz data rate—use bank 1
–	1	–	–	–	–	–	–	38-kHz data rate—use bank 1
–	–	1	–	–	–	–	–	44.1-kHz data rate—use bank 1
–	–	–	1	–	–	–	–	48-kHz data rate—use bank 1
–	–	–	–	1	–	–	–	88.2-kHz data rate—use bank 1
–	–	–	–	–	1	–	–	96-kHz data rate—use bank 1
–	–	–	–	–	–	1	–	176.4-kHz data rate—use bank 1
–	–	–	–	–	–	–	1	192-kHz data rate—use bank 1
0	0	0	0	0	0	0	0	Default

## 11.22 Input Mixer Registers, Channels 1–8 (0x41–0x48)

Input mixers 1, 2, 3, 4, 5, 6, 7, and 8 are mapped into registers 0x41, 0x42, 0x43, 0x44, 0x45, 0x46, 0x47, and 0x48, respectively.

Each gain coefficient is in 28-bit (5.23) format, so 0x80 0000 is a gain of 1. Each gain coefficient is written as a 32-bit word with the upper four bits reserved. For eight gain coefficients, the total is 32 bytes.

There is no negative value available. The mixer cannot phase invert.

**Bold** indicates the one channel that is passed through the mixer.

**Table 11-25. Channel 1–8 Input Mixer Register Format**

PC SUBADDRESS	TOTAL BYTES	REGISTER FIELDS	DESCRIPTION OF CONTENTS	DEFAULT STATE
0x41	32	<b>A_to_ipmix[1]</b>	<b>SDIN1-left (Ch1) A to input mixer 1 coefficient (default = 1)</b>	<b>0080 0000</b>
		B_to_ipmix[1]	SDIN1-right (Ch2) B to input mixer 1 coefficient (default = 0)	0000 0000
		C_to_ipmix[1]	SDIN2-left (Ch3) C to input mixer 1 coefficient (default = 0)	0000 0000
		D_to_ipmix[1]	SDIN2-right (Ch4) D to input mixer 1 coefficient (default = 0)	0000 0000
		E_to_ipmix[1]	SDIN3-left (Ch5) E to input mixer 1 coefficient (default = 0)	0000 0000
		F_to_ipmix[1]	SDIN3-right (Ch6) F to input mixer 1 coefficient (default = 0)	0000 0000
		G_to_ipmix[1]	SDIN4-left (Ch7) G to input mixer 1 coefficient (default = 0)	0000 0000
		H_to_ipmix[1]	SDIN4-right (Ch8) H to input mixer 1 coefficient (default = 0)	0000 0000
0x42	32	A_to_ipmix[2]	SDIN1-left (Ch1) A to input mixer 2 coefficient (default = 0)	0000 0000
		<b>B_to_ipmix[2]</b>	<b>SDIN1-right (Ch2) B to input mixer 2 coefficient (default = 1)</b>	<b>0080 0000</b>
		C_to_ipmix[2]	SDIN2-left (Ch3) C to input mixer 2 coefficient (default = 0)	0000 0000
		D_to_ipmix[2]	SDIN2-right (Ch4) D to input mixer 2 coefficient (default = 0)	0000 0000
		E_to_ipmix[2]	SDIN3-left (Ch5) E to input mixer 2 coefficient (default = 0)	0000 0000
		F_to_ipmix[2]	SDIN3-right (Ch6) F to input mixer 2 coefficient (default = 0)	0000 0000
		G_to_ipmix[2]	SDIN4-left (Ch7) G to input mixer 2 coefficient (default = 0)	0000 0000
		H_to_ipmix[2]	SDIN4-right (Ch8) H to input mixer 2 coefficient (default = 0)	0000 0000
0x43	32	A_to_ipmix[3]	SDIN1-left (Ch1) A to input mixer 3 coefficient (default = 0)	0000 0000
		B_to_ipmix[3]	SDIN1-right (Ch2) B to input mixer 3 coefficient (default = 0)	0000 0000
		<b>C_to_ipmix[3]</b>	<b>SDIN2-left (Ch3) C to input mixer 3 coefficient (default = 1)</b>	<b>0080 0000</b>
		D_to_ipmix[3]	SDIN2-right (Ch4) D to input mixer 3 coefficient (default = 0)	0000 0000
		E_to_ipmix[3]	SDIN3-left (Ch5) E to input mixer 3 coefficient (default = 0)	0000 0000
		F_to_ipmix[3]	SDIN3-right (Ch6) F to input mixer 3 coefficient (default = 0)	0000 0000
		G_to_ipmix[3]	SDIN4-left (Ch7) G to input mixer 3 coefficient (default = 0)	0000 0000
		H_to_ipmix[3]	SDIN4-right (Ch8) H to input mixer 3 coefficient (default = 0)	0000 0000
0x44	32	A_to_ipmix[4]	SDIN1-left (Ch1) A to input mixer 4 coefficient (default = 0)	0000 0000
		B_to_ipmix[4]	SDIN1-right (Ch2) B to input mixer 4 coefficient (default = 0)	0000 0000
		C_to_ipmix[4]	SDIN2-left (Ch3) C to input mixer 4 coefficient (default = 0)	0000 0000
		<b>D_to_ipmix[4]</b>	<b>SDIN2-right (Ch4) D to input mixer 4 coefficient (default = 1)</b>	<b>0080 0000</b>
		E_to_ipmix[4]	SDIN3-left (Ch5) E to input mixer 4 coefficient (default = 0)	0000 0000
		F_to_ipmix[4]	SDIN3-right (Ch6) F to input mixer 4 coefficient (default = 0)	0000 0000
		G_to_ipmix[4]	SDIN4-left (Ch7) G to input mixer 4 coefficient (default = 0)	0000 0000
		H_to_ipmix[4]	SDIN4-right (Ch8) H to input mixer 4 coefficient (default = 0)	0000 0000

**Table 11-25. Channel 1–8 Input Mixer Register Format (continued)**

I <sup>2</sup> C SUBADDRESS	TOTAL BYTES	REGISTER FIELDS	DESCRIPTION OF CONTENTS	DEFAULT STATE
0x45	32	A_to_ipmix[5]	SDIN1-left (Ch1) A to input mixer 5 coefficient (default = 0)	0000 0000
		B_to_ipmix[5]	SDIN1-right (Ch2) B to input mixer 5 coefficient (default = 0)	0000 0000
		C_to_ipmix[5]	SDIN2-left (Ch3) C to input mixer 5 coefficient (default = 0)	0000 0000
		D_to_ipmix[5]	SDIN2-right (Ch4) D to input mixer 5 coefficient (default = 0)	0000 0000
		<b>E_to_ipmix[5]</b>	<b>SDIN3-left (Ch5) E to input mixer 5 coefficient (default = 1)</b>	<b>0080 0000</b>
		F_to_ipmix[5]	SDIN3-right (Ch6) F to input mixer 5 coefficient (default = 0)	0000 0000
		G_to_ipmix[5]	SDIN4-left (Ch7) G to input mixer 5 coefficient (default = 0)	0000 0000
		H_to_ipmix[5]	SDIN4-right (Ch8) H to input mixer 5 coefficient (default = 0)	0000 0000
0x46	32	A_to_ipmix[6]	SDIN1-left (Ch1) A to input mixer 6 coefficient (default = 0)	0000 0000
		B_to_ipmix[6]	SDIN1-right (Ch2) B to input mixer 6 coefficient (default = 0)	0000 0000
		C_to_ipmix[6]	SDIN2-left (Ch3) C to input mixer 6 coefficient (default = 0)	0000 0000
		D_to_ipmix[6]	SDIN2-right (Ch4) D to input mixer 6 coefficient (default = 0)	0000 0000
		E_to_ipmix[6]	SDIN3-left (Ch5) E to input mixer 6 coefficient (default = 0)	0000 0000
		<b>F_to_ipmix[6]</b>	<b>SDIN3-right (Ch6) F to input mixer 6 coefficient (default = 1)</b>	<b>0080 0000</b>
		G_to_ipmix[6]	SDIN4-left (Ch7) G to input mixer 6 coefficient (default = 0)	0000 0000
		H_to_ipmix[6]	SDIN4-right (Ch8) H to input mixer 6 coefficient (default = 0)	0000 0000
0x47	32	A_to_ipmix[7]	SDIN1-left (Ch1) A to input mixer 7 coefficient (default = 0)	0000 0000
		B_to_ipmix[7]	SDIN1-right (Ch2) B to input mixer 7 coefficient (default = 0)	0000 0000
		C_to_ipmix[7]	SDIN2-left (Ch3) C to input mixer 7 coefficient (default = 0)	0000 0000
		D_to_ipmix[7]	SDIN2-right (Ch4) D to input mixer 7 coefficient (default = 0)	0000 0000
		E_to_ipmix[7]	SDIN3-left (Ch5) E to input mixer 7 coefficient (default = 0)	0000 0000
		F_to_ipmix[7]	SDIN3-right (Ch6) F to input mixer 7 coefficient (default = 0)	0000 0000
		<b>G_to_ipmix[7]</b>	<b>SDIN4-left (Ch7) G to input mixer 7 coefficient (default = 1)</b>	<b>0080 0000</b>
		H_to_ipmix[7]	SDIN4-right (Ch8) H to input mixer 7 coefficient (default = 0)	0000 0000
0x48	32	A_to_ipmix[8]	SDIN1-left (Ch1) A to input mixer 8 coefficient (default = 0)	0000 0000
		B_to_ipmix[8]	SDIN1-right (Ch2) B to input mixer 8 coefficient (default = 0)	0000 0000
		C_to_ipmix[8]	SDIN2-left (Ch3) C to input mixer 8 coefficient (default = 0)	0000 0000
		D_to_ipmix[8]	SDIN2-right (Ch4) D to input mixer 8 coefficient (default = 0)	0000 0000
		E_to_ipmix[8]	SDIN3-left (Ch5) E to input mixer 8 coefficient (default = 0)	0000 0000
		F_to_ipmix[8]	SDIN3-right (Ch6) F to input mixer 8 coefficient (default = 0)	0000 0000
		G_to_ipmix[8]	SDIN4-left (Ch7) G to input mixer 8 coefficient (default = 0)	0000 0000
		<b>H_to_ipmix[8]</b>	<b>SDIN4-right (Ch8) H to input mixer 8 coefficient (default = 1)</b>	<b>0080 0000</b>

## 11.23 Bass Mixer Registers (0x49–0x50)

Registers 0x49–0x50 provide configuration control for bass management.

Each gain coefficient is in 28-bit (5.23) format, so 0x80 0000 is a gain of 1. Each gain coefficient is written as a 32-bit word with the upper four bits reserved.

There is no negative value available. The mixer cannot phase invert.

**Table 11-26. Bass Mixer Register Format**

SUB-ADDRESS	TOTAL BYTES	REGISTER NAME	DESCRIPTION OF CONTENTS	DEFAULT STATE
0x49	4	ipmix_1_to_ch8	Input mixer 1 to Ch8 mixer coefficient (default = 0) u[31:28], ipmix18[27:24], ipmix18[23:16], ipmix18[15:8], ipmix18[7:0]	0000 0000
0x4A	4	ipmix_2_to_ch8	Input mixer 2 to Ch8 mixer coefficient (default = 0) u[31:28], ipmix28[27:24], ipmix28[23:16], ipmix28[15:8], ipmix28[7:0]	0000 0000
0x4B	4	ipmix_7_to_ch12	Ch7 biquad-2 output to Ch1 mixer and Ch2 mixer coefficient (default = 0) u[31:28], ipmix72[27:24], ipmix72[23:16], ipmix72[15:8], ipmix72[7:0]	0000 0000
0x4C	4	Ch7_bp_bq2	Ch7 biquad-2 bypass coefficient (default = 0) u[31:28], ch7_bp_bq2[27:24], ch7_bp_bq2[23:16], ch7_bp_bq2[15:8], ch7_bp_bq2[7:0]	0000 0000
0x4D	4	Ch7_bq2	Ch7 biquad-2 inline coefficient (default = 1) u[31:28], ch6_bq2[27:24], ch6_bq2[23:16], ch6_bq2[15:8], ch6_bq2[7:0]	0080 0000
0x4E	4	ipmix_8_to_ch12	Ch8 biquad-2 output to Ch1 mixer and Ch2 mixer coefficient (default = 0) u[31:28], ipmix8_12[27:24], ipmix8_12[23:16], ipmix8_12[15:8], ipmix8_12[7:0]	0000 0000
0x4F	4	Ch8_bp_bq2	Ch8 biquad-2 bypass coefficient (default = 0) u[31:28], ch8_bp_bq2[27:24], ch8_bp_bq2[23:16], ch8_bp_bq2[15:8], ch8_bp_bq2[7:0]	0000 0000
0x50	4	Ch8_bq2	Ch8 biquad-2 inline coefficient (default = 1) u[31:28], ch7_bq2[27:24], ch7_bq2[23:16], ch7_bq2[15:8], ch7_bq2[7:0]	0080 0000

## 11.24 Biquad Filter Register (0x51–0x88)

**Table 11-27. Biquad Filter Register Format**

I <sup>2</sup> C SUBADDRESS	TOTAL BYTES	REGISTER NAME	DESCRIPTION OF CONTENTS	DEFAULT STATE
0x51–0x57	20/reg.	Ch1_bq[1:7]	Ch1 biquads 1–7. See <a href="#">Table 11-28</a> for bit definition.	See <a href="#">Table 11-28</a>
0x58–0x5E	20/reg.	Ch2_bq[1:7]	Ch2 biquads 1–7. See <a href="#">Table 11-28</a> for bit definition.	See <a href="#">Table 11-28</a>
0x5F–0x65	20/reg.	Ch3_bq[1:7]	Ch3 biquads 1–7. See <a href="#">Table 11-28</a> for bit definition.	See <a href="#">Table 11-28</a>
0x66–0x6C	20/reg.	Ch4_bq[1:7]	Ch4 biquads 1–7. See <a href="#">Table 11-28</a> for bit definition.	See <a href="#">Table 11-28</a>
0x6D–0x73	20/reg.	Ch5_bq[1:7]	Ch5 biquads 1–7. See <a href="#">Table 11-28</a> for bit definition.	See <a href="#">Table 11-28</a>
0x74–0x7A	20/reg.	Ch6_bq[1:7]	Ch6 biquads 1–7. See <a href="#">Table 11-28</a> for bit definition.	See <a href="#">Table 11-28</a>
0x7B–0x81	20/reg.	Ch7_bq[1:7]	Ch7 biquads 1–7. See <a href="#">Table 11-28</a> for bit definition.	See <a href="#">Table 11-28</a>
0x82–0x88	20/reg.	Ch8_bq[1:7]	Ch8 biquads 1–7. See <a href="#">Table 11-28</a> for bit definition.	See <a href="#">Table 11-28</a>

Each gain coefficient is in 28-bit (5.23) format, so 0x80 0000 is a gain of 1. Each gain coefficient is written as a 32-bit word with the upper four bits not used.

**Table 11-28. Contents of One 20-Byte Biquad Filter Register (Default = All-Pass)**

DESCRIPTION	REGISTER FIELD CONTENTS	DEFAULT GAIN COEFFICIENT VALUES	
		DECIMAL	HEX
<b>b<sub>0</sub> coefficient</b>	<b>u[31:28], b0[27:24], b0[23:16], b0[15:8], b0[7:0]</b>	<b>1.0</b>	<b>0080 0000</b>
b <sub>1</sub> coefficient	u[31:28], b1[27:24], b1[23:16], b1[15:8], b1[7:0]	0.0	0000 0000
b <sub>2</sub> coefficient	u[31:28], b2[27:24], b2[23:16], b2[15:8], b2[7:0]	0.0	0000 0000
a <sub>1</sub> coefficient	u[31:28], a1[27:24], a1[23:16], a1[15:8], a1[7:0]	0.0	0000 0000
a <sub>2</sub> coefficient	u[31:28], a2[27:24], a2[23:16], a2[15:8], a2[7:0]	0.0	0000 0000

### 11.25 Bass and Treble Register, Channels 1–8 (0x89–0x90)

Channels 1, 2, 3, 4, 5, 6, 7, and 8 are mapped into registers 0x89, 0x8A, 0x8B, 0x8C, 0x8D, 0x8E, 0x8F, and 0x90, respectively. Eight bytes are written for each channel. Each gain coefficient is in 28-bit (5.23) format, so 0x80 0000 is a gain of 1. Each gain coefficient is written as a 32-bit word with the upper four bits reserved.

**Table 11-29. Channel 1–8 Bass and Treble Bypass Register Format**

REGISTER NAME	TOTAL BYTES	CONTENTS	DEFAULT VALUE
Channel bass and treble bypass	8	Bypass	0080 0000
Channel bass and treble inline		Inline	0000 0000

### 11.26 Loudness Registers (0x91–0x95)

**Table 11-30. Loudness Register Format**

I <sup>2</sup> C SUB-ADDRESS	TOTAL BYTES	REGISTER NAME	DESCRIPTION OF CONTENTS	DEFAULT STATE
0x91	4	Loudness Log2 gain (LG)	u[31:28], LG[27:24], LG[23:16], LG[15:8], LG[7:0]	0FC0 0000
0x92	4	Loudness Log2 offset (LO)	LO[31:24], LO[23:16], LO[15:8], LO[7:0]	0000 0000
0x93	4	Loudness gain (G)	u[31:28], G[27:24], G[23:16], G[15:8], G[7:0]	0000 0000
0x94	4	Loudness offset lower 32 bits (O)	O[31:24], O[23:16], O[15:8], O[7:0]	0000 0000
0x95	20	Loudness biquad (b <sub>0</sub> )	u[31:28], b0[27:24], b0[23:16], b0[15:8], b0[7:0]	00FE 5045
		Loudness biquad (b <sub>1</sub> )	u[31:28], b1[27:24], b1[23:16], b1[15:8], b1[7:0]	0F81 AA27
		Loudness biquad (b <sub>2</sub> )	u[31:28], b2[27:24], b2[23:16], b2[15:8], b2[7:0]	0000 D513
		Loudness biquad (a <sub>1</sub> )	u[31:28], a1[27:24], a1[23:16], a1[15:8], a1[7:0]	0000 0000
		Loudness biquad (a <sub>2</sub> )	u[31:28], a2[27:24], a2[23:16], a2[15:8], a2[7:0]	0FFF 2AED

### 11.27 DRC1 Control Register CH1-7 (0x96) – Write

DRC Control selects which channels contribute to the expansion/compression evaluation using DRC1. The evaluation is global such that if one signal forces compression all DRC1 signals will be in compression.

**Table 11-31. Write Register Format**

D31	D30	D29	D28	D27	D26	D25	D24	FUNCTION
x	x	x	x	x	x	x	x	
D23	D22	D21	D20	D19	D18	D17	D16	FUNCTION
x	x	x	x	x	x	x	x	
D15	D14	D13	D12	D11	D10	D9	D8	FUNCTION
x	x	–	–	–	–	–	–	
–	–	<b>0</b>	<b>0</b>	–	–	–	–	<b>Channel 7: Not Included in DRC evaluation</b>
–	–	0	1	–	–	–	–	Channel 7: Pre-volume DRC evaluation
–	–	1	0	–	–	–	–	Channel 7: Post-volume DRC evaluation
–	–	1	1	–	–	–	–	Channel 7: Not Included in DRC evaluation
–	–	–	–	<b>0</b>	<b>0</b>	–	–	<b>Channel 6: Not Included in DRC evaluation</b>
–	–	–	–	0	1	–	–	Channel 6: Pre-volume DRC evaluation
–	–	–	–	1	0	–	–	Channel 6: Post-volume DRC evaluation
–	–	–	–	1	1	–	–	Channel 6: Not Included in DRC evaluation
–	–	–	–	–	–	0	0	Channel 5: Not Included in DRC evaluation
–	–	–	–	–	–	0	1	Channel 5: Pre-volume DRC evaluation
–	–	–	–	–	–	1	0	Channel 5: Post-volume DRC evaluation
–	–	–	–	–	–	1	1	Channel 5: Not Included in DRC evaluation
D7	D6	D5	D4	D3	D2	D1	D0	FUNCTION
<b>0</b>	<b>0</b>	–	–	–	–	–	–	<b>Channel 4: Not Included in DRC evaluation</b>
0	1	–	–	–	–	–	–	Channel 4: Pre-volume DRC evaluation
1	0	–	–	–	–	–	–	Channel 4: Post-volume DRC evaluation
1	1	–	–	–	–	–	–	Channel 4: Not Included in DRC evaluation
–	–	<b>0</b>	<b>0</b>	–	–	–	–	<b>Channel 3: Not Included in DRC evaluation</b>
–	–	0	1	–	–	–	–	Channel 3: Pre-volume DRC evaluation
–	–	1	0	–	–	–	–	Channel 3: Post-volume DRC evaluation
–	–	1	1	–	–	–	–	Channel 3: Not Included in DRC evaluation
–	–	–	–	<b>0</b>	<b>0</b>	–	–	<b>Channel 2 : Not Included in DRC evaluation</b>
–	–	–	–	0	1	–	–	Channel 2: Pre-volume DRC evaluation
–	–	–	–	1	0	–	–	Channel 2: Post-volume DRC evaluation
–	–	–	–	1	1	–	–	Channel 2: Not Included in DRC evaluation
–	–	–	–	–	–	<b>0</b>	<b>0</b>	<b>Channel 1: Not Included in DRC evaluation</b>
–	–	–	–	–	–	0	1	Channel 1: Pre-volume DRC evaluation
–	–	–	–	–	–	1	0	Channel 1: Post-volume DRC evaluation
–	–	–	–	–	–	1	1	Channel 1: Not Included in DRC evaluation

## 11.28 DRC2 Control Register CH8 (0x97) – Write Register

DRC Control selects which channels contribute to the expansion/compression evaluation using DRC2. The evaluation is global such that if one signal forces compression all DRC2 signals will be in compression.

**Table 11-32. Write Register Format**

<b>D31</b>	<b>D30</b>	<b>D29</b>	<b>D28</b>	<b>D27</b>	<b>D26</b>	<b>D25</b>	<b>D24</b>	<b>FUNCTION</b>
x	x	x	x	x	x	x	x	
<b>D23</b>	<b>D22</b>	<b>D21</b>	<b>D20</b>	<b>D19</b>	<b>D18</b>	<b>D17</b>	<b>D16</b>	<b>FUNCTION</b>
x	x	x	x	x	x	x	x	
<b>D15</b>	<b>D14</b>	<b>D13</b>	<b>D12</b>	<b>D11</b>	<b>D10</b>	<b>D9</b>	<b>D8</b>	<b>FUNCTION</b>
x	x	x	x	x	x	x	x	
<b>D7</b>	<b>D6</b>	<b>D5</b>	<b>D4</b>	<b>D3</b>	<b>D2</b>	<b>D1</b>	<b>D0</b>	<b>FUNCTION</b>
x	x	x	x	x	x	0	0	<b>Channel 8: Not included in DRC evaluation</b>
x	x	x	x	x	x	0	1	Channel 8: Pre-volume DRC
x	x	x	x	x	x	1	0	Channel 8: Post-volume DRC
x	x	x	x	x	x	1	1	Channel 8: Not included in DRC evaluation

## 11.29 DRC1 Data Registers (0x98–0x9C)

DRC1 applies to channels 1, 2, 3, 4, 5, 6, and 7.

**Table 11-33. DRC1 Data Register Format**

I <sup>2</sup> C SUB-ADDRESSES	TOTAL BYTES	REGISTER NAME	DESCRIPTION OF CONTENTS	DEFAULT STATE	DATA DECIMAL
0x98	8	Channel 1, 2, 3, 4, 5, 6, and 7 DRC1 energy	u[31:28], E[27:24], E[23:16], E[15:8], E[7:0]	<b>0000 883F</b>	mS
		Channel 1, 2, 3, 4, 5, 6, and 7 DRC1 (1 – energy)	u[31:28], 1–E[27:24], 1–E[23:16], 1–E[15:8], 1–E[7:0]	<b>007F 77C0</b>	
0x99	8	Channel 1, 2, 3, 4, 5, 6, and 7 DRC1 threshold lower 32 bits (T1)	T1[31:24], T1[23:16], T1[15:8], T1[7:0]	<b>0B20 E2B2</b>	dB
		Channel 1, 2, 3, 4, 5, 6, and 7 DRC1 threshold lower 32 bits (T2)	T2[31:24], T2[23:16], T2[15:8], T2[7:0]	<b>06F9 DE58</b>	
0x9A	12	Channel 1, 2, 3, 4, 5, 6, and 7 DRC1 slope (k0)	u[31:28], k0[27:24], k0[23:16], k0[15:8], k0[7:0]	<b>0040 0000</b>	ratio
		Channel 1, 2, 3, 4, 5, 6, and 7 DRC1 slope (k1)	u[31:28], k1[27:24], k1[23:16], k1[15:8], k1[7:0]	<b>0FC0 0000</b>	ratio
		Channel 1, 2, 3, 4, 5, 6, and 7 DRC1 slope (k2)	u[31:28], k2[27:24], k2[23:16], k2[15:8], k2[7:0]	<b>0F90 0000</b>	ratio
0x9B	8	Channel 1, 2, 3, 4, 5, 6, and 7 DRC1 offset-1 lower 32 bits (O1)	O1[31:24], O1[23:16], O1[15:8], O1[7:0]	<b>FF82 3098</b>	dB
		Channel 1, 2, 3, 4, 5, 6, and 7 DRC1 offset-2 lower 32 bits (O2)	O2[31:24], O2[23:16], O2[15:8], O2[7:0]	<b>0195 B2C0</b>	dB
0x9C	16	Channel 1, 2, 3, 4, 5, 6, and 7 DRC1 attack	u[31:28], A[27:24], A[23:16], A[15:8], A[7:0]	<b>0000 883F</b>	mS
		Channel 1, 2, 3, 4, 5, 6, and 7 DRC1 (1 – attack)	u[31:28], 1–A[27:24], 1–A[23:16], 1–A[15:8], 1–A[7:0]	<b>007F 77C0</b>	
		Channel 1, 2, 3, 4, 5, 6, and 7 DRC1 decay	u[31:28], D[27:24], D[23:16], D[15:8], D[7:0]	<b>0000 0056</b>	mS
		Channel 1, 2, 3, 4, 5, 6, and 7 DRC1 (1 – decay)	u[31:28], 1–D[27:24], 1–D[23:16], 1–D[15:8], 1–D[7:0]	<b>003F FFA8</b>	



### 11.30 DRC2 Data Registers (0x9D–0xA1)

DRC2 applies to channel 8.

**Table 11-34. DRC2 Data Register Format**

I <sup>2</sup> C SUBADDRESSES	TOTAL BYTES	REGISTER NAME	DESCRIPTION OF CONTENTS	DEFAULT STATE	DATA DECIMAL
0x9D	8	Channel 8 DRC2 energy	u[31:28], E[27:24], E[23:16], E[15:8], E[7:0]	<b>0000 883F</b>	mS
		Channel 8 DRC2 (1 – energy)	u[31:28], 1–E[27:24], 1–E[23:16], 1–E[15:8], 1–E[7:0]	<b>007F 77C0</b>	
0x9E	8	Channel 8 DRC2 threshold lower 32 bits (T1)	T1[31:24], T1[23:16], T1[15:8], T1[7:0]	<b>0B20 E2B2</b>	dB
		Channel 8 DRC2 threshold lower 32 bits (T2)	T2[31:24], T2[23:16], T2[15:8], T2[7:0]	<b>06F9 DE58</b>	dB
0x9F	12	Channel 8 DRC2 slope (k0)	u[31:28], k0[27:24], k0[23:16], k0[15:8], k0[7:0]	<b>0040 0000</b>	ratio
		Channel 8 DRC2 slope (k1)	u[31:28], k1[27:24], k1[23:16], k1[15:8], k1[7:0]	<b>0FC0 0000</b>	ratio
		Channel 8 DRC2 slope (k2)	u[31:28], k2[27:24], k2[23:16], k2[15:8], k2[7:0]	<b>0F90 0000</b>	ratio
0xA0	8	Channel 8 DRC2 offset 1 lower 32 bits (O1)	O1[31:24], O1[23:16], O1[15:8], O1[7:0]	<b>FF82 3098</b>	dB
		Channel 8 DRC2 offset 2 lower 32 bits (O2)	O2[31:24], O2[23:16], O2[15:8], O2[7:0]	<b>0195 B2C0</b>	dB
0xA1	16	Channel 8 DRC2 attack	u[31:28], A[27:24], A[23:16], A[15:8], A[7:0]	<b>0000 883F</b>	mS
		Channel 8 DRC2 (1 – attack)	u[31:28], 1–A[27:24], 1–A[23:16], 1–A[15:8], 1–A[7:0]	<b>007F 77C0</b>	
		Channel 8 DRC2 decay	u[31:28], D[27:24], D[23:16], D[15:8], D[7:0]	<b>0000 0056</b>	mS
		Channel 8 DRC2 (1 – decay)	u[31:28], 1–D[27:24], 1–D[23:16], 1–D[15:8], 1–D[7:0]	<b>003F FFA8</b>	

### 11.31 DRC Bypass Registers (0xA2–0xA9)

DRC bypass/inline for channels 1, 2, 3, 4, 5, 6, 7, and 8 are mapped into registers 0xA2, 0xA3, 0xA4, 0xA5, 0xA6, 0xA7, 0xA8, and 0xA9, respectively. Eight bytes are written for each channel. Each gain coefficient is in 28-bit (5.23) format, so 0x0080 0000 is a gain of 1. Each gain coefficient is written as a 32-bit word with the upper 4 bits not used.

To enable DRC for a given channel (with unity gain), bypass = 0x0000 0000 and inline = 0x0080 0000.

To disable DRC for a given channel, bypass = 0x0080 0000 and inline = 0x0000 0000.

**Table 11-35. DRC Bypass Register Format**

REGISTER NAME	TOTAL BYTES	CONTENTS	DEFAULT VALUE
Channel bass DRC bypass	8	u[31:28], bypass[27:24], bypass[23:16], bypass[15:8], bypass[7:0]	<b>0x00, 0x80, 0x00, 0x00</b>
Channel DRC inline		u[31:28], inline[27:24], inline[23:16], inline[15:8], inline[7:0]	<b>0x00, 0x00, 0x00, 0x00</b>

### 11.32 Output Select and Mix Registers 8x2 (0x–0xAF)

The pass-through output mixer setting is:

- DAP channel 1 is mapped through the 8x2 crossbar mixer (0xAA) to PWM channel 1
- DAP channel 2 is mapped through the 8x2 crossbar mixer (0xAB) to PWM channel 2
- DAP channel 3 is mapped through the 8x2 crossbar mixer (0xAC) to PWM channel 3
- DAP channel 4 is mapped through the 8x2 crossbar mixer (0xAD) to PWM channel 4
- DAP channel 5 is mapped through the 8x2 crossbar mixer (0xAE) to PWM channel 5

- DAP channel 6 is mapped though the 8x2 crossbar mixer (0xAF) to PWM channel 6

Note that the pass-through output mixer configuration (0xD0 bit 30 = 1) is recommended. Using the remapped output mixer configuration (0xD0 bit 30 = 0) increases the complexity of using some features such as volume and mute.

Total data per register is 8 bytes. The default gain for each selected channel is 1 (00 80 00 00) and 0.5 value is (00 40 00 00) value. The format is 5.23

**Table 11-36. Output Mixer Register Format (Upper 4 Bytes)**

D63	D62	D61	D60	D59	D58	D57	D56	FUNCTION
0	0	0	0					Select channel 1 to output mixer
0	0	0	1					Select channel 2 to output mixer
0	0	1	0					Select channel 3 to output mixer
0	0	1	1					Select channel 4 to output mixer
0	1	0	0					Select channel 5 to output mixer
0	1	0	1					Select channel 6 to output mixer
0	1	1	0					Select channel 7 to output mixer
0	1	1	1					Select channel 8 to output mixer
				G27	G26	G25	G24	Selected channel gain (upper 4 bits)
D55	D54	D53	D52	D51	D50	D49	D48	FUNCTION
G23	G22	G21	G20	G19	G18	G17	G16	Selected channel gain (continued)
D47	D46	D45	D44	D43	D42	D41	D40	FUNCTION
G15	G14	G13	G12	G11	G10	G9	G8	Selected channel gain (continued)
D39	D38	D37	D36	D35	D34	D33	D32	FUNCTION
G7	G6	G5	G4	G3	G2	G1	G0	Selected channel gain (lower 8 bits)

**Table 11-37. Output Mixer Register Format (Lower 4 Bytes)**

D31	D30	D29	D28	D27	D26	D25	D24	FUNCTION
0	0	0	0					Select channel 1 to output mixer
0	0	0	1					Select channel 2 to output mixer
0	0	1	0					Select channel 3 to output mixer
0	0	1	1					Select channel 4 to output mixer
0	1	0	0					Select channel 5 to output mixer
0	1	0	1					Select channel 6 to output mixer
0	1	1	0					Select channel 7 to output mixer
0	1	1	1					Select channel 8 to output mixer
				G27	G26	G25	G24	Selected channel gain (upper 4 bits)
D23	D22	D21	D20	D19	D18	D17	D16	FUNCTION
G23	G22	G21	G20	G19	G18	G17	G16	Selected channel gain (continued)
D15	D14	D13	D12	D11	D10	D9	D8	FUNCTION
G15	G14	G13	G12	G11	G10	G9	G8	Selected channel gain (continued)
D7	D6	D5	D4	D3	D2	D1	D0	FUNCTION
G7	G6	G5	G4	G3	G2	G1	G0	Selected channel gain (lower 8 bits)

### 11.33 8x3 Output Mixer Registers (0xB0–0xB1)

The pass-through output mixer setting is:

- DAP channel 7 is mapped through the 8x3 crossbar mixer (0xB0) to PWM channel 7
- DAP channel 8 is mapped through the 8x3 crossbar mixer (0xB1) to PWM channel 8

The default gain is 1 (00 80 00 00), 0.5 value is (00 40 00 00). Format is 5.23

Total data per register is 12 bytes. The default gain for each selected channel is 1 (0x0080 0000).

**Table 11-38. Output Mixer Register Format (Upper 4 Bytes)**

D96	D95	D94	D93	D92	D91	D90	D89	FUNCTION
0	0	0	0					Select channel 1 to output mixer
0	0	0	1					Select channel 2 to output mixer
0	0	1	0					Select channel 3 to output mixer
0	0	1	1					Select channel 4 to output mixer
0	1	0	0					Select channel 5 to output mixer
0	1	0	1					Select channel 6 to output mixer
0	1	1	0					Select channel 7 to output mixer
0	1	1	1					Select channel 8 to output mixer
				G27	G26	G25	G24	Selected channel gain (upper 4 bits)
D88	D87	D86	D85	D84	D83	D82	D81	FUNCTION
G23	G22	G21	G20	G19	G18	G17	G16	Selected channel gain (continued)
D80	D79	D78	D77	D76	D75	D74	D73	FUNCTION
G15	G14	G13	G12	G11	G10	G9	G8	Selected channel gain (continued)
D72	D71	D70	D69	D68	D67	D66	D65	FUNCTION
G7	G6	G5	G4	G3	G2	G1	G0	Selected channel gain (lower 8 bits)

**Table 11-39. Output Mixer Register Format (Middle 4 Bytes)**

D63	D62	D61	D60	D59	D58	D57	D56	FUNCTION
0	0	0	0					Select channel 1 to output mixer
0	0	0	1					Select channel 2 to output mixer
0	0	1	0					Select channel 3 to output mixer
0	0	1	1					Select channel 4 to output mixer
0	1	0	0					Select channel 5 to output mixer
0	1	0	1					Select channel 6 to output mixer
0	1	1	0					Select channel 7 to output mixer
0	1	1	1					Select channel 8 to output mixer
				G27	G26	G25	G24	Selected channel gain (upper 4 bits)
D55	D54	D53	D52	D51	D50	D49	D48	FUNCTION
G23	G22	G21	G20	G19	G18	G17	G16	Selected channel gain (continued)
D47	D46	D45	D44	D43	D42	D41	D40	FUNCTION
G15	G14	G13	G12	G11	G10	G9	G8	Selected channel gain (continued)
D39	D38	D37	D36	D35	D34	D33	D32	FUNCTION
G7	G6	G5	G4	G3	G2	G1	G0	Selected channel gain (lower 8 bits)

**Table 11-40. Output Mixer Register Format (Lower 4 Bytes)**

D31	D30	D29	D28	D27	D26	D25	D24	FUNCTION
0	0	0	0					Select channel 1 to output mixer
0	0	0	1					Select channel 2 to output mixer
0	0	1	0					Select channel 3 to output mixer
0	0	1	1					Select channel 4 to output mixer
0	1	0	0					Select channel 5 to output mixer
0	1	0	1					Select channel 6 to output mixer
0	1	1	0					Select channel 7 to output mixer
0	1	1	1					Select channel 8 to output mixer
				G27	G26	G25	G24	Selected channel gain (upper 4 bits)
D23	D22	D21	D20	D19	D18	D17	D16	FUNCTION
G23	G22	G21	G20	G19	G18	G17	G16	Selected channel gain (continued)
D15	D14	D13	D12	D11	D10	D9	D8	FUNCTION
G15	G14	G13	G12	G11	G10	G9	G8	Selected channel gain (continued)
D7	D6	D5	D4	D3	D2	D1	D0	FUNCTION
G7	G6	G5	G4	G3	G2	G1	G0	Selected channel gain (lower 8 bits)

### 11.34 ASRC Registers (0xC3-C5)

**Table 11-41. ASRC Status 0xC3 (Read Only)**

D31	D30	D29	D28	D27	D26	D25	D24	FUNCTION
			0					ASRC #1 is down sampling
			1					ASRC #1 is up sampling
							0	ASRC #2 is down sampling
							1	ASRC #2 is up sampling
D23	D22	D21	D20	D19	D18	D17	D16	FUNCTION
	0							ASRC #1 clocks are valid
	1							Error in ASRC #1 clocks
			0					ASRC #2 clocks are valid
			1					Error in ASRC #2 clocks
					0			ASRC #1 is unlocked
					1			ASRC #1 is locked
							0	ASRC #2 is unlocked
							1	ASRC #2 is locked
D15	D14	D13	D12	D11	D10	D9	D8	FUNCTION
			0					ASRC #1 is unmuted
			1					ASRC #1 is muted
							0	ASRC #2 is unmuted
							1	ASRC #2 is muted
D7	D6	D5	D4	D3	D2	D1	D0	FUNCTION
			0					RESERVED
			1					RESERVED
							0	RESERVED
							1	RESERVED

**Table 11-42. ASRC Control (0xC4)**

D31	D30	D29	D28	D27	D26	D25	D24	FUNCTION
			0					ASRCs in independent mode (clock error on one will not affect the other)
			1					ASRCs in coupled mode (clock error on one will trigger muting of both ASRCs)
							0	ASRC2 uses LRCK and SCK
							1	ASRC2 uses LRCK2 and SCK2
D23	D22	D21	D20	D19	D18	D17	D16	FUNCTION
	0							Normal (32-sample) FIFO latency for ASRC1
	1							Low (16-sample) FIFO latency for ASRC1
			0					Normal (32-sample) FIFO latency for ASRC2
			1					Low (16-sample) FIFO latency for ASRC2
					0			Do not dither ASRC output
					1			Dither ASRC output before truncation back to 24-bit
							0	ASRC unlock will not cause ASRC clock error
							1	ASRC unlock will cause ASRC clock error
D15	D14	D13	D12	D11	D10	D9	D8	FUNCTION
	0							ASRC1 is enabled
	1							ASRC1 is bypassed

**Table 11-42. ASRC Control (0xC4) (continued)**

D31	D30	D29	D28	D27	D26	D25	D24	FUNCTION
			0					ASRC2 is enabled
			1					ASRC2 is bypassed
					0			RESERVED
					1			RESERVED
							0	RESERVED
							1	RESERVED
D7	D6	D5	D4	D3	D2	D1	D0	FUNCTION
0	0	0	0					ASRC #1 Right Justified 16bit
0	0	0	1					ASRC #1 Right Justified 20bit
0	0	1	0					ASRC #1 Right Justified 24bit
0	0	1	1					ASRC #1 I2S 16bit
0	1	0	0					ASRC #1 I2S 20bit
<b>0</b>	<b>1</b>	<b>0</b>	<b>1</b>					<b>ASRC #1 I2S 24bit</b>
0	1	1	0					ASRC #1 Left Justified 16bit
0	1	1	1					ASRC #1 Left Justified 20bit
1	0	0	0					ASRC #1 Left Justified 24bit
				0	0	0	0	ASRC #2 Right Justified 16bit
				0	0	0	1	ASRC #2 Right Justified 20bit
				0	0	1	0	ASRC #2 Right Justified 24bit
				0	0	1	1	ASRC #2 I2S 16bit
				0	1	0	0	ASRC #2 I2S 20bit
				<b>0</b>	<b>1</b>	<b>0</b>	<b>1</b>	<b>ASRC #2 I2S 24bit</b>
				0	1	1	0	ASRC #2 Left Justified 16bit
				0	1	1	1	ASRC #2 Left Justified 20bit
				1	0	0	0	ASRC #2 Left Justified 24bit

Bit D28: Having ASRC's act independently allows two sources, such as S/PDIF receiver and a bluetooth module to be mixed comfortably, without issue if one of the sources fails/stops. Usage example: mixing audio from games console with bluetooth audio input. If bluetooth connection is dropped, the audio from console will not mute.

Bit D18: Select truncation of the data on the output of the SRC, with or without applied Dither. This is based on user preference. TI suggests dithering before truncation.

**Table 11-43. ASRC Mode Control 0xC5**

D31	D30	D29	D28	D27	D26	D25	D24	FUNCTION
					0			Disable MCLKO (PSVC output is available, Default)
					1			Enable MCLKO (PSVC output is not available)
						0		Disable SCLKO (SCLK2 input is available, Default)
						1		Enable SCLKO (SCLK2 input is not available)
							0	Disable LRCLKO (LRCLK2 input is available, Default)
							1	Enable LRCLKO (LRCLK2 input is not available)
D23	D22	D21	D20	D19	D18	D17	D16	FUNCTION
			0					Serial clock output sampling rate is 44.1/48 kHz
			1					Serial clock output sampling rate is the internal sampling rate
							0	Disable SDIN5 (SDOUT is available)

**Table 11-43. ASRC Mode Control 0xC5 (continued)**

D31	D30	D29	D28	D27	D26	D25	D24	FUNCTION
							1	Enable SDIN5 (SDOUT is not available)
D15	D14	D13	D12	D11	D10	D9	D8	FUNCTION
						0	0	Serial output muted
						0	1	Select ASRC channel 1+2 (from SDIN1) outputs for serial out
						1	0	Select ASRC channel 3+4 (from SDIN2) outputs for serial out
						1	1	Select DAP output for serial out
D7	D6	D5	D4	D3	D2	D1	D0	FUNCTION
		0	0					MDIV0/1 -Division factor for MCLKO Division factor for MCLKO <b>00 :Divide by 1 (Default)</b> 01 : Divide by 2 10 : Divide by 4 11 : Divide by 8
		0	1					
		1	0					
		1	1					
						0	0	Sampling Rate <b>00 : 88.2/96 kHz (Default)</b> 01 : 176.4/192 kHz 1x : 44.1/48 kHz
						0	1	
						1	0	
						1	1	

For 192kHz Native 4ch process flow, ALWAYS set D20 to 1, to ensure correct data output.

### 11.35 Auto Mute Behavior (0xCC)

**Table 11-44. Auto Mute Behavior**

D31	D30	D29	D28	D27	D26	D25	D24	FUNCTION
								Reserved
D23	D22	D21	D20	D19	D18	D17	D16	FUNCTION
								Reserved
D15	D14	D13	D12	D11	D10	D9	D8	FUNCTION
							0	Disable noise shaper on auto mute
							1	Do not disable noise shaper on auto mute
D7	D6	D5	D4	D3	D2	D1	D0	FUNCTION
							0	Do not stop PWM on auto mute (Stay at duty 50:50)
							1	Stop PWM on auto mute

### 11.36 PSVC Volume Biquad Register (0xCF)

Each gain coefficient is in 28-bit (5.23) format, so 0x80 0000 is a gain of 1. Each gain coefficient is written as a 32-bit word with the upper four bits not used. Note that this register should be used only with the PSVC feature its use is not required. For systems not using this feature, it is recommended that this biquad be set to all-pass (default).

**Table 11-45. Volume Biquad Register Format (Default = All-Pass)**

DESCRIPTION	REGISTER FIELD CONTENTS	DEFAULT GAIN COEFFICIENT VALUES	
		DECIMAL	HEX
b <sub>0</sub> coefficient	u[31:28], b0[27:24], b0[23:16], b0[15:8], b0[7:0]	1.0	0080 0000
b <sub>1</sub> coefficient	u[31:28], b1[27:24], b1[23:16], b1[15:8], b1[7:0]	0.0	0000 0000
b <sub>2</sub> coefficient	u[31:28], b2[27:24], b2[23:16], b2[15:8], b2[7:0]	0.0	0000 0000
a <sub>1</sub> coefficient	u[31:28], a1[27:24], a1[23:16], a1[15:8], a1[7:0]	0.0	0000 0000
a <sub>2</sub> coefficient	u[31:28], a2[27:24], a2[23:16], a2[15:8], a2[7:0]	0.0	0000 0000

### 11.37 Volume, Treble, and Bass Slew Rates Register (0xD0)

**Table 11-46. Volume Gain Update Rate (Slew Rate)**

D31	D30	D29–D11	D10	D9	D8	FUNCTION
-	-	-	0	0	0	512 step update at 4 Fs, 21.3 ms at 96 kHz
-	-	-	0	0	1	<b>1024 step update at 4 Fs, 42.65 ms at 96 kHz</b>
-	-	-	0	1	0	2048 step update at 4 Fs, 85 ms at 96 kHz
-	-	-	0	1	1	2048 step update at 4 Fs, 85 ms at 96 kHz
-	-	-	1	0	0	256 step update at 4 Fs, 10.65 ms at 96kHz
1	0	0	-	-	-	Abort volume ramp if there is a change in the volume of any channel
0	1	0	-	-	-	Enable PWM shutdown on headphone change

**Table 11-47. Treble and Bass Gain Step Size (Slew Rate)**

D7	D6	D5	D4	D3	D2	D1	D0	FUNCTION
0	0	0	0	0	0	0	0	No operation
0	0	0	0	0	1	0	0	Minimum rate – Updates every 0.083 ms (every LRCLK at 48 kHz)
0	0	1	0	0	0	0	0	Updates every 0.67 ms (32 LRCLKs at 48 kHz)



**Table 11-47. Treble and Bass Gain Step Size (Slew Rate) (continued)**

D7	D6	D5	D4	D3	D2	D1	D0	FUNCTION
0	0	1	1	1	1	1	1	Default rate - Updates every 1.31 ms (63 LRCLKs at 48 kHz). This is the maximum constant time that can be set for all sample rates.
1	1	1	1	1	1	1	1	Maximum rate – Updates every 5.08 ms (every 255 LRCLKs at 48 kHz)

**Note:** Once the volume command is given, no I2C commands should be issued until volume ramp has finished. The lock out time is 1.5 x slew rate or defined in 0xD0

### 11.38 Volume Registers (0xD1–0xD9)

Channels 1, 2, 3, 4, 5, 6, 7, and 8 are mapped into registers 0xD1, 0xD2, 0xD3, 0xD4, 0xD5, 0xD6, 0xD7, and 0xD8, respectively. The default volume for all channels is 0 dB.

Master volume is mapped into register 0xD9. The default for the master volume is mute.

Bits D31–D12 are reserved. D9–D0 are the volume index, their values can be calculated from [Table 11-49](#).

**Table 11-48. Volume Register Format**

<b>D31</b>	<b>D30</b>	<b>D29</b>	<b>D28</b>	<b>D27</b>	<b>D26</b>	<b>D25</b>	<b>D24</b>	<b>FUNCTION</b>
RESERVED	RESERVED	RESERVED	RESERVED	RESERVED	RESERVED	RESERVED	RESERVED	RESERVED
<b>D23</b>	<b>D22</b>	<b>D21</b>	<b>D20</b>	<b>D19</b>	<b>D18</b>	<b>D17</b>	<b>D16</b>	<b>FUNCTION</b>
RESERVED	RESERVED	RESERVED	RESERVED	RESERVED	RESERVED	RESERVED	RESERVED	RESERVED
<b>D15</b>	<b>D14</b>	<b>D13</b>	<b>D12</b>	<b>D11</b>	<b>D10</b>	<b>D9</b>	<b>D8</b>	<b>FUNCTION</b>
RESERVED	RESERVED	RESERVED	RESERVED	RESERVED	RESERVED	V9	V8	Volume
<b>D7</b>	<b>D6</b>	<b>D5</b>	<b>D4</b>	<b>D3</b>	<b>D2</b>	<b>D1</b>	<b>D0</b>	<b>FUNCTION</b>
V7	V6	V5	V4	V3	V2	V1	V0	Volume

**Table 11-49. Master and Individual Volume Controls**

<b>VOLUME INDEX (H)</b>	<b>GAIN/INDEX(dB)</b>
001	17.75
002	17.5
003	17.25
004	17
005	16.75
006	16.5
007	16.25
008	16
009	15.75
00A	15.5
00B	15.25
00C	15
00D	14.75
00E	14.5
00F	14.25
010	14
...	...
044	1
045	0.75
046	0.5
047	0.25
048	0
049	-0.25
04A	-0.5
04B	-0.75
04C	-1
...	...
240	-126
241	-126.25
242	-126.5
243	-126.75
244	-127
245	<b>Mute</b>
<b>TO</b>	
<b>3FF</b>	<b>RESERVED</b>

### 11.39 Bass Filter Set Register (0xDA)

To use the bass and treble function, the bass and treble bypass registers (0x89–0x90) must be configured as inline (default is bypass).

See [Table 11-29](#) to configure the Bass Filter mode as inline or bypass.

**Table 11-50. Channel 8 (Subwoofer)**

D31	D30	D29	D28	D27	D26	D25	D24	FUNCTION
0	0	0	0	0	0	0	0	No change
0	0	0	0	0	0	0	1	Bass filter set 1
0	0	0	0	0	0	1	0	Bass filter set 2
0	<b>0</b>	<b>0</b>	<b>0</b>	<b>0</b>	<b>0</b>	<b>1</b>	<b>1</b>	<b>Bass filter set 3</b>
0	0	0	0	0	1	0	0	Bass filter set 4
0	0	0	0	0	1	0	1	Bass filter set 5
0	0	0	0	0	1	1	0	Reserved
0	0	0	0	0	1	1	1	Reserved

**Table 11-51. Channels 6 and 5 (Right and Left Lineout in 6-Channel Configuration; Right and Left Surround in 8-Channel Configuration)**

D23	D22	D21	D20	D19	D18	D17	D16	FUNCTION
0	0	0	0	0	0	0	0	No change
0	0	0	0	0	0	0	1	Bass filter set 1
0	0	0	0	0	0	1	0	Bass filter set 2
<b>0</b>	<b>0</b>	<b>0</b>	<b>0</b>	<b>0</b>	<b>0</b>	<b>1</b>	<b>1</b>	<b>Bass filter set 3</b>
0	0	0	0	0	1	0	0	Bass filter set 4
0	0	0	0	0	1	0	1	Bass filter set 5
0	0	0	0	0	1	1	0	Reserved
0	0	0	0	0	1	1	1	Reserved

**Table 11-52. Channels 4 and 3 (Right and Left Rear)**

D15	D14	D13	D12	D11	D10	D9	D8	FUNCTION
0	0	0	0	0	0	0	0	No change
0	0	0	0	0	0	0	1	Bass filter set 1
0	0	0	0	0	0	1	0	Bass filter set 2
<b>0</b>	<b>0</b>	<b>0</b>	<b>0</b>	<b>0</b>	<b>0</b>	<b>1</b>	<b>1</b>	<b>Bass filter set 3</b>
0	0	0	0	0	1	0	0	Bass filter set 4
0	0	0	0	0	1	0	1	Bass filter set 5
0	0	0	0	0	1	1	0	Illegal
0	0	0	0	0	1	1	1	Illegal

**Table 11-53. Channels 7, 2, and 1 (Center, Right Front, and Left Front)**

D7	D6	D5	D4	D3	D2	D1	D0	FUNCTION
0	0	0	0	0	0	0	0	No change
0	0	0	0	0	0	0	1	Bass filter set 1
0	0	0	0	0	0	1	0	Bass filter set 2
<b>0</b>	<b>0</b>	<b>0</b>	<b>0</b>	<b>0</b>	<b>0</b>	<b>1</b>	<b>1</b>	<b>Bass filter set 3</b>
0	0	0	0	0	1	0	0	Bass filter set 4
0	0	0	0	0	1	0	1	Bass filter set 5
0	0	0	0	0	1	1	0	Illegal
0	0	0	0	0	1	1	1	Illegal

#### 11.40 Bass Filter Index Register (0xDB)

Index values above 0x24 are invalid. To use the bass and treble function, the bass and treble bypass registers (0x89–0x90) must be configured as inline (default is bypass).

**Table 11-54. Bass Filter Index Register Format**

I <sup>2</sup> C SUBADDRESS	TOTAL BYTES	REGISTER NAME	DESCRIPTION OF CONTENTS	DEFAULT STATE
0xDB	4	Bass filter index (BFI)	Ch8_BFI[31:24], Ch65_BFI[23:16], Ch43_BFI[15:8], Ch721_BFI[7:0]	<b>1212 1212</b>

**Table 11-55. Bass Filter Indexes**

BASS INDEX VALUE	ADJUSTMENT (dB)	BASS INDEX VALUE	ADJUSTMENT (dB)
0x00	18	0x13	–1
0x01	17	0x14	–2
0x02	16	0x15	–3
0x03	15	0x16	–4
0x04	14	0x17	–5
0x05	13	0x18	–6
0x06	12	0x19	–7
0x07	11	0x1A	–8
0x08	10	0x1B	–9
0x09	9	0x1C	–10
0x0A	8	0x1D	–11
0x0B	7	0x1E	–12
0x0C	6	0x1F	–13
0x0D	5	0x20	–14
0x0E	4	0x21	–15
0x0F	3	0x22	–16
0x10	2	0x23	–17
0x11	1	0x24	–18
<b>0x12</b>	<b>0</b>		

### 11.41 Treble Filter Set Register (0xDC)

Bits D31–D27 are reserved. To use the bass and treble function, the bass and treble bypass registers (0x89 - 0x90) must be configured as inline (enabled).

See [Table 11-29](#) to configure the Treble Filter mode as inline or bypass.

**Table 11-56. Channel 8 (Subwoofer)**

D31	D30	D29	D28	D27	D26	D25	D24	FUNCTION
0	0	0	0	0	0	0	0	No change
0	0	0	0	0	0	0	1	Treble filter set 1
0	0	0	0	0	0	1	0	Treble filter set 2
<b>0</b>	<b>0</b>	<b>0</b>	<b>0</b>	<b>0</b>	<b>0</b>	<b>1</b>	<b>1</b>	<b>Treble filter set 3</b>
0	0	0	0	0	1	0	0	Treble filter set 4
0	0	0	0	0	1	0	1	Treble filter set 5
0	0	0	0	0	1	1	0	Illegal
0	0	0	0	0	1	1	1	Illegal

Bits D23–D19 are reserved.

**Table 11-57. Channels 6 and 5 (Right and Left Lineout in 6-Channel Configuration; Right and Left Surround in 8-Channel Configuration)**

D23	D22	D21	D20	D19	D18	D17	D16	FUNCTION
0	0	0	0	0	0	0	0	No change
0	0	0	0	0	0	0	1	Treble filter set 1
0	0	0	0	0	0	1	0	Treble filter set 2
<b>0</b>	<b>0</b>	<b>0</b>	<b>0</b>	<b>0</b>	<b>0</b>	<b>1</b>	<b>1</b>	<b>Treble filter set 3</b>
0	0	0	0	0	1	0	0	Treble filter set 4
0	0	0	0	0	1	0	1	Treble filter set 5
0	0	0	0	0	1	1	0	Illegal
0	0	0	0	0	1	1	1	Illegal

Bits D15–D11 are reserved.

**Table 11-58. Channels 4 and 3 (Right and Left Rear)**

D15	D14	D13	D12	D11	D10	D9	D8	FUNCTION
0	0	0	0	0	0	0	0	No change
0	0	0	0	0	0	0	1	Treble filter set 1
0	0	0	0	0	0	1	0	Treble filter set 2
<b>0</b>	<b>0</b>	<b>0</b>	<b>0</b>	<b>0</b>	<b>0</b>	<b>1</b>	<b>1</b>	<b>Treble filter set 3</b>
0	0	0	0	0	1	0	0	Treble filter set 4
0	0	0	0	0	1	0	1	Treble filter set 5
0	0	0	0	0	1	1	0	Illegal
0	0	0	0	0	1	1	1	Illegal

Bits D7–D3 are reserved.

**Table 11-59. Channels 7, 2, and 1 (Center, Right Front, and Left Front)**

D7	D6	D5	D4	D3	D2	D1	D0	FUNCTION
0	0	0	0	0	0	0	0	No change
0	0	0	0	0	0	0	1	Treble filter set 1
0	0	0	0	0	0	1	0	Treble filter set 2
<b>0</b>	<b>0</b>	<b>0</b>	<b>0</b>	<b>0</b>	<b>0</b>	<b>1</b>	<b>1</b>	<b>Treble filter set 3</b>
0	0	0	0	0	1	0	0	Treble filter set 4
0	0	0	0	0	1	0	1	Treble filter set 5
0	0	0	0	0	1	1	0	Illegal
0	0	0	0	0	1	1	1	Illegal

### 11.42 Treble Filter Index (0xDD)

Index values above 0x24 are invalid. To use the bass and treble function, the bass and treble bypass registers (0x89 - 0x90) must be configured as inline (enabled).

**Table 11-60. Treble Filter Index Register Format**

I <sup>2</sup> C SUBADDRESS	TOTAL BYTES	REGISTER NAME	DESCRIPTION OF CONTENTS	DEFAULT STATE
0xDD	4	Treble filter index (TFI)	Ch8_TFI[31:24], Ch65_TFI[23:16], Ch43_TFI[15:8], Ch721_TFI[7:0]	<b>1212 1212</b>

**Table 11-61. Treble Filter Indexes**

TREBLE INDEX VALUE	ADJUSTMENT (dB)	TREBLE INDEX VALUE	ADJUSTMENT (dB)
0x00	18	0x13	-1
0x01	17	0x14	-2
0x02	16	0x15	-3
0x03	15	0x16	-4
0x04	14	0x17	-5
0x05	13	0x18	-6
0x06	12	0x19	-7
0x07	11	0x1A	-8
0x08	10	0x1B	-9
0x09	9	0x1C	-10
0x0A	8	0x1D	-11
0x0B	7	0x1E	-12
0x0C	6	0x1F	-13
0x0D	5	0x20	-14
0x0E	4	0x21	-15
0x0F	3	0x22	-16
0x10	2	0x23	-17
0x11	1	0x24	-18
<b>0x12</b>	<b>0</b>		

### 11.43 AM Mode Register (0xDE)

Bits D31–D25 and D23–D21 are reserved.

BCD = Binary Coded Decimal.

**Table 11-62. AM Mode Register Format**

D31	D30	D29	D28	D27	D26	D25	D24	FUNCTION
							0	AM Avoidance Mode: Use Frequency Scaling
							1	AM Avoidance Mode: Use Sampling Rate Conversion Mode
D23	D22	D21	D20	D19	D18	D17	D16	FUNCTION
			0	–	–	–	–	AM mode disabled
			1	–	–	–	–	AM mode enabled
			–	0	0	–	–	Select sequence 1
			–	0	1	–	–	Select sequence 2
			–	1	0	–	–	Select sequence 3
			–	1	1	–	–	Select sequence 4
			–	–	–	0	–	IF frequency = 455 kHz
			–	–	–	1	–	IF frequency = 262.5 kHz
			–	–	–	–	0	Use BCD-tuned frequency
			–	–	–	–	1	Use binary-tuned frequency

**Table 11-63. AM Tuned Frequency Register in BCD Mode (Lower 2 Bytes of 0xDE)**

D15	D14	D13	D12	D11	D10	D9	D8	FUNCTION
0	0	0	B0	–	–	–	–	BCD frequency (1000s kHz)
–	–	–	–	B3	B2	B1	B0	BCD frequency (100s kHz)
0	0	0	0	0	0	0	0	Default value
D7	D6	D5	D4	D3	D2	D1	D0	FUNCTION
B3	B2	B1	B0	–	–	–	–	BCD frequency (10s kHz)
–	–	–	–	B3	B2	B1	B0	BCD frequency (1s kHz)
0	0	0	0	0	0	0	0	Default value

**Table 11-64. AM Tuned Frequency Register in Binary Mode (Lower 2 Bytes of 0xDE)**

D15	D14	D13	D12	D11	D10	D9	D8	FUNCTION
0	0	0	0	0	B10	B9	B8	Binary frequency (upper 3 bits)
0	0	0	0	0	0	0	0	Default value
D7	D6	D5	D4	D3	D2	D1	D0	FUNCTION
B7	B6	B5	B4	B3	B2	B1	B0	Binary frequency (lower 8 bits)
0	0	0	0	0	0	0	0	Default value



### 11.44 PSVC Range Register (0xDF)

Bits D31–D2 are zero.

**Table 11-65. PSVC Range Register Format**

D31–D2	D1	D0	FUNCTION
0	0	0	12.04-dB control range for PSVC
0	0	1	18.06-dB control range for PSVC
<b>0</b>	<b>1</b>	<b>0</b>	<b>24.08-dB control range for PSVC</b>
0	1	1	Ignore – retain last value

### 11.45 General Control Register (0xE0)

Bits D31–D4 are zero. Bit D0 is reserved.

**Table 11-66. General Control Register Format**

D31–D4	D3	D2	D1	D0	FUNCTION
	–	–	<b>0</b>	–	<b>Normal</b>
	–	–	1	–	Lineout/6 Channel mode (6Channels will be pwm processed)
<b>0</b>		<b>0</b>	–	–	<b>Power Supply Volume Control Disable</b>
0		1	–	–	Power Supply Volume Control Enable
<b>0</b>	<b>0</b>	–	–	–	<b>Subwoofer Part of PSVC</b>
0	1	–	–	–	Subwoofer Separate from PSVC

### 11.46 96kHz Dolby Downmix Coefficients (0xE3 to 0xE8)

Each gain coefficient is in 28-bit (5.23) format, so 0x80 0000 is a gain of 1. Each gain coefficient is written as a 32-bit word with the upper four bits not used. For eight gain coefficients, the total is 32 bytes.

**Table 11-67. 96kHz Dolby Downmix Coefficients**

I <sup>2</sup> C SUBADDRESS	TOTAL BYTES	REGISTER Fields	DESCRIPTION OF CONTENTS	DEFAULT STATE
0xE3	4	dolby_COEF1L_96k	96kHz SDIN1-left to SDOUT-left down-mix coefficient (default = 1/3.121) . This is also the coefficient for SDIN1-right to SDOUT-right.	00 29 03 33
0xE4	4	dolby_COEF1R_96k	96kHz SDIN4-left to SDOUT-left down-mix coefficient. This is also the coefficient for SDIN4-left to SDOUT-right.	00 1C FE EF
0xE5	4	TBD	96kHz SDIN2-left to SDOUT-right down-mix coefficient.	FF E3 01 11
0xE6	4	TBD	96kHz SDIN2-right to SDOUT-right down-mix coefficient.	FF E3 01 11
0xE7	4	TBD	96kHz SDIN2-left to SDOUT-left down-mix coefficient.	FF E3 01 11
0xE8	4	TBD	96kHz SDIN2-right to SDOUT-left down-mix coefficient.	FF E3 01 11

### 11.47 THD Manager Configuration (0xE9 and 0xEA)

0xE9 (4B) THD Manager (pre) - provide boost if desired to clip

0xEA (4B) THD Manager (post) - cut clipping signal to final level

Both registers have a 5.23 register format (28bit coefficient)

Valid register values 0000 0000 to 0FFF FFFF

Writes to upper byte is ignored

0dB default value 0080 0000

max positive value 07 FF FFFF = +24dB

negative values 08xx xxxx will invert the signal amplitude

**Table 11-68. THD Manager Configuration**

I <sup>2</sup> C SUBADDRESS	TOTAL BYTES	REGISTER Fields	DESCRIPTION OF CONTENTS	DEFAULT STATE
0xE9	4	prescale	THD Manager (pre) - provide boost if desired to clip	0080 0000
0xEA	4	postscale	THD Manager (post) - cut clipping signal to final level	0080 0000

### 11.48 SDIN5 Input Mixer (0xEC–0xF3)

Each gain coefficient is in 28-bit (5.23) format, so 0x80 0000 is a gain of 1. Each gain coefficient is written as a 32-bit word with the upper four bits not used. For eight gain coefficients, the total is 32 bytes.

**Table 11-69. SDIN5 Input Mixers**

I <sup>2</sup> C SUBADDRESS	TOTAL BYTES	REGISTER Fields	DESCRIPTION OF CONTENTS	DEFAULT STATE
0xEC	8	I_to_ipmix[1]	SDIN5-left (Ch9) I to input mixer 1 coefficient (default = 0) u[31:28],L[27:0]	0000 0000
		J_to_ipmix[1]	SDIN5-right (Ch10) J to input mixer 1 coefficient (default = 0) u[31:28],R[27:0]	0000 0000
0xED	8	I_to_ipmix[2]	SDIN5-left (Ch9) I to input mixer 2 coefficient (default = 0) u[31:28],L[27:0]	0000 0000
		J_to_ipmix[2]	SDIN5-right (Ch10) J to input mixer 2 coefficient (default = 0) u[31:28],R[27:0]	0000 0000
0xEE	8	I_to_ipmix[3]	SDIN5-left (Ch9) I to input mixer 3 coefficient (default = 0) u[31:28],L[27:0]	0000 0000
		J_to_ipmix[3]	SDIN5-right (Ch10) J to input mixer 3 coefficient (default = 0) u[31:28],R[27:0]	0000 0000
0xEF	8	I_to_ipmix[4]	SDIN5-left (Ch9) I to input mixer 4 coefficient (default = 0) u[31:28],L[27:0]	0000 0000
		J_to_ipmix[4]	SDIN5-right (Ch10) J to input mixer 4 coefficient (default = 0) u[31:28],R[27:0]	0000 0000
0xF0	8	I_to_ipmix[5]	SDIN5-left (Ch9) I to input mixer 5 coefficient (default = 0) u[31:28],L[27:0]	0000 0000
		J_to_ipmix[5]	SDIN5-right (Ch10) J to input mixer 5 coefficient (default = 0) u[31:28],R[27:0]	0000 0000
0xF1	8	I_to_ipmix[6]	SDIN5-left (Ch9) I to input mixer 6 coefficient (default = 0) u[31:28],L[27:0]	0000 0000
		J_to_ipmix[6]	SDIN5-right (Ch10) J to input mixer 6 coefficient (default = 0) u[31:28],R[27:0]	0000 0000
0xF2	8	I_to_ipmix[7]	SDIN5-left (Ch9) I to input mixer 7 coefficient (default = 0) u[31:28],L[27:0]	0000 0000
		J_to_ipmix[7]	SDIN5-right (Ch10) J to input mixer 7 coefficient (default = 0) u[31:28],R[27:0]	0000 0000
0xF3	8	I_to_ipmix[8]	SDIN5-left (Ch9) I to input mixer 8 coefficient (default = 0) u[31:28],L[27:0]	0000 0000
		J_to_ipmix[8]	SDIN5-right (Ch10) J to input mixer 8 coefficient (default = 0) u[31:28],R[27:0]	0000 0000

### 11.49 192kHz Process Flow Output Mixer (0xF4–0xF7)

Each gain coefficient is in 28-bit (5.23) format, so 0x80 0000 is a gain of 1. Each gain coefficient is written as a 32-bit word with the upper four bits not used. For eight gain coefficients, the total is 32 bytes.

**Table 11-70. 192kHz Process Flow Output Mixer**

I <sup>2</sup> C SUBADDRESS	TOTAL BYTES	REGISTER Fields	DESCRIPTION OF CONTENTS	DEFAULT STATE
0xF4	16	P1_to_opmix[1]	Path 1 processing to output mixer 1 coefficient (default = 1) u[31:28], P1[27:0]	0080 0000
		P2_to_opmix[1]	Path 2 processing to output mixer 1 coefficient (default = 0) u[31:28], P2[27:0]	0000 0000
		P3_to_opmix[1]	Path 3 processing to output mixer 1 coefficient (default = 0) u[31:28], P3[27:0]	0000 0000
		P4_to_opmix[1]	Path 4 processing to output mixer 1 coefficient (default = 0) u[31:28], P4[27:0]	0000 0000
0xF5	16	P1_to_opmix[2]	Path 1 processing to output mixer 2 coefficient (default = 0) u[31:28], P1[27:0]	0000 0000
		P2_to_opmix[2]	Path 2 processing to output mixer 2 coefficient (default = 1) u[31:28], P2[27:0]	0080 0000
		P3_to_opmix[2]	Path 3 processing to output mixer 2 coefficient (default = 0) u[31:28], P3[27:0]	0000 0000
		P4_to_opmix[2]	Path 4 processing to output mixer 2 coefficient (default = 0) u[31:28], P4[27:0]	0000 0000
0xF6	16	P1_to_opmix[3]	Path 1 processing to output mixer 3 coefficient (default = 0) u[31:28], P1[27:0]	0000 0000
		P2_to_opmix[3]	Path 2 processing to output mixer 3 coefficient (default = 0) u[31:28], P2[27:0]	0000 0000
		P3_to_opmix[3]	Path 3 processing to output mixer 3 coefficient (default = 1) u[31:28], P3[27:0]	0080 0000
		P4_to_opmix[3]	Path 4 processing to output mixer 3 coefficient (default = 0) u[31:28], P4[27:0]	0000 0000
0xF7	16	P1_to_opmix[4]	Path 1 processing to output mixer 4 coefficient (default = 0) u[31:28], P1[27:0]	0000 0000
		P2_to_opmix[4]	Path 2 processing to output mixer 4 coefficient (default = 0) u[31:28], P2[27:0]	0000 0000
		P3_to_opmix[4]	Path 3 processing to output mixer 4 coefficient (default = 0) u[31:28], P3[27:0]	0000 0000
		P4_to_opmix[4]	Path 4 processing to output mixer 4 coefficient (default = 1) u[31:28], P4[27:0]	0080 0000

### 11.50 192kHz Dolby Downmix Coefficients (0xFB and 0xFC)

Each gain coefficient is in 28-bit (5.23) format, so 0x80 0000 is a gain of 1. Each gain coefficient is written as a 32-bit word with the upper four bits not used. For eight gain coefficients, the total is 32 bytes.

**Table 11-71. 192kHz Dolby Downmix Coefficients**

I <sup>2</sup> C SUBADDRESS	TOTAL BYTES	REGISTER Fields	DESCRIPTION OF CONTENTS	DEFAULT STATE
0xFB	16	dolby_COEF1L (D1_L)	192kHz SDIN1-left to SDOUT-left down-mix coefficient (default = 1/3.121)	0029 0333
		dolby_COEF2L (D2_L)	192kHz SDIN1-right to SDOUT-left down-mix coefficient (default = 0.707/3.121)	001C FEEF
		dolby_COEF3L (D3_L)	192kHz SDIN3-left to SDOUT-left down-mix coefficient (default = -0.707/3.121)	FFE3 0111
		dolby_COEF4L (D4_L)	192kHz SDIN3-right to SDOUT-left down-mix coefficient (default = -0.707/3.121)	FFE3 0111
0xFC	16	dolby_COEF1R (D1_R)	192kHz SDIN1-left to SDOUT-right down-mix coefficient (default = 1/3.121)	0029 0333
		dolby_COEF2R (D2_R)	192kHz SDIN1-right to SDOUT-right down-mix coefficient (default = 0.707/3.121)	001C FEEF
		dolby_COEF3R (D3_R)	192kHz SDIN3-left to SDOUT-right down-mix coefficient (default = 0.707/3.121)	001C FEEF
		dolby_COEF4R (D4_R)	192kHz SDIN3-right to SDOUT-right down-mix coefficient (default = 0.707/3.121)	001C FEEF

### Revision History

NOTE: Page numbers for previous revisions may differ from page numbers in the current version.

Changes from Original (April 2013) to Revision A	Page
<ul style="list-style-type: none"> <li>Changed the TAS5558 device From: Preview To: Active .....</li> </ul>	<u>2</u>

**PACKAGING INFORMATION**

Orderable Device	Status (1)	Package Type	Package Drawing	Pins	Package Qty	Eco Plan (2)	Lead/Ball Finish	MSL Peak Temp (3)	Op Temp (°C)	Device Marking (4/5)	Samples
TAS5558DCA	ACTIVE	HTSSOP	DCA	56	35	Green (RoHS & no Sb/Br)	CU NIPDAU	Level-3-260C-168 HR	-40 to 85	TAS5558	<a href="#">Samples</a>
TAS5558DCAR	ACTIVE	HTSSOP	DCA	56	2000	Green (RoHS & no Sb/Br)	CU NIPDAU	Level-3-260C-168 HR	-40 to 85	TAS5558	<a href="#">Samples</a>

(1) The marketing status values are defined as follows:

**ACTIVE:** Product device recommended for new designs.

**LIFEBUY:** TI has announced that the device will be discontinued, and a lifetime-buy period is in effect.

**NRND:** Not recommended for new designs. Device is in production to support existing customers, but TI does not recommend using this part in a new design.

**PREVIEW:** Device has been announced but is not in production. Samples may or may not be available.

**OBSOLETE:** TI has discontinued the production of the device.

(2) Eco Plan - The planned eco-friendly classification: Pb-Free (RoHS), Pb-Free (RoHS Exempt), or Green (RoHS & no Sb/Br) - please check <http://www.ti.com/productcontent> for the latest availability information and additional product content details.

**TBD:** The Pb-Free/Green conversion plan has not been defined.

**Pb-Free (RoHS):** TI's terms "Lead-Free" or "Pb-Free" mean semiconductor products that are compatible with the current RoHS requirements for all 6 substances, including the requirement that lead not exceed 0.1% by weight in homogeneous materials. Where designed to be soldered at high temperatures, TI Pb-Free products are suitable for use in specified lead-free processes.

**Pb-Free (RoHS Exempt):** This component has a RoHS exemption for either 1) lead-based flip-chip solder bumps used between the die and package, or 2) lead-based die adhesive used between the die and leadframe. The component is otherwise considered Pb-Free (RoHS compatible) as defined above.

**Green (RoHS & no Sb/Br):** TI defines "Green" to mean Pb-Free (RoHS compatible), and free of Bromine (Br) and Antimony (Sb) based flame retardants (Br or Sb do not exceed 0.1% by weight in homogeneous material)

(3) MSL, Peak Temp. -- The Moisture Sensitivity Level rating according to the JEDEC industry standard classifications, and peak solder temperature.

(4) There may be additional marking, which relates to the logo, the lot trace code information, or the environmental category on the device.

(5) Multiple Device Markings will be inside parentheses. Only one Device Marking contained in parentheses and separated by a "~" will appear on a device. If a line is indented then it is a continuation of the previous line and the two combined represent the entire Device Marking for that device.

**Important Information and Disclaimer:** The information provided on this page represents TI's knowledge and belief as of the date that it is provided. TI bases its knowledge and belief on information provided by third parties, and makes no representation or warranty as to the accuracy of such information. Efforts are underway to better integrate information from third parties. TI has taken and continues to take reasonable steps to provide representative and accurate information but may not have conducted destructive testing or chemical analysis on incoming materials and chemicals. TI and TI suppliers consider certain information to be proprietary, and thus CAS numbers and other limited information may not be available for release.

In no event shall TI's liability arising out of such information exceed the total purchase price of the TI part(s) at issue in this document sold by TI to Customer on an annual basis.

**TAPE AND REEL INFORMATION**

**QUADRANT ASSIGNMENTS FOR PIN 1 ORIENTATION IN TAPE**

\*All dimensions are nominal

Device	Package Type	Package Drawing	Pins	SPQ	Reel Diameter (mm)	Reel Width W1 (mm)	A0 (mm)	B0 (mm)	K0 (mm)	P1 (mm)	W (mm)	Pin1 Quadrant
TAS5558DCAR	HTSSOP	DCA	56	2000	330.0	24.4	8.6	15.6	1.8	12.0	24.0	Q1

TAPE AND REEL BOX DIMENSIONS



\*All dimensions are nominal

Device	Package Type	Package Drawing	Pins	SPQ	Length (mm)	Width (mm)	Height (mm)
TAS5558DCAR	HTSSOP	DCA	56	2000	367.0	367.0	45.0

# MECHANICAL DATA

DCA (R-PDSO-G56)

PowerPAD™ PLASTIC SMALL-OUTLINE

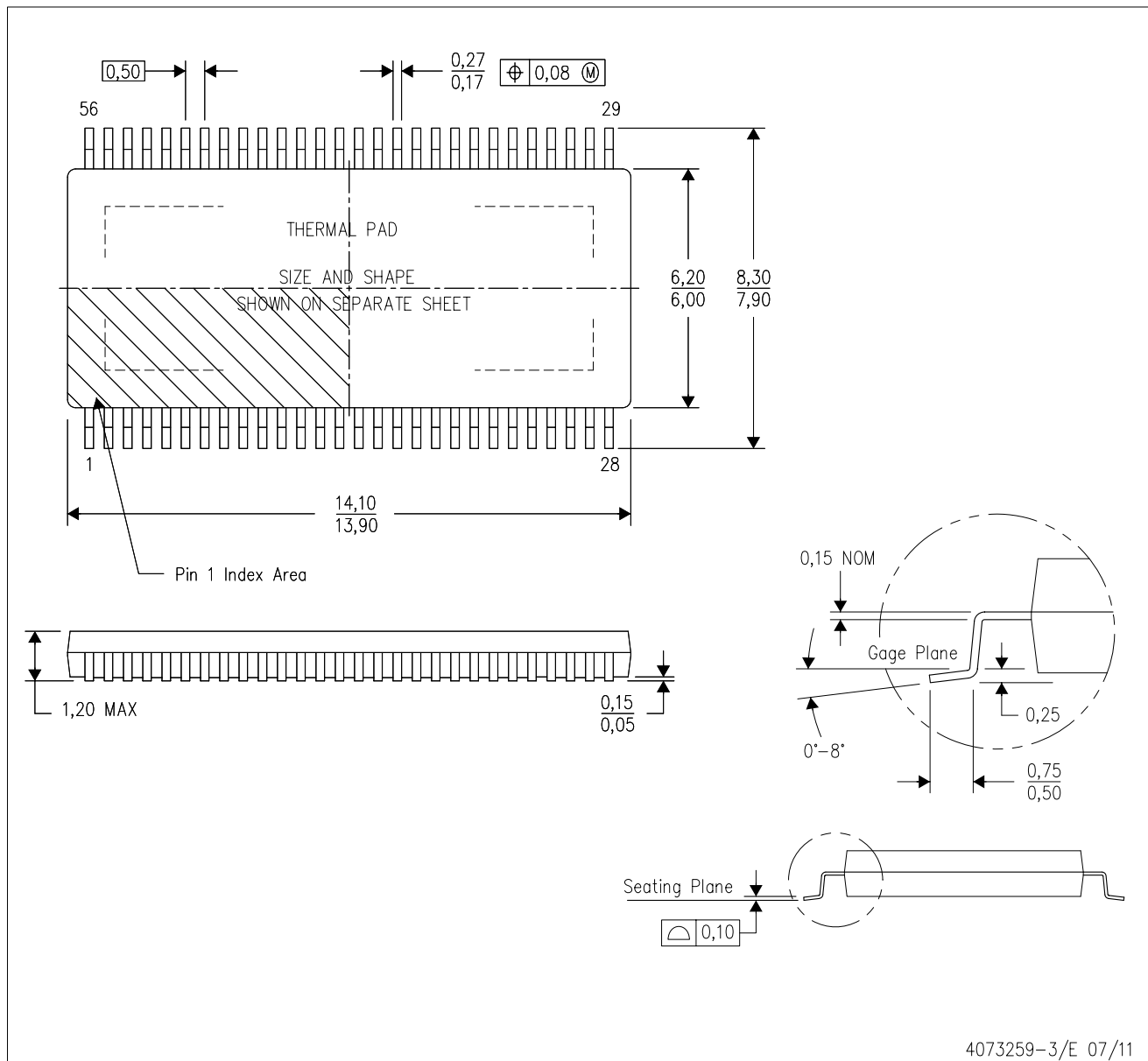

- NOTES:
- All linear dimensions are in millimeters. Dimensioning and tolerancing per ASME Y14.5M-1994.
  - This drawing is subject to change without notice.
  - Body dimensions do not include mold flash or protrusion not to exceed 0,15.
  - This package is designed to be soldered to a thermal pad on the board. Refer to Technical Brief, PowerPad Thermally Enhanced Package, Texas Instruments Literature No. SLMA002 for information regarding recommended board layout. This document is available at [www.ti.com](http://www.ti.com) <<http://www.ti.com>>.
  - See the additional figure in the Product Data Sheet for details regarding the exposed thermal pad features and dimensions.
  - Falls within JEDEC MO-153

PowerPAD is a trademark of Texas Instruments.



# THERMAL PAD MECHANICAL DATA

DCA (R-PDSO-G56)

PowerPAD™ PLASTIC SMALL OUTLINE

## THERMAL INFORMATION

This PowerPAD™ package incorporates an exposed thermal pad that is designed to be attached directly to an external heatsink. This design optimizes the heat transfer from the integrated circuit (IC).

For additional information on the PowerPAD package and how to take advantage of its heat dissipating abilities, refer to Technical Brief, PowerPAD Thermally Enhanced Package, Texas Instruments Literature No. SLMA002 and Application Brief, PowerPAD Made Easy, Texas Instruments Literature No. SLMA004. Both documents are available at [www.ti.com](http://www.ti.com).

The exposed thermal pad dimensions for this package are shown in the following illustration.

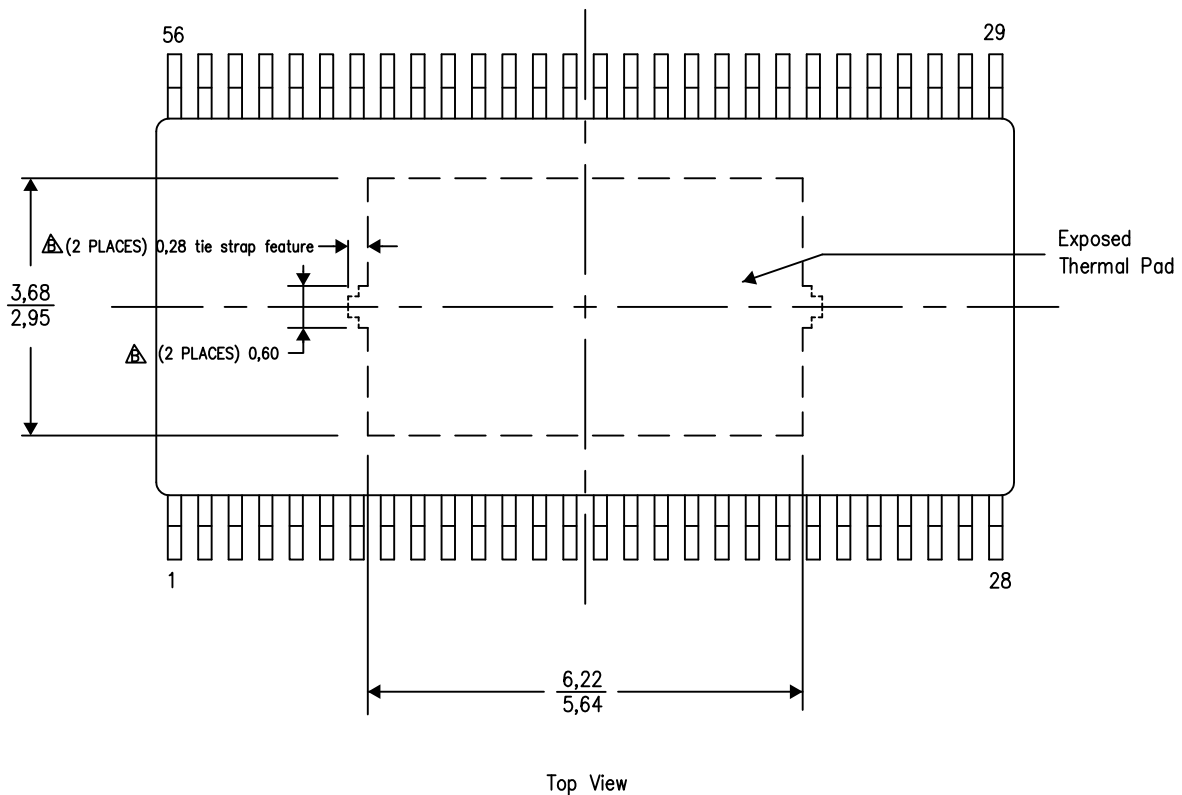

Exposed Thermal Pad Dimensions

4206320-13/R 03/13

NOTES: A. All linear dimensions are in millimeters

- △ Keep-out features are identified to prevent board routing interference. These exposed metal features may vary within the identified area or completely absent on some devices.

PowerPAD is a trademark of Texas Instruments.

## IMPORTANT NOTICE

Texas Instruments Incorporated and its subsidiaries (TI) reserve the right to make corrections, enhancements, improvements and other changes to its semiconductor products and services per JESD46, latest issue, and to discontinue any product or service per JESD48, latest issue. Buyers should obtain the latest relevant information before placing orders and should verify that such information is current and complete. All semiconductor products (also referred to herein as "components") are sold subject to TI's terms and conditions of sale supplied at the time of order acknowledgment.

TI warrants performance of its components to the specifications applicable at the time of sale, in accordance with the warranty in TI's terms and conditions of sale of semiconductor products. Testing and other quality control techniques are used to the extent TI deems necessary to support this warranty. Except where mandated by applicable law, testing of all parameters of each component is not necessarily performed.

TI assumes no liability for applications assistance or the design of Buyers' products. Buyers are responsible for their products and applications using TI components. To minimize the risks associated with Buyers' products and applications, Buyers should provide adequate design and operating safeguards.

TI does not warrant or represent that any license, either express or implied, is granted under any patent right, copyright, mask work right, or other intellectual property right relating to any combination, machine, or process in which TI components or services are used. Information published by TI regarding third-party products or services does not constitute a license to use such products or services or a warranty or endorsement thereof. Use of such information may require a license from a third party under the patents or other intellectual property of the third party, or a license from TI under the patents or other intellectual property of TI.

Reproduction of significant portions of TI information in TI data books or data sheets is permissible only if reproduction is without alteration and is accompanied by all associated warranties, conditions, limitations, and notices. TI is not responsible or liable for such altered documentation. Information of third parties may be subject to additional restrictions.

Resale of TI components or services with statements different from or beyond the parameters stated by TI for that component or service voids all express and any implied warranties for the associated TI component or service and is an unfair and deceptive business practice. TI is not responsible or liable for any such statements.

Buyer acknowledges and agrees that it is solely responsible for compliance with all legal, regulatory and safety-related requirements concerning its products, and any use of TI components in its applications, notwithstanding any applications-related information or support that may be provided by TI. Buyer represents and agrees that it has all the necessary expertise to create and implement safeguards which anticipate dangerous consequences of failures, monitor failures and their consequences, lessen the likelihood of failures that might cause harm and take appropriate remedial actions. Buyer will fully indemnify TI and its representatives against any damages arising out of the use of any TI components in safety-critical applications.

In some cases, TI components may be promoted specifically to facilitate safety-related applications. With such components, TI's goal is to help enable customers to design and create their own end-product solutions that meet applicable functional safety standards and requirements. Nonetheless, such components are subject to these terms.

No TI components are authorized for use in FDA Class III (or similar life-critical medical equipment) unless authorized officers of the parties have executed a special agreement specifically governing such use.

Only those TI components which TI has specifically designated as military grade or "enhanced plastic" are designed and intended for use in military/aerospace applications or environments. Buyer acknowledges and agrees that any military or aerospace use of TI components which have **not** been so designated is solely at the Buyer's risk, and that Buyer is solely responsible for compliance with all legal and regulatory requirements in connection with such use.

TI has specifically designated certain components as meeting ISO/TS16949 requirements, mainly for automotive use. In any case of use of non-designated products, TI will not be responsible for any failure to meet ISO/TS16949.

### Products

Audio	<a href="http://www.ti.com/audio">www.ti.com/audio</a>
Amplifiers	<a href="http://amplifier.ti.com">amplifier.ti.com</a>
Data Converters	<a href="http://dataconverter.ti.com">dataconverter.ti.com</a>
DLP® Products	<a href="http://www.dlp.com">www.dlp.com</a>
DSP	<a href="http://dsp.ti.com">dsp.ti.com</a>
Clocks and Timers	<a href="http://www.ti.com/clocks">www.ti.com/clocks</a>
Interface	<a href="http://interface.ti.com">interface.ti.com</a>
Logic	<a href="http://logic.ti.com">logic.ti.com</a>
Power Mgmt	<a href="http://power.ti.com">power.ti.com</a>
Microcontrollers	<a href="http://microcontroller.ti.com">microcontroller.ti.com</a>
RFID	<a href="http://www.ti-rfid.com">www.ti-rfid.com</a>
OMAP Applications Processors	<a href="http://www.ti.com/omap">www.ti.com/omap</a>
Wireless Connectivity	<a href="http://www.ti.com/wirelessconnectivity">www.ti.com/wirelessconnectivity</a>

### Applications

Automotive and Transportation	<a href="http://www.ti.com/automotive">www.ti.com/automotive</a>
Communications and Telecom	<a href="http://www.ti.com/communications">www.ti.com/communications</a>
Computers and Peripherals	<a href="http://www.ti.com/computers">www.ti.com/computers</a>
Consumer Electronics	<a href="http://www.ti.com/consumer-apps">www.ti.com/consumer-apps</a>
Energy and Lighting	<a href="http://www.ti.com/energy">www.ti.com/energy</a>
Industrial	<a href="http://www.ti.com/industrial">www.ti.com/industrial</a>
Medical	<a href="http://www.ti.com/medical">www.ti.com/medical</a>
Security	<a href="http://www.ti.com/security">www.ti.com/security</a>
Space, Avionics and Defense	<a href="http://www.ti.com/space-avionics-defense">www.ti.com/space-avionics-defense</a>
Video and Imaging	<a href="http://www.ti.com/video">www.ti.com/video</a>

### TI E2E Community

[e2e.ti.com](http://e2e.ti.com)