

FSA2257

Low R_{ON}, Low-Voltage Dual SPDT Bi-Directional Analog Switch

Features

- Maximum 1.15 Ω On Resistance (R_{ON}) at 4.5 V V_{CC}
- 0.3 Ω Maximum R_{ON} Flatness at +5 V V_{CC}
- Space-Saving MicroPak™
- Broad V_{CC} Operating Range: 1.65 V to 5.50 V
- Fast Turn-On and Turn-Off Time
- Break-Before-Make Enable Circuitry
- Over-Voltage Tolerant TTL-Compatible Control Input

Description

The FSA2257 is a high-performance bi-directional dual Single-Pole/Double-Throw (SPDT) analog switch. This switch can be configured as either a multiplexer or a de-multiplexer by select pins. The device features ultra-low R_{ON} of 1.3 Ω maximum at 4.5 V V_{CC} and operates over the wide V_{CC} range of 1.65 V to 5.50 V. The device is fabricated with submicron CMOS technology to achieve fast switching speeds and is designed for break-before-make operation. The select input is TTL-level compatible.

Applications

- Cell Phone
- PDA
- Mobile Devices

Ordering Information

Part Number	Package Number	Top Mark	Package Description	Packing Method
FSA2257L10X	MAC10A	EP	10-Lead MicroPak™, 1.6 x 2.1 mm	5000 Units Tape and Reel
FSA2257MTCX	MCT14	FSA2257	14-Lead Thin Shrink Small Outline Package (TSSOP), JEDEC MO-153, 4.4 mm Wide	2500 Units Tape and Reel
FSA2257MUX	MUA10A	FSA 2257	10-Lead Molded Small Outline Package (MSOP), JEDEC MO-187, 3.0 mm	4000 Units Tape and Reel

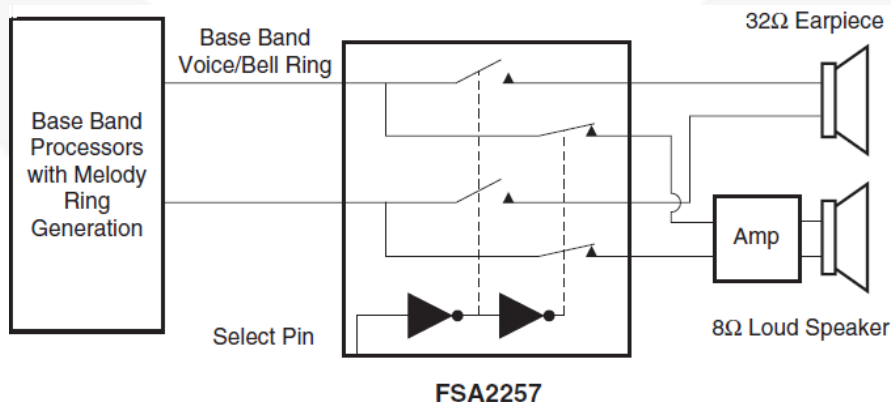

Figure 1. Block Diagram

Pin Configurations

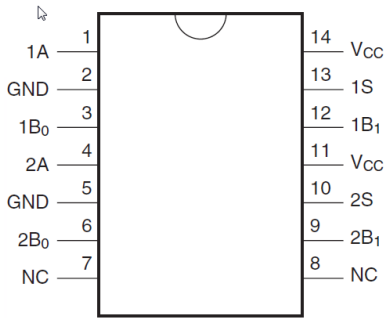

Figure 2. Pin Assignments for TSSOP (Top View)

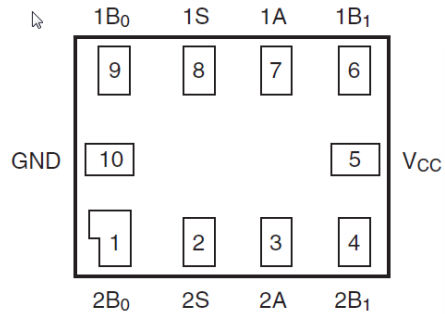

Figure 3. MicroPak™ Pad Assignments (Top View)

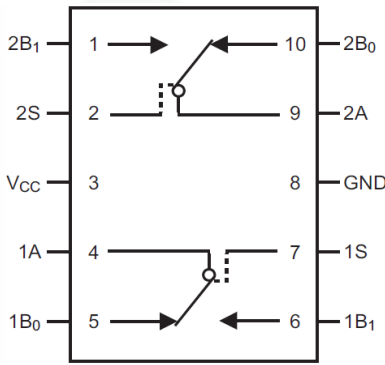

Figure 4. Pin Assignments for MSOP (Top View)

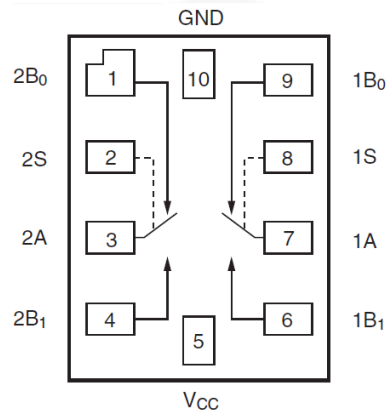

Figure 5. Analog Symbols (Top Through View)

Pin Definitions

Pin# TSSOP	Pin# MicroPak™	Pin # MSOP	Name	Description
1	7	4	1A	Data Ports
2,5	10	8	GND	Ground
3	9	5	1B ₀	Data Ports
4	3	9	2A	Data Ports
6	1	10	2B ₀	Data Ports
7,8			NC	No Connect
9	4	1	2B ₁	Data Ports
10	2	2	2S	Control Inputs
11,14	5	3	V _{CC}	Power Supply
12	6	6	1B ₁	Data Ports
13	8	7	1S	Control Inputs

Truth Table

Control Input (S)	Function
Low Logic Level	B ₀ connected to A
High Logic Level	B ₁ connected to A

Absolute Maximum Ratings

Stresses exceeding the absolute maximum ratings may damage the device. The device may not function or be operable above the recommended operating conditions and stressing the parts to these levels is not recommended. In addition, extended exposure to stresses above the recommended operating conditions may affect device reliability. The absolute maximum ratings are stress ratings only.

Symbol	Parameter	Min.	Max.	Unit
V _{CC}	Supply Voltage	-0.5	6.0	V
V _{SW}	DC Switch Voltage ⁽¹⁾	-0.5	V _{CC} + 0.5	V
V _{IN}	DC Input Voltage ⁽¹⁾	-0.5	6.0	V
I _{IK}	Input Diode Current	-50		mA
	Switch Current		200	
	Peak Switch Current (Pulsed at 1 ms duration, <10% duty cycle)		400	
T _{STG}	Storage Temperature Range	-65	+150	°C
T _J	Maximum Junction Temperature		+150	°C
T _L	Lead Temperature (Soldering, 10 seconds)		+260	°C
ESD	Electrostatic Discharge Capability	Human Body Model, JESD22-A114	8000	V
		Charged Device Model, JESD22-C101	2000	

Note:

1. Input and output negative ratings may be exceeded if input and output diode current ratings are observed.

Recommended Operating Conditions

The Recommended Operating Conditions table defines the conditions for actual device operation. Recommended operating conditions are specified to ensure optimal performance to the datasheet specifications. Fairchild does not recommend exceeding them or designing to Absolute Maximum Ratings.

Symbol	Parameter	Min.	Max.	Unit
V _{CC}	Supply Voltage	1.65	5.50	V
V _{CNTRL}	Control Input Voltage ⁽²⁾	0	V _{CC}	V
V _{SW}	Switch Input Voltage	0	V _{CC}	V
T _A	Operating Temperature	-40	+85	°C

Note:

2. Unused control input must be held HIGH or LOW and it must not float.

DC Electrical Characteristics

Typical values are at 25°C unless otherwise specified.

Symbol	Parameter	Conditions	V _{CC} (V)	T _A =+25°C			T _A =-40°C to +85°C		Unit
				Min.	Typ.	Max.	Min.	Max.	
V _{IH}	Input Voltage High		1.8 to 2.7				1.0		V
			2.7 to 3.6				2.0		
			4.5 to 5.5				2.4		
V _{IL}	Input Voltage Low		1.8 to 2.7					0.4	V
			2.7 to 3.6					0.6	
			4.5 to 5.5					0.8	
I _{IN}	Control Input Leakage	V _{IN} =0 V to V _{CC}	2.7 to 3.6				-1.0	1.0	μA
			4.5 to 5.5				-1.0	1.0	
I _{NO(OFF)} , I _{NC(OFF)}	Off Leakage Current of Port B ₀ and B ₁	A=1 V, 4.5 V, B ₀ or B ₁ =1 V, 4.5 V	5.5	-2		2	-20	20	nA
I _{A(ON)}	On Leakage Current of Port A	A=1 V, 4.5V, B ₀ or B ₁ =1 V, 4.5 V or Floating	5.5	-4		2	-40	40	nA
R _{ON}	Switch On Resistance MicroPak ⁽³⁾	I _{OUT} =100 mA, B ₀ or B ₁ =1.5 V	1.8		4.6				Ω
			2.7		2.6	4.0		4.3	
	Switch On Resistance MSOP/TSSOP ⁽³⁾	I _{OUT} =100 mA, B ₀ or B ₁ =3.5 V	4.5		0.95	1.15		1.30	
			2.7		2.8			4.5	
ΔR _{ON}	On Resistance Matching Between Channels MicroPak ⁽⁴⁾	I _{OUT} =100 mA, B ₀ or B ₁ =3.5 V	4.5		0.06	0.12		0.15	Ω
			4.5		0.7			0.3	
R _{FLAT(ON)}	On Resistance Flatness ⁽⁵⁾	I _{OUT} =100 mA, B ₀ or B ₁ =0 V, 0.75 V, 1.5 V	1.8		3.0				Ω
			2.7		1.4				
		I _{OUT} =100 mA, B ₀ or B ₁ =0 V, 1 V, 2 V	4.5		0.2	0.3		0.4	
I _{CC}	Quiescent Supply Current	V _{IN} =0 V or V _{CC} , I _{OUT} =0 V	3.6		0.1	0.5		1.0	μA
			5.5		0.1	0.5		1.0	

Notes:

- On resistance is determined by the voltage drop between A and B pins at the indicated current through the switch.
- ΔR_{ON} = R_{ONmax} – R_{ONmin} measured at identical V_{CC}, temperature, and voltage.
- Flatness is defined as the difference between the maximum and minimum value of on resistance over the specified range of conditions.

AC Electrical Characteristics

Typical values are at 25°C unless otherwise specified.

Symbol	Parameter	Conditions	V _{CC} (V)	T _A =+25°C			T _A =-40°C to +85°C		Unit	Figure
				Min.	Typ.	Max.	Min.	Max.		
t _{ON}	Turn-On Time	B ₀ or B ₁ =1.5 V, R _L =50 Ω, C _L =35 pF	1.8 to 2.7		75				ns	Figure 6
			2.7 to 3.6			50		60		
		B ₀ or B ₁ =3.0 V, R _L =50 Ω, C _L =35 pF	4.5 to 5.5			35		40		
t _{OFF}	Turn-Off Time	B ₀ or B ₁ =1.5 V, R _L =50 Ω, C _L =35 pF	1.8 to 2.7		20			ns	Figure 6	
			2.7 to 3.6			20				30
		B ₀ or B ₁ =3.0 V, R _L =50 Ω, C _L =35 pF	4.5 to 5.5			15				20
t _{BBM}	Break-Before-Make Time	B ₀ or B ₁ =1.5 V, R _L =50 Ω, C _L =35 pF	2.7 to 3.6				1	ns	Figure 7	
			4.5 to 5.5		20		1			
Q	Charge Injection	C _L =1.0 nF, V _{GEN} =0 V, R _{GEN} =0 Ω	2.7 to 3.6		20			pC	Figure 9	
			4.5 to 5.5		10					
OIRR	Off Isolation	f=1 MHz, R _L =50 Ω	2.7 to 3.6		-70			dB	Figure 8	
			4.5 to 5.5		-70					
Xtalk	Crosstalk	f=1 MHz, R _L =50 Ω	2.7 to 3.6		-75			dB	Figure 8	
			4.5 to 5.5		-75					
BW	-3 db Bandwidth	R _L =50 Ω	2.7 to 3.6		200			MHz	Figure 11	
			4.5 to 5.5		200					
THD	Total Harmonic Distortion	R _L =600 Ω, V _{IN} =0.5 V _{PP} f=20 Hz to 20 kHz	2.7 to 3.6		0.002			%	Figure 12	
			4.5 to 5.5		0.002					

Capacitance

Symbol	Parameter	Conditions	V _{CC} (V)	T _A =+25°C			Unit	Figure
				Min.	Typ.	Max.		
C _{IN}	Control Pin Input Capacitance	f=1 MHz	0		3.5		pF	Figure 10
C _{OFF}	B Port Off Capacitance	f=1 MHz	4.5		12.0		pF	Figure 10
C _{ON}	A Port On Capacitance	f=1 MHz	4.5		40.0		pF	Figure 10

AC Loadings and Waveforms

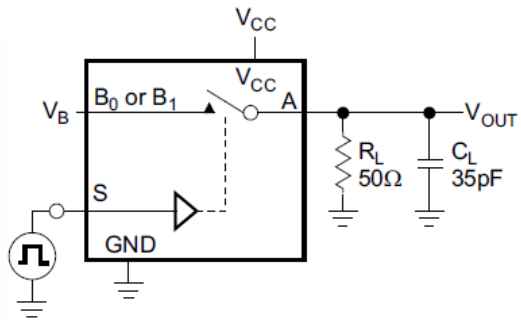

C_L Includes Fixture and Stray Capacitance

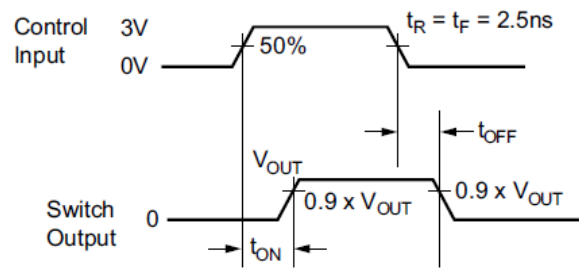

Logic Input Waveforms Inverted for Switches that have the Opposite Logic Sense

Figure 6. Turn On / Off Timing

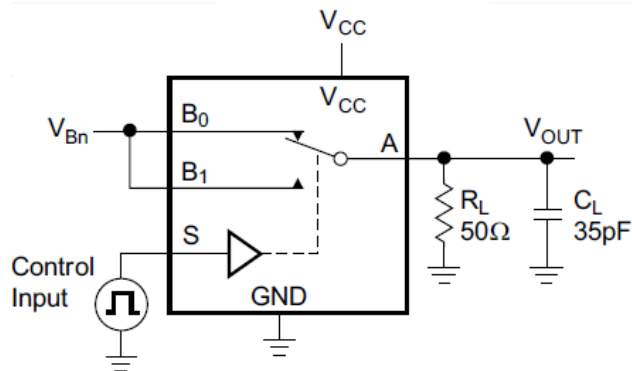

C_L Includes Fixture and Stray Capacitance

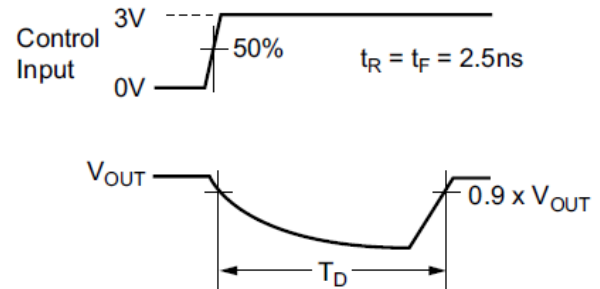
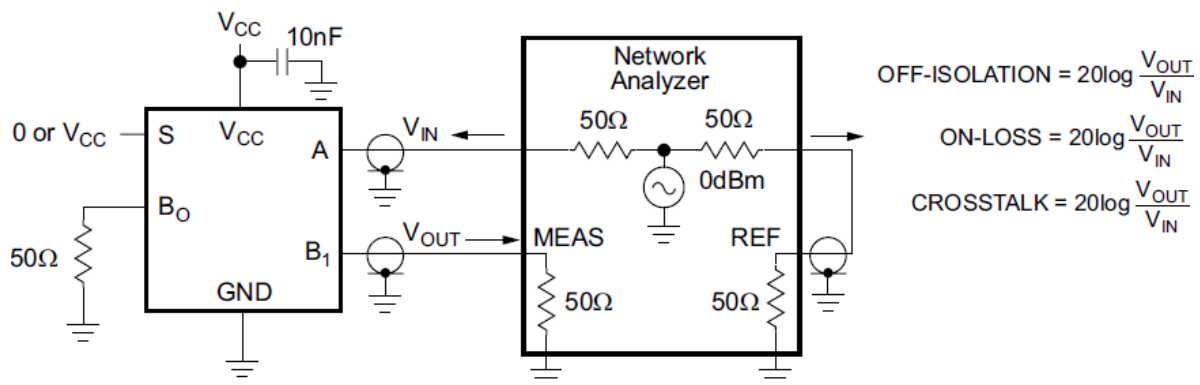

Figure 7. Break Before Make Timing



$$\text{OFF-ISOLATION} = 20 \log \frac{V_{\text{OUT}}}{V_{\text{IN}}}$$

$$\text{ON-LOSS} = 20 \log \frac{V_{\text{OUT}}}{V_{\text{IN}}}$$

$$\text{CROSSTALK} = 20 \log \frac{V_{\text{OUT}}}{V_{\text{IN}}}$$

Figure 8. Off Isolation and Crosstalk

AC Loadings and Waveforms (Continued)

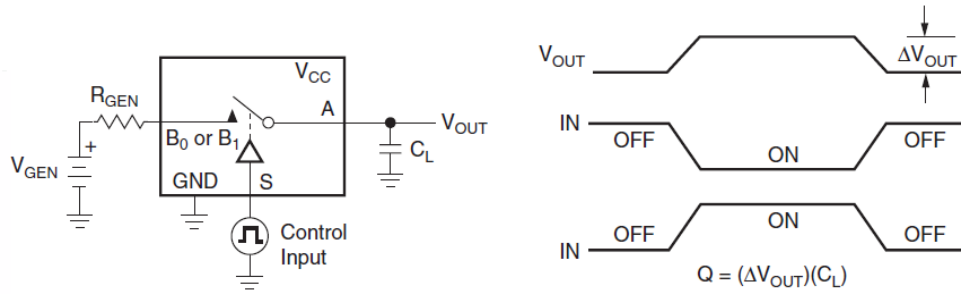

Figure 9. Charge Injection

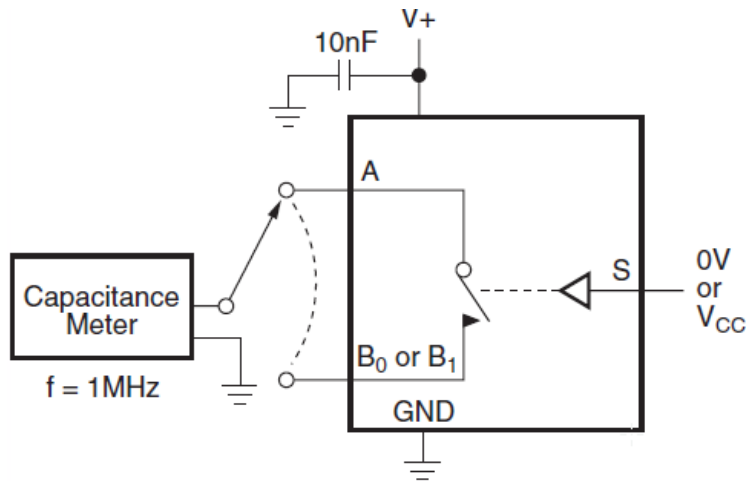

Figure 10. On / Off Capacitance Measurement Setup

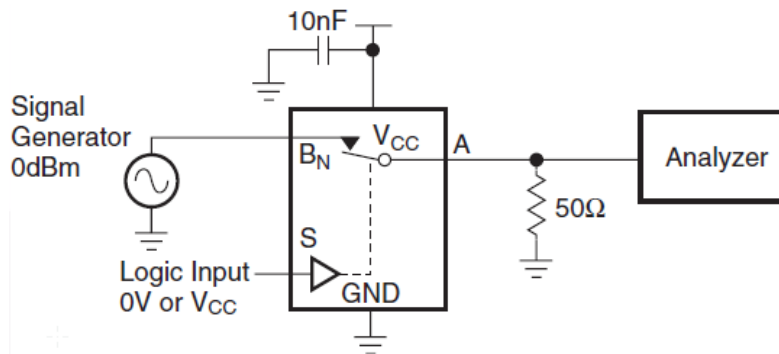

Figure 11. Bandwidth

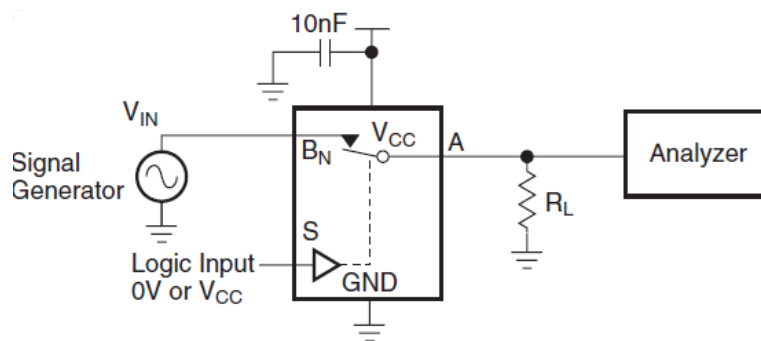

Figure 12. Harmonic Distortion

Physical Dimensions

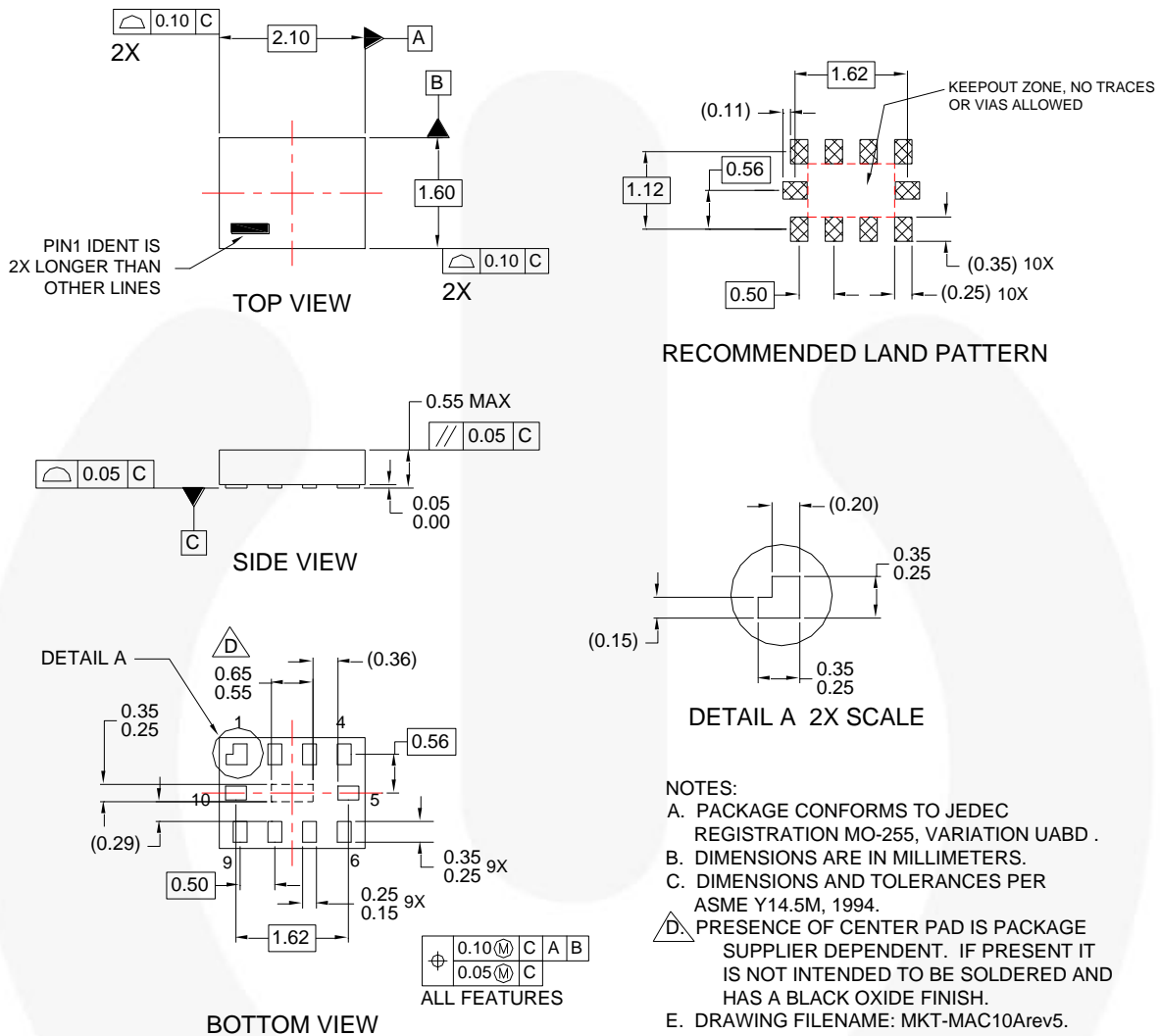

Figure 13. 10-Lead MicroPak, 1.6 x 2.1 mm

Package drawings are provided as a service to customers considering Fairchild components. Drawings may change in any manner without notice. Please note the revision and/or date on the drawing and contact a Fairchild Semiconductor representative to verify or obtain the most recent revision. Package specifications do not expand the terms of Fairchild's worldwide terms and conditions, specifically the warranty therein, which covers Fairchild products.

Always visit Fairchild Semiconductor's online packaging area for the most recent package drawings:
<http://www.fairchildsemi.com/packaging/>.

Tape and Reel Specifications

Please visit Fairchild Semiconductor's online packaging area for the most recent tape and reel specifications:
http://www.fairchildsemi.com/products/logic/pdf/micropak_tr.pdf.

Physical Dimensions (Continued)

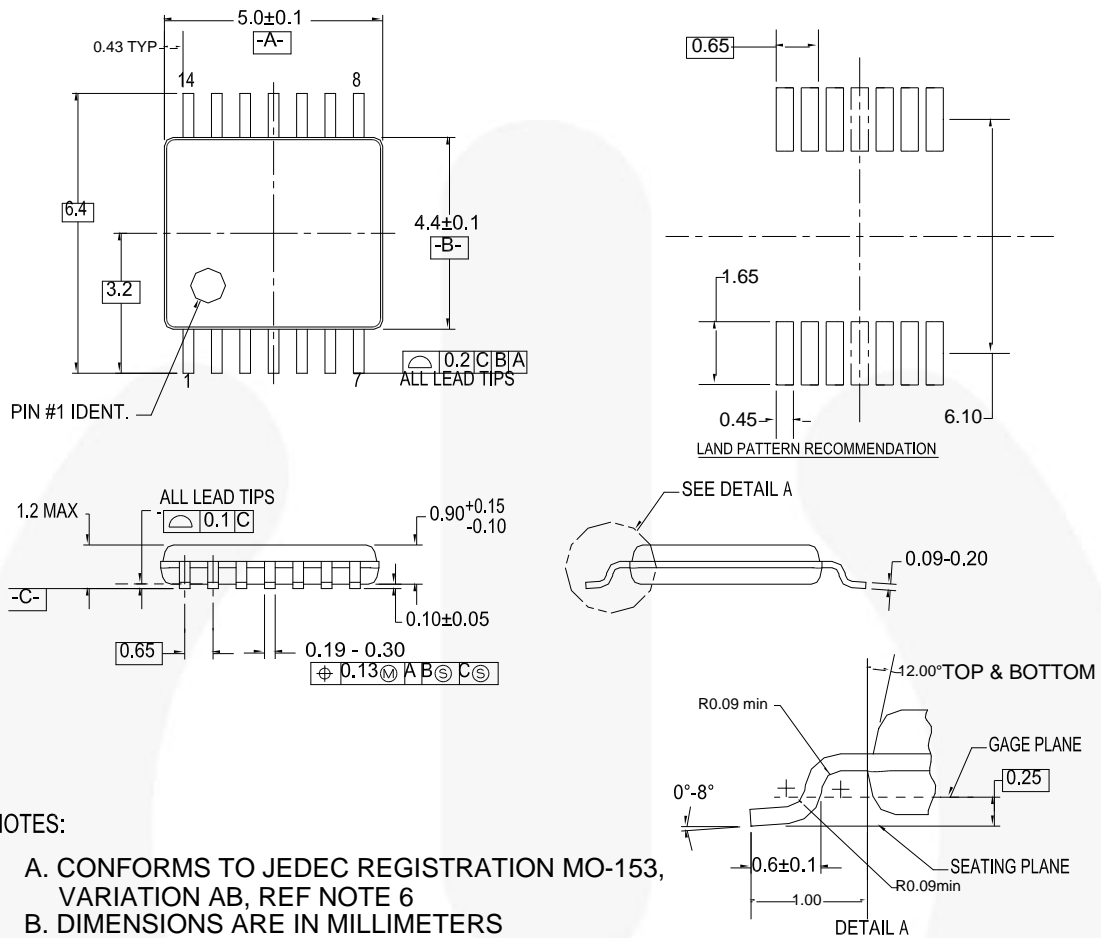

NOTES:

- A. CONFORMS TO JEDEC REGISTRATION MO-153, VARIATION AB, REF NOTE 6
- B. DIMENSIONS ARE IN MILLIMETERS
- C. DIMENSIONS ARE EXCLUSIVE OF BURRS, MOLD FLASH, AND TIE BAR EXTRUSIONS
- D. DIMENSIONING AND TOLERANCES PER ANSI Y14.5M, 1982
- E. LANDPATTERN STANDARD: SOP65P640X110-14M
- F. DRAWING FILE NAME: MTC14REV6

Figure 14. 14-Lead, Thin-Shrink Small Outline Package (TSSOP), JEDEC MO-153, 4.4 mm Wide

Package drawings are provided as a service to customers considering Fairchild components. Drawings may change in any manner without notice. Please note the revision and/or date on the drawing and contact a Fairchild Semiconductor representative to verify or obtain the most recent revision. Package specifications do not expand the terms of Fairchild's worldwide terms and conditions, specifically the warranty therein, which covers Fairchild products.

Always visit Fairchild Semiconductor's online packaging area for the most recent package drawings:
<http://www.fairchildsemi.com/packaging/>

Physical Dimensions (Continued)

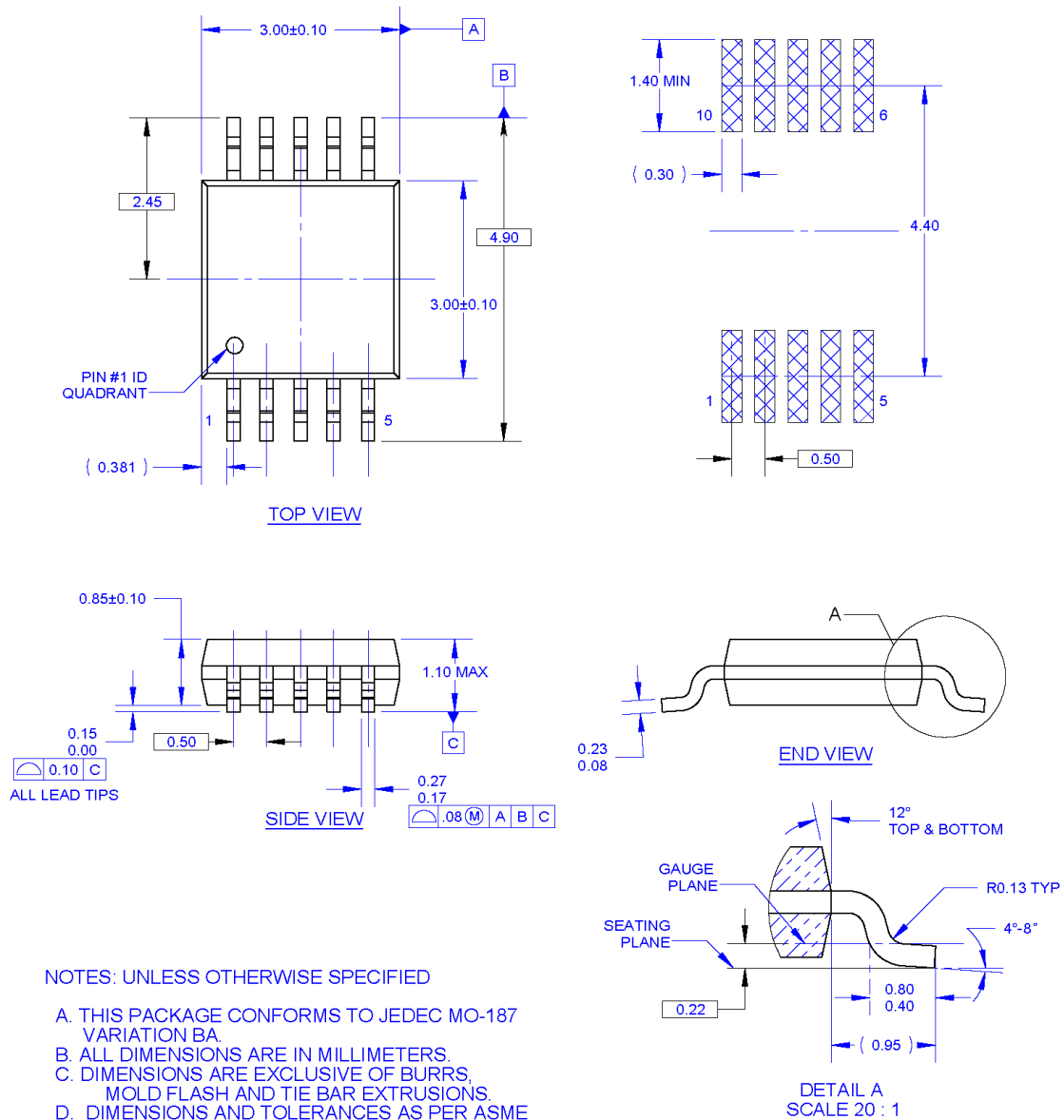

Figure 15. 10-Lead Molded Small Outline Package (MSOP), JEDEC MO-187, 3.0 mm

Package drawings are provided as a service to customers considering Fairchild components. Drawings may change in any manner without notice. Please note the revision and/or date on the drawing and contact a Fairchild Semiconductor representative to verify or obtain the most recent revision. Package specifications do not expand the terms of Fairchild's worldwide terms and conditions, specifically the warranty therein, which covers Fairchild products.

Always visit Fairchild Semiconductor's online packaging area for the most recent package drawings:
<http://www.fairchildsemi.com/packaging/>.

Tape and Reel Specifications

Please visit Fairchild Semiconductor's online packaging area for the most recent tape and reel specifications:
http://www.fairchildsemi.com/products/analog/pdf/msop10_tr.pdf.

TRADEMARKS

The following includes registered and unregistered trademarks and service marks, owned by Fairchild Semiconductor and/or its global subsidiaries, and is not intended to be an exhaustive list of all such trademarks.

- | | | | |
|---|--|---|---|
| 2Cool™ | FPS™ |  | Sync-Lock™ |
| AccuPower™ | F-PFS™ | PowerTrench® |  |
| AX-CAP®* | FRFET® | PowerXS™ | TinyBoost™ |
| BitSiC™ | Global Power Resource™ | Programmable Active Droop™ | TinyBuck™ |
| Build it Now™ | GreenBridge™ | QFET® | TinyCalc™ |
| CorePLUSTM | Green FPS™ | QST™ | TinyLogic® |
| CorePOWER™ | Green FPS™ e-Series™ | Quiet Series™ | TINYOPTO™ |
| CROSSVOLT™ | Gmax™ | RapidConfigure™ | TinyPower™ |
| CTL™ | GTO™ |  | TinyPWM™ |
| Current Transfer Logic™ | IntelliMAX™ | Saving our world, 1mV/WkV at a time™ | TinyWire™ |
| DEUXPEED® | ISOPLANAR™ | SignalWise™ | TranSiC™ |
| Dual Cool™ | Making Small Speakers Sound Louder and Better™ | SmartMax™ | TriFault Detect™ |
| EcoSPARK® | MegaBuck™ | SMART START™ | TRUECURRENT®* |
| EfficientMax™ | MICROCOUPLER™ | Solutions for Your Success™ | µSerDes™ |
| ESBC™ | MicroFET™ | SPM® |  |
|  | MicroPak™ | STEALTH™ | UHC® |
| Fairchild® | MicroPak2™ | SuperFET® | Ultra FRFET™ |
| Fairchild Semiconductor® | MillerDrive™ | SuperSOT™-3 | UniFET™ |
| FACT Quiet Series™ | MotionMax™ | SuperSOT™-6 | VCX™ |
| FACT® | mWSaver™ | SuperSOT™-8 | VisualMax™ |
| FAST® | OptoHiT™ | SupreMOS® | VoltagePlus™ |
| FastvCore™ | OPTOLOGIC® | SyncFET™ | XS™ |
| FETBench™ | OPTOPLANAR® | | |

* Trademarks of System General Corporation, used under license by Fairchild Semiconductor.

DISCLAIMER

FAIRCHILD SEMICONDUCTOR RESERVES THE RIGHT TO MAKE CHANGES WITHOUT FURTHER NOTICE TO ANY PRODUCTS HEREIN TO IMPROVE RELIABILITY, FUNCTION, OR DESIGN. FAIRCHILD DOES NOT ASSUME ANY LIABILITY ARISING OUT OF THE APPLICATION OR USE OF ANY PRODUCT OR CIRCUIT DESCRIBED HEREIN, NEITHER DOES IT CONVEY ANY LICENSE UNDER ITS PATENT RIGHTS, NOR THE RIGHTS OF OTHERS. THESE SPECIFICATIONS DO NOT EXPAND THE TERMS OF FAIRCHILD'S WORLDWIDE TERMS AND CONDITIONS, SPECIFICALLY THE WARRANTY THEREIN, WHICH COVERS THESE PRODUCTS.

LIFE SUPPORT POLICY

FAIRCHILD'S PRODUCTS ARE NOT AUTHORIZED FOR USE AS CRITICAL COMPONENTS IN LIFE SUPPORT DEVICES OR SYSTEMS WITHOUT THE EXPRESS WRITTEN APPROVAL OF FAIRCHILD SEMICONDUCTOR CORPORATION.

As used herein:

- Life support devices or systems are devices or systems which, (a) are intended for surgical implant into the body or (b) support or sustain life, and (c) whose failure to perform when properly used in accordance with instructions for use provided in the labeling, can be reasonably expected to result in a significant injury of the user.
- A critical component in any component of a life support, device, or system whose failure to perform can be reasonably expected to cause the failure of the life support device or system, or to affect its safety or effectiveness.

ANTI-COUNTERFEITING POLICY

Fairchild Semiconductor Corporation's Anti-Counterfeiting Policy. Fairchild's Anti-Counterfeiting Policy is also stated on our external website, www.fairchildsemi.com, under Sales Support.

Counterfeiting of semiconductor parts is a growing problem in the industry. All manufacturers of semiconductor products are experiencing counterfeiting of their parts. Customers who inadvertently purchase counterfeit parts experience many problems such as loss of brand reputation, substandard performance, failed applications, and increased cost of production and manufacturing delays. Fairchild is taking strong measures to protect ourselves and our customers from the proliferation of counterfeit parts. Fairchild strongly encourages customers to purchase Fairchild parts either directly from Fairchild or from Authorized Fairchild Distributors who are listed by country on our web page cited above. Products customers buy either from Fairchild directly or from Authorized Fairchild Distributors are genuine parts, have full traceability, meet Fairchild's quality standards for handling and storage and provide access to Fairchild's full range of up-to-date technical and product information. Fairchild and our Authorized Distributors will stand behind all warranties and will appropriately address any warranty issues that may arise. Fairchild will not provide any warranty coverage or other assistance for parts bought from Unauthorized Sources. Fairchild is committed to combat this global problem and encourage our customers to do their part in stopping this practice by buying direct or from authorized distributors.

PRODUCT STATUS DEFINITIONS

Definition of Terms

Datasheet Identification	Product Status	Definition
Advance Information	Formative / In Design	Datasheet contains the design specifications for product development. Specifications may change in any manner without notice.
Preliminary	First Production	Datasheet contains preliminary data; supplementary data will be published at a later date. Fairchild Semiconductor reserves the right to make changes at any time without notice to improve design.
No Identification Needed	Full Production	Datasheet contains final specifications. Fairchild Semiconductor reserves the right to make changes at any time without notice to improve the design.
Obsolete	Not In Production	Datasheet contains specifications on a product that is discontinued by Fairchild Semiconductor. The datasheet is for reference information only.

Rev. 164