

DIMENSIONING AND TOLERANCING PER ASME Y14.5M (ISO STANDARDS). THIS DRAWING IS A CONTROLLED DOCUMENT.

| TOOL NUMBER | WIRE SIZE mm ² [AWG] | INSULATION DIAMETER mm [in.] | INSUL. ADJ. | FLIP LOCATOR | STRIP LENGTH mm [in.] | CRIMP HEIGHT mm [in.] | CONTACT PART NUMBERS | | | | CONTACT DESCRIP. | APPLIC. SPECIF. |
|-----------------------------------|---|--|-----------------|------------------|--|--|--|--|--|----------------------------------|------------------|-----------------|
| | | | | | | | LOOSE PIECE | | STRIP FORM | | | |
| 91500-1 91500-3 91500-4 | 0.5 - 0.9 [20-18] 1.2 - 2.1 [16-14] | 1.52 - 3.30 [.060 - .130] | YES | NO | 4.75 ± 0.38 [.187 ± .015] | 1.27 ± 0.05 [.050 ± .002] 1.60 ± 0.05 [.063 ± .002] | 350547-[] 350550-[] 350669-[] 350705-[] 770250-[] 770251-[] 770254-[] | 350218-[] 350536-[] 350654-[] 350687-[] 770007-[] 770008-[] 770193-[] | Univ. MATE-N-LOK Contacts Univ. MATE-N-LOK 2 Contacts | 114-1010 & 114-1011 114-1043 | | |
| 91506-1 91506-3 | 1.21 - 2.1 [16-14] | 3.3 - 5.1 [.130 - .200] | YES | NO | 4.75 ± 0.38 [.187 ± .015] | 1.60 ± 0.05 [.063 ± .002] | 350551-[] 350552-[] 350707-[] 350919-[] 350918-[] 770249-[] 770248-[] 770255-[] | 350537-[] 350538-[] 350700-[] 350874-[] 350873-[] 770006-[] 770005-[] 770194-[] | Univ. MATE-N-LOK Contacts Univ. MATE-N-LOK 2 Contacts | 114-1010 & 114-1011 114-1043 | | |
| 91508-1 91508-3 | 0.5 - 0.9 [20-18] | 3.3 - 5.1 [.130 - .200] | YES | NO | 4.75 ± 0.38 [.187 ± .015] | 1.24 ± 0.05 [.049 ± .002] | 350551-[] 350552-[] 350707-[] 350919-[] 350918-[] 770249-[] 770248-[] 770255-[] | 350537-[] 350538-[] 350700-[] 350874-[] 350873-[] 770006-[] 770005-[] 770194-[] | Univ. MATE-N-LOK Contacts Univ. MATE-N-LOK 2 Contacts | 114-1010 & 114-1011 114-1043 | | |
| 91510-1 91510-3 | 0.2 - 0.38 [24-22] 0.5 - 0.9 [20-18] | 1.02 - 2.54 [.040 - .100] | YES | NO | 4.75 ± 0.38 [.187 ± .015] | 1.02 ± 0.05 [.040 ± .002] 1.17 ± 0.05 [.046 ± .002] | 350689-[] 350690-[] 350706-[] 640347-[] 770252-[] 770253-[] | 350570-[] 350561-[] 350699-[] 350851-[] 770009-[] 770010-[] | Univ. MATE-N-LOK Contacts Univ. MATE-N-LOK 2 Contacts | 114-1010 & 114-1011 114-1043 | | |
| 91522-1 91522-3 | 0.32 - 0.6 [22-20] (1 wire) 0.8-0.9 [18] (2 wire) 0.31-0.38 [22] | 1.50 - 2.2 [.059 - .087] (1 wire) 1.54-2.4 [.059-.095] (2 wire) 1.5-1.7 [.059-.067] | YES | NO | 3.45 ± 0.25 [.136 ± .010] (1 wire) 3.45 ± 0.25 [.136 ± .010] (2 wire) 3.7 ± 0.2 [.146 ± .008] | 0.79 ± 0.05 [.031 ± .002] 1.04 ± 0.05 [.041 ± .002] | 170364-[] 170366-[] 770987-[] 770988-[] 794228-[] 794229-[] | 170360-[] 170362-[] 770903-[] 770904-[] 794220-[] 794221-[] | Mini-Univ. MATE-N-LOK Contacts Mini-Univ. MATE-N-LOK 2 Contacts | 114-5050 & 114-16017 114-1111 | | |
| 91529-1 91529-3 | 0.12 - 0.24 [26-24] 0.32 - 0.38 [22] | 1.2 - 1.75 [.047 - .069] | YES | YES | 3.45 ± 0.25 [.136 ± .010] | 0.69 ± 0.05 [.027 ± .002] 0.79 ± 0.05 [.031 ± .002] | 170363-[] 170365-[] 770985-[] 770986-[] 794226-[] 794227-[] | 170359-[] 170361-[] 770901-[] 770902-[] 794136-[] 794218-[] 794219-[] | Mini-Univ. MATE-N-LOK Contacts Mini-Univ. MATE-N-LOK 2 Contacts | 114-5050 & 114-16017 114-1111 | | |
| 91536-1 91536-3 | 0.5 - 0.9 [20-18] (1 wire) 1.2-1.4 [16] (2 wire) 0.5-0.6 [20] | 2.0 - 3.0 [.079 - .118] (1 wire) 2.5-3.2 [.098-.126] (2 wire) 2.0-2.4 [.079-.094] | YES | NO | 3.45 ± 0.25 [.136 ± .010] (1 wire) 3.45 ± 0.25 [.136 ± .010] (2 wire) 3.70 ± 0.20 [.146 ± .008] | 1.07 ± 0.05 [.042 ± .002] 1.27 ± 0.05 [.050 ± .002] | 171638-[] 171639-[] | 171636-[] 171637-[] | Mini-Univ. MATE-N-LOK Contacts | 114-5050 & 114-16017 | | |
| 91594-1 91594-3 | 0.50-0.89 [20-18] 0.50-1.42x2 [16-20x2] | 2.00-3.20 [.079-.126] 2.26-3.20 [.098-.126] | YES | NO | (1 wire) 3.45 ± 0.25 [.136 ± .010] (2 wire) 3.70 ± 0.20 [.146 ± .008] | 1.07 ± 0.05 [.042 ± .002] 1.29 ± 0.05 [.051 ± .002] | 794230-[] 794231-[] | 794222-[] 794223-[] | Mini-Univ. MATE-N-LOK 2 Contacts | 114-1111 | | |

LIST OF APPLIED CONTACT PART NUMBERS MAY NOT BE COMPLETE AND IS SUBJECT TO CHANGE. FOR CURRENT INFORMATION ON TERMINAL PART NUMBERS, CONTACT THE TOOLING ASSISTANCE CENTER : 1-800-722-1111.

2. AMP, CERTI-CRIMP, and MATE-N-LOK are trademarks.

-1 IS A CERTICRIMP II HAND TOOL ASSEMBLY.
-3 IS A CERTICRIMP II HEAD SUB-ASSEMBLY.

SUPERSEDED

-4 IS A CERTICRIMP II HAND TOOL ASSEMBLY FOR SMALL INSULATION DIAMETER.





6. THE HAND TOOL INSTRUCTION SHEET, ALSO KNOWN AS AN "IS", FOR MOST CERTI-CRIMP II TOOLS USE IS 408-8547. IF THE TOOL HAS A FLIP LOCATOR USE IS 408-10414.

CERTI-CRIMP II DATA SHEET

| | | | | | |
|---|--|--|--|--|--|
| DWN: M.YOUNGER 21FEB2012 | | MATERIAL: - | | HEAT TREAT: - | |
| CHK: B.A.WOLFE 22FEB2012 | | APVD: B.A. WOLFE 22FEB2012 | | TE Connectivity | |
| NAME: B.A. WOLFE | | SCALE: - | | | |
| DIMENSIONS: mm | | TOLERANCES UNLESS OTHERWISE SPECIFIED: | | SURFACE TEXTURE: | |
| 0 PLC ± - 1 PLC ± - 2 PLC ± - 3 PLC ± - 4 PLC ± - | | ANGLE: - SURFACE TEXTURE: | | SCALE: - SIZE: A1 DRAWING NO: 1583000 SHEET: 1 OF 2 REV: C | |
| C REVISED P LTR REVISION RECORD | | DATE: 1-2013 DWN: MY BAW | | REVISION RECORD | |

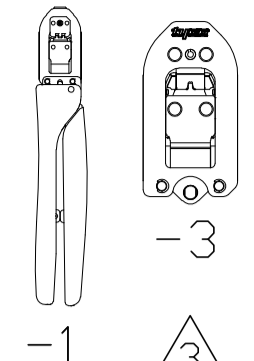
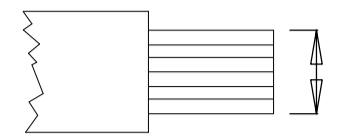
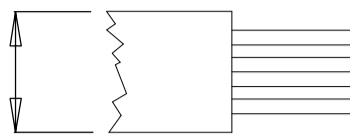
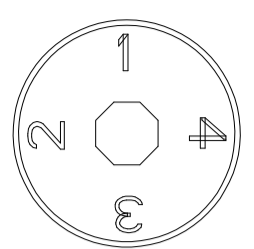
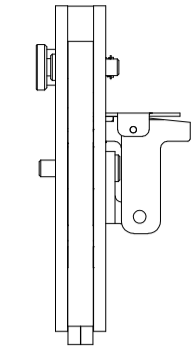
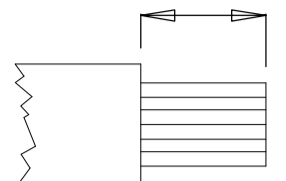
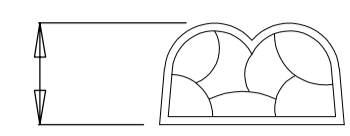
LOC: A
DIST: 00

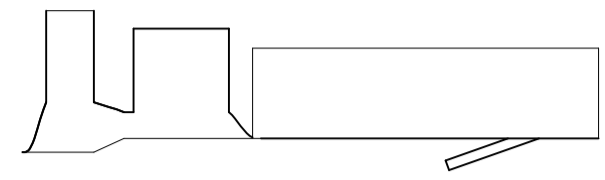
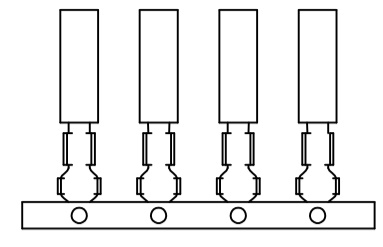
DIMENSIONING AND TOLERANCING PER ASME Y14.5M (ISO STANDARDS). THIS DRAWING IS A CONTROLLED DOCUMENT. P/N 1583000

| TOOL NUMBER  | WIRE SIZE mm ² [AWG]  | INSULATION DIAMETER mm [in.]  | INSUL. ADJ.  | FLIP LOCATOR  | STRIP LENGTH mm [in.]  | CRIMP HEIGHT mm [in.]  | CONTACT PART NUMBERS  | | CONTACT DESCRIP. | APPLIC. SPECIF. |
|---|---|--|--|---|---|---|---|---|-------------------------------------|------------------------|
| | | | | | | | LOOSE PIECE  | STRIP FORM  | | |
|  91574-1 | 0.20-0.56 [24-20] | 1.52-2.54 [.060-.100] | YES | NO | 5.16 ± 0.38 [.203 ± .015] | 1.05 ± 0.08 [.041 ± .003] | 350689-[] | 350570-[] | Universal MATE-N-LOK Contacts | 114-1010 & 114-1011 |
| | 0.75-0.89 [18] | | | | | | 350690-[] | 350561-[] | | |
|  91575-1 91575-3 | 0.50-0.89 [20-18] | 2.54-3.31 [.100-.130] | YES | NO | 5.16 ± 0.38 [.203 ± .015] | 1.29-1.45 [.051-.057] | 350547-[] | 350218-[] | Universal MATE-N-LOK Contacts | 114-1010 & 114-1011 |
| | 0.75+0.75 OR 0.75+1.25 [18+18 OR 18+16] | | | | | | 350705-[] | 350687-[] | | |
| 1976176-1 | 18 GA SOLID | 1.02-2.54 [.040-.100] | YES | NO | 4.37-0.38 [.172-.015] | 1.18 ± .025 [.044 ± .001] | 350689-[] 350550-[] 350690-[] 350547-[] | 350851-[] 350536-[] 350561-[] 350218-[] | Universal MATE-N-LOK Contacts | 114-1010 & 114-1011 |

 LIST OF APPLIED CONTACT PART NUMBERS MAY NOT BE COMPLETE AND IS SUBJECT TO CHANGE. FOR CURRENT INFORMATION ON TERMINAL PART NUMBERS, CONTACT THE TOOLING ASSISTANCE CENTER : 1-800-722-1111.

2. AMP, CERTI-CRIMP, and MATE-N-LOK are trademarks.

 -1 IS A CERTICRIMP II HAND TOOL ASSEMBLY. -3 IS A CERTICRIMP II HEAD SUB-ASSEMBLY.

 SUPERSEDED

 -4 IS A CERTICRIMP II HAND TOOL ASSEMBLY FOR SMALL INSULATION DIAMETER.

6. THE HAND TOOL INSTRUCTION SHEET, ALSO KNOWN AS AN "IS", FOR MOST CERTI-CRIMP II TOOLS USE IS 408-8547. IF THE TOOL HAS A FLIP LOCATOR USE IS 408-10414.

CERTI-CRIMP II DATA SHEET

| | | | |
|---|----------|---|--------------------|
| DWN: M.YOUNGER 21FEB2012 | | MATERIAL: - | HEAT TREAT: - |
| CHK: B.A.WOLFE 22FEB2012 | |  | |
| APVD: B.A. WOLFE 22FEB2012 | | | |
| NAME: CERTI-CRIMP II TOOL DATA SHEET UNIVERSAL MATE-N-LOK CONTACT FAMILY | | | |
| SCALE: - | SIZE: A1 | DRAWING NO: 1583000 | SHEET 2 OF 2 REV C |

LOC: A
DIST: 00