

(5x2,54= 12,7)

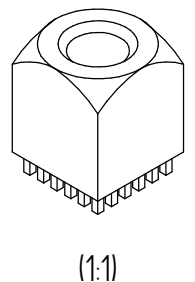

Surface coating 5-10µm Sn on 2-4µm Cu

(PROJECTION)		(TOLERANCES)	DIN ISO 2768-m			(SURFACE)	SCALE	2:1	TOTAL WEIGHT: 31,5 g
			(MATERIAL)	CuZn39Pb3			WEIGHT Cu: 0,0665 g	WEIGHT Sn: 0,1361 g	
F			DATE	NAME	(TITLE)	Bush with threaded hole M10 full plain Pin-Plate			
		DRAWN	2009/07/14	Dino Cantara					
		VERIFIED	2009/07/14	Heiko Schmid					
					(DRAWING NUMBER)	7461061		Sheet 1	
								1	
ISSUE	CHANGE	DATE	NAME		CONFIDENTIAL !! ALL RIGHTS RESERVED. Passing on or duplication without prior written agreement prohibited.				

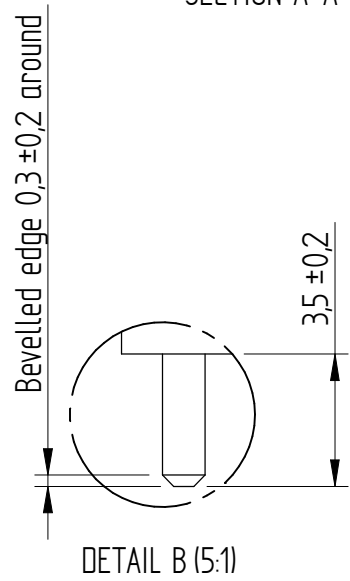
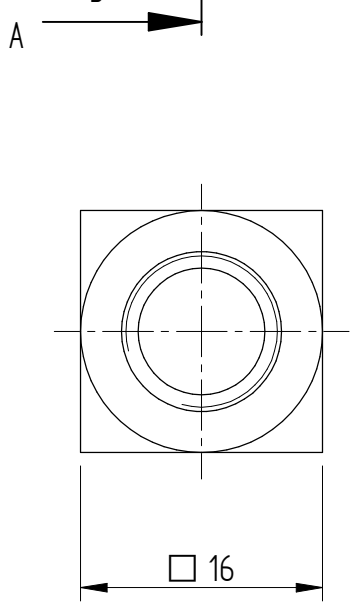
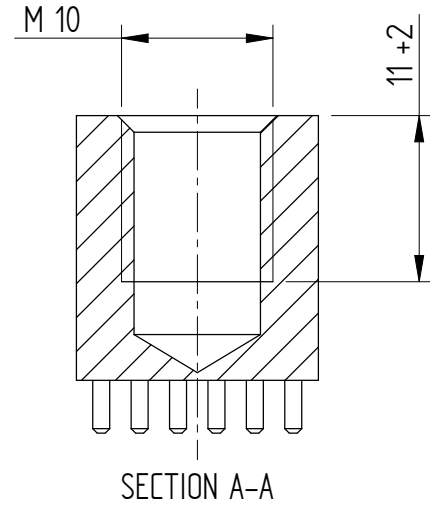
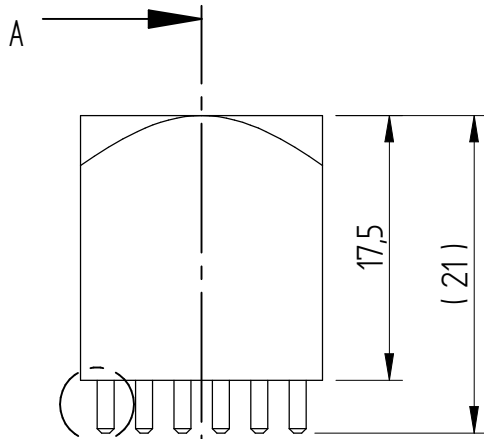