

TIWi-UB1 EM BOARD

User Guide



Last updated

August 14th, 2013

The information in this document is subject to change without notice.



Table of Contents

1	Introduction	3
1.1	<i>Purpose & Scope</i>	3
1.2	<i>Applicable Documents</i>	3
1.3	<i>Revision History</i>	3
2	TiWi-uB1 EM Board Description.....	4
3	TiWi-uB1 EM Board Hardware.....	6
3.1	<i>RF Connector.....</i>	6
3.2	<i>EM Interface Connectors</i>	6
3.3	<i>General Purpose Connectors</i>	9
3.4	<i>Power Configuration Jumpers.....</i>	11
3.5	<i>LED Indicators.....</i>	11
3.6	<i>Push Button Switches</i>	11
3.7	<i>Connecting EM Board to Host Platform.....</i>	12
3.8	<i>I²C Interface</i>	13
4	TiWi-uB1 EM Board Schematic	14
4.1	<i>Bill Of Material (BOM)</i>	15
5	Application Development	16
5.1	<i>Overview</i>	16
5.2	<i>Development Tools</i>	16
5.3	<i>Software Development.....</i>	25
6	Contacting LS Research	26

The information in this document is subject to change without notice.



1 Introduction

1.1 Purpose & Scope

The purpose of this document is to provide details regarding the setup and use of the TiWi-uB1 module on an EM board. This document covers a description of the EM board and its features and a brief tutorial on how to operate the module EM board.

1.2 Applicable Documents

- *TiWi-uB1 Datasheet (330-0132)*
- *TiWi-uB1 Antenna Design Guide (330-0133)*

1.3 Revision History

Date	ECN	Change Description	Revision
8/14/2013	87-2013	Initial release	1.0

Table 1 Revision History

2 TiWi-uB1 EM Board Description

The TiWi-uB1 EM “Evaluation Module” Board is an evaluation platform for the LS Research TiWi-uB1 Bluetooth Smart module. The TiWi-uB1 EM Board provides all of the necessary connectors, jumpers, indicators and switches to test and debug all aspects of the TiWi-uB1 module. The EM board is intended for evaluation purposes when used by itself or in conjunction with various Texas Instruments development boards. When used by itself, an on board coin cell battery or external power supply is used to power the TiWi-uB1 and its various peripherals.

The TiWi-uB1 EM board can be used to evaluate basic BLE connectivity. Additionally it is possible to put the TiWi-uB1 module into static RF test modes so that RF performance can be evaluated. Either a Texas Instruments CC Debugger or SmartRF05EB is required to be used in conjunction with the EM board for programming and debugging. The CC Debugger and SmartRF05EB are not provided by LSR and need to be purchased separately from Texas Instruments.

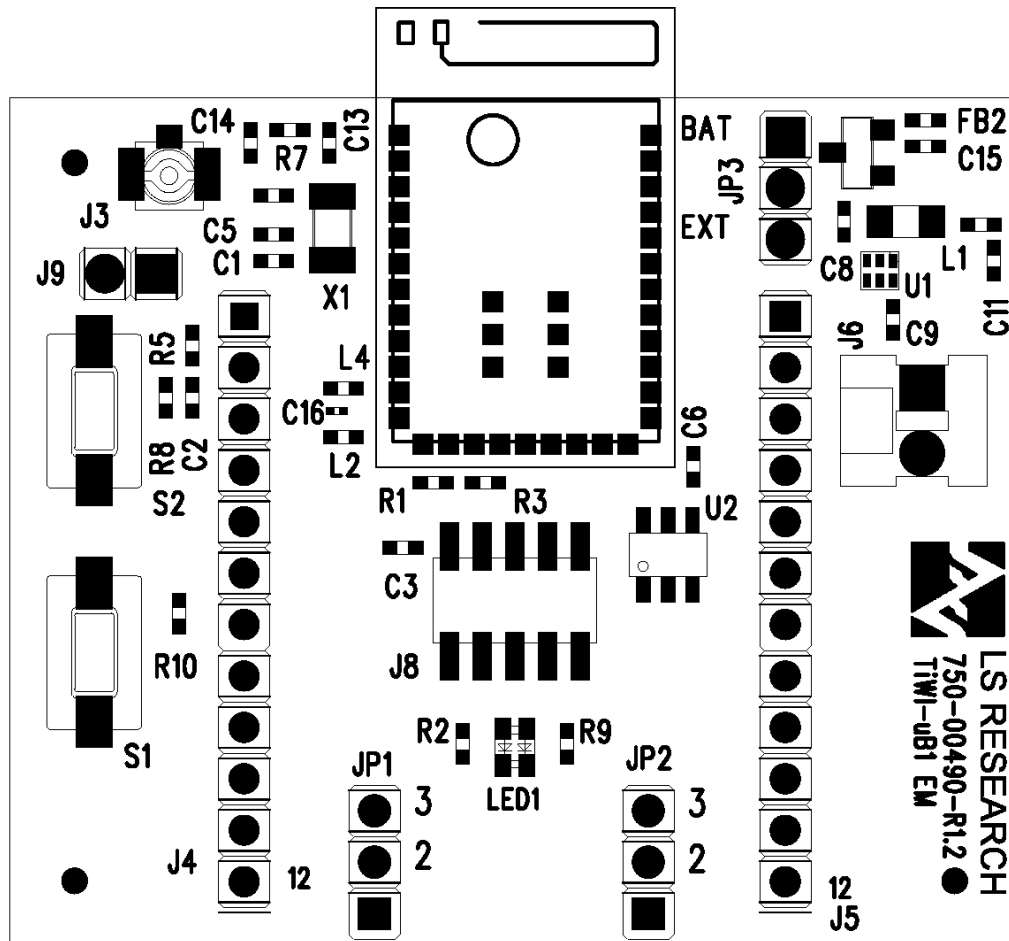

Figure 1 TiWi-uB1 EM Board Top Side

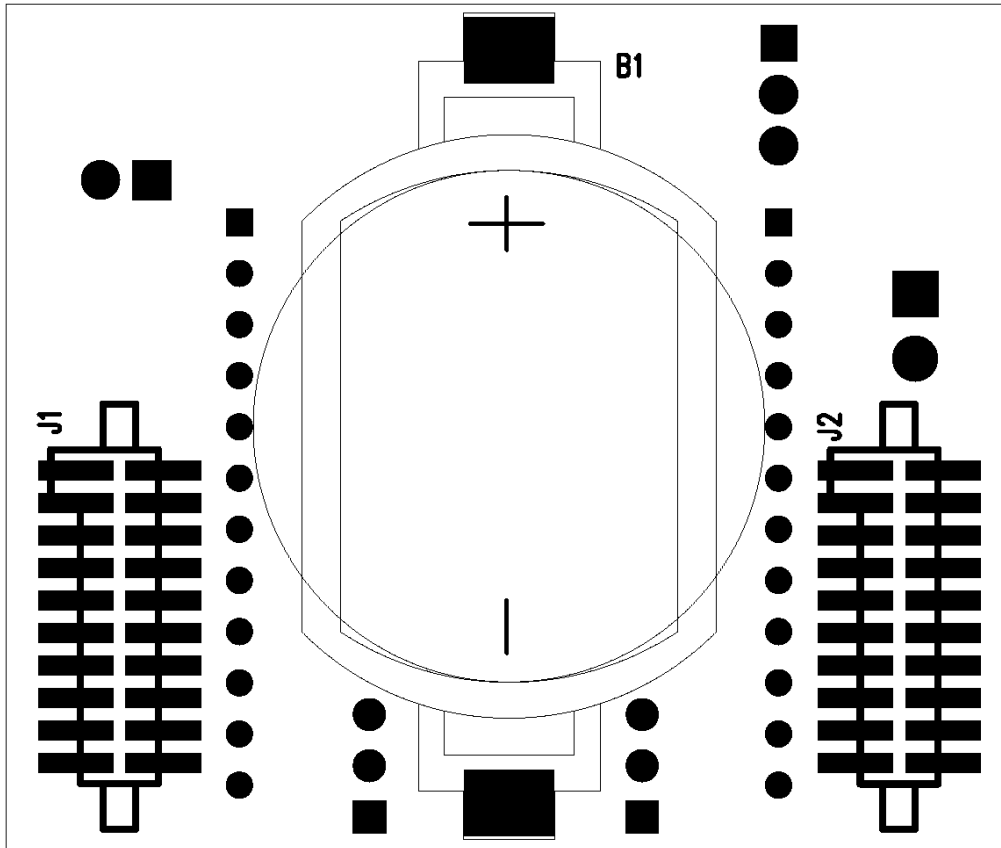

Figure 2 TiWi-uB1 EM Board Bottom

3 TiWi-uB1 EM Board Hardware

3.1 RF Connector

There are two TiWi-uB1 Module versions:

LSR Part Number	Description
450-0103	TiWi-uB1 Module, PCB Trace Antenna
450-0106	TiWi-uB1 Module, RF Castellation (Onboard Antenna Disabled)

Table 2 Module Part Numbers

The TiWi-uB1 EM board includes an on board U.FL RF connector J3 (Figure 1). When used in conjunction with TiWi-uB1 450-0106, J3 provides an RF connection point to external antennas or test equipment. When the TiWi-uB1 EM board is used with used with TiWi-uB1 450-0103, the U.FL connector has no electrical connection to the TiWi-uB1 450-0103.

The TiWi-uB1 is modular certified for FCC 15.247 and IC RSS-210, as well as compliant to the RF requirements for ETSI EN 300 328 and ETSI EN 301 489. The TiWi-uB1 450-0106 has modular certification when used with LSRs 001-0001 2.4 GHz Dipole Antenna with Reverse Polarity SMA Connector.

See the TiWi-uB1 datasheet and antenna user’s guide for further information regarding FCC/IC modular certification.

3.2 EM Interface Connectors

There are two primary connectors on the TiWi-uB1 EM Board, J1 & J2. These provide a standard interface to Texas Instruments development platforms. Refer to Table 3 and Table 4 below for details on the signals brought out to the EM connectors J1 and J2.

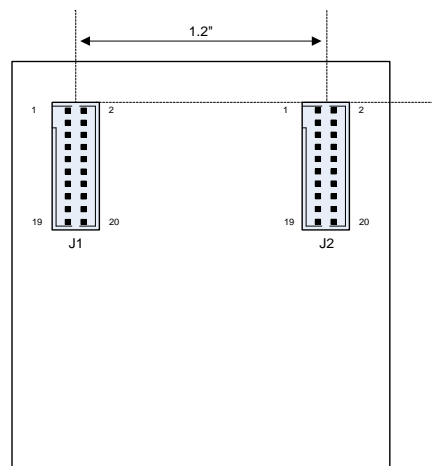

Figure 3 TiWi-uB1 EM Board Bottom



J1 Pin Number	Pin Name	Module Pin Type	Description
1	GND	Power	Ground
2	NC		Not Connected
3	P0.4	Digital I/O	Digital input/output
4	P1.3	Digital I/O	Digital input/output
5	P0.1	Digital I/O	Digital input/output
6	P1.0	Digital I/O	Digital input/output, 20mA output drive capable
7	P0.2	Digital I/O	Digital input/output
8	NC		Not Connected
9	P0.3	Digital I/O	Digital input/output
10	P2.1	Digital I/O	Debug Data or digital input/output
11	P0.0	Digital I/O	Digital input/output
12	P2.2	Digital I/O	Debug Clock or digital input/output
13	P1.1	Digital I/O	Digital input/output, 20mA output drive capable
14	P1.4	Digital I/O	Digital input/output
15	P0.6	Digital I/O	Digital input/output
16	P1.5	Digital I/O	Digital input/output
17	P0.7	Digital I/O	Digital input/output
18	P1.6	Digital I/O	Digital input/output
19	GND	Power	Ground
20	P1.7	Digital I/O	Digital input/output

Table 3 EM Connector J1



J2 Pin Number	Pin Name	Module Pin Type	Description
1	NC		Not Connected
2	GND	Power	Ground
3	NC		Not Connected
4	NC		Not Connected
5	NC		Not Connected
6	NC		Not Connected
7	VIN	Power	Power supply input (2.0v to 3.6v)
8	NC		Not Connected
9	VIN	Power	Power supply input (2.0v to 3.6v)
10	NC		Not Connected
11	NC		Not Connected
12	SCL	Digital I/O	I2C clock or digital input/output
13	NC		
14	SDA	Digital I/O	I2C data or digital input/output
15	/RESET	Digital Input	Active low reset to module
16	NC		Not Connected
17	P1.2	Digital I/O	Digital input/output
18	P0.5	Digital I/O	Digital input/output
19	P2.0	Digital I/O	Digital input/output
20	NC		Not Connected

Table 4 EM Connector J2



3.3 General Purpose Connectors

3.3.1 J6 Power Supply Input

J6 Pin Number	Pin Name	Module Pin Type	Description
1	VIN	Power	Power supply input (2.0v to 3.6v)
2	GND	Power	Ground

Table 5 Power Connector J6

3.3.2 J4 & J5 External Interface Headers

J4 Pin Number	Pin Name	Module Pin Type	Description
1	/RESET	Digital Input	Active low reset to module
2	P2.2	Digital I/O	Debug Clock or digital input/output
3	P2.1	Digital I/O	Debug Data or digital input/output
4	P2.0	Digital I/O	Digital input/output
5	SCL	Digital I/O	I2C clock
6	SDA	Digital I/O	I2C data
7	P1.7	Digital I/O	Digital input/output
8	P1.6	Digital I/O	Digital input/output
9	P1.5	Digital I/O	Digital input/output
10	P1.4	Digital I/O	Digital input/output
11	P1.3	Digital I/O	Digital input/output
12	GND	Power	Ground

Table 6 Single Row Header J4

J5 Pin Number	Pin Name	Module Pin Type	Description
1	P0.7	Digital I/O	Digital input/output
2	P1.0	Digital I/O	Digital input/output, 20mA output drive capable
3	P1.1	Digital I/O	Digital input/output, 20mA output drive capable
4	P0.6	Digital I/O	Digital input/output
5	P0.5	Digital I/O	Digital input/output
6	VIN	Power Input	Power supply input (2.0v to 3.6v)
7	P0.4	Digital I/O	Digital input/output
8	P0.3	Digital I/O	Digital input/output
9	P0.2	Digital I/O	Digital input/output
10	P0.1	Digital I/O	Digital input/output
11	P0.0	Digital I/O	Digital input/output
12	P1.2	Digital I/O	Digital input/output

Table 7 Single Row Header J5

The information in this document is subject to change without notice.



3.3.3 J9 External 32kHz Clock Input

J9 Pin Number	Pin Name	Module Pin Type	Description
1	CLK_IN ¹	Digital Input	Clock Input
2	GND	Power	Ground

1. Coupling capacitor C1 must be populated to use the external 32kHz clock input.

Table 8 External 32kHz Header J9

3.3.4 J8 Programming Header

J8 is the Texas Instruments CC Debugger interface to the TiWi-uB1 Module. The debug interface implements a proprietary two-wire serial interface that is used for in-circuit debugging and programming.

J8 Pin Number	Pin Name	Module Pin Type	Description
1	GND	Power	Ground
2	VIN	Power	Power Input
3	DBG_CLK	Digital Input	Debug Clock
4	DBG_DAT	Digital I/O	Debug Data
5	NC		Not Connected
6	NC		Not Connected
7	/RESET	Digital Input	Active low reset to module
8	NC		Not Connected
9	NC		Not Connected
10	NC		Not Connected

Table 9 Programming/Debug Header J8

3.4 Power Configuration Jumpers

Jumpers JP1, JP2, and JP3 are used to select the various modes of powering the TiWi-uB1 EM board.

- JP1 and JP2 are used for test purposes only and should remain in positions 2-3.
- JP3 is used to select either battery power or external power.

A TI TPS62730 (U1), 2.1V DC to DC converter is supplied, which when used with the TiWi-uB1 module, enables reduced peak and average current consumption up to 30% or more during radio transmit or receive modes. This is especially important in battery-powered applications by reducing current consumption while maintaining superior RF performance. See [Current Savings Using TPS62530](#) for more info.

1. Voltage on any digital pin to the TiWi-uB1 shall not exceed $\text{Max DVCC} + 0.3\text{V} \leq 3.9\text{V}$ or $\text{Min} -0.3\text{V}$.
2. When the TPS62730 bypass pin is asserted low, the TPS62730 is bypassed and $\text{AVCC/DVCC} = \text{VIN}$

Caution: Care must be taken when interfacing a battery powered TiWi-uB1 module to an externally powered Host or other external input. If the host is providing input to the module at 3.0V while the module is powered at 2.1V, the external input to the module will exceed DVCC + 0.3V requirement for the I/O and the TiWi-uB1 module will be damaged.

3.5 LED Indicators

There are 2 LEDs on the TiWi-uB1 EM board:

- LED1A - User Defined (connected to digital input/output P1.0, 20mA capable)
- LED1B - User Defined (connected to digital input/output P1.1, 20mA capable)

3.6 Push Button Switches

There are two push button switches on the TiWi-uB1 EM board:

- S1 - User defined switch
- S2 - Manual reset to the module



3.7 Connecting EM Board to Host Platform

The TiWi-uB1 can be operated in one of two different modes, determined by the firmware programmed into the module:

Stand Alone Mode - This is the most common configuration when using the TiWi-uB1 Module. In this mode, the controller, host, profiles, and application are all implemented on the TiWi-uB1 module as a true stand alone Bluetooth BLE solution. No interface to a host is required.

Network Processor Mode - The controller and host are implemented together on the TiWi-uB1 module, while the profiles and application are implemented separately. The application and profiles communicate with the TiWi-uB1 module by means of HCI commands using a SPI or UART interface. This configuration is useful for applications which execute on either another device (such as an external microcontroller) or a PC. In these cases, the application can be developed externally while still running the BLE stack on the CC2540/41.

The TiWi-uB1EM board uses USART 0 as the default UART interface and USART 1 as the default SPI interface (Figure 4).

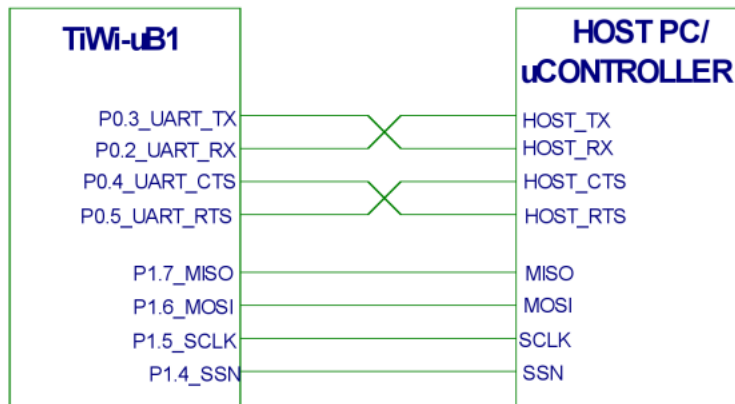

Figure 4 TiWi-uB1 EM Board Interface to Host

3.8 I²C Interface

The TiWi-uB1 EM board includes an I²C interface. The I²C provides an interface between the TiWi-uB1 module and the on board temperature sensor (U2), as well as other I²C compatible devices connected by the two-wire I²C serial bus. External components attached to the I²C bus serially transmit and/or receive serial data to/from the I²C on the TiWi-uB1 module through the two-wire I²C interface. The I²C bus supports any slave or master I²C -compatible device. Figure 5 shows an example of an I²C bus. Each I²C device is recognized by a unique address and can operate as either a transmitter or a receiver. A device connected to the I²C bus can be considered as the master or the slave when performing data transfers. A master initiates a data transfer and generates the clock signal, SCL. Any device addressed by a master is considered a slave. I²C data is communicated using the serial data (SDA) pin and the serial clock (SCL) pin.

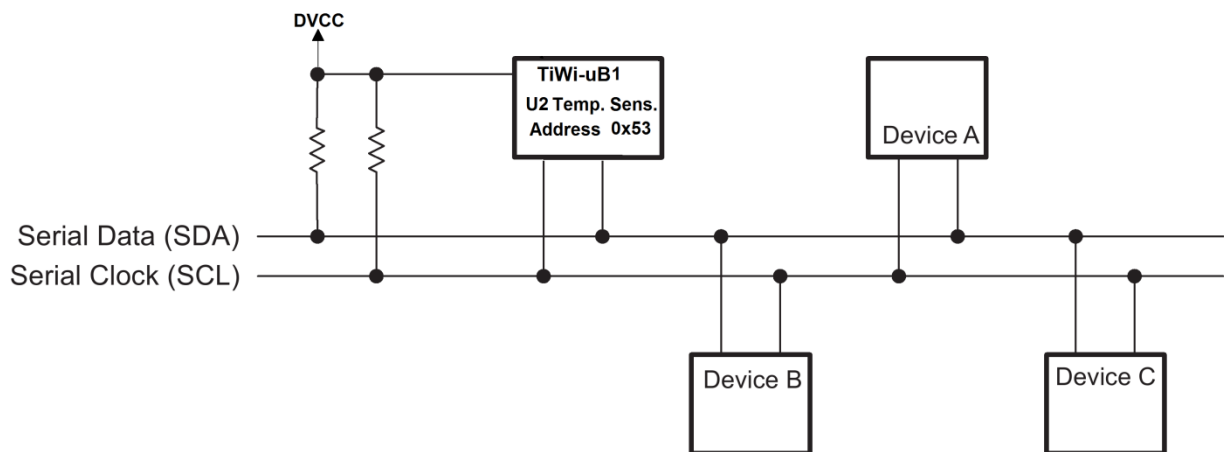

Figure 5 I²C Interface TiWi-uB1 EM Board Schematic

4 TiWi-uB1 EM Board Schematic

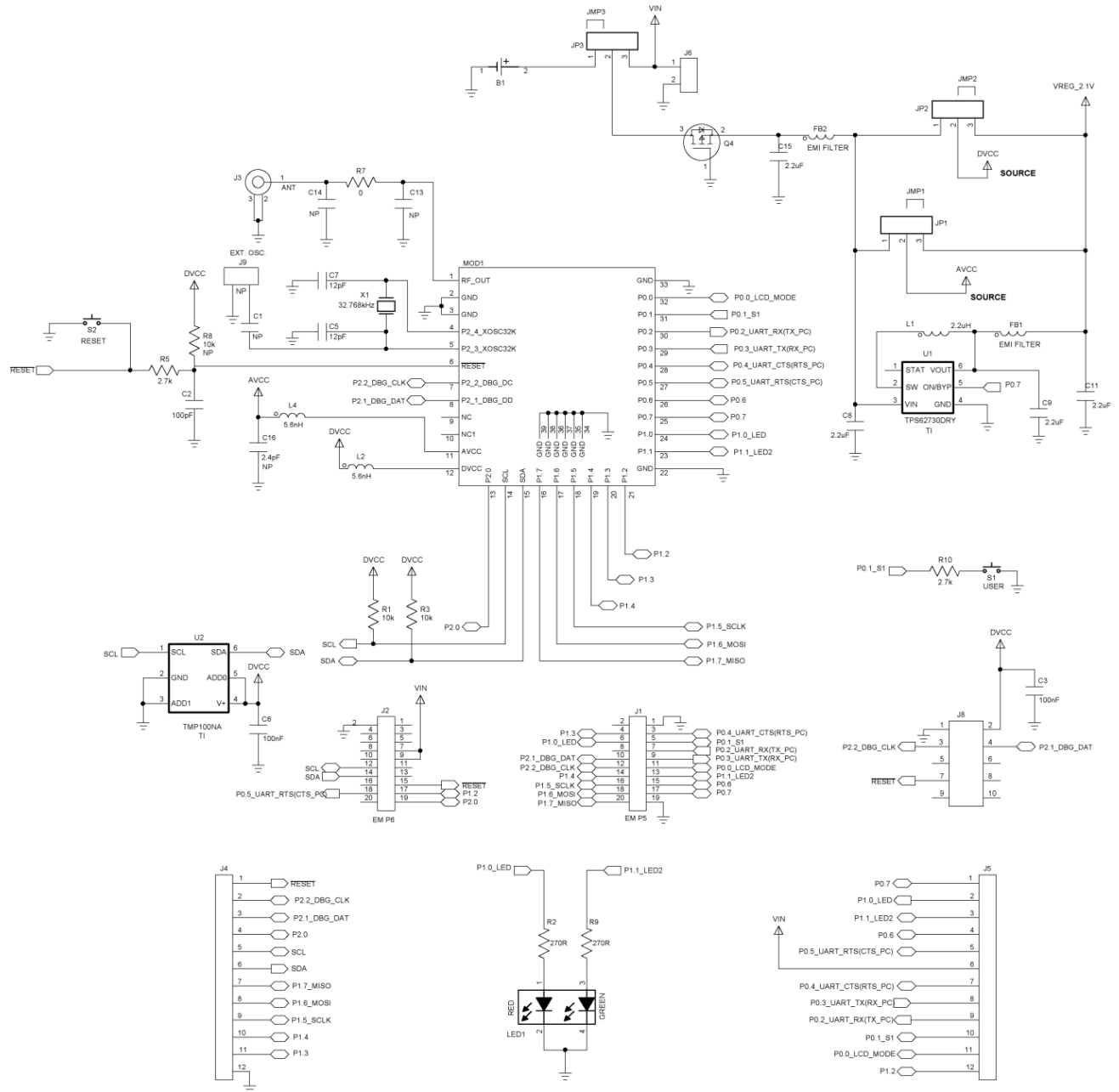

Figure 6 TiWi-uB1 EM Board Schematics

The information in this document is subject to change without notice.



4.1 Bill Of Material (BOM)

Reference	Pop Opt	Part Number	Description
B1		BU2032SM-G	Connector, Battery, Vertical SMT, 2032, NA, NA, 20mm battery
C1	NP	GRM155R71C104KA88#	Capacitor, MLCC, 16V, 0402, X7R, 100nF
C13 C14	NP		
C16	NP	250R05L2R4BV4T	Capacitor, MLCC, 25V, 0201, NPO, 2.4pF
C2		GRM1555C1H101JA01#	Capacitor, MLCC, 50V, 0402, COG, 100pF
C3 C6		GRM155R71C104KA88#	Capacitor, MLCC, 16V, 0402, X7R, 100nF
C5 C7		GRM1555C1H120JA01#	Capacitor, MLCC, 50V, 0402, COG, 12pF
C8 C9 C11 C15		C0402C225M9PAC#	Capacitor, MLCC, 6.3V, 0402, X5R, 2.2uF
FB1 FB2		BLM15HG102SN1#	Ferrite Bead, 0402, 1K Ohm @ 100MHz, 250mA
J1 J2		SFM-110-02-L-D-A	Connector, Header Female, Vertical SMT, Keyd, 2 x 10, 1.27mm, Gold Finish
J3		U.FL-R-SMT-1#	Connector, U.FL Jack, Vertical SMT, DC to 6 GHz, NA, NA, Gold Plated Contact
J4 J5		NRPN121PAEN-RC	Connector, Header Male, Vertical TH, Unshrouded, 1 x 12, 2mm, Gold Finish
J6		640456-2	Connector, Header Male, Vertical TH, Unshrouded, 1 x 2, 100mil, Tin Finish
J8		GRPB052VWQS-RC	Connector, Header Male, Vertical SMT, Unshrouded, 2 x 5, 50mil, Gold Finish
J9	NP	PRPN021PAEN-RC	Connector, Header Male, Vertical TH, Unshrouded, 1 x 2, 2mm, Gold Finish
JMP1 JMP2 JMP3		SPN02SXCN-RC	Connector, Shorting Jumper, Vertical TH, Black, 1 x 2, 2mm, Gold Finish
JP1 JP2 JP3		NRPN031PAEN-RC	Connector, Header Male, Vertical TH, Unshrouded, 1 x 3, 2mm, Gold Finish
L1		LQM21PN2R2NGC#	Inductor, Air Core Multilayer, 0805, 2.2uH
L2 L4		L-07C5N6SV6T	Inductor, Ceramic Core Multilayer, 0402, 5.6nH
LED1		APTB1612ESGC-F01	LED, Red/Green, 20mA, 2.0V, 12mcd, 0605, 625nm/568nm, Dual Color SMT
MOD1		450-0106C	TiWi-uB1 Module, RF Castellation, CT
Q4		FDN340P	PCB, TiWi-uB1 EM Board
R1 R3		RK73B1ET#103J	Transistor, MOSFET, P-CHANNEL, SOT-23-3
R2 R9		CRCW0402270RFK#	Resistor, Thick Film, 0402, 10K
R5 R10		CRCW04022K70FK#	Resistor, Thick Film, 0402, 270
R7		RK73Z1ET#	Resistor, Thick Film, 0402, 2.7K
R8	NP	RK73B1ET#103J	Resistor, Thick Film, 0402, 0
S1 S2		EVQ-PNF04M	Resistor, Thick Film, 0402, 10K
U1		TPS62730DRY#	Switch, Tactile, SPST-NO, 50mA @ 12V, SMT
U2		TMP100NA#	IC, Switching Voltage Regulator, SON, Step Down Converter with Bypass Mode
X1		ECS-.327-12.5-34B	IC, Temp Sensor, SOT-23-6, IIC

Table 10 TiWi-uB1 EM Board BOM



5 Application Development

5.1 Overview

The TiWi-uB1 EM Board has been designed to work either as a standalone development platform or to be used in combination with one of TI various development platforms. This flexible design platform allows the user to take advantage of the sample applications provided by LSR as well as those provided by TI for the CC2541 SOC.

LSR's Design Services team can be contracted to assist customers with application-specific software or hardware development for TiWi-uB1 applications.

For an overview of development platforms and software examples see [LSR Wireless Products](#) or [TI CC2541 Bluetooth](#).

5.2 Development Tools

5.2.1 LSR TiWi-uB1 EM Board Stand Alone Application

The LSR development kit demonstrates the stand alone capability of the TiWi-uB1 EM development board and connectivity to a Bluetooth® BLE enabled smartphone device. It provides a platform to show the capability of Bluetooth® BLE for simple remote control of devices and low data rate remote data collection and reporting.

LSRs TiWi-uB1 development kit hardware, sample firmware and iPhone Application allow the user to:

- Monitor temperature of the onboard temperature sensor U2
- Monitor battery voltage
- Monitor RSSI of data transmission from the TiWi-uB1 module to the iPhone
- Monitor the status of the onboard pushbutton switch S1
- Toggle the user defined LEDs 1A and 1B on and off
- Track RF statistics such as number of BLE packets sent and received

Hardware required for the LSR Standalone evaluation application includes:

- TiWi-uB1 EM Board with coin cell battery (Figure 7)
- Figure 7 TiWi-uB1 EM BoardTI CC Debugger (Figure 8)
- Bluetooth® 4.0 enabled iOS devices such as iPhone 4s or later, iPod Touch with LSR application running (Figure 9)



Figure 7 TiWi-uB1 EM Board

5.2.2 TI CC Debugger

The TI CC Debugger is used to program firmware into the TiWi-uB1 module. It can also be used along with IAR Embedded Workbench for 8051 to write and debug custom firmware for the TiWi-uB1 module. See [TI CC Debugger](#) for more information.



Figure 8 TI CC Debugger



5.2.3 TiWi-uB1 EM Board Firmware

The TiWi-uB1 EM Board firmware can be downloaded from the TiWi-uB1 Wiki in binary or source code form.

EM Board (BLE peripheral) Firmware Features

- At startup the TiWi-uB1 module will start advertising and continue to advertise for ≈ 30 seconds. During advertising the red LED will be on.
- Advertising can be turned on or off by pressing the USER (S1) button.
- Once connected to a Central Device, the red LED will turn off. The connection interval is set to 250ms.
- Once connected, the USER button can be held for ≥ 8 seconds (hold until the red LED turns on) to disconnect from the Central Device. After disconnecting the module will start advertising right away.
- Once connected, the user button can be held for ≥ 4 seconds (until the green LED turns on) but not longer than 8 seconds to enable the TPS62730 regulator during battery voltage readings. By default the battery voltage readings are done the TPS62730 in bypass mode so the actual battery voltage can be read.
- Four demo services are available in the firmware. Battery level, GPIO, range test, and temperature.

5.2.4 iOS Application

The sample LSR iOS application can be used on any Apple device running iOS 5 or later. It is intended to demonstrate the capabilities of the TiWi-uB1 and provides a starting point for users intending to write their own iOS applications. The LSR iOS demonstration application performs the following functions:

- Establishes a connection to any LSR TiWi-uB1 EM Board (Figure 10).
- Displays RSSI (Received Signal Strength) of the iOS device and the LSR TiWi-uB1 EM Board (Figure 11).
- Allows the user to remotely control the LSR TiWi-uB1 EM Board LEDs remotely (Figure 11).
- Graphically shows the status of the LSR TiWi-uB1 EM Board on board user switch (Figure 11).
- Displays the temperature from the temperature sensor on board the LSR TiWi-uB1 EM Board (Figure 11).
- Displays the Battery or supply voltage of the LSR TiWi-uB1 EM Board (Figure 11).
- Displays the RF statistics of the LSR TiWi-uB1 EM Board (Figure 12).



Using the Demo iOS Application

- Power up the TiWi-uB1 EM board using either a battery or an external power supply.
- Start the LSR iOS application (Figure 9).
- Touch the “Scan” button to scan for available TiWi-uB1 EM Boards. All available TiWi-uB1 devices within range will be displayed. (Figure 10).
- Select the LSR TiWi-uB1 device to connect to (Figure 10).
- Touch the “Connect to uB1 Module” button (Figure 10).
- Once a connection to TiWi-uB1 EM board has been established with the iOS device, the red LED on the TiWi-uB1 EM board will turn off and the “Control and Monitoring” screen will become visible (Figure 11).
- Slide the LED 1 and LED 2 slide switches to manually turn on and off the red and green LEDs on the TiWi-uB1 EM board.
- Momentarily press the user button on the TiWi-uB1 EM board and observe the Button Status display box change from Released to Pressed.
- Battery or Power supply voltage is displayed in the Voltage text box. Pressing the user button for ≈ 5 sec will illuminate the Green LED, enable the 2.1 V regulator and the Voltage text box should change to $\approx 2.1V$. Pressing the user button again for ≈ 5 Sec will disable the 2.1V regulator and the real battery voltage will be read. Battery voltage updates every 5 seconds.
- Touch the “RF Statistics” button at the bottom of the control and monitoring screen and the “RF Statistics” screen will become visible showing RF statistics of the Bluetooth link between the iOS device and the TiWi-uB1 EM board (Figure 11).

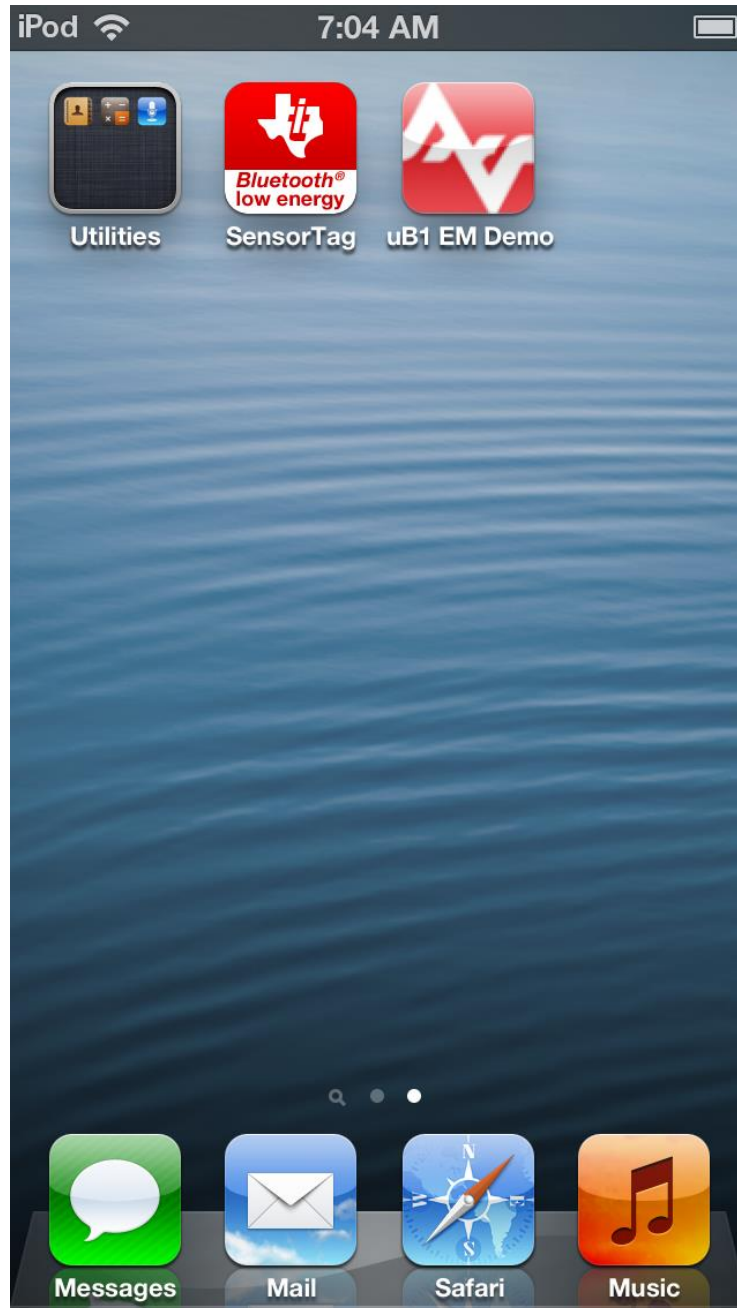

Figure 9 Sample LSR iPhone Application



2 Device(s) Found

-  **uB1 Module** ✓
RSSI: -64 dBm
-  **uB1 Module**
RSSI: -49 dBm

Scan **Connect to uB1 Module**

Figure 10 Sample LSR iOS Application – Screen 1

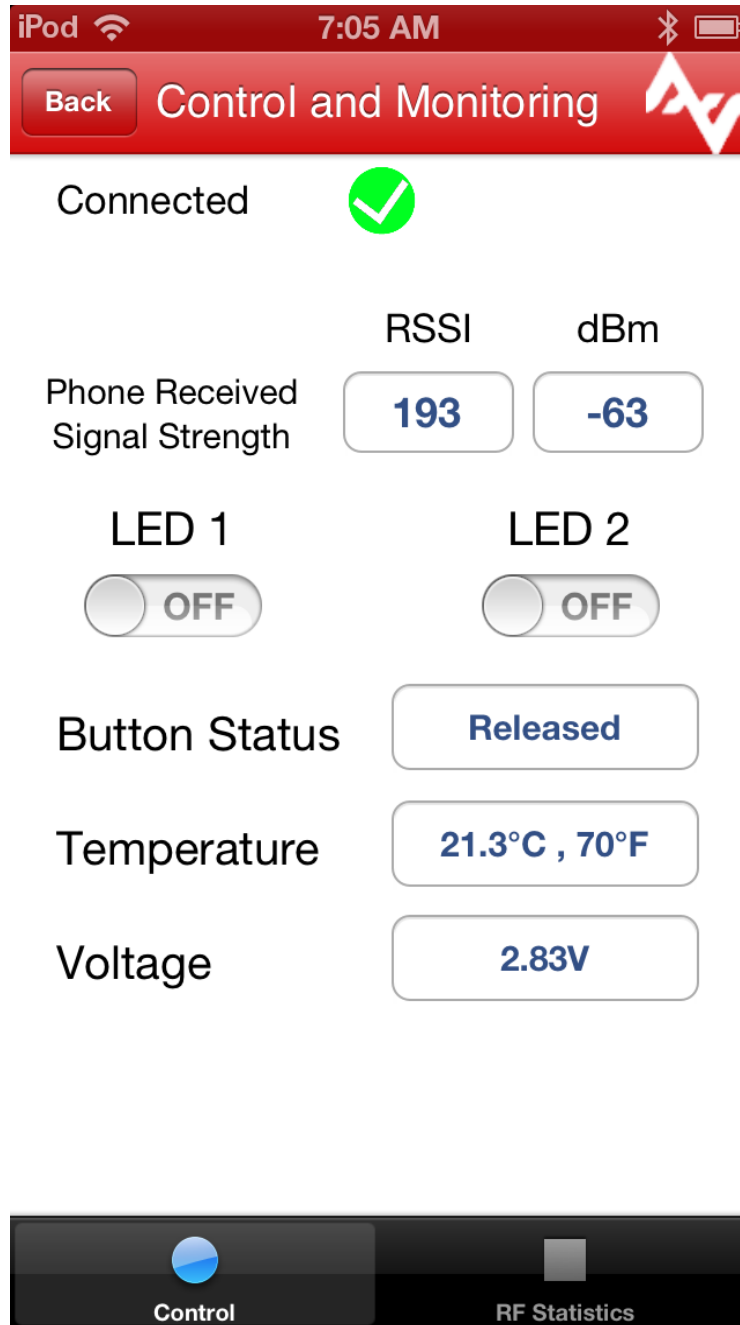

Figure 11 Sample LSR iOS Application – Screen 2

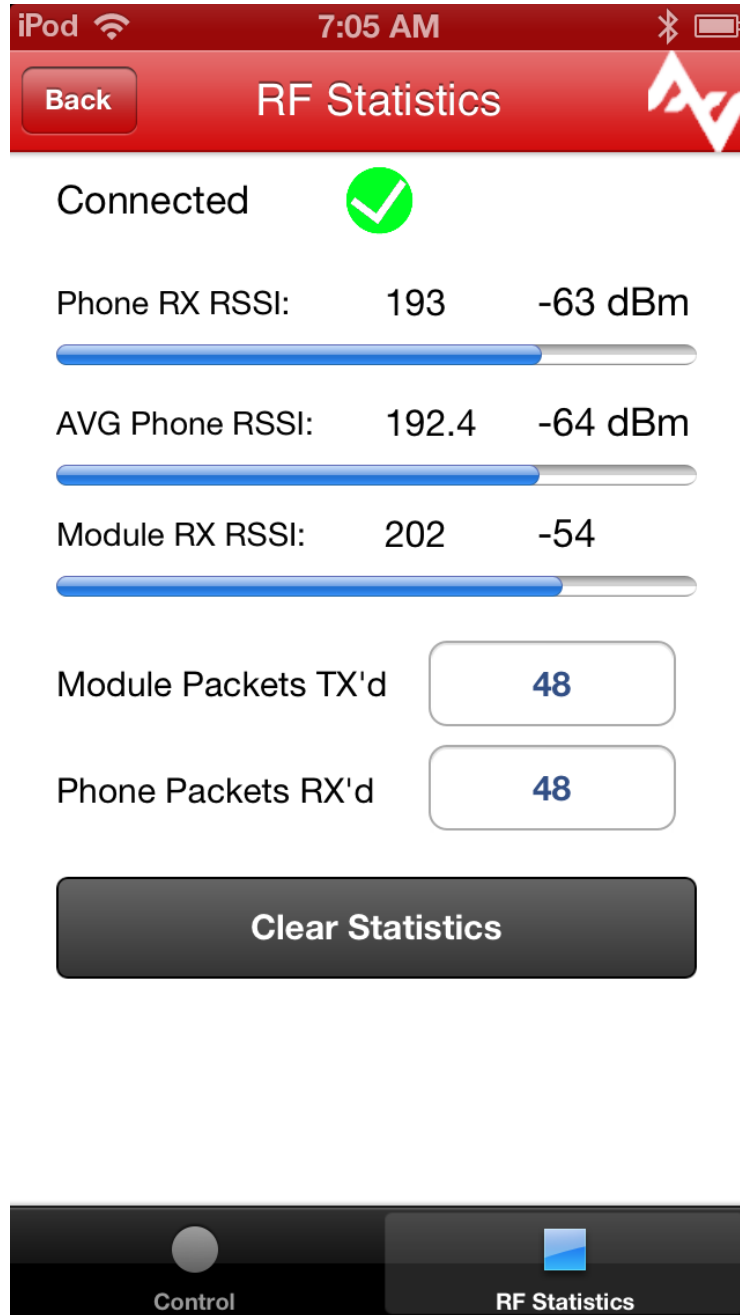

Figure 12 Sample LSR iOS Application – Screen 3



5.2.5 TI SmartRF05 EVB

The SmartRF05 Evaluation Board from TI can be used as a motherboard for the TiWi-uB1 EM board.

The board has a wide range of user interfaces, such as:

- 3x16 character serial LCD
- Full speed USB 2.0 interface
- UART
- LEDs
- Serial Flash
- Potentiometer
- Joystick
- Buttons
- Breakout pins

The SmartRF05 Evaluation can connect to a PC via USB to control the TiWi-uB1 module and the SmartRF05 Evaluation Board. It can also be used in place of the CC Debugger to program firmware into the TiWi-uB1 module. See [TI SmartRF05 Evaluation Board](#) for more info on the SmartRF05 Evaluation Board.

Hardware required for TI SmartRF05 Dev Kit includes:

- TiWi-uB1 EM Board (Figure 7)
- TI SmartRF05 EVB (**Error! Reference source not found.**)

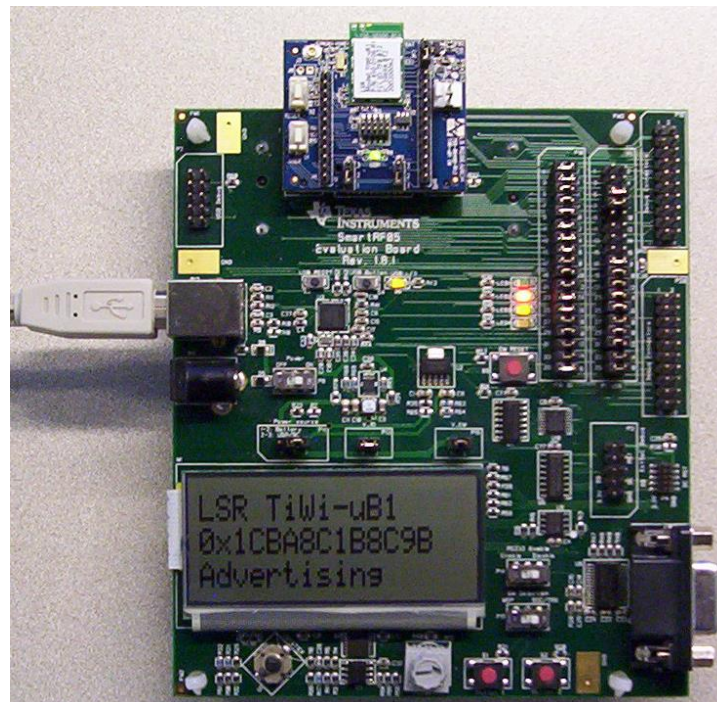

Figure 13 TI SmartRF05 EVB with LSR TiWi-uB1 EM Board



5.3 Software Development

Software development for the TiWi-uB1 requires IAR Embedded Workbench for 8051. See [IAR Embedded Workbench](#) for more information.

Follow the links below for TiWi-uB1 software development tools and sample applications.

- [CC 2541 Software Examples](#)
- [TI BLE Software Stack and Sample Apps](#)
- [BLE iOS Example App](#)



6 Contacting LS Research

Headquarters	LS Research, LLC W66 N220 Commerce Court Cedarburg, WI 53012-2636 USA Tel: 1(262) 375-4400 Fax: 1(262) 375-4248
Website	www.lsr.com
Wiki	www.lsr.com/products-wiki
Technical Support	www.lsr.com/products-forum
Sales Contact	sales@lsr.com

The information in this document is provided in connection with LS Research (hereafter referred to as “LSR”) products. No license, express or implied, by estoppel or otherwise, to any intellectual property right is granted by this document or in connection with the sale of LSR products. EXCEPT AS SET FORTH IN LSR’S TERMS AND CONDITIONS OF SALE LOCATED ON LSR’S WEB SITE, LSR ASSUMES NO LIABILITY WHATSOEVER AND DISCLAIMS ANY EXPRESS, IMPLIED OR STATUTORY WARRANTY RELATING TO ITS PRODUCTS INCLUDING, BUT NOT LIMITED TO, THE IMPLIED WARRANTY OF MERCHANTABILITY, FITNESS FOR A PARTICULAR PURPOSE, OR NON-INFRINGEMENT. IN NO EVENT SHALL LSR BE LIABLE FOR ANY DIRECT, INDIRECT, CONSEQUENTIAL, PUNITIVE, SPECIAL OR INCIDENTAL DAMAGES (INCLUDING, WITHOUT LIMITATION, DAMAGES FOR LOSS OF PROFITS, BUSINESS INTERRUPTION, OR LOSS OF INFORMATION) ARISING OUT OF THE USE OR INABILITY TO USE THIS DOCUMENT, EVEN IF LSR HAS BEEN ADVISED OF THE POSSIBILITY OF SUCH DAMAGES. LSR makes no representations or warranties with respect to the accuracy or completeness of the contents of this document and reserves the right to make changes to specifications and product descriptions at any time without notice. LSR does not make any commitment to update the information contained herein. Unless specifically provided otherwise, LSR products are not suitable for, and shall not be used in, automotive applications. LSR’s products are not intended, authorized, or warranted for use as components in applications intended to support or sustain life.