

# D2E133 Series Centrifugal Blower

Ø 133mm



- AC dual inlet, forward curved centrifugal blower. Via a bracket, the integrated external-rotor motor is mounted on one side of the housing.

- Housing and impeller made of galvanized sheet-steel. Forward curved impellers are directly press-fitted onto the rotor of the external-rotor motor.

- Direction of rotation is CW as seen from inlet opposite the cable exit. Insulation class "B".

- Maintenance-free ball bearings.

- UL, CSA, VDE approvals on most models, please contact application engineering.

Part Number	Curve	CFM @ 0	VAC	Hertz	Power (W)	dBA	Max Amb. Temp C	Bearing Type	Features	Capacitor (µF)	Wgt. (lbs)
D2E133-BI40-50	1	180	230	60*	110	49	50	Ball	Leads	2	6.50
D2E133-AM47-A7	2	300	230	60*	200	56	40	Ball	Leads	3	7.71
D2E133-DM47-01	3	353	230	60*	195	55	40	Ball	Leads	3	9.70
D2E133-DM47-23	3	353	230	60*	195	55	40	Ball	Leads	3	9.70
D2E133-DM47-A3	3	353	230	60*	195	55	40	Ball	Leads	3	9.70
D2E133-DM67-78	4	420	115	60	205	55	40	Ball	Leads	12	9.00

\* 50 Hz data available.

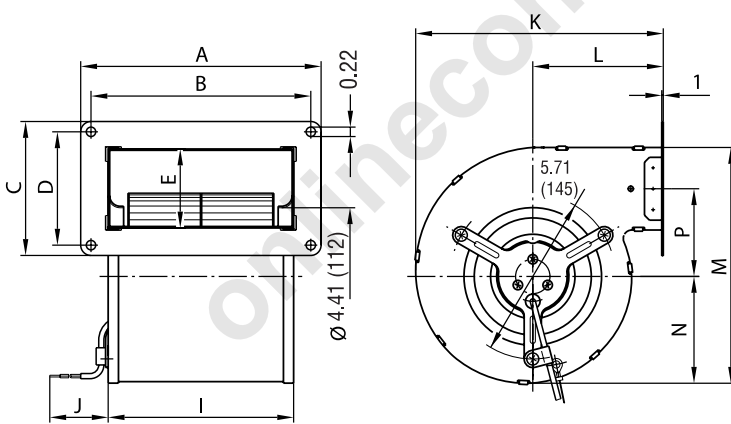

Type	A	B	C	D	E	I	J	K	L	M	N	P
D2E 133-BI	194 (7.64)	178 (7.01)	108 (4.25)	92 (3.62)	69 (2.72)	155 (6.10)	300 (11.8)	171.5 (6.75)	88 (3.46)	180 (7.09)	79 (3.11)	66.0 (2.60)
D2E 133-AM	254 (10.0)	238 (9.37)	108 (4.25)	92 (3.62)	69 (2.72)	215 (8.46)	300 (11.8)	171.5 (6.75)	88 (3.46)	180 (7.09)	79 (3.11)	66.0 (2.60)
D2E 133-DM	270 (10.6)	254 (10.0)	142 (5.59)	126 (4.96)	102 (4.02)	232 (9.13)	300 (11.8)	204.0 (8.03)	97 (3.82)	213 (8.39)	98 (3.86)	67.5 (2.66)

