



Agilent 87300B,C,D and 87301B,C,D,E Directional Couplers

87310B Hybrid Coupler

Technical Overview

Features and Description

- Compact size
- Broadband up to 50 GHz
- Excellent performance

The Agilent Technologies 87300 series of compact, broadband directional/sampling and hybrid couplers are well suited for signal monitoring or, when combined with a coaxial detector, signal leveling. See page 2 for the wide range of product offerings.



Figure 1.

Product Applications

These compact, broadband directional couplers are important components for many microwave measurement systems. Although most modern signal generators and sweepers supply signals whose power levels are stable with respect to frequency, variations in signal level are introduced due to the cable losses (which increase with frequency) and the frequency response of other components in the signal path. Inserting a directional coupler into the system with a suitable microwave detector to supply feedback to the ALC circuit of a signal generator or sweeper provides a leveled signal at a particular point in the system (Figure 8).

Agilent 8474B,C,E detectors offer excellent broad-band frequency response and low SWR for this application. Other applications include power monitoring with an 848X series power sensor connected to the sampling port. Connect the sampled signal port to a microwave counter to monitor frequency or to a signal analyzer for frequency spectrum monitoring (Figure 9).

(See Figures 8 and 9 on page 4.)



Specifications

Model	87300B	87300C	87300D
Frequency range (GHz)	1 to 20 GHz	1 to 26.5 GHz	6 to 26.5 GHz
Nominal coupling and variation with respect to output (or coupling factor over insertion loss)	10 ± 0.5 dB	10 ± 1 dB	10 ± 0.5 dB
Frequency sensitivity	± 0.35 dB, 1 to 20 GHz	± 0.5 dB, 1 to 26.5 GHz	± 0.3 dB
Directivity	> 16 dB	> 14 dB, 1 to 12.4 GHz > 12 dB, 12.4 to 26.5 GHz	> 13 dB
Maximum SWR	1.35	1.35, 1 to 12.4 GHz 1.50, 12.4 to 26.5 GHz	1.40
Insertion loss	< 1.5 dB	< 1.2 dB, 1 to 12.4 GHz < 1.7 dB, 12.4 to 26.5 GHz	< 1.3 dB
Typical insertion loss (dB, f = freq. in GHz)	0.6 + 0.04f	0.6 + 0.04f	0.6 + 0.025f
Power rating Average Peak	20 W 3 kW	20 W 3 kW	20 W 3 kW
Connectors	SMA (f)	3.5 mm (f)	3.5 mm (f)
Weight in grams (oz)	74 (2.6)	60 (2.1)	31.2 (1.1)

Model	87301B	87301C	87301D	87301E
Frequency range (GHz)	10 to 46 GHz	10 to 50 GHz	1 to 40 GHz	2 to 50 GHz
Nominal coupling and variation with respect to output (or coupling factor over insertion loss)	10 ± 0.7 dB	10 ± 0.7 dB	13 ± 1 dB	10 ± 1 dB
Frequency sensitivity	± 0.3 dB	± 0.5 dB	± 1.2 dB, 1 to 40 GHz	± 0.6 dB, 2 to 26.5 GHz ± 0.8 dB, 2 to 50 GHz
Directivity	> 10 dB	> 10 dB	> 14 dB, 1 to 20 GHz > 10 dB, 20 to 40 GHz	> 13 dB, 2 to 26.5 GHz > 10 dB, 26.5 to 50 GHz
Maximum SWR	1.80	1.80	1.5, 1 to 20 GHz 1.7, 20 to 40 GHz	1.5, 2 to 26.5 GHz 1.8, 26.5 to 50 GHz
Insertion loss	< 1.9 dB	< 1.9 dB	< 1.2 dB, 1 to 20 GHz < 1.9 dB, 20 to 40 GHz	< 2 dB
Typical insertion loss	0.8 + 0.022f	0.8 + 0.022f	0.4 + 0.035f	0.55 + 0.025f
Power rating Average Peak	20 W 3 kW	20 W 3 kW	20 W 3 kW	20 W 3 kW
Connectors	2.92 mm (f)	2.4 mm (f)	2.4 mm (f) or 2.92 mm (f) for Option 292	2.4 mm (f)
Weight in grams (oz)	28.4 (1)	28.4 (1)	37 (1.3)	34 (1.2)

Agilent 87310B Specifications

Frequency range	1 to 18 GHz
Coupling	3 dB
Amplitude imbalance	± 0.5 dB at each port, centered at -3 dB
Phase imbalance	± 10 degrees
Isolation	> 17 dB
Maximum SWR	1.35
Insertion loss	< 2 dB
Power rating	
Average	20 W
Peak	3 kW
Connectors	SMA (f)
Weight in grams (oz)	148 (5.2)

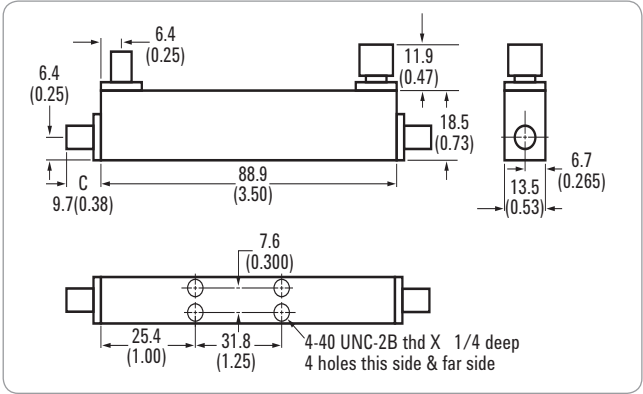

Figure 2. 87300B

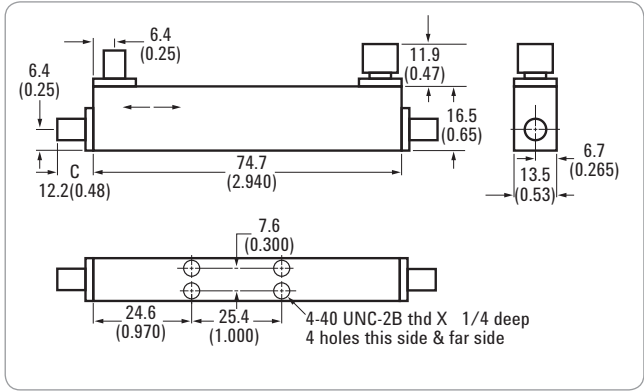

Figure 3. 87300C

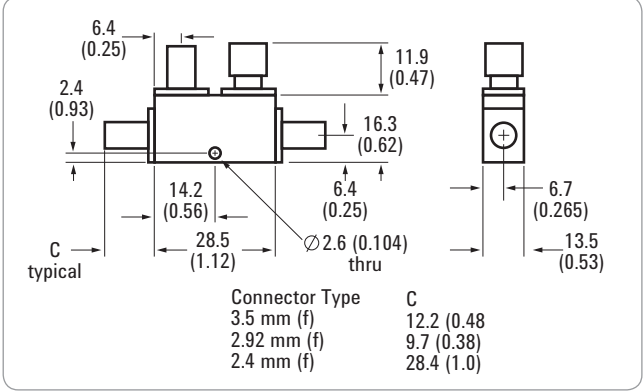

Figure 4. 87300D

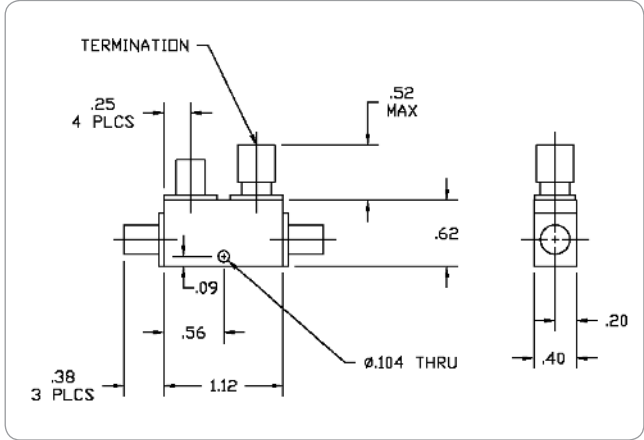

Figure 5. 87301B, 87301C

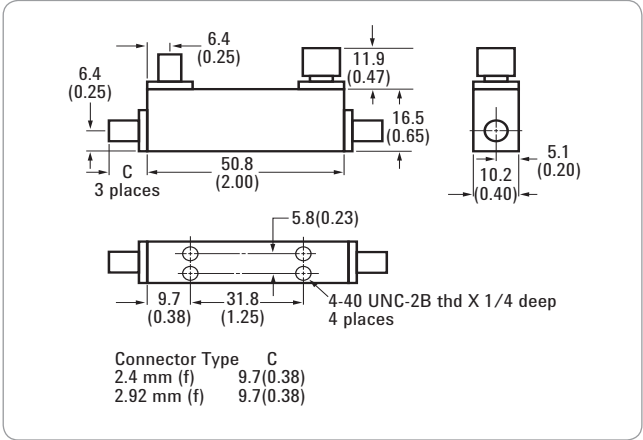

Figure 6. 87301D, 87301E

1. Dimensions are in millimeters (inches) nominal unless otherwise specified.

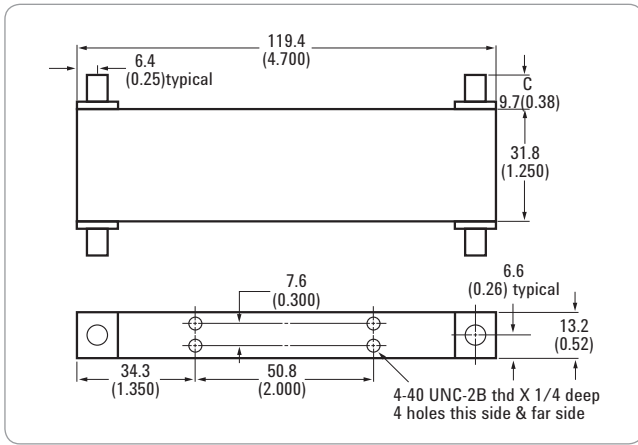

Figure 7. 87310B

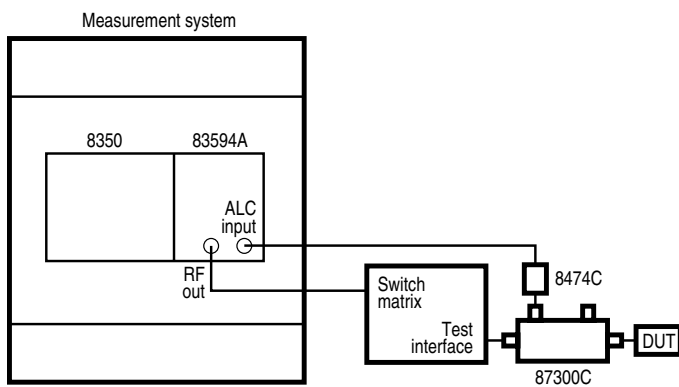

Figure 8.

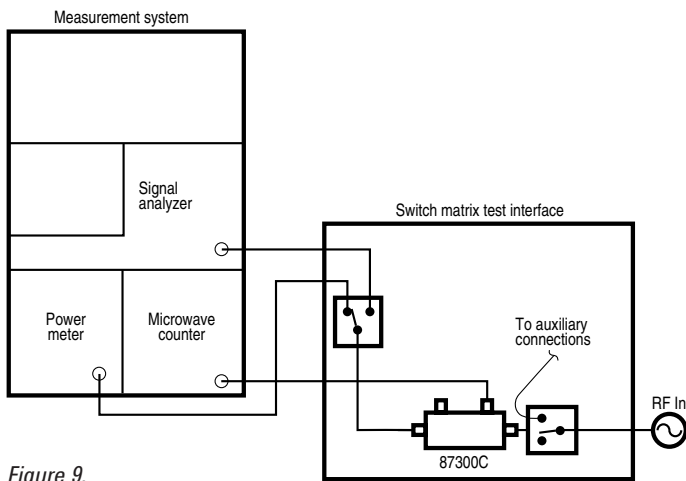

Figure 9.

1. Dimensions are in millimeters (inches) nominal unless otherwise specified

Quick Check Procedure

Throughout this procedure, each connection made must be accomplished by following the *Principles of Microwave Connector Care*. Select the correct microwave cables and adapters when preparing the test setup.

Agilent 87300B/C/D and 87301B/C/D/E Directional Coupler

1. Calibrate the network analyzer with full 2-Port calibration with setup based on network analyzer model being used. The test setup is shown in Figure 10.

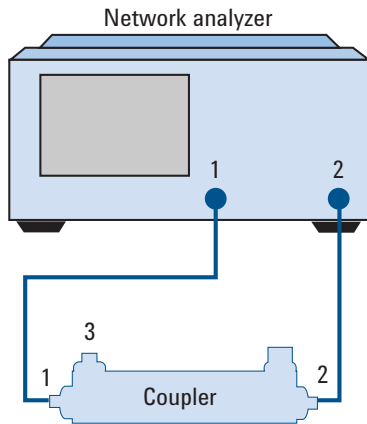

Figure 10. Equipment setup using network analyzer with coupler

2. Save Cal Set to network analyzer's memory.
3. Connect the device under test (DUT) to the network analyzer per Figure 10. **The unused port to be terminated with a 50 Ω termination.**
4. Measure insertion loss (S21). Measure input port and output port VSWR and record only worst case measurement on either port (S11) or (S22), and verify the measurement is within the limits as shown in the specification. **Normalize S21¹.**

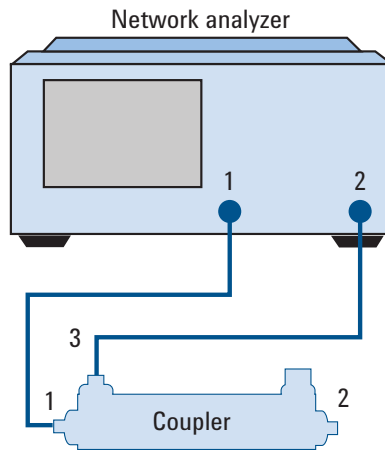

Figure 11. Equipment setup using network analyzer with coupler port 1 and port 3

5. Move test port 2 to port 3 of DUT, see Figure 11. **The unused port to be terminated with a 50 Ω termination.** Measure and record coupled port VSWR (S33) and verify the measurement is within the limits as shown in the specification.
6. Measure **nominal coupling (S31/S21)²** and **frequency sensitivity (S31/S21)²** by using the equations below.

7. With the same setup as Figure 11, **normalize S31¹.**
8. Reverse the coupler as shown in Figure 12. Measure and record **directivity (S32/S31)².**

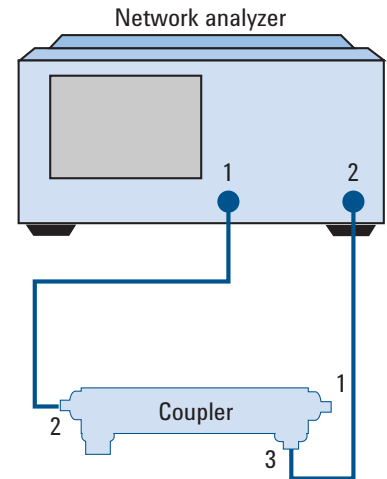

Figure 12. Equipment setup using network analyzer with coupler port 2 and port 3

$$\text{Nominal coupling}^3 = \frac{\text{min. coupling point} + \text{max. coupling point}}{2}$$

$$\text{Frequency sensitivity}^3 = \frac{\text{min. coupling point} - \text{max. coupling point}}{2}$$

1. Store the S-parameter trace in network analyzer's memory.
2. Perform "Data / Mem" operation (current measurement data is divided by the data in memory). Then under trace view options, select "data trace" to display the actual measurement trace.
3. From the current measurement trace (after Data / Mem function performed), turn on Marker 1 and 2, then locate the minimum and maximum coupling points respectively. Calculate the "nominal coupling" or "frequency sensitivity" using the given formulas above.

Agilent 87310B Hybrid Coupler

1. Select the correct microwave cables and adapters when preparing the test setup.
2. Calibrate the network analyzer with full 2-port calibration with setup based on network analyzer model being used. The test setup is shown in Figure 13.
3. Save Cal Set to network analyzer's memory.
4. Connect the device under test (DUT) to the network analyzer per Figure 13. The unused port to be terminated with a 50 Ω termination.
5. Measure the maximum input and 0 degree output port VSWR and record only worst case measurement on either port, (S11) or (S22). Maximum specified VSWR is 1.35. Then **normalize S21**⁴.
6. Move test port 2 to port 3 of the DUT, see Figure 14. The unused port to be terminated with a 50 Ω termination. Measure and record -90 degree output port 3 VSWR (S33). Verify the measurement is within the limits as shown in the specification.

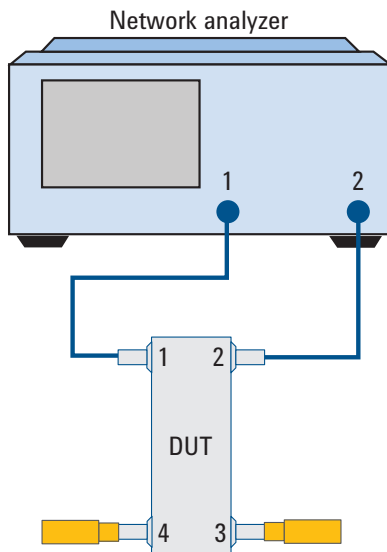

Figure 13. Equipment setup using network analyzer with coupler

4. Store the S-parameter trace in the network analyzer's memory.
5. Perform "Data / Mem" operation (current measurement data is divided by the data in memory). Then under trace view options, select "data trace" to display the actual measurement trace.
6. The maximum amplitude imbalance at any specific frequency point is 1.0 dB as referenced at 0.0 dB within the frequency band.

7. Measure **amplitude imbalance (S31/S21)**⁵.

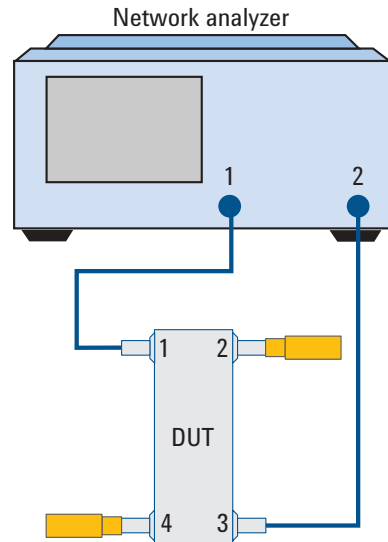

Figure 14. Equipment setup using network analyzer with coupler port 1 and port 3

The following example (Figure 15), of the maximum deviation from 0.0 dB reference is approximately -0.7 dB at 1 GHz. The allowable maximum imbalance is 1.0 dB⁶. So the measured amplitude imbalance value -0.7 dB is within the specification.

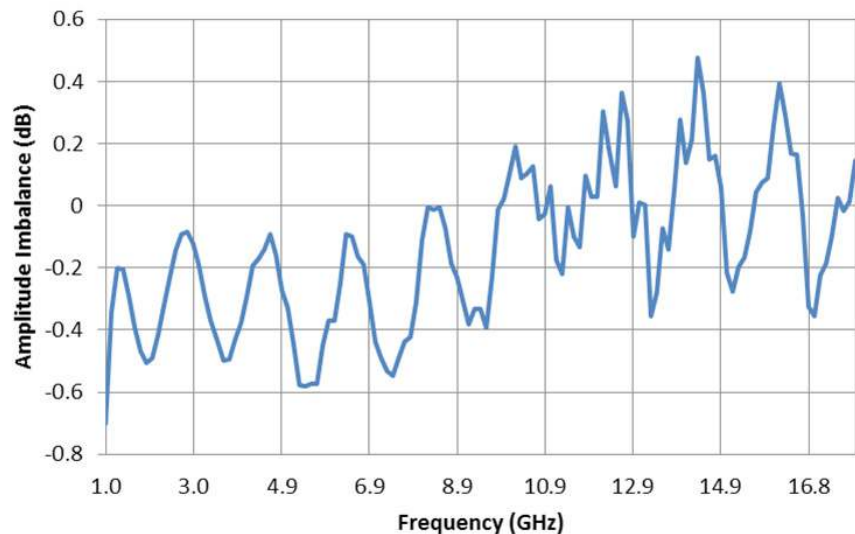

Figure 15. This graph shows the maximum deviation from 0.0 dB reference is approximately -0.7 dB at 1 GHz. The allowable maximum imbalance is 1.0 dB⁶. So the measured amplitude imbalance value -0.7 dB is within the specification.

8. With the same setup as above, change the format to phase and measure the **phase imbalance (S31/S21)**⁷.

9. Connect the DUT as shown in Figure 16. Measure and record **isolation S41 and S44 SWR**.

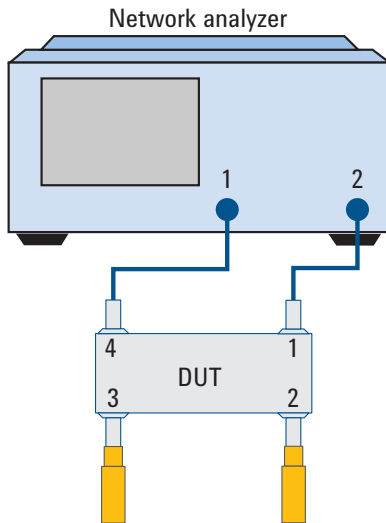

Figure 16. Equipment setup using network analyzer with coupler port 1 and port 4

10. Connect the DUT as shown in Figure 17. Measure and record **isolation S32**.

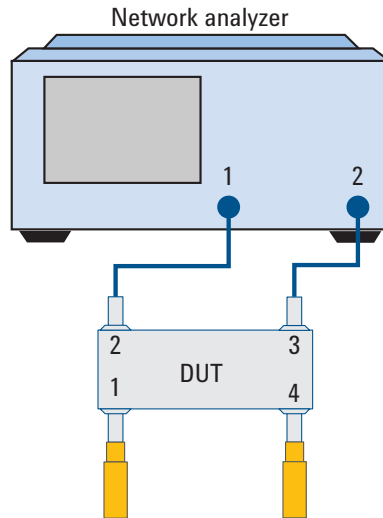

Figure 17. Equipment setup using network analyzer with coupler port 1 and port 3

7. Phase imbalance is defined as the difference between phases of port 3 to port 2 within the frequency band.



myAgilent

www.agilent.com/find/myagilent

A personalized view into the information most relevant to you.



Agilent Advantage Services

www.agilent.com/find/AdvantageServices

Accurate measurements throughout the life of your instruments.

Agilent Channel Partners

www.agilent.com/find/channelpartners

Get the best of both worlds: Agilent's measurement expertise and product breadth, combined with channel partner convenience.



www.agilent.com/quality

www.agilent.com
www.agilent.com/find/mta

For more information on Agilent Technologies' products, applications or services, please contact your local Agilent office. The complete list is available at: www.agilent.com/find/contactus

Americas

Canada	(877) 894 4414
Brazil	(11) 4197 3600
Mexico	01800 5064 800
United States	(800) 829 4444

Asia Pacific

Australia	1 800 629 485
China	800 810 0189
Hong Kong	800 938 693
India	1 800 112 929
Japan	0120 (421) 345
Korea	080 769 0800
Malaysia	1 800 888 848
Singapore	1 800 375 8100
Taiwan	0800 047 866
Other AP Countries	(65) 375 8100

Europe & Middle East

Belgium	32 (0) 2 404 93 40
Denmark	45 45 80 12 15
Finland	358 (0) 10 855 2100
France	0825 010 700*
	*0.125 €/minute
Germany	49 (0) 7031 464 6333
Ireland	1890 924 204
Israel	972-3-9288-504/544
Italy	39 02 92 60 8484
Netherlands	31 (0) 20 547 2111
Spain	34 (91) 631 3300
Sweden	0200-88 22 55
United Kingdom	44 (0) 118 927 6201

For other unlisted countries:
www.agilent.com/find/contactus

(BP-3-1-13)

Product specifications and descriptions in this document subject to change without notice.

© Agilent Technologies, Inc. 2013
Published in USA, June 17, 2013
5091-6188E



Agilent Technologies