

# LTM4676EY

## Dual Step-Down $\mu$ Module Regulator with PMBus Power System Management

### DESCRIPTION

Demonstration circuit 1811A is a dual-output, high efficiency, high density,  $\mu$ Module<sup>®</sup> regulator with 4.5V to 26.5V input range. Each output can supply 13A maximum load current. The demo board has a [LTM<sup>®</sup>4676](#)  $\mu$ Module regulator, which is a dual 13A or single 26A step-down regulator with PMBus power system management. Please see LTM4676 data sheet for more detailed information

The DC1811A powers up to default settings and produces power based on configuration resistors without the need for any serial bus communication. This allows easy evaluation of the DC/DC converter. To fully explore the extensive power system management features of the part, download the GUI software LTpowerPlay<sup>™</sup> onto your PC and use LTC's I<sup>2</sup>C/SMBus/PMBus dongle DC1613A to connect to

the board. LTpowerPlay allows the user to reconfigure the part on the fly and store the configuration in EEPROM, view telemetry of voltage, current, temperature and fault status

### GUI Download

The software can be downloaded from:

<http://www.linear.com/ltpowerplay>

For more details and instructions of LTpowerPlay, please refer to LTpowerPlay GUI for LTM4676 Quick Start Guide.

**Design files for this circuit board are available at <http://www.linear.com/demo>**

LT, LT, LTC, LTM, Linear Technology and the Linear logo are registered trademarks and LTpowerPlay is a trademark of Linear Technology Corporation. All other trademarks are the property of their respective owners.

### BOARD PHOTO

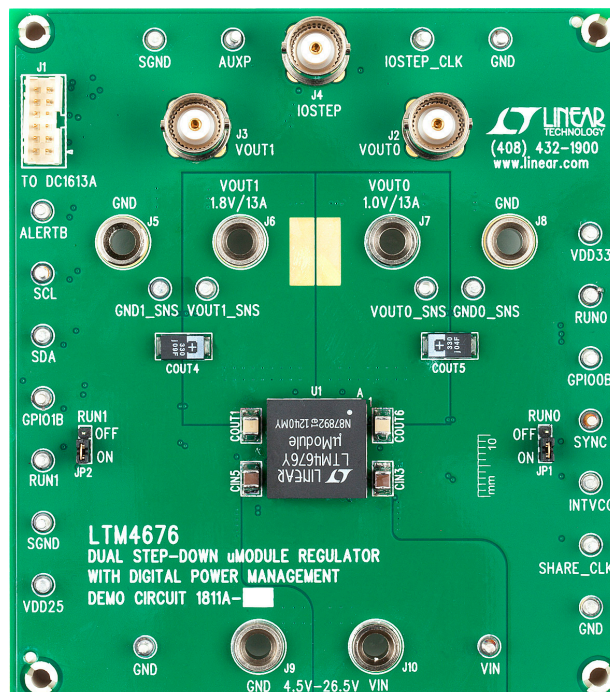

Figure 1. Dual-Output LTM4676/DC1811A Demo Circuit

# DEMO MANUAL DC1811A

## PERFORMANCE SUMMARY (T<sub>A</sub> = 25°C)

PARAMETER	CONDITION	VALUE
Input Voltage Range		4.5V to 26.5V
Output Voltage, V <sub>OUT0</sub>	V <sub>IN</sub> = 4.5V to 26.5V, I <sub>OUT0</sub> = 0A to 13A	0.5V to 4V, Default: 1V
Maximum Output Current, I <sub>OUT0</sub>	V <sub>IN</sub> = 4.5V to 26.5V, V <sub>OUT</sub> = 0.5V to 4V	13A
Output Voltage, V <sub>OUT1</sub>	V <sub>IN</sub> = 4.5V to 26.5V, I <sub>OUT1</sub> = 0A to 13A	0.5V to 5.4V, Default: 1.8V
Maximum Output Current, I <sub>OUT1</sub>	V <sub>IN</sub> = 4.5V to 26.5V, V <sub>OUT</sub> = 0.5V to 5.4V	13A
Typical Efficiency	V <sub>IN</sub> = 12V, V <sub>OUT</sub> = 1.8V, I <sub>OUT</sub> = 13A	86.3%
Default Switching Frequency		500kHz

## QUICK START PROCEDURE

Table 1. LTM4676 Demo Cards for Up to 100A Point-of-Load Regulation

MAXIMUM OUTPUT CURRENT	NUMBER OF OUTPUT VOLTAGES	NUMBER OF LTM4676 $\mu$ MODULE REGULATORS ON THE BOARD	DEMO BOARD NUMBER
13A, 13A	2	1	DC1811A
50A	1	2	DC1989A-A
75A	1	3	DC1989A-B
100A	1	4	DC1989A-C

Demonstration circuit 1811A is easy to set up to evaluate the performance of the LTM4676EY. Refer to Figure 2 for the proper measurement equipment setup and follow the procedure below.

1. With power off, connect the input power supply to VIN (4.5V to 26.5V) and GND (input return).
2. Connect the 1.0V output load between VOUT0 and GND (Initial load: no load).
3. Connect the 1.8V output load between VOUT1 and GND (Initial load: no load).
4. Connect the DVMs to the input and outputs. Set default jumper position: JP1: ON; JP2: ON.
5. Turn on the input power supply and check for the proper output voltages. V<sub>OUT0</sub> should be 1.0V  $\pm$  1%, and V<sub>OUT1</sub> should be 1.8  $\pm$  1%.
6. Once the proper output voltages are established, adjust the loads within the operating range and observe the output voltage regulation, ripple voltage and other parameters.

7. Connect the dongle and control the output voltages from the GUI. See “LTpowerPlay GUI for the LTM4676 Quick Start Guide” for details.

Note: When measuring the output or input voltage ripple, do not use the long ground lead on the oscilloscope probe. See Figure 3 for the proper scope probe technique. Short, stiff leads need to be soldered to the (+) and (–) terminals of an output capacitor. The probe’s ground ring needs to touch the (–) lead and the probe tip needs to touch the (+) lead.

### Connecting a PC to DC1811A

You can use a PC to reconfigure the power management features of the LTM4676 such as: nominal V<sub>OUT</sub>, margin set points, OV/UV limits, temperature fault limits, sequencing parameters, the fault log, fault responses, GPIOs and other functionality. The DC1613A dongle may be plugged when V<sub>IN</sub> is present.

**QUICK START PROCEDURE**

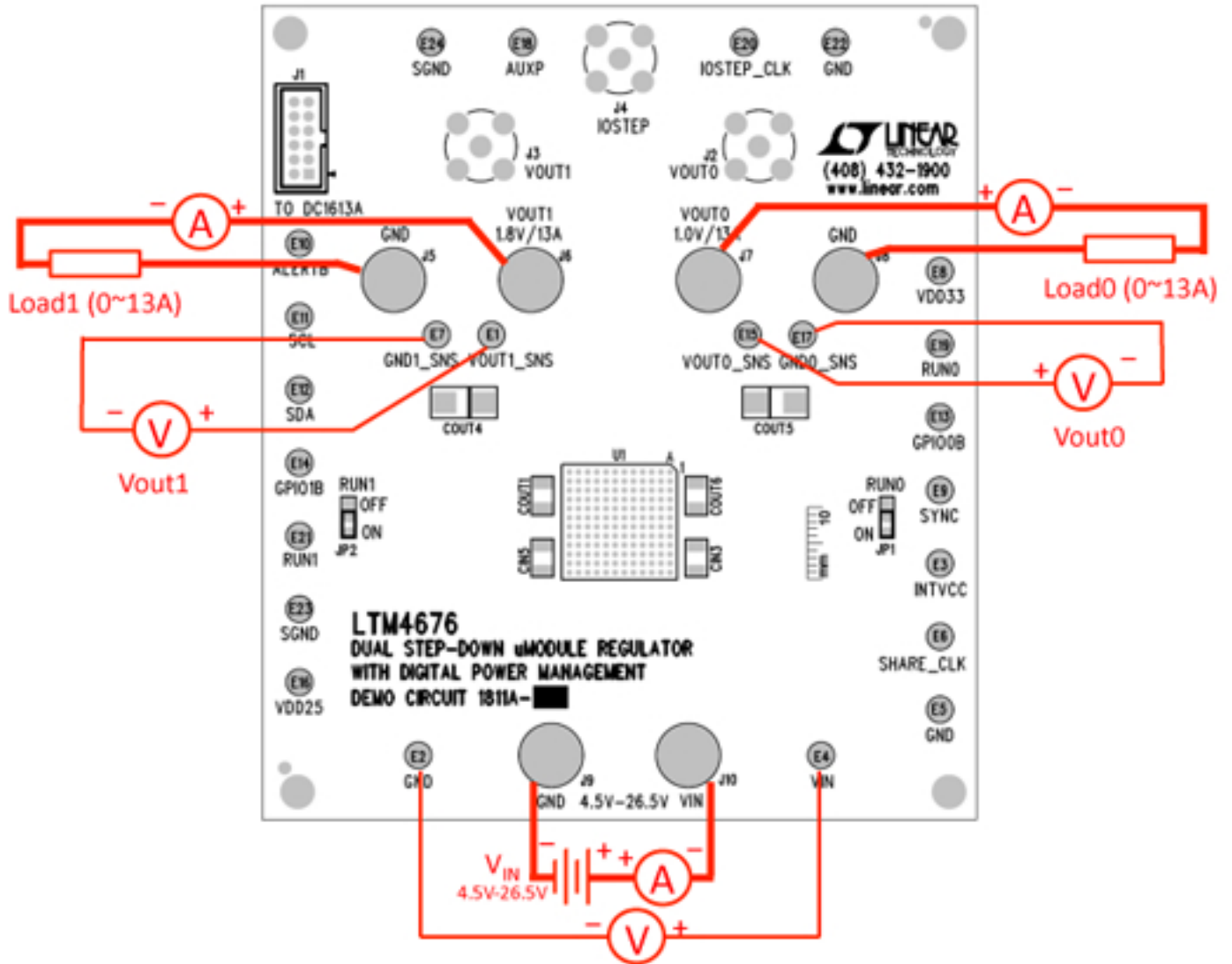

Figure 2. Proper Measurement Equipment Setup

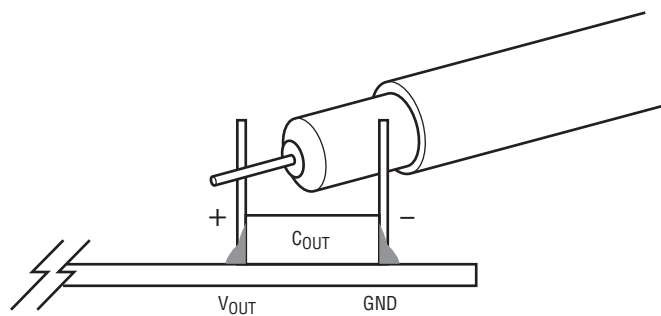

Figure 3. Measuring Output Voltage Ripple

## QUICK START PROCEDURE

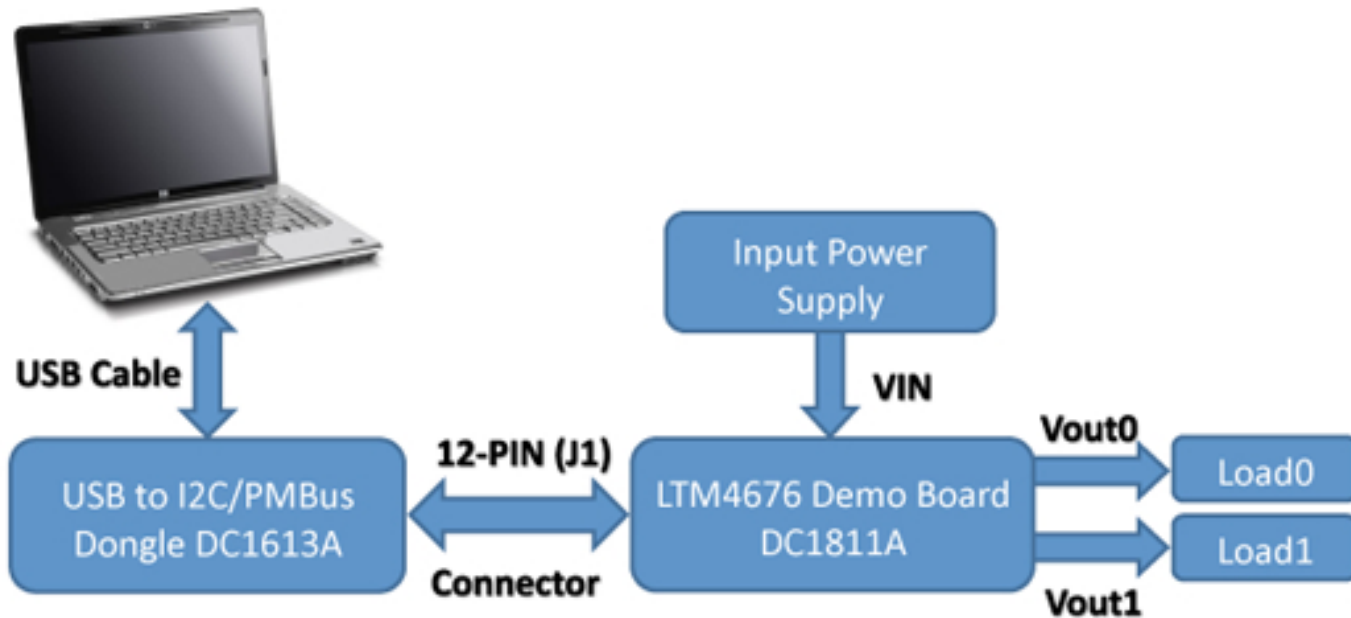

Figure 4. Demo Setup with PC

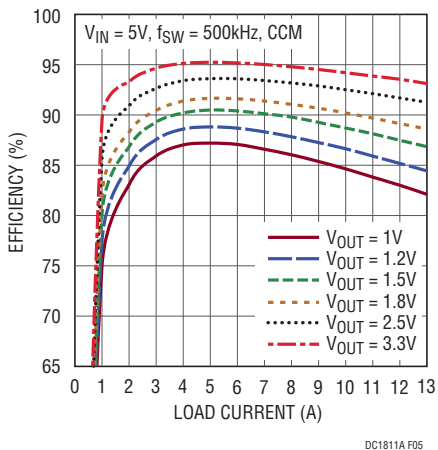

Figure 5. Efficiency vs Load Current at  $V_{IN} = 5V$

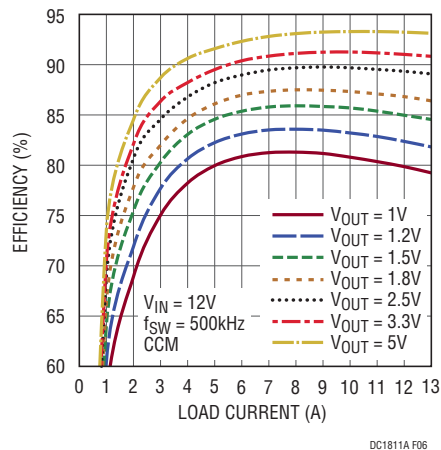

Figure 6. Efficiency vs Load Current at  $V_{IN} = 12V$

## QUICK START PROCEDURE

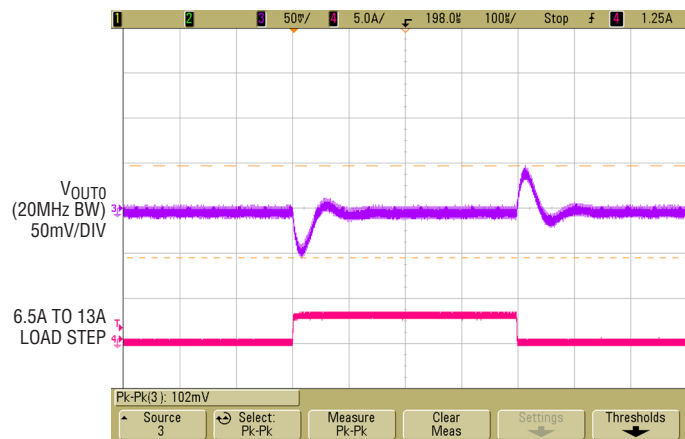

Figure 7. Output Voltage  $V_{OUT0}$  vs Load Current ( $V_{OUT0}$  RANGE = 0)

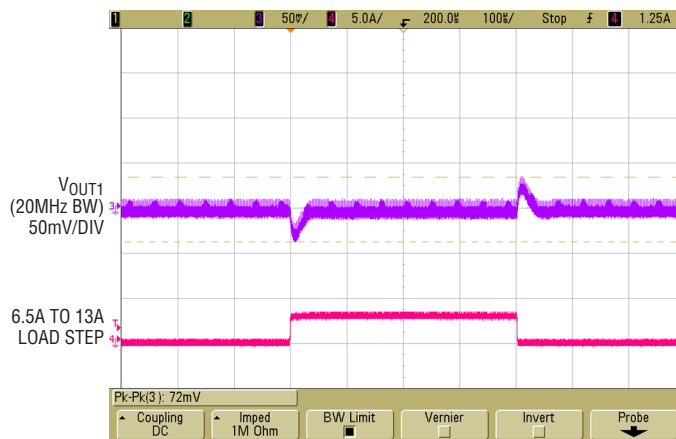

Figure 8. Output Voltage  $V_{OUT1}$  vs Load Current ( $V_{OUT1}$  Range = 1)

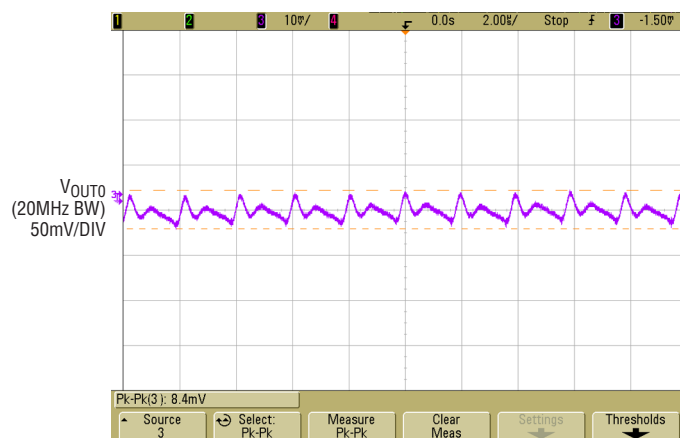

Figure 9. Output Voltage Ripple at  $V_{IN} = 12V$ ,  $V_{OUT0} = 1V$ ,  $I_{OUT0} = 13A$

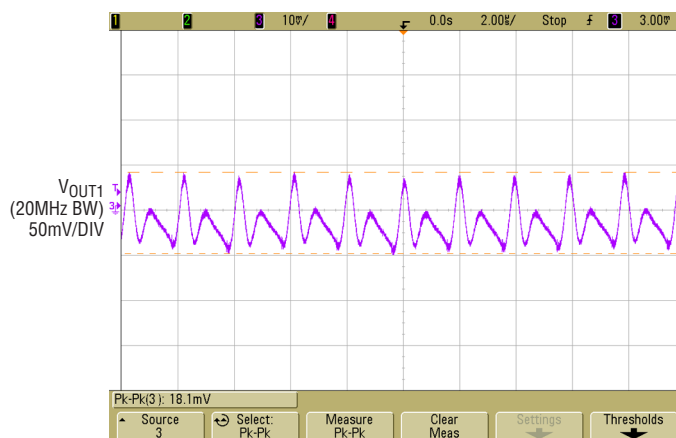

Figure 10. Output Voltage Ripple at  $V_{IN} = 12V$ ,  $V_{OUT1} = 1.8V$ ,  $I_{OUT1} = 13A$

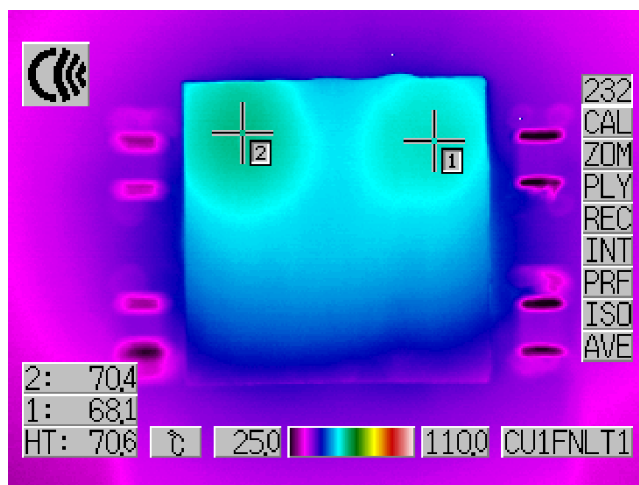

Figure 11. Thermal performance at  $V_{IN} = 12V$ ,  $V_{OUT0} = 1.0V$ ,  $I_{OUT0} = 13A$ ,  $V_{OUT1} = 1.8V$ ,  $I_{OUT1} = 13A$ ,  $T_A = 24^\circ C$ , 200LFM Airflow

## LTpowerPlay SOFTWARE GUI

LTpowerPlay is a powerful Windows-based development environment that supports Linear Technology power system management ICs, including the LTM4676, LTC3880, LTC3883, LTC2974 and LTC2978. The software supports a variety of different tasks. You can use LTpowerPlay to evaluate Linear Technology ICs by connecting to a demo board system. LTpowerPlay can also be used in an offline mode (with no hardware present) in order to build a multichip configuration file that can be saved and reloaded at a later time. LTpowerPlay provides unprecedented diagnostic and debug features. It becomes a valuable diagnostic tool during board bring-up to program or tweak the power management scheme in a system, or to diagnose power

issues when bringing up rails. LTpowerPlay utilizes the DC1613A USB-to-SMBus controller to communicate with one of many potential targets, including the LTM4676, the LTC3880 and the LTC3883's demo system, or a customer board. The software also provides an automatic update feature to keep the software current with the latest set of device drivers and documentation. The LTpowerPlay software can be downloaded from:

<http://www.linear.com/ltpowerplay>

To access technical support documents for LTC Digital Power Products visit Help. View online help on the LTpowerPlay menu.

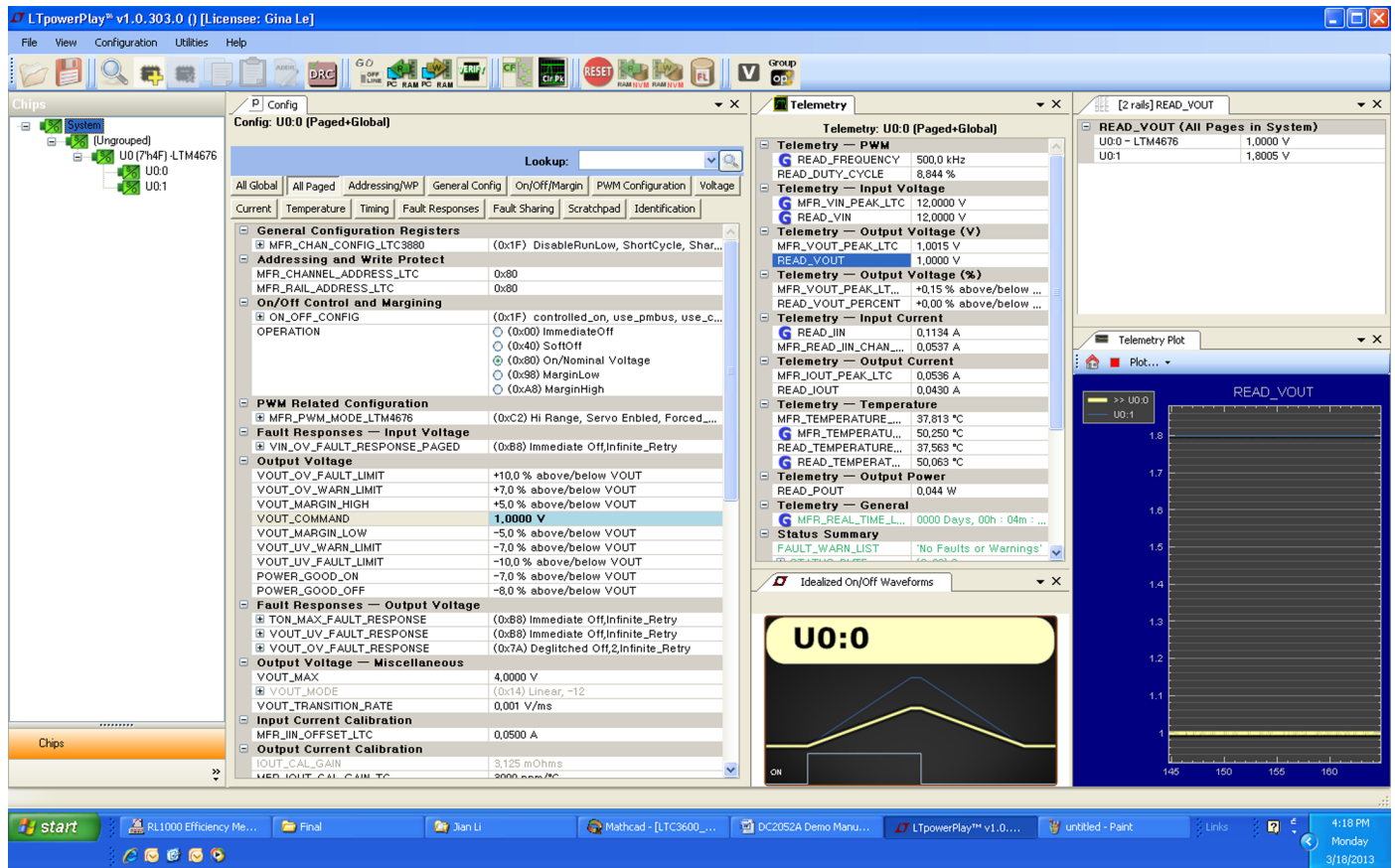

Figure 12. LTpowerPlay Main Interface

## LTpowerPlay QUICK START GUIDE

The following procedure describes how to use LTpowerPlay to monitor and change the settings of LTM4676.

1. Download and install the LTpowerPlay GUI:

<http://www.linear.com/ltpowerplay>

2. Launch the LTpowerPlay GUI.

- a. The GUI should automatically identify the DC1811A. The system tree on the left hand side should look like this:

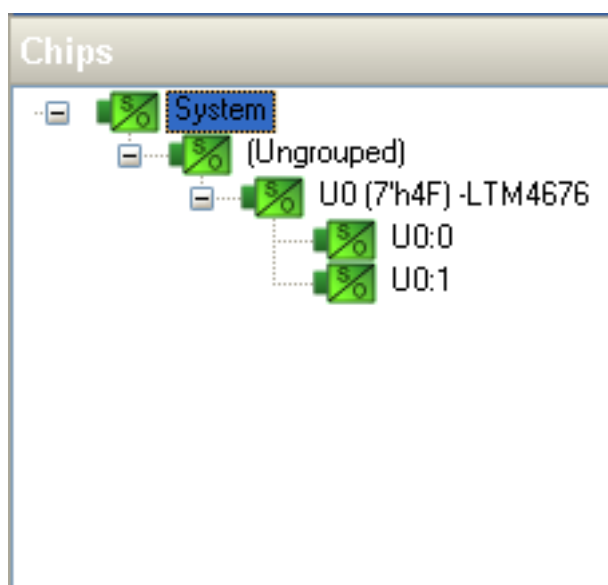

- b. A green message box shows for a few seconds in the lower left hand corner, confirming that LTM4676 is communicating:

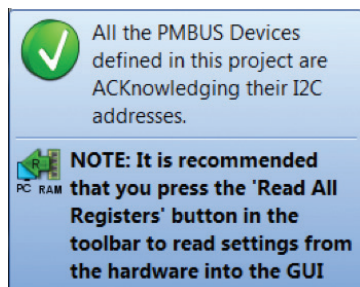

- c. In the Toolbar, click the “R” (RAM to PC) icon to read the RAM from the LTM4676. This reads the configuration from the RAM of LTM4676 and loads it into the GUI.



- d. If you want to change the output voltage to a different value, like 1.5V. In the Config tab, type in 1.5 in the VOUT\_COMMAND box, like this:

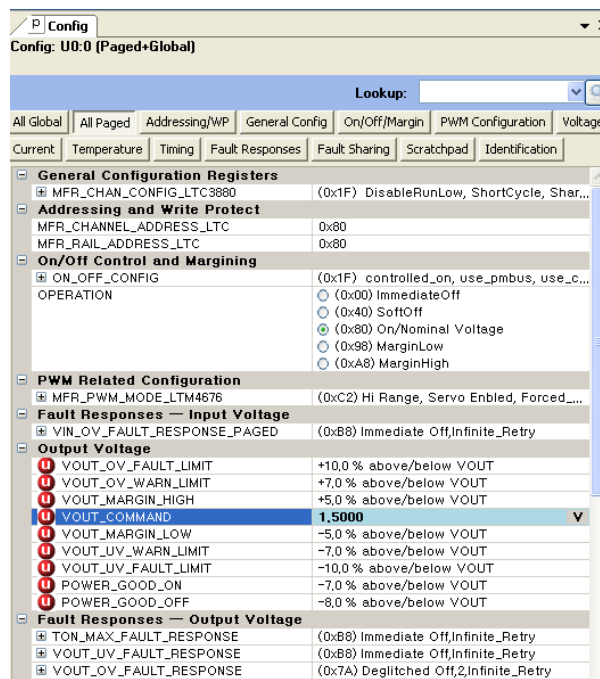

Then, click the “W” (PC to RAM) icon to write these register values to the LTM4676. After finishing this step, you will see the output voltage will change to 1.5V.



## LTpowerPlay QUICK START GUIDE

If the write is successful, you will see the following message:

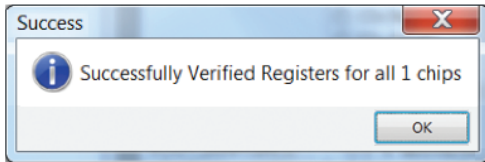

e. You can save the changes into the NVM. In the tool bar, click "RAM to NVM" button, as following



f. Save the demo board configuration to a (\*.proj) file. Click the Save icon and save the file. Name it whatever you want.



## PARTS LIST

ITEM	QTY	REFERENCE	PART DESCRIPTION	MANUFACTURER/PART NUMBER
<b>Required Circuit Components</b>				
1	1	CIN1	CAP., 150µF, 35V, ALUMINUM ELECTR.	SUN ELECT., 35CE150AX
2	4	CIN2, CIN3, CIN4, CIN5	CAP., X5R, 10µF, 35V, 10%,1210	MURATA, GRM32ER6YA106KA12
3	6	COU1-COU3, COU6-COU8	CAP., X5R, 100µF, 6.3V, 20% 1210	AVX, 12106D107MAT2A
4	2	COU4, COU5	CAP., 330µF, 6.3V, POSCAP, D3L	SANYO, 6TPF330M9L
5	2	C1, C14	CAP., X7R, 2200pF, 25V, 10%, 0603	AVX, 06033C222KAT2A
6	1	C20	CAP., X5R, 100nF, 16V, 10%,0603	AVX, 0603YD104KAT
7	1	C23	CAP., X7R, 1µF, 25V,10%, 0805	AVX, 08053C105KAT2A
8	3	C21, C22, C24	CAP., X5R, 1µF, 25V,10%, 0603	AVX, 06033D105KAT2A
9	2	JP1, JP2	HEADER 3-PIN 0.079 SINGLE ROW	SAMTEC, TMM103-02-L-S
10	3	J2-J4	CONN, BNC, 5 PINS	CONNEX, 112404
11	1	J1	CONN HEADER 12 POS 2MM STR DL PCB	FCI 98414-G06-12ULF
12	6	J5-J10	BANANA SMALL	KEYSTONE, 575-4
13	1	Q1	N-CHANNEL 30-V MOSFET	VISHAY, SUD50N03-09P
14	7	R3, R5, R7, R9, R25, R31, R32	RES., CHIP, 0Ω, 1%, 0603	NIC, NRC06Z0000TRF
15	13	R10-R16, R18, R19, R24, R46, R47, R52	RES., CHIP, 10k, 1%, 0603	NIC, NRC06F1002TRF
16	1	R30	RES., CHIP, 6.34k, 1%, 0603	VISHAY, CRCW06036K34FKEA
17	3	R2, R44, R45	RES., CHIP, 4.99k, 1%, 0603	NIC, NRC06F4991TRF
18	1	R22	RES., CHIP, 4.22k, 1%, 0603	VISHAY, CRCW06034K22FKEA
19	1	R48	RES., CHIP, 0Ω, 0.5W, 2010	NIC, NRC50ZOTRF
20	1	R53	RES., CHIP, 0.01Ω, 1/2W, 1%, 2010	VISHAY, WSL2010R0100FEA
21	1	U1	IC, LTM4676EY#PBF	LINEAR TECH. LTM4676EY#PBF
22	1	U2	IC, 24LC025T-E/OT SOT-23 6-LEAD	MICROCHIP, 24LC025T-E/OT
<b>Additional Demo Board Circuit Components</b>				
1	0	C2, C15-C17 (OPT)	CAP., 0603	
2	0	R8, R26-R29, R33-R39, R41 (OPT)	RES., 0603	
3	0	R4, R6, R20, R23, R49 (OPT)	RES., CHIP OPTIONAL	
4	0	R50, R51 (OPT)	RES., CHIP, 30, 1%, 2010	
<b>Hardware-For Demo Board Only</b>				
1	24	E1-E24	TESTPOINT, TURRET, 0.062"	MILL-MAX, 2308-2-00-80-00-00-07-0
2	2	XJP1, XJP2	SHUNT	SAMTEC, 2SN-BK-G
3	4	(STAND-OFF)	STAND-OFF, NYLON 0.50" tall	KEYSTONE, 8833(SNAP ON)
4	1		FAB, PRINTED CIRCUIT BOARD	DEMO CIRCUIT 1811A

# DEMO MANUAL DC1811A

## SCHEMATIC DIAGRAM

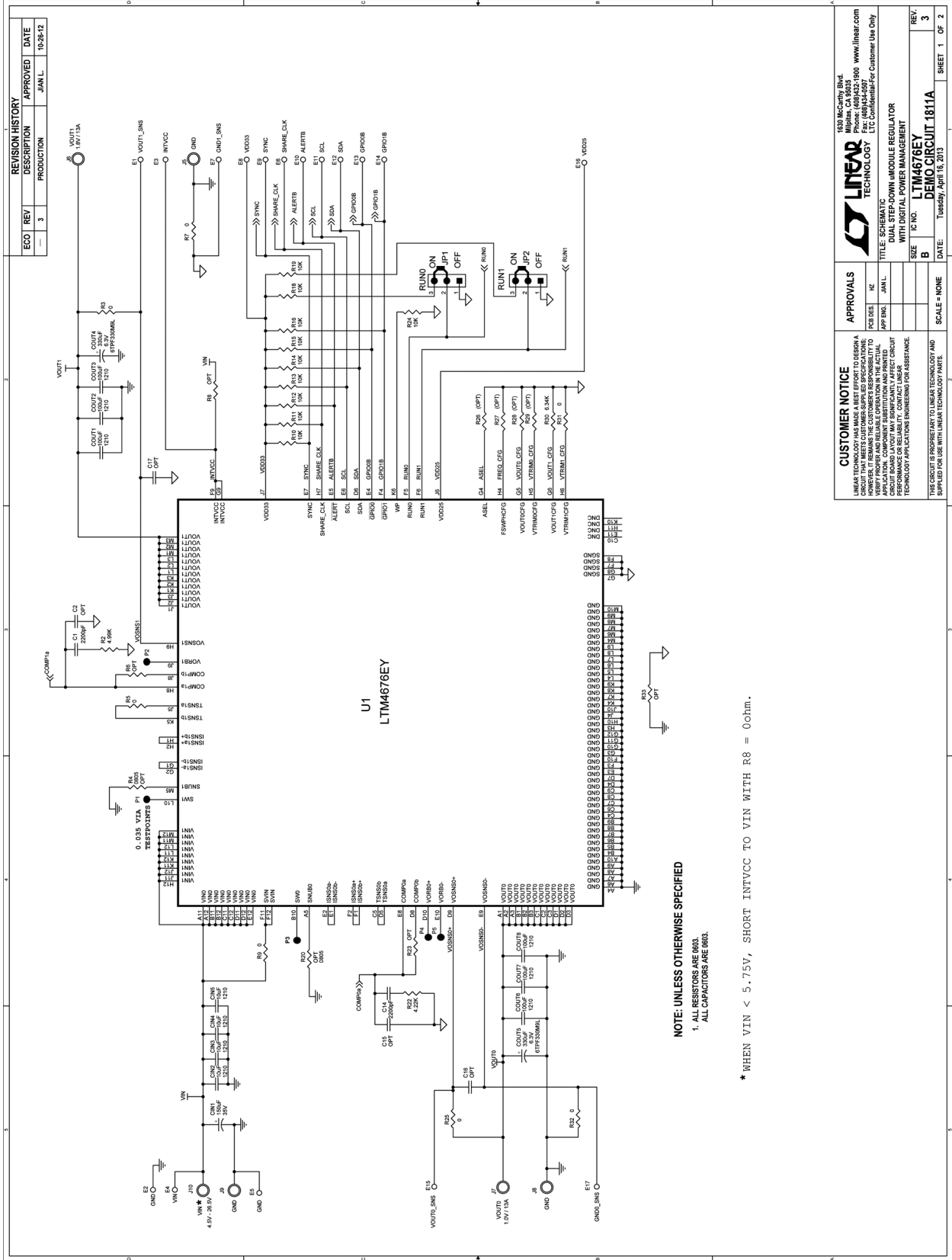

REVISION HISTORY			
ECO	REV	DESCRIPTION	APPROVED DATE
—	3	PRODUCTION	JAN.L. 10-26-12

**LINER TECHNOLOGY**  
1630 McCarty Blvd.  
Milpitas, CA 95035  
Tel: (408) 255-2000  
Fax: (408) 255-2007

**CUSTOMER NOTICE**  
LINER TECHNOLOGY ASSUMES NO LIABILITY FOR THE USE OF THIS SCHEMATIC IN ANY APPLICATION. COMPONENT SUBSTITUTION AND PRINTED BOARD MANUFACTURING VARIATIONS MAY AFFECT CIRCUIT PERFORMANCE OR RELIABILITY. CONTACT LINER TECHNOLOGY APPLICATIONS ENGINEERING FOR ASSISTANCE.

**APPROVALS**

POB DES.	IC
APP BKG.	JAN.L.

**SCALE - NONE**

**SIZE** B  
**IC NO.** LTM4676EY  
**TITLE:** SCHEMATIC TECHNOLOGY DEMO CIRCUIT 1811A WITH DIGITAL POWER MANAGEMENT

**DATE:** Tuesday, April 10, 2012  
**REV.** 3  
**SHEET** 1 OF 2

**NOTE: UNLESS OTHERWISE SPECIFIED**  
1. ALL RESISTORS ARE 0603.  
ALL CAPACITORS ARE 0603.

\* WHEN VIN < 5.75V, SHORT INTVCC TO VIN WITH R8 = 0ohm.

**SCHEMATIC DIAGRAM**

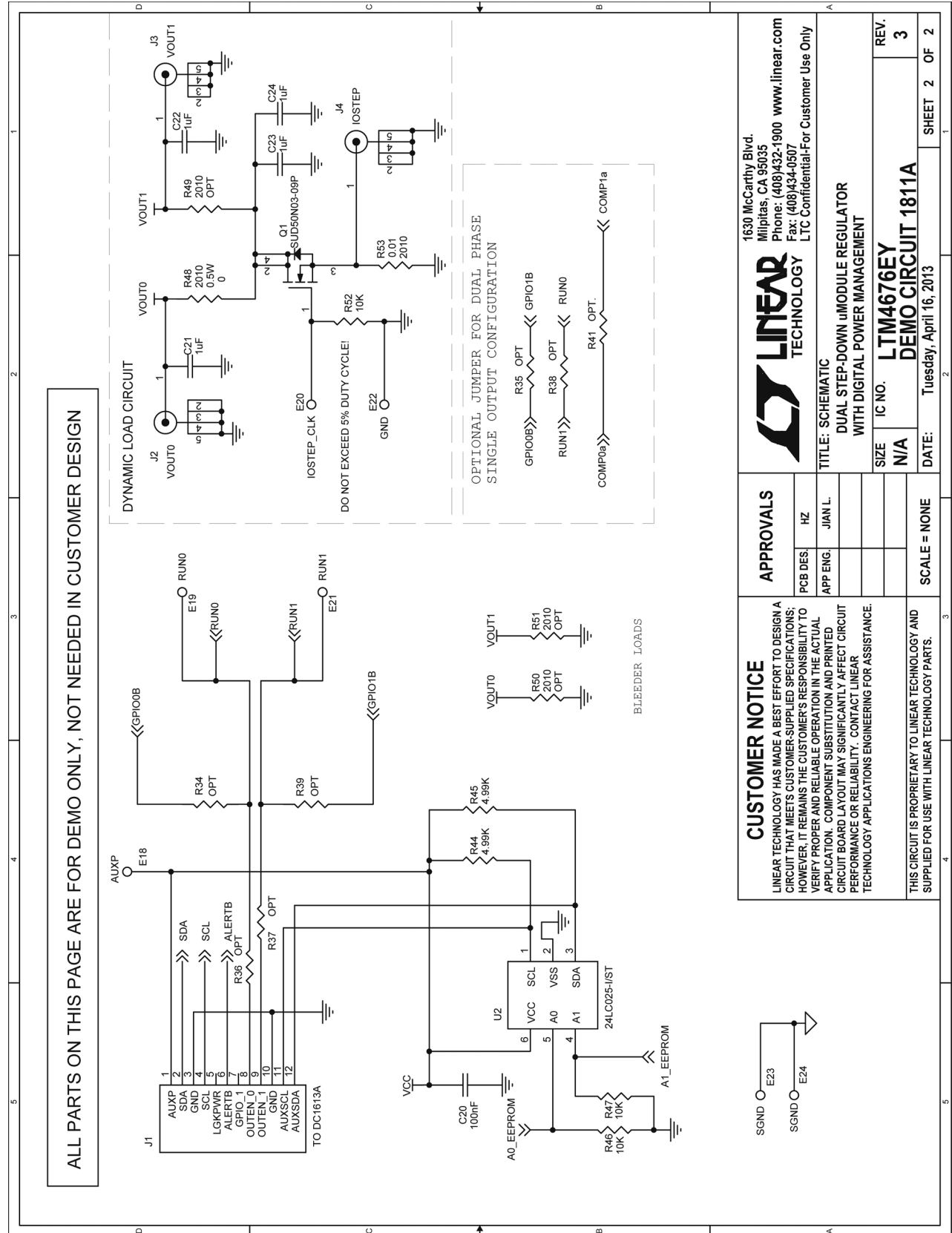

**LINEAR TECHNOLOGY**  
 1630 McCarthy Blvd.  
 Milpitas, CA 95035  
 Phone: (408)432-1900 www.linear.com  
 Fax: (408)434-0507  
 LTC Confidential-For Customer Use Only

**TITLE: SCHEMATIC**  
**DUAL STEP-DOWN uMODULE REGULATOR WITH DIGITAL POWER MANAGEMENT**

SIZE: N/A IC NO: **LTM4676EY** REV. **3**  
 DEMO CIRCUIT 1811A

DATE: Tuesday, April 16, 2013 SHEET 2 OF 2

APPROVALS	
PCB DES	HZ
APP ENG	JIAN L.
SCALE	NONE

**CUSTOMER NOTICE**  
 LINEAR TECHNOLOGY HAS MADE A BEST EFFORT TO DESIGN A CIRCUIT THAT MEETS CUSTOMER-SUPPLIED SPECIFICATIONS; HOWEVER, IT REMAINS THE CUSTOMER'S RESPONSIBILITY TO VERIFY PROPER AND RELIABLE OPERATION IN THE ACTUAL APPLICATION. COMPONENT SUBSTITUTION AND PRINTED CIRCUIT BOARD LAYOUT MAY SIGNIFICANTLY AFFECT CIRCUIT PERFORMANCE OR RELIABILITY. CONTACT LINEAR TECHNOLOGY APPLICATIONS ENGINEERING FOR ASSISTANCE.

THIS CIRCUIT IS PROPRIETARY TO LINEAR TECHNOLOGY AND SUPPLIED FOR USE WITH LINEAR TECHNOLOGY PARTS.



Information furnished by Linear Technology Corporation is believed to be accurate and reliable. However, no responsibility is assumed for its use. Linear Technology Corporation makes no representation that the interconnection of its circuits as described herein will not infringe on existing patent rights.

# DEMO MANUAL DC1811A

---

## DEMONSTRATION BOARD IMPORTANT NOTICE

Linear Technology Corporation (LTC) provides the enclosed product(s) under the following **AS IS** conditions:

This demonstration board (DEMO BOARD) kit being sold or provided by Linear Technology is intended for use for **ENGINEERING DEVELOPMENT OR EVALUATION PURPOSES ONLY** and is not provided by LTC for commercial use. As such, the DEMO BOARD herein may not be complete in terms of required design-, marketing-, and/or manufacturing-related protective considerations, including but not limited to product safety measures typically found in finished commercial goods. As a prototype, this product does not fall within the scope of the European Union directive on electromagnetic compatibility and therefore may or may not meet the technical requirements of the directive, or other regulations.

If this evaluation kit does not meet the specifications recited in the DEMO BOARD manual the kit may be returned within 30 days from the date of delivery for a full refund. THE FOREGOING WARRANTY IS THE EXCLUSIVE WARRANTY MADE BY THE SELLER TO BUYER AND IS IN LIEU OF ALL OTHER WARRANTIES, EXPRESSED, IMPLIED, OR STATUTORY, INCLUDING ANY WARRANTY OF MERCHANTABILITY OR FITNESS FOR ANY PARTICULAR PURPOSE. EXCEPT TO THE EXTENT OF THIS INDEMNITY, NEITHER PARTY SHALL BE LIABLE TO THE OTHER FOR ANY INDIRECT, SPECIAL, INCIDENTAL, OR CONSEQUENTIAL DAMAGES.

The user assumes all responsibility and liability for proper and safe handling of the goods. Further, the user releases LTC from all claims arising from the handling or use of the goods. Due to the open construction of the product, it is the user's responsibility to take any and all appropriate precautions with regard to electrostatic discharge. Also be aware that the products herein may not be regulatory compliant or agency certified (FCC, UL, CE, etc.).

No License is granted under any patent right or other intellectual property whatsoever. **LTC assumes no liability for applications assistance, customer product design, software performance, or infringement of patents or any other intellectual property rights of any kind.**

LTC currently services a variety of customers for products around the world, and therefore this transaction **is not exclusive**.

**Please read the DEMO BOARD manual prior to handling the product.** Persons handling this product must have electronics training and observe good laboratory practice standards. **Common sense is encouraged.**

This notice contains important safety information about temperatures and voltages. For further safety concerns, please contact a LTC application engineer.

Mailing Address:

Linear Technology  
1630 McCarthy Blvd.  
Milpitas, CA 95035

Copyright © 2004, Linear Technology Corporation