



# XA-1

## 3D Mini HDMI Analyser

### OPERATION MANUAL



## • **Safety Precautions**

Please read all instructions before attempting to unpack or install or operate this equipment, and before connecting the power supply. Please keep the following in mind as you unpack and install this equipment:

- Always follow basic safety precautions to reduce the risk of fire, electrical shock and injury to persons.
- To prevent fire or shock hazard, do not expose the unit to rain, moisture or install this product near water.
- Never spill liquid of any kind on or into this product.
- Never push an object of any kind into this product through module openings or empty slots, as you may damage parts.
- Do not attach the power supply cabling to building surfaces.
- Do not allow anything to rest on the power cabling or allow it to be abused by persons walking on it.
- To protect the equipment from overheating, do not block the slots and openings in the module housing that provide ventilation.

## • **Revision History**

<u>Version No</u>	<u>Date</u>	<u>Summary of Change</u>
<b>RDV2</b>	<b>20110118</b>	<b>Preliminary Release</b>

# Table of Contents

<b>1. Introduction</b> .....	<b>1</b>
<b>2. Applications</b> .....	<b>1</b>
<b>3. Package Contents</b> .....	<b>1</b>
<b>4. System Requirements</b> .....	<b>1</b>
<b>5. Features</b> .....	<b>1</b>
<b>6. Specifications</b> .....	<b>2</b>
<b>7. Hardware Description</b> .....	<b>3</b>
7.1 Front Panel.....	3
7.2 Rear Panel .....	3
7.3 Top Panel .....	4
<b>8. OSD Menu</b> .....	<b>5</b>
8.1 System Info.....	5
8.2 Sink Edid .....	6
8.3 Source Infoframe .....	6
8.4 Input Select.....	6
8.5 Audio Return.....	6
8.6 Exit.....	6
<b>9. OLED</b> .....	<b>7</b>
<b>10. Timing Table</b> .....	<b>7</b>
<b>11. Support Pattern Table</b> .....	<b>8</b>
<b>12. Connection and Installation</b> .....	<b>10</b>

## **1. Introduction**

The 3D mini HDMI Analyzer is a tool for checking both source and display devices. With touch button control and built-in OLED (Organic Light Emitting Diode) it can show status of both input and output device. The major purpose is to analyze input source info-frame and output sink EDID. Another purpose is to use built-in pattern to test output device.

## **2. Applications**

- Apparatus testing
- Equipment adjustment
- EDID checking
- HDCP verification
- Production testing
- RD design

## **3. Package Contents**

- 3D Mini HDMI Analyzer
- Operation Manual
- 5V Power Adaptor

## **4. System Requirements**

HDMI input port connected to the source/HDMI system with HDMI port and output connected to the display/HDMI system with HDMI port.

## **5. Features**

- Supports Timing include SD, HD up to 1080p, PC up to WUXGA and 3D
- Provides 25 timings, 6 patterns and 1 pattern for 3D timing
- Deep color video up to 12 bits, 1080p@60Hz
- Support input signal bypass, digital video formats in Deep Color Mode at up to 36 bits (12 bits/color) and new lossless compressed (Dolby TrueHD, Dolby Digital Plus and DTS-HD master Audio) digital audio
- Supports internal pattern audio LPCM 2CH 48/96/192KHz, LPCM 5.1CH 48/96KHz, LPCM 7.1CH 48/96KHz. LPCM 2CH has a single-tone sound; LPCM 5.1CH has a dual-tone sound; LPCM 7.1CH has a tri-tone sound. To confirm whether you are receiving 5.1 or 7.1, listen for the dual and tri-tone audio from the device.
- Analyze input source info-frame and output sink EDID
- Touch button control function
- OLED show Input / Output timing information
- Support ARC (Audio Return Channel) follow by HDMI v1.4 specification

## 6. Specifications

TMDS Clock Frequency	225MHz
Input Port	1 x HDMI (Female type)
Output port	1 x HDMI (Female type)
EXT Mode (HDMI input)	
HDMI Resolution	480i/p, 576i/p, 720p~1080p
PC Resolution	VGA~SXGA, WUXGA
3D Resolution	Support all 3D timing
INT Mode (internal pattern)	
HDMI Resolution	480i/p, 576i/p, 720p~1080p
PC Resolution	VGA~SXGA, WUXGA
3D Resolution	Frame Packing (720p@50, 1080p@24) Side-by-Side (Half) (1080p@24, 720p@50/60) Top-and-Bottom (1080p@24/, 720p@50/60)
ESD Protection	Human Body model: $\pm 8\text{kV}$ (air-gap discharge) $\pm 4\text{kV}$ (contact discharge)
Power Supply	5V/1A DC (US/EU standards, CE/FCC/UL certified)
Dimensions (mm)	119.5 (W) x 70 (D) x 25 (H)
Weight(g)	200
Chassis Material	Plastic
Silkscreen Color	Upper Black lower Silver
Operating Temperature	0°C~40°C / 32°F ~ 104°F
Storage temperature	-20°C~60°C / -4°F ~ 140°F
Relative Humidity	20~90% RH (no condensation)
Power Consumption (W)	3W (Max)

## 7. Hardware Description

The following sections describe the hardware components of the unit.

### 7.1 Front Panel

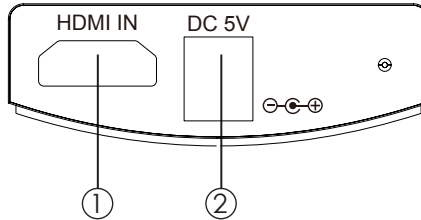

- ①. HDMI input: Connect the HDMI input port to the HDMI output port of your source equipment such as DVD, Computer, Cables Box or any other source for testing and pulling EDID file.
- ②. Power: Plug the DC 5V power supply into the splitter and connect the adaptor to AC wall outlet.

### 7.2 Rear Panel

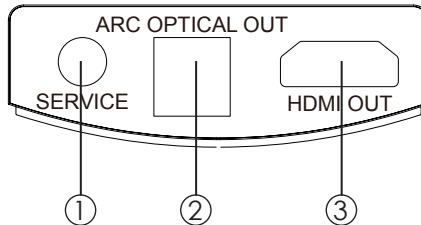

- ①. Service: Use DB9 to 3.5φ phone jack to do the software upgrade yet this feature is not open to end user. The DB9 to 3.5φ phone jack is not included in the package.
- ②. ARC/Optical out:  
For the ARC, the user had a TV with a built-in tuner or DVD player and wanted to send content "upstream" from the TV back to the audio system (such as Audio Video Receiver) to play any multi-channel audio. For the Optical, the HDMI input audio will send it to HDMI and Optical output port simultaneously.
- ③. HDMI out: This connection is for connecting the generator to a display or devices before the display when testing the full system capabilities.

### 7.3 Top Panel

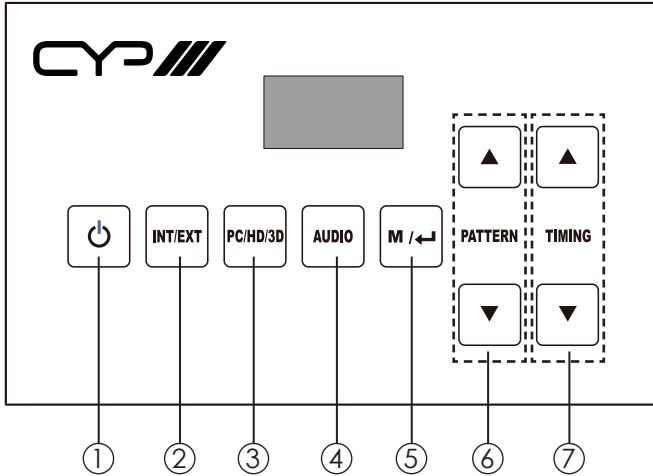

- ① Power: Press this button to turn on or set the device to standby mode.
- ② INT/EXT: Press this button to select the internal patterns built-in the device or the external source device connected from the input port. To use this function the input slot must be connected with source signal in order to perform the function if not, the device will only send out the internal patterns to display on the TV/monitor.
- ③ PC/HD/3D: Press this button to switch patterns quickly from PC/HD or 3D and the OLED will display the patterns for users selection.
- ④ AUDIO: Press this button to select audio's sample rate from LPCM 2Ch, LPCM 5.1CH and LPCM 7.1CH 48KHz or LPCM 2Ch, LPCM 5.1CH and LPCM 7.1CH 96KHz or LPCM 2Ch and LPCM 5.1CH 192KHz.
- ⑤ M / ← : Press this manual to enter into OSD manual and or return to the manual.
- ⑥ PATTERN ▲/▼: Press these keys to select patterns or when in OSD manual press these keys to select for option.
- ⑦ TIMING ▲/▼: Press these keys to select timings.

## 8. OSD Menu

Press the M/← button from the device to bring up the OSD on the display.

Press pattern's [▲/▼] to highlight on option

Press [M/←] to confirm /exit the selection

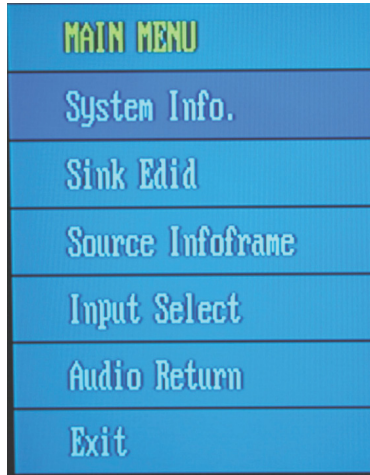

### 8.1 System Info

System Info.: Press this button to show both the input and output information while both input and output is connected, refers to below picture for information contents. When connection output display only, press this button repeatedly to bring up the patterns for display (Pattern details in section 9).



Press [M/←] to check the input/output device information and software version.



## 8.2 Sink Edid

Option	Description
Block Data	To check the sink Block0 and Block1's table of EDID
Description	To check the sink description of EDID

## 8.3 Source Infoframe

Option	Description
AVI (AVI infoframe data)	To check the source video infoFrame Packet
AUD (Audio infoframe data)	To check the source audio infoFrame Packet

## 8.4 CEC Command

Option	Description
Stand By	
Active Source	
Monitor (Read)	

## 8.5 Audio Return

Option	Description
Audio Return	On/Off

## 8.6 Exit

## 9. OLED

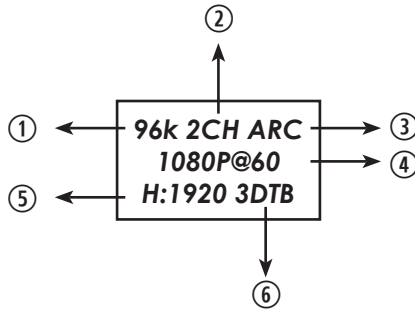









- ①. Sampling Rate: The device support audio sampling rate of 48/96/192KHz and the OLED will display it according to the selection, if external audio is selected the OLED will display bypass.
- ②. Audio Channels: The device support audio channels from LPCM 2, 5.1 and 7.1CH, if external audio is selected the OLED will display bypass.
- ③. ARC: Audio Return Channel, when the function is selected the OLED will display ARC if not, the OLED will not illuminate ARC.
- ④. Timing Frequency & V Sync : Please referes to section 10. Timing Table for the supports timing and V sync details.
- ⑤. H Sync: Please referes to section 10. Timing Table for the supports H sync details.
- ⑥. 3D PATTERN: Only when the 3D pattern is selected, the OLED will show the patter details.

## 10. Timing Table

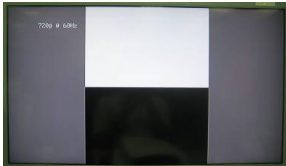
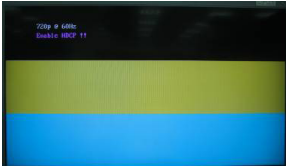
No.	Resolution	V Hz	No.	Resolution	V Hz
T01	480p	60	T14	1024x768	60
T02	480i	60	T15	1280x1024	60
T03	720P	60	T16	1920x1200	60
T04	1080i	60	T17	720p (3D Frame Packing)	60
T05	1080p	60	T18	720p (3D Side-by-Side)	60
T06	576i	50	T19	720p (3D Top-to-Bottom)	60
T07	576p	50	T20	720p (3D Frame Packing)	50
T08	720p	50	T21	720p (3D Side-by-Side)	50
T09	1080i	50	T22	720p (3D Top-to-Bottom)	50
T10	1080p	50	T23	1080p (3D Frame Packing)	24
T11	1080p	24	T24	1080p (3D Side-by-Side)	24
T12	640x480	60	T25	1080p (3D Top-to-Bottom)	24
T13	800x600	60			

## 11. Support Pattern Table

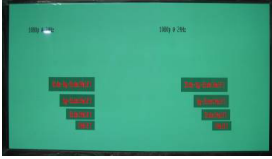
GROUP	NO.	PATTERN	Description
Standard Type	1		Primary colors: Red, Green, Blue  P1: Red P2: Green P3: Blue
	2		
	3		
	4		P4: Horizontal RGB Bar
	5		P5: H Grey Scale
	6		P6: HDCP handshaking and link-integrity test

3D Type	*7 (FP)		P*7(FP): Frame Packing
	*7 (SH)		P*7(SH): Side-by-Side (Half)
	*7 (TB)		P*7 (TB): Top-and-Bottom

Note: \*7 means Left hand side will present on 2D display, right hand side will present on 3D display.

3D FP means 3D Frame Packing

3D SH means 3D Side-by-Side (Half)

3D TB means 3D Top-and-Bottom

## 12. Connection and Installation

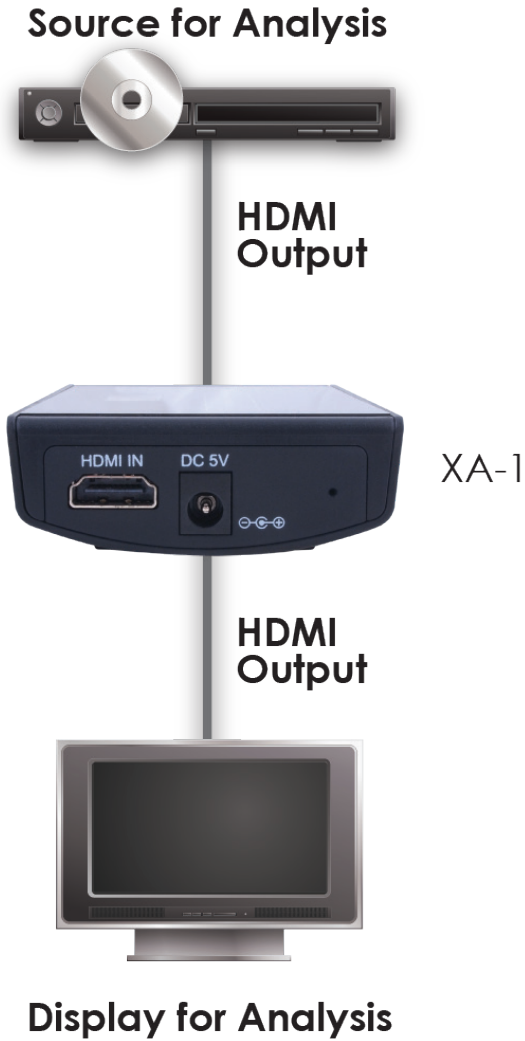

# Acronyms

---



## **Acronym**

## **Complete Term**

3D	3 Dimension
EDID	Extended Display Identification Data
HDCP	High-bandwidth Digital content protection
HDMI	High-Definition Multimedia Interface
SD	Standard Definition



[www.cypeurope.com](http://www.cypeurope.com)

