

INTERCONNECTS

SERIES 804 & 805 • .100" GRID (.030" DIA. PINS), HEADERS AND SOCKETS • TRIPLE ROW

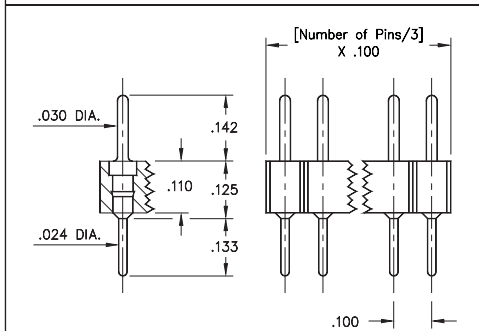
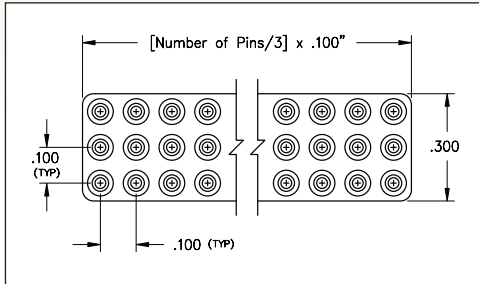

FIG. 1

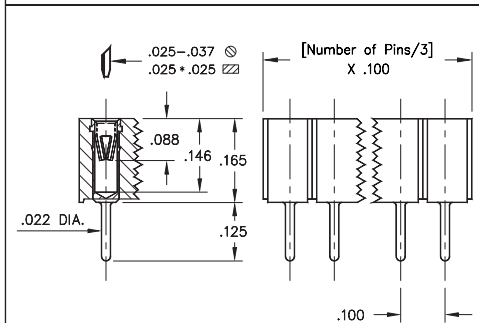
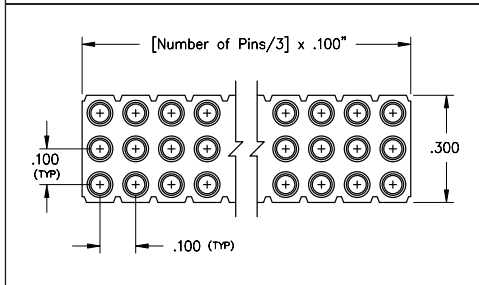
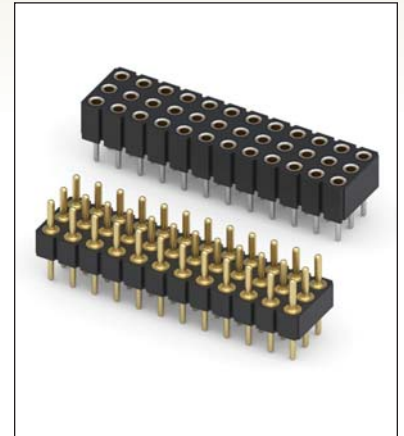

FIG. 2

- Series 804 triple row .100" grid headers uses MM #5016 pins. See page 215 for details
- Series 805 triple row .100" grid sockets uses MM #1303 pins. See page 180 for details
- Series 805 triple row .100" grid sockets uses Hi-Rel, 6-finger BeCu #47 contact rated at 4.5 amps. See page 256 for details
- Insulators are high temperature thermoplastic, suitable for all soldering operations



ORDERING INFORMATION

| | | | | | |
|---------------|---------------------------------|----------------------------------|--|--|--|
| FIG. 1 | Series 804...002 | Straight Pin Header | | | |
| | 804-10-0 | -10-002000 | | | |
| | Specify number of pins | 09-96 | | | |
| | RoHS-2 2011/65/EU | XX=Plating Code See Below | <i>For Electrical, Mechanical & Environmental Data, See page 264</i> | | |
| | SPECIFY PLATING CODE XX= | 10 | | | |
| | Pin Plating | 10 μ" Au | | | |

| | | | | | |
|---------------|---------------------------------|----------------------------------|--|--|-----------|
| FIG. 2 | Series 805...012 | Straight Pin Socket | | | |
| | 805-43-0 | -10-012000 | | | |
| | Specify number of pins | 09-96 | | | |
| | RoHS-2 2011/65/EU | XX=Plating Code See Below | <i>For Electrical, Mechanical & Environmental Data, See page 264</i> | | |
| | SPECIFY PLATING CODE XX= | | | | 43 |
| | Sleeve (Pin) | | | | 200 μ" Sn |
| | Contact (Clip) | | | | 30 μ" Au |

