

GENERAL SPECIFICATION (@25 °C)

| | |
|------------------------------|-------------------|
| NUMBER OF TERMINALS | 6, 8 OR 12 |
| ELECTRICAL RATING | |
| Nominal Voltage Rating: | 250 VOLTS |
| Nominal Current Rating: | 15 AMPS |
| DIELECTRIC STRENGTH | |
| Adjacent Terminals: | 2000 Vrms |
| Terminals To Bracket/Flange: | 2000 Vrms |
| TEMPERATURE | |
| Operating | -40 °C TO +125 °C |
| MISCELLANEOUS | |
| Wire Size: | 12/3.0 AWG/mm |
| Body Color: | Black |
| Weight: | 35, 45, 50 grams |

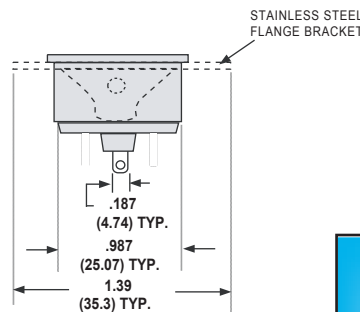

CHASSIS CUTOUT CHART

| PINS | LENGTH | WIDTH |
|------|-------------|---------------------|
| 6 | 1.61 (40.8) | 1.10 MAX. (27.9) |
| 8 | 2.05 (52) | |
| 12 | 2.94 (74.6) | |

Accepts Traffic Industry NEMA
 -Load Switches (12 pin)
 -Flash Transfer Relays (8 pin)
 -Flashers (6 pin)

| STRUTHERS-DUNN PART NUMBER | FORMER MAGNECRAFT PART NUMBER | DESCRIPTION |
|----------------------------|-------------------------------|--|
| SK-TRF6-FW | 70-TR6-1 | 6 PIN CHASSIS MOUNT WITH FLANGE BRACKET |
| SK-TRF8-FW | 70-TR8-1 | 8 PIN CHASSIS MOUNT WITH FLANGE BRACKET |
| SK-TRF12-FW | 70-TR12-1 | 12 PIN CHASSIS MOUNT WITH FLANGE BRACKET |
| SK-TRF6-BW | 70-TRB6-1 | 6 PIN CHASSIS MOUNT WITH END BRACKET |
| SK-TRF8-BW | 70-TRB8-1 | 8 PIN CHASSIS MOUNT WITH END BRACKET |
| SK-TRF12-BW | 70-TRB12-1 | 12 PIN CHASSIS MOUNT WITH END BRACKET |