

TMR 3 Series

Application Note

DC/DC Converter 4.5 to 9Vdc, 9 to 18Vdc, 18 to 36Vdc or 36 to 75 Vdc Input
3.3 to 15Vdc Single Outputs and ± 5 to ± 15 Vdc Dual Outputs, 3W

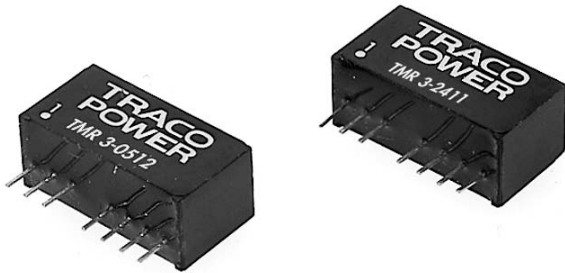

Features

- Single output current up to 700 mA
- Dual output current up to ± 300 mA
- 3 watts maximum output power
- High efficiency up to 85%
- RoHS directive compliant
- SIP package, 21.8 x 9.2 x 11.1mm (0.86 x 0.36x 0.44 inch)
- 2:1 wide input voltage range
- Low ripple & noise
- UL94-V0 case potting materials
- Input to output isolation: 1500Vdc, 1 min
- Continuous short circuit protection
- Remote ON/OFF
- ISO 9001 certified manufacturing facilities
- UL60950-1 Recognized E188913 (Pending)

Applications

- Distributed power architectures
- Workstations
- Communication equipment
- Computer equipment

Complete TMR-3 datasheet can be downloaded at:

<http://www.tracopower.com/products/tmr3.pdf>

General Description

The TMR 3 series offer 3 watts of output power from a 21.8 x 9.2 x 11.1mm package without derating up to an operating temperature of 71°C and without need of any external components. This product has a 2:1 wide input voltage of 4.5-9, 9-18, 18-36 and 36-75Vdc with an I/O isolation test voltage of 1500Vdc and indefinite short-circuit protection. All models are particularly suited to telecommunications, industrial, mobile telecom and test equipment applications.

Table of contents

Absolute Maximum Rating	P2	Remote ON/OFF Control	P73
Output Specification	P2 & P3	Mechanical Data	P74
Input Specification	P4	Recommended Pad Layout	P74
General Specification	P5	Soldering and Reflow Consideration	P75
Characteristic Curves	P6 - P69	Packaging Information	P75
Test Configurations	P70	Part Number Structure	P76
EMC Considerations	P71 - P72	Safety and Installation Instruction	P77
Input Source Impedance	P73	MTBF and Reliability	P77
Thermal Consideration	P73		

Absolute Maximum Rating				
Parameter	Model	Min	Max	Unit
Input Voltage Continuous	TMR 3-05xx TMR 3-12xx TMR 3-24xx TMR 3-48xx		9 18 36 75	Vdc
Input Voltage Transient (100ms)	TMR 3-05xx TMR 3-12xx TMR 3-24xx TMR 3-48xx		15 36 50 100	Vdc
Input Voltage Variation (complies with EST300 132 part 4.4)	All		5	V/ms
Operating Ambient Temperature (with derating)	All	-40	100	°C
Operating Case Temperature	All		100	°C
Storage Temperature	All	-55	105	°C

Output Specification					
Parameter	Model	Min	Typ	Max	Unit
Output Voltage ($V_{in} = V_{in,nom}$; Full Load ; $T_A=25^{\circ}C$)	TMR 3-xx10 TMR 3-xx11 TMR 3-xx09 TMR 3-xx12 TMR 3-xx13 TMR 3-xx21 TMR 3-xx22 TMR 3-xx23	3.267 4.95 8.91 11.88 14.85 ± 4.95 ± 11.88 ± 14.85	3.3 5 9 12 15 ± 5 ± 12 ± 15	3.333 5.05 9.09 12.12 15.15 ± 5.05 ± 12.12 ± 15.15	Vdc
Output Regulation Line ($V_{in,min}$ to $V_{in,max}$ at Full Load) Load (0% to 100% of Full Load) Load (5% to 100% of Full Load)	All	-0.2 -1.0 -0.5		+0.2 +1.0 +0.5	%
Cross Regulation Asymmetrical Load 25% / 100% of Full Load	Dual output	-5.0		+5.0	%
Output Ripple & Noise Peak-to-Peak (5Hz to 20MHz Bandwidth)	All			50	mV pk-pk
Temperature Coefficient	All	-0.1		+0.1	%/°C
Dynamic Load Response ($V_{in} = V_{in,nom}$; $T_A=25^{\circ}C$) Load step change from 75% to 100% or 100 to 75% of Full Load Setting Time ($V_{out} < 10\%$ peak deviation)	All		500		μS
Output Current	TMR 3-xx10 TMR 3-xx11 TMR 3-xx09 TMR 3-xx12 TMR 3-xx13 TMR 3-xx21 TMR 3-xx22 TMR 3-xx23	0 0 0 0 0 0 0 0		700 600 333 250 200 ± 300 ± 125 ± 100	mA
Output Short Circuit Protection	All	Continuous, automatic recovery			

Output Specification (continue)					
Parameter	Model	Min	Typ	Max	Unit
max Output Capacitor Load	TMR 3-xx10			3300	μF
	TMR 3-xx11			1680	
	TMR 3-xx09			1000	
	TMR 3-xx12			820	
	TMR 3-xx13			680	
	TMR 3-xx21			±1000	
	TMR 3-xx22			±470	
	TMR 3-xx23			±330	

Input Specification					
Parameter	Model	Min	Typ	Max	Unit
Operating Input Voltage	TMR 3-05xx	4.5	5	9	Vdc
	TMR 3-12xx	9	12	18	
	TMR 3-24xx	18	24	36	
	TMR 3-48xx	36	48	75	
Input Current (Maximum Value at $V_{in} = V_{in, nom}$; Full Load)	TMR 3-0510			650	mA
	TMR 3-0511			800	
	TMR 3-0509			789	
	TMR 3-0512			779	
	TMR 3-0513			779	
	TMR 3-0521			810	
	TMR 3-0522			779	
	TMR 3-0523			779	
	TMR 3-1210			263	
	TMR 3-1211			325	
	TMR 3-1209			329	
	TMR 3-1212			316	
	TMR 3-1213			316	
	TMR 3-1221			320	
	TMR 3-1222			316	
	TMR 3-1223			316	
	TMR 3-2410			134	
	TMR 3-2411			160	
	TMR 3-2409			160	
	TMR 3-2412			158	
	TMR 3-2413			156	
	TMR 3-2421			164	
	TMR 3-2422			158	
	TMR 3-2423			154	
	TMR 3-4810			69	
	TMR 3-4811			83	
	TMR 3-4809			82	
	TMR 3-4812			81	
	TMR 3-4813			80	
	TMR 3-4821			83	
TMR 3-4822			80		
TMR 3-4823			79		

Input Specification (continue)					
Parameter	Model	Min	Typ	Max	Unit
Input Standby Current (Typical Value at $V_{in} = V_{in,nom}$; No Load)	TMR 3-0510		45		mA
	TMR 3-0511		45		
	TMR 3-0509		55		
	TMR 3-0512		55		
	TMR 3-0513		55		
	TMR 3-0521		55		
	TMR 3-0522		60		
	TMR 3-0523		60		
	TMR 3-1210		25		
	TMR 3-1211		25		
	TMR 3-1209		30		
	TMR 3-1212		30		
	TMR 3-1213		30		
	TMR 3-1221		30		
	TMR 3-1222		30		
	TMR 3-1223		30		
	TMR 3-2410		16		
	TMR 3-2411		16		
	TMR 3-2409		17		
	TMR 3-2412		18		
	TMR 3-2413		18		
	TMR 3-2421		17		
	TMR 3-2422		18		
	TMR 3-2423		18		
	TMR 3-4810		10		
	TMR 3-4811		10		
	TMR 3-4809		11		
	TMR 3-4812		12		
	TMR 3-4813		12		
	TMR 3-4821		12		
TMR 3-4822		12			
TMR 3-4823		12			
Input Reflected Ripple Current (See Page 70)	5V INPUT			400	mA _{pk-pk}
	12V INPUT			150	
	24V INPUT			380	
	48V INPUT			170	
Start Up Time ($V_{in} = V_{in,nom}$ and constant resistive load) Power up Remote ON/OFF	All		30		mS
			30		
Remote ON/OFF Control (See Page 73) DC-DC ON DC-DC OFF	All	2	Open	4	mA
			3		
Remote Off Input Current	All			2.5	mA

General Specification					
Parameter	Model	Min	Typ	Max	Unit
Efficiency (See Page 52) ($V_{in} = V_{innom}$; Full Load ; $T_A=25^{\circ}C$)	TMR 3-0510		75		%
	TMR 3-0511		79		
	TMR 3-0509		80		
	TMR 3-0512		81		
	TMR 3-0513		82		
	TMR 3-0521		78		
	TMR 3-0522		81		
	TMR 3-0523		81		
	TMR 3-1210		77		
	TMR 3-1211		81		
	TMR 3-1209		80		
	TMR 3-1212		83		
	TMR 3-1213		83		
	TMR 3-1221		82		
	TMR 3-1222		83		
	TMR 3-1223		83		
	TMR 3-2410		76		
	TMR 3-2411		82		
	TMR 3-2409		82		
	TMR 3-2412		83		
	TMR 3-2413		84		
	TMR 3-2421		80		
	TMR 3-2422		83		
	TMR 3-2423		85		
	TMR 3-4810		74		
	TMR 3-4811		79		
	TMR 3-4809		80		
	TMR 3-4812		81		
	TMR 3-4813		82		
	TMR 3-4821		79		
TMR 3-4822		82			
TMR 3-4823		83			
Isolation Voltage (functional Insulation; 60 seconds) Input to Output	All	1600			Vdc
Isolation Resistance	All	1			GΩ
Isolation Capacitance	All			200	pF
Switching Frequency	All	100			KHz
Weight	All		4.8		g
MTBF (See Page 53) Bellcore TR-NWT-000332, TC=40 °C MIL-STD-217F	All		4.386×10 ⁶ 2.401×10 ⁶		hours

Characteristic Curves

All test conditions are at 25°C. The figures are identical for TMR 3-0510

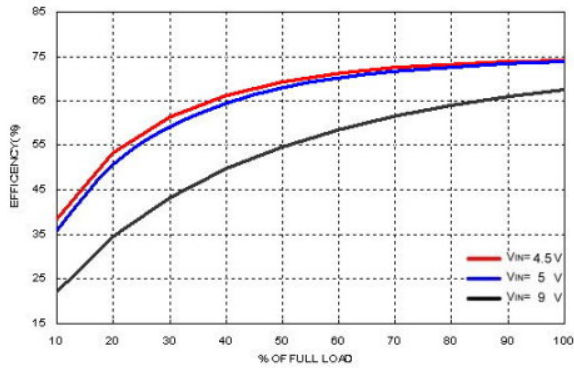

Efficiency versus Output Current

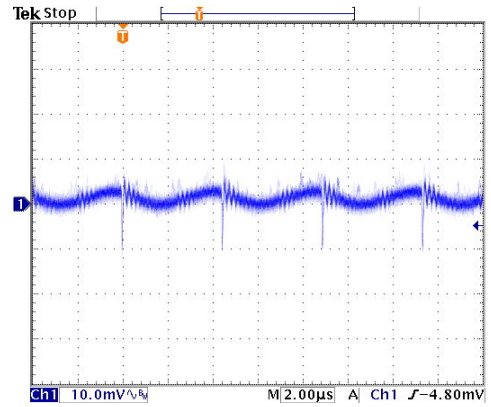

Typical Output Ripple and Noise.

$V_{in} = V_{in,nom}$, Full Load

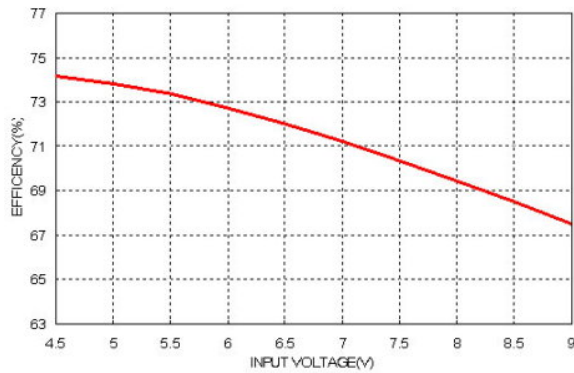

Efficiency versus Input Voltage. Full Load

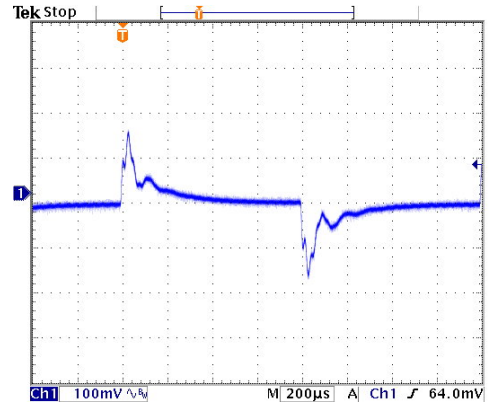

Transient Response to Dynamic Load Change from

100% to 75% to 100% of Full Load ; $V_{in} = V_{in,nom}$

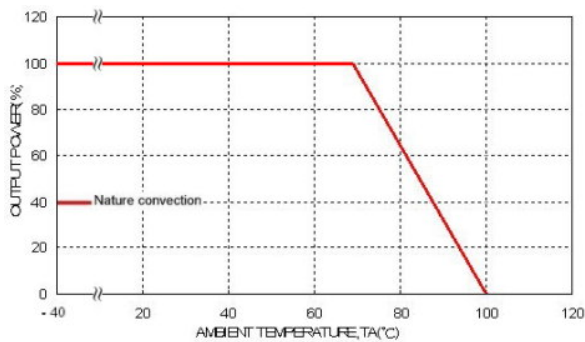

Derating Output Current versus Ambient Temperature and Airflow $V_{in} = V_{in,nom}$

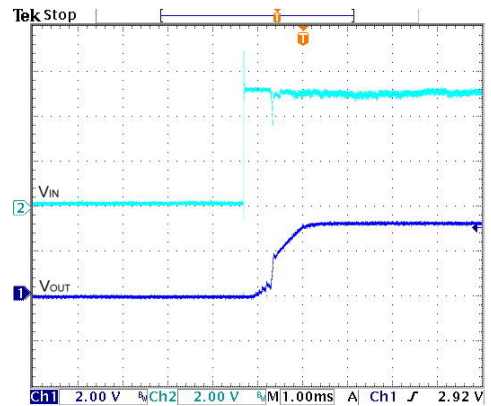

Typical Input Start-Up and Output Rise Characteristic

$V_{in} = V_{in,nom}$, Full Load

Characteristic Curves

All test conditions are at 25°C. The figures are identical for TMR 3-0510 (Continued)

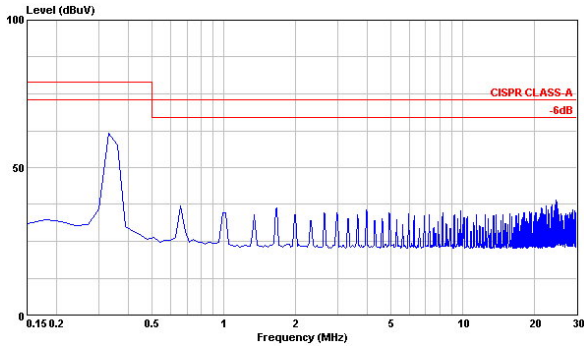

Conduction Emission of EN55022 Class A
 $V_{in} = V_{in,nom}$, Full Load

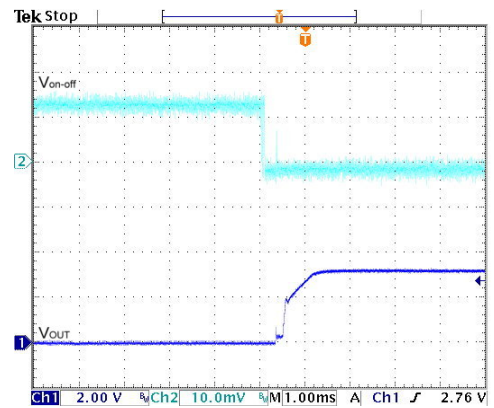

Using ON/OFF Voltage Start-Up and V_{out} Rise Characteristic
 $V_{in} = V_{in,nom}$, Full Load

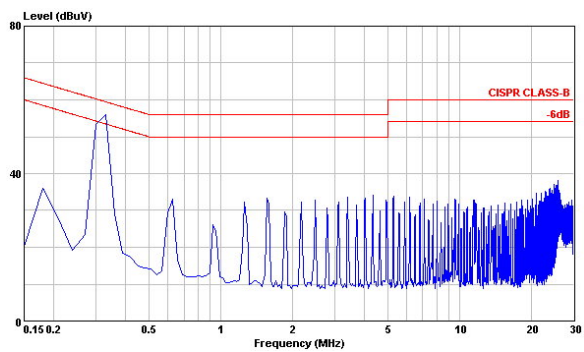

Conduction Emission of EN55022 Class B
 $V_{in} = V_{in,nom}$, Full Load

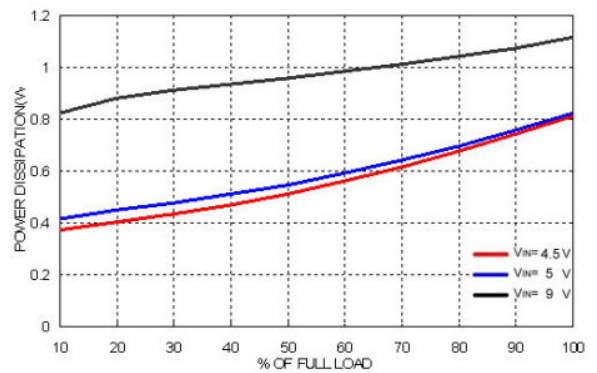

Power Dissipation versus Output Current

Characteristic Curves

All test conditions are at 25°C. The figures are identical for TMR 3-0511

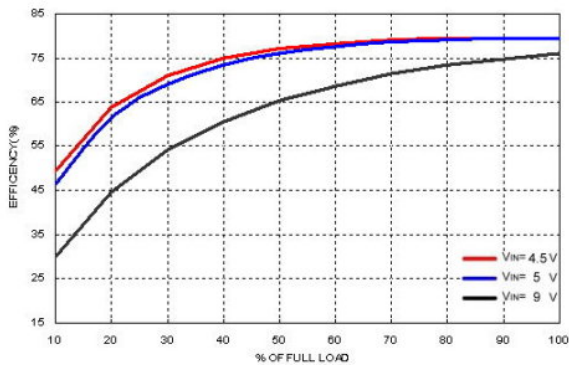

Efficiency versus Output Current

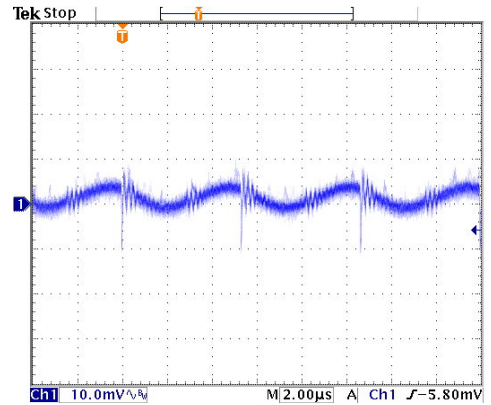

Typical Output Ripple and Noise.

$V_{in} = V_{in,nom}$, Full Load

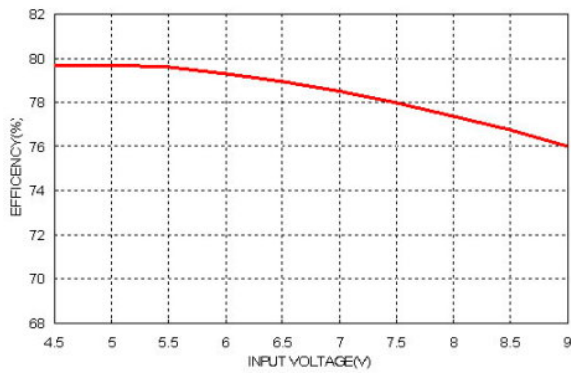

Efficiency versus Input Voltage. Full Load

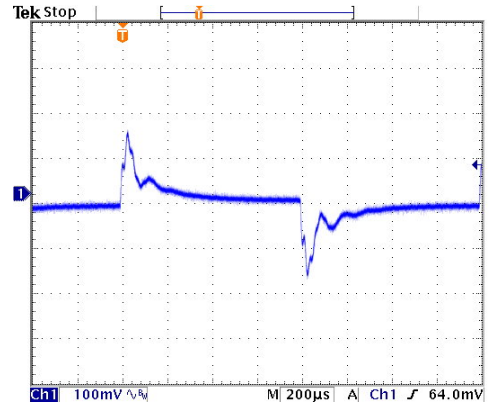

Transient Response to Dynamic Load Change from

100% to 75% to 100% of Full Load ; $V_{in} = V_{in,nom}$

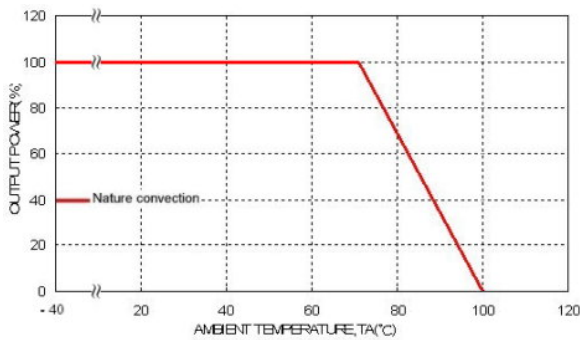

Derating Output Current versus Ambient Temperature and Airflow $V_{in} = V_{in,nom}$

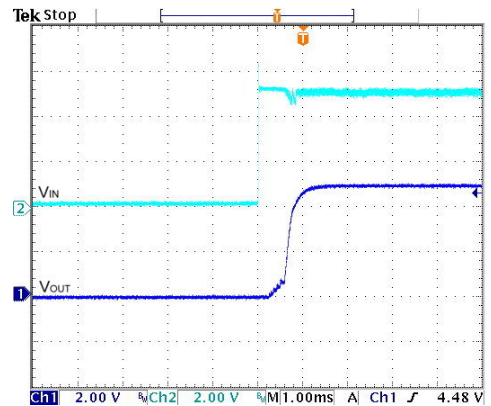

Typical Input Start-Up and Output Rise Characteristic

$V_{in} = V_{in,nom}$, Full Load

Characteristic Curves

All test conditions are at 25°C. The figures are identical for TMR 3-0511 (Continued)

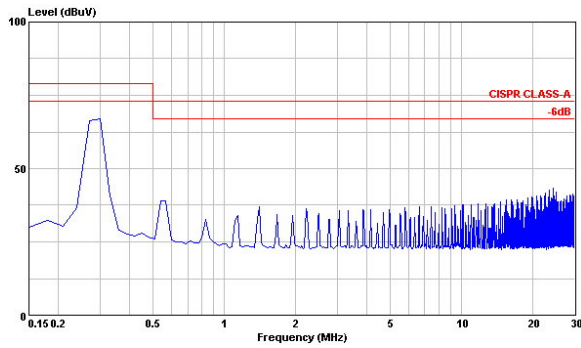

Conduction Emission of EN55022 Class A
 $V_{in} = V_{in,nom}$, Full Load

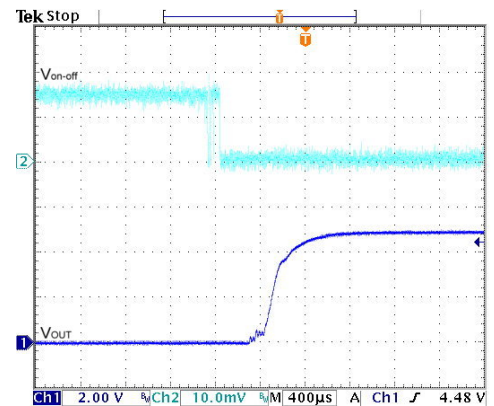

Using ON/OFF Voltage Start-Up and V_{out} Rise Characteristic
 $V_{in} = V_{in,nom}$, Full Load

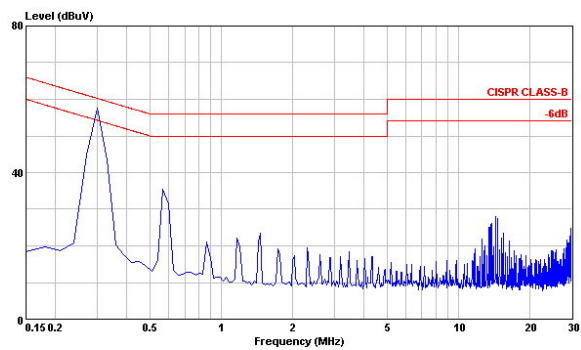

Conduction Emission of EN55022 Class B
 $V_{in} = V_{in,nom}$, Full Load

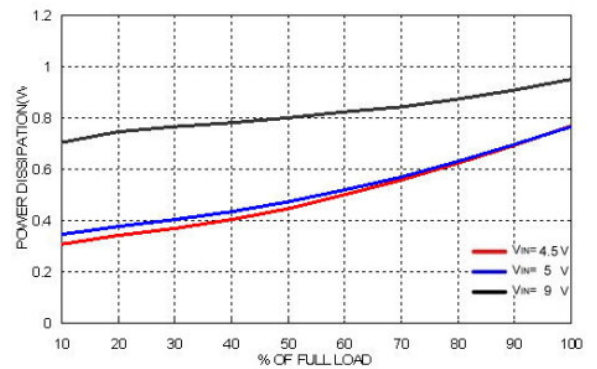

Power Dissipation versus Output Current

Characteristic Curves

All test conditions are at 25°C. The figures are identical for TMR 3-0509

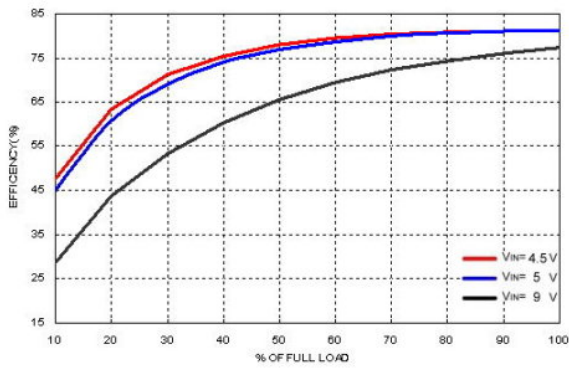

Efficiency versus Output Current

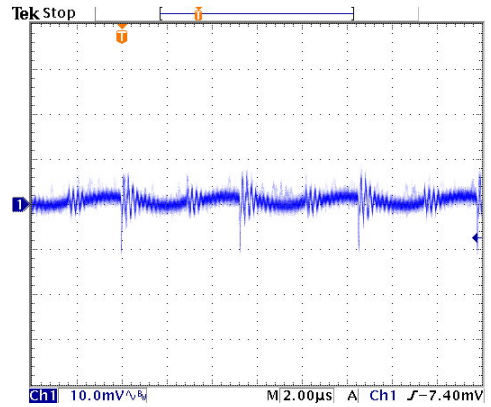

Typical Output Ripple and Noise.

$V_{in} = V_{in,nom}$, Full Load

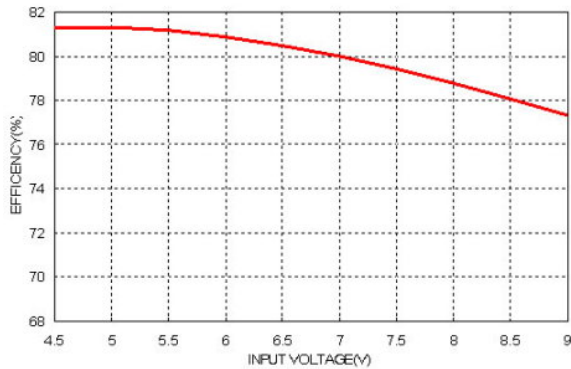

Efficiency versus Input Voltage. Full Load

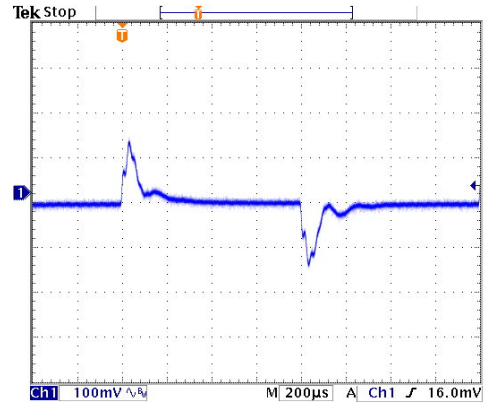

Transient Response to Dynamic Load Change from 100% to 75% to 100% of Full Load ; $V_{in} = V_{in,nom}$

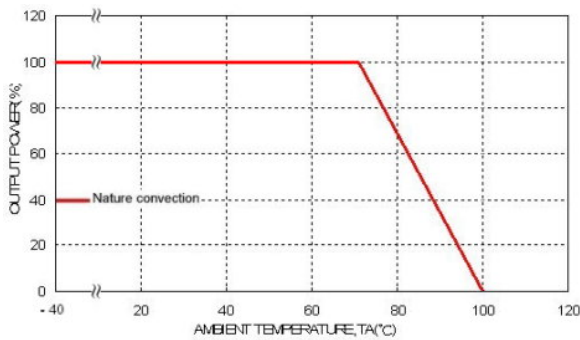

Derating Output Current versus Ambient Temperature and Airflow $V_{in} = V_{in,nom}$

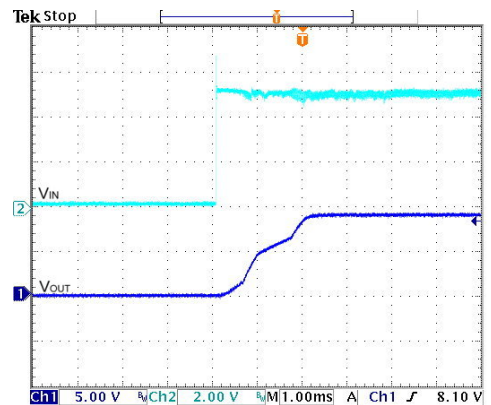

Typical Input Start-Up and Output Rise Characteristic

$V_{in} = V_{in,nom}$, Full Load

Characteristic Curves

All test conditions are at 25°C. The figures are identical for TMR 3-0509 (Continued)

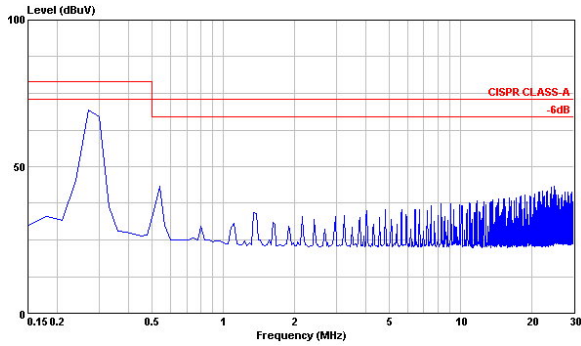

Conduction Emission of EN55022 Class A
 $V_{in} = V_{in,nom}$, Full Load

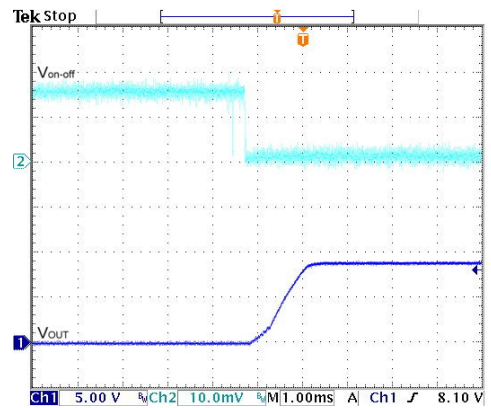

Using ON/OFF Voltage Start-Up and V_{out} Rise Characteristic
 $V_{in} = V_{in,nom}$, Full Load

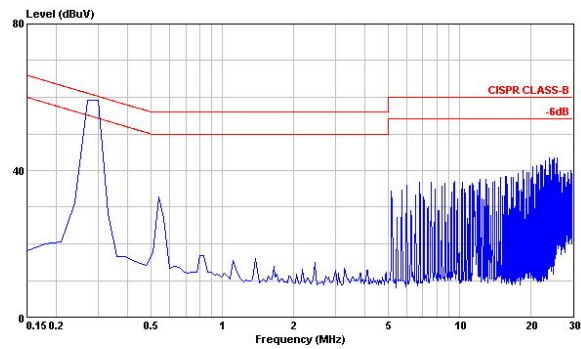

Conduction Emission of EN55022 Class B
 $V_{in} = V_{in,nom}$, Full Load

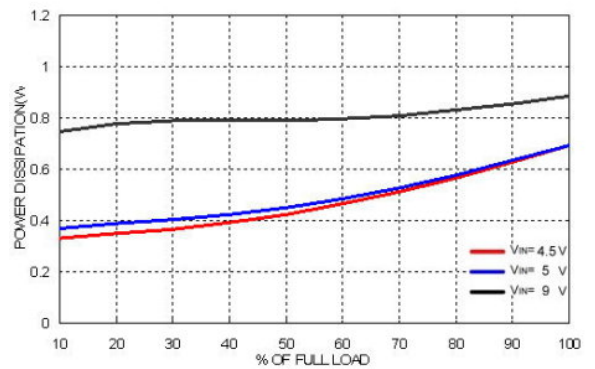

Power Dissipation versus Output Current

Characteristic Curves

All test conditions are at 25°C. The figures are identical for TMR 3-0512

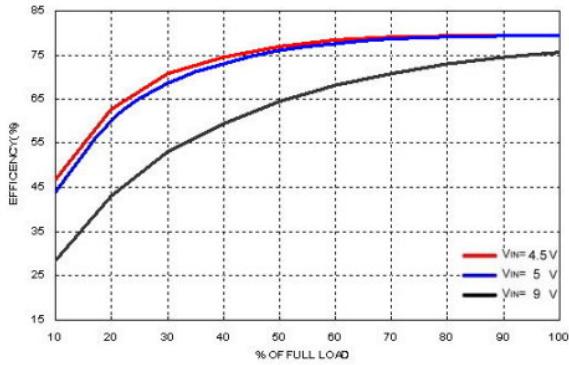

Efficiency versus Output Current

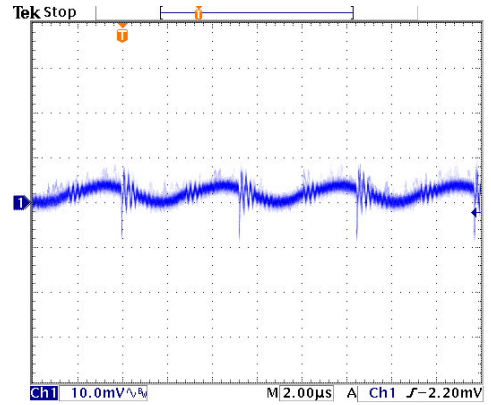

Typical Output Ripple and Noise.

$V_{in} = V_{in,nom}$, Full Load

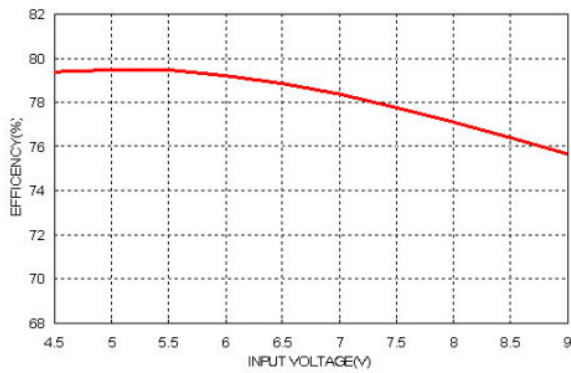

Efficiency versus Input Voltage. Full Load

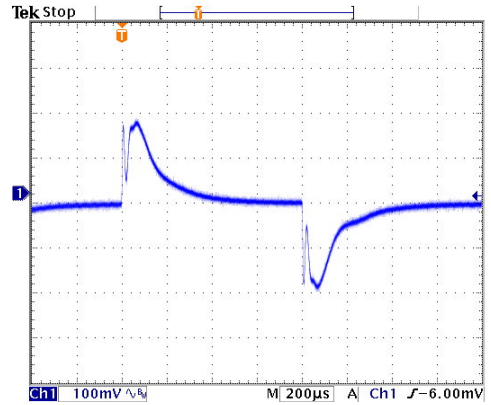

Transient Response to Dynamic Load Change from 100% to 75% to 100% of Full Load ; $V_{in} = V_{in,nom}$

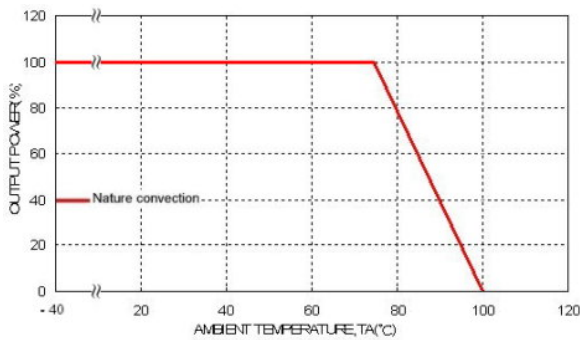

Derating Output Current versus Ambient Temperature and Airflow $V_{in} = V_{in,nom}$

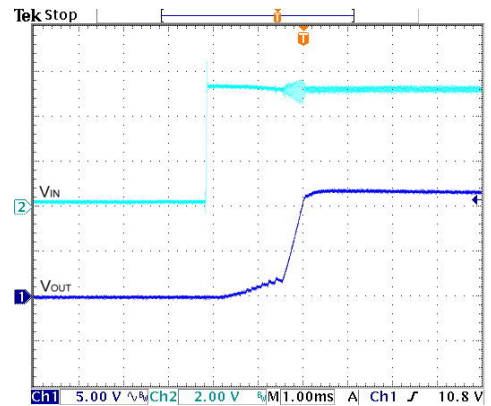

Typical Input Start-Up and Output Rise Characteristic

$V_{in} = V_{in,nom}$, Full Load

Characteristic Curves

All test conditions are at 25°C. The figures are identical for TMR 3-0512 (Continued)

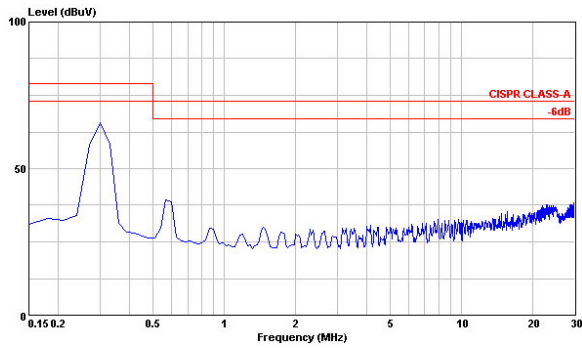

Conduction Emission of EN55022 Class A

$V_{in} = V_{in,nom}$, Full Load

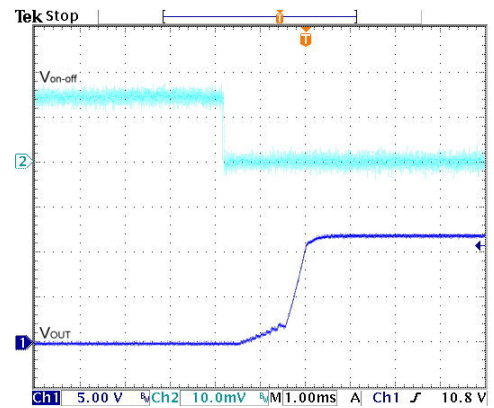

Using ON/OFF Voltage Start-Up and V_{out} Rise Characteristic

$V_{in} = V_{in,nom}$, Full Load

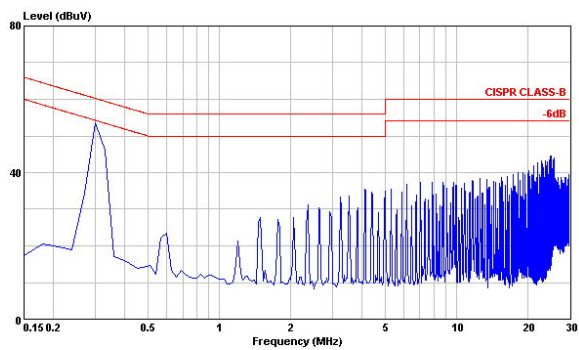

Conduction Emission of EN55022 Class B

$V_{in} = V_{in,nom}$, Full Load

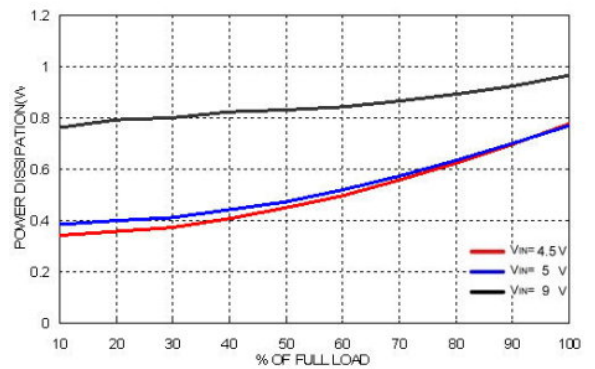

Power Dissipation versus Output Current

Characteristic Curves

All test conditions are at 25°C. The figures are identical for TMR 3-0513

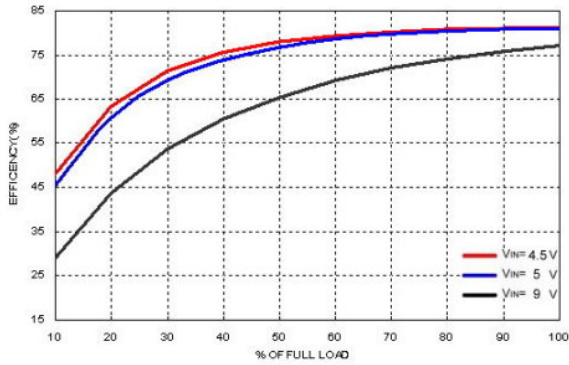

Efficiency versus Output Current

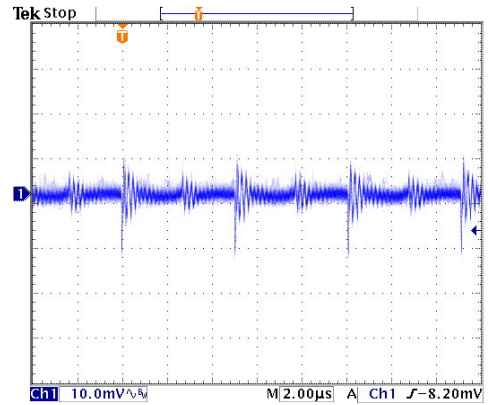

Typical Output Ripple and Noise.

$V_{in} = V_{in,nom}$, Full Load

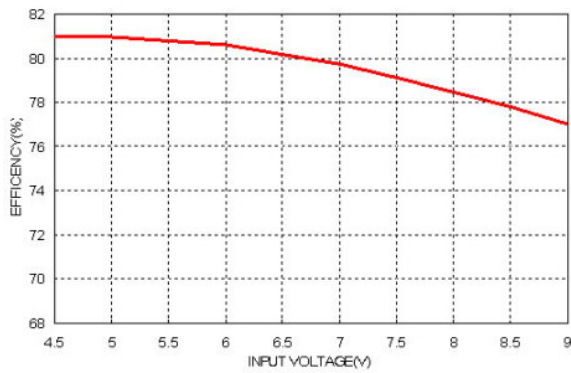

Efficiency versus Input Voltage. Full Load

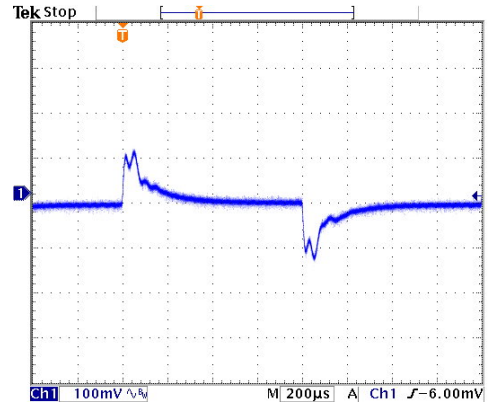

Transient Response to Dynamic Load Change from

100% to 75% to 100% of Full Load ; $V_{in} = V_{in,nom}$

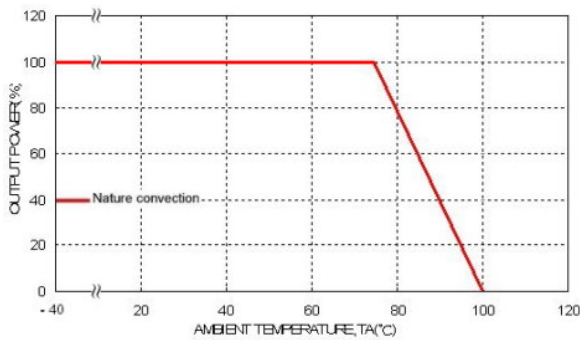

Derating Output Current versus Ambient Temperature and Airflow $V_{in} = V_{in,nom}$

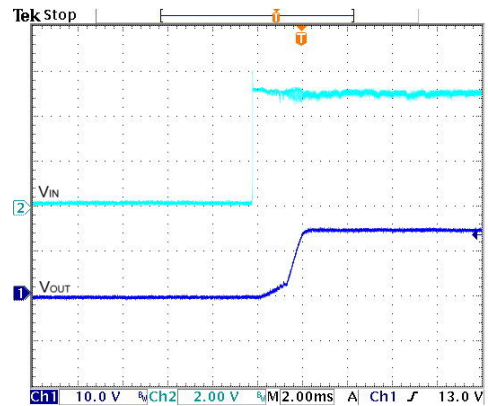

Typical Input Start-Up and Output Rise Characteristic

$V_{in} = V_{in,nom}$, Full Load

Characteristic Curves

All test conditions are at 25°C. The figures are identical for TMR 3-0513 (Continued)

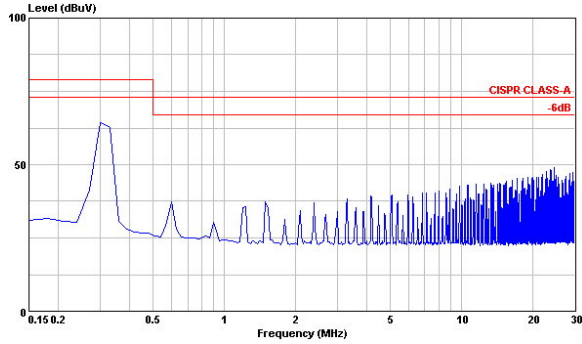

Conduction Emission of EN55022 Class A

$V_{in} = V_{in,nom}$, Full Load

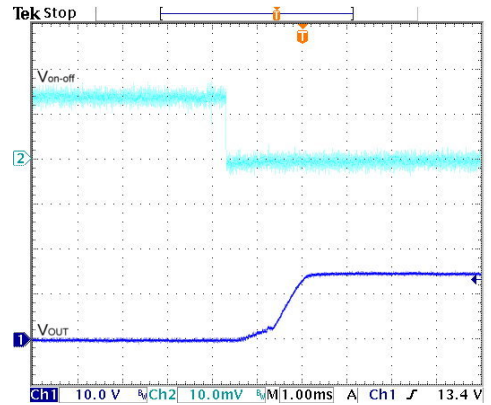

Using ON/OFF Voltage Start-Up and V_{out} Rise Characteristic

$V_{in} = V_{in,nom}$, Full Load

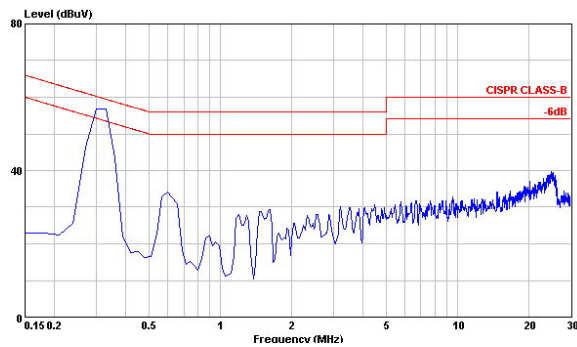

Conduction Emission of EN55022 Class B

$V_{in} = V_{in,nom}$, Full Load

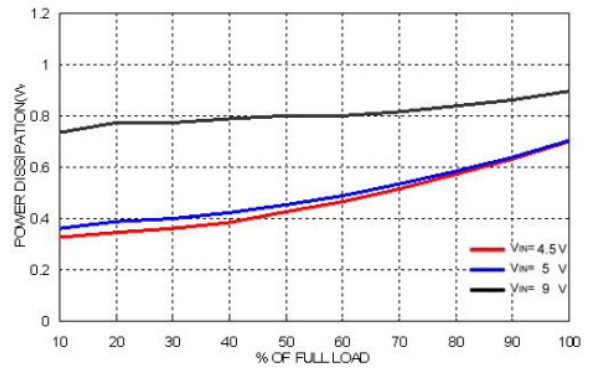

Power Dissipation versus Output Current

Characteristic Curves

All test conditions are at 25°C. The figures are identical for TMR 3-0521

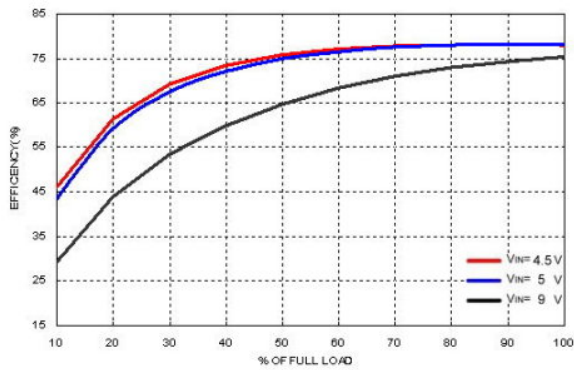

Efficiency versus Output Current

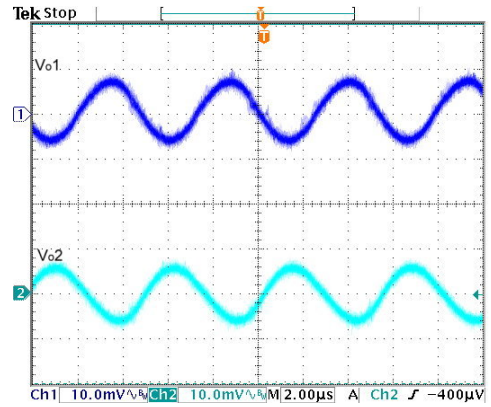

Typical Output Ripple and Noise.

$V_{in} = V_{in,nom}$, Full Load

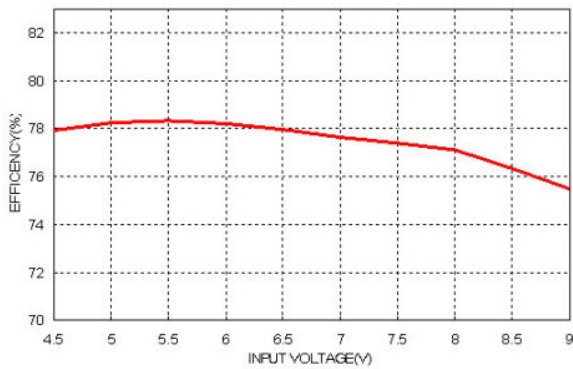

Efficiency versus Input Voltage, Full Load

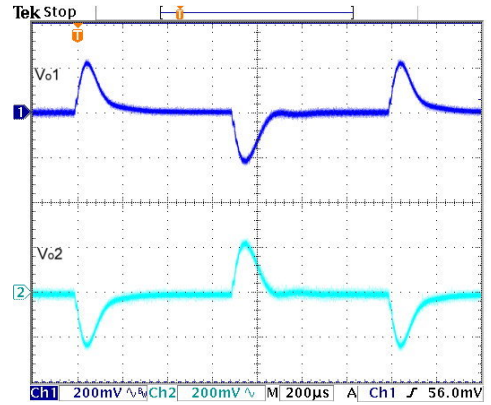

Transient Response to Dynamic Load Change from 100% to 75% to 100% of Full Load ; $V_{in} = V_{in,nom}$

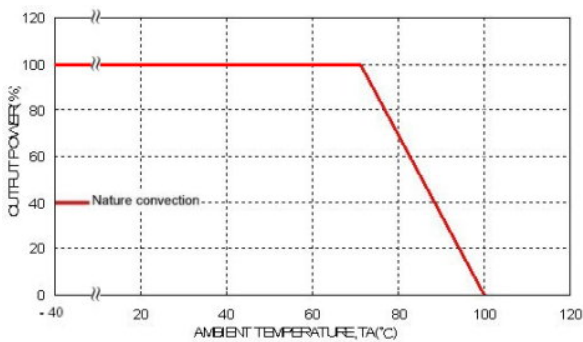

Derating Output Current versus Ambient Temperature and Airflow $V_{in} = V_{in,nom}$

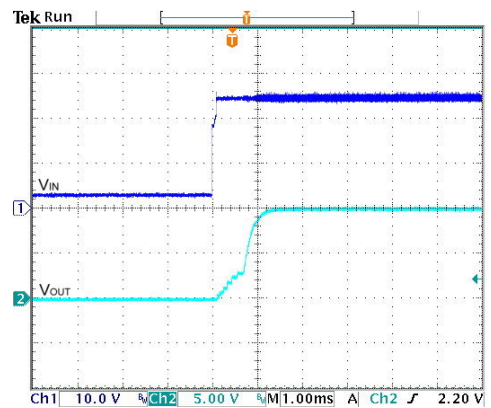

Typical Input Start-Up and Output Rise Characteristic

$V_{in} = V_{in,nom}$, Full Load

Characteristic Curves

All test conditions are at 25°C. The figures are identical for TMR 3-0521 (Continued)

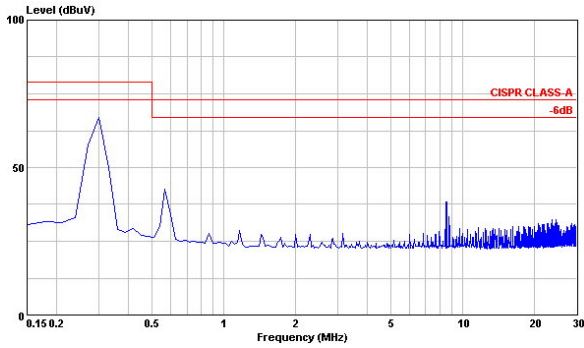

Conduction Emission of EN55022 Class A

$V_{in} = V_{in,nom}$, Full Load

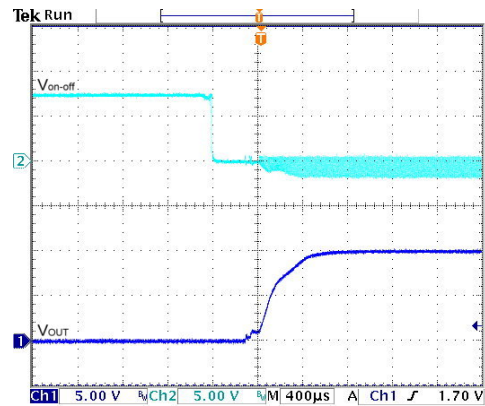

Using ON/OFF Voltage Start-Up and V_{out} Rise Characteristic

$V_{in} = V_{in,nom}$, Full Load

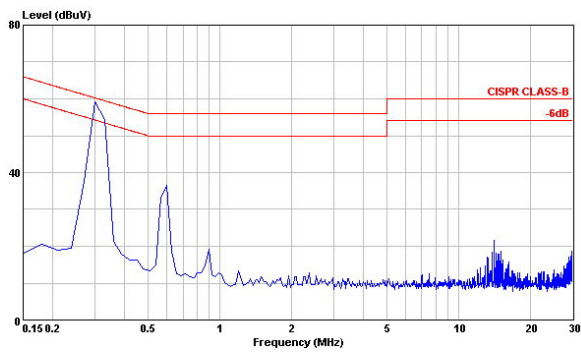

Conduction Emission of EN55022 Class B

$V_{in} = V_{in,nom}$, Full Load

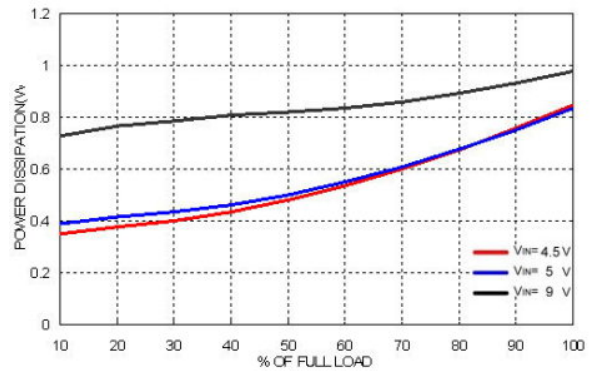

Power Dissipation versus Output Current

Characteristic Curves

All test conditions are at 25°C. The figures are identical for TMR 3-0522

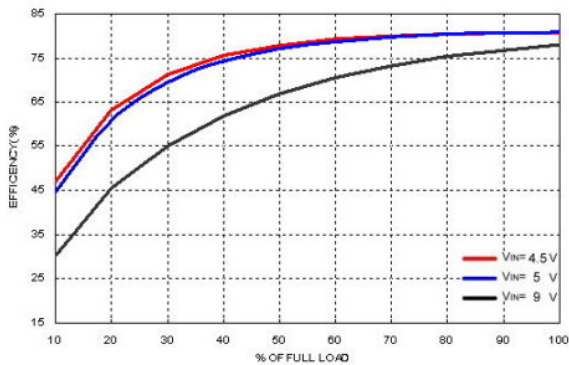

Efficiency versus Output Current

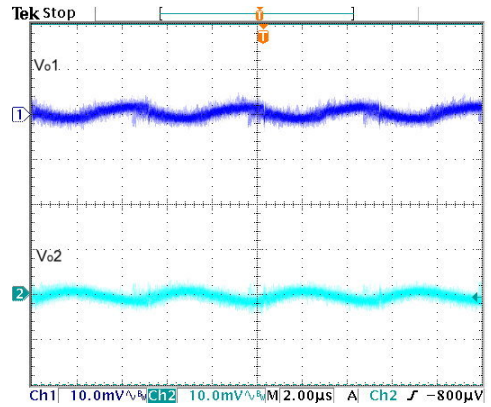

Typical Output Ripple and Noise.

$V_{in} = V_{in,nom}$, Full Load

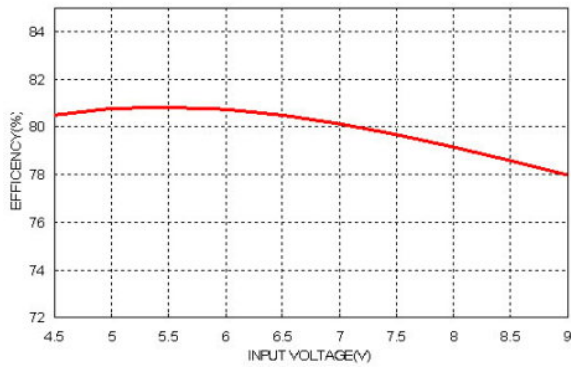

Efficiency versus Input Voltage. Full Load

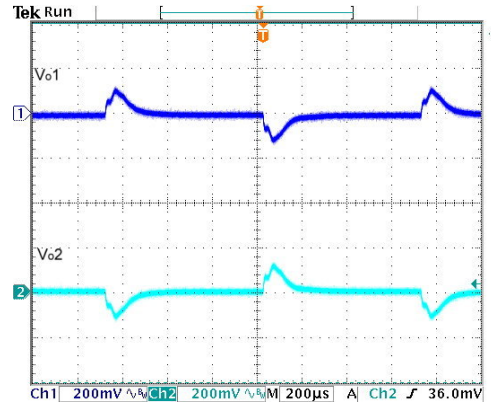

Transient Response to Dynamic Load Change from 100% to 75% to 100% of Full Load ; $V_{in} = V_{in,nom}$

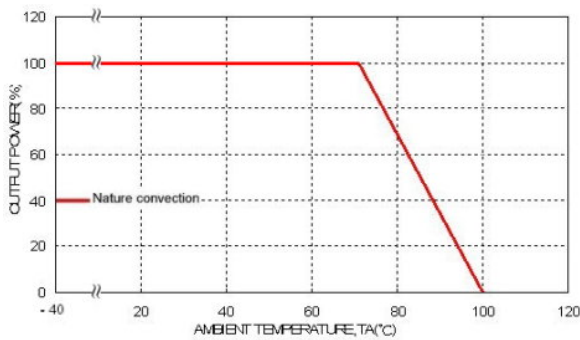

Derating Output Current versus Ambient Temperature and Airflow $V_{in} = V_{in,nom}$

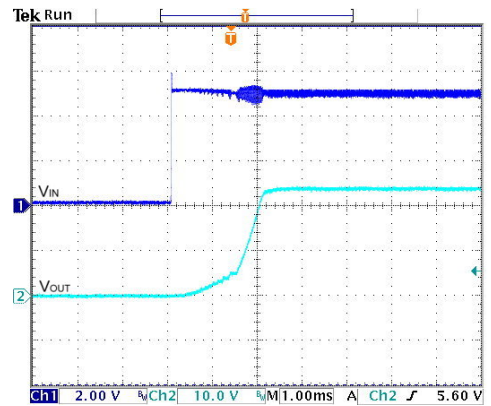

Typical Input Start-Up and Output Rise Characteristic

$V_{in} = V_{in,nom}$, Full Load

Characteristic Curves

All test conditions are at 25°C. The figures are identical for TMR 3-0522 (Continued)

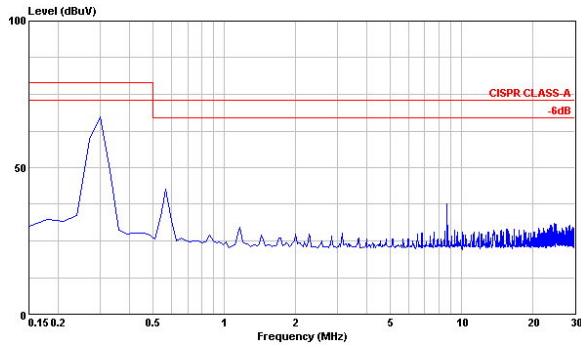

Conduction Emission of EN55022 Class A
 $V_{in} = V_{in,nom}$, Full Load

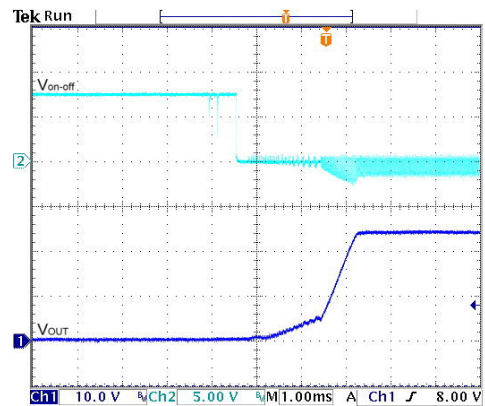

Using ON/OFF Voltage Start-Up and V_{out} Rise Characteristic
 $V_{in} = V_{in,nom}$, Full Load

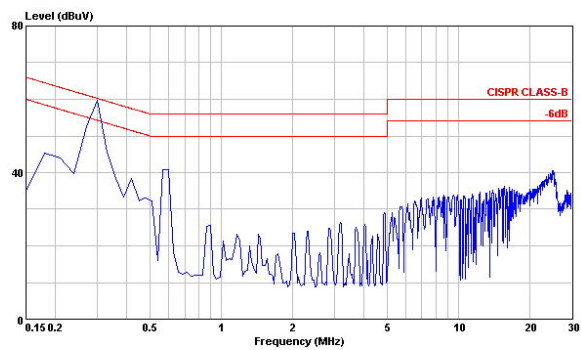

Conduction Emission of EN55022 Class B
 $V_{in} = V_{in,nom}$, Full Load

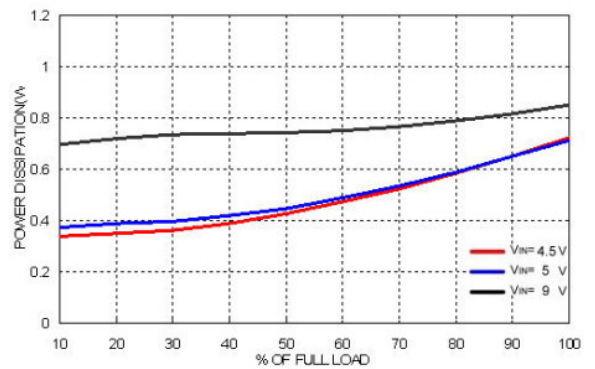

Power Dissipation versus Output Current

Characteristic Curves

All test conditions are at 25°C. The figures are identical for TMR 3-0523

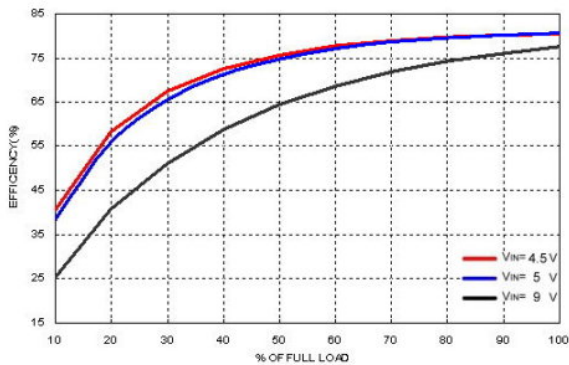

Efficiency versus Output Current

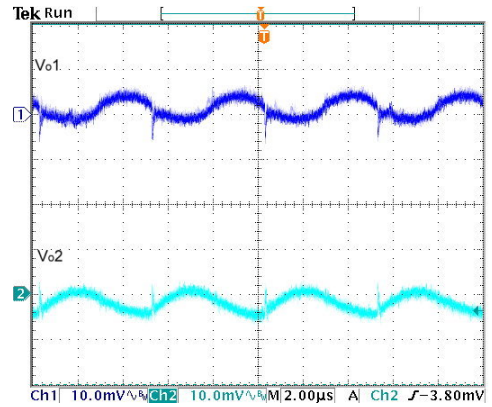

Typical Output Ripple and Noise.

$V_{in} = V_{in,nom}$, Full Load

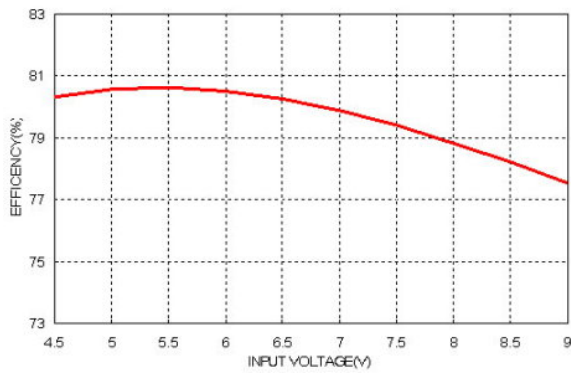

Efficiency versus Input Voltage. Full Load

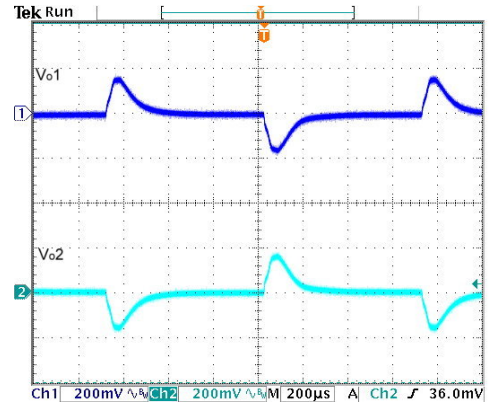

Transient Response to Dynamic Load Change from

100% to 75% to 100% of Full Load ; $V_{in} = V_{in,nom}$

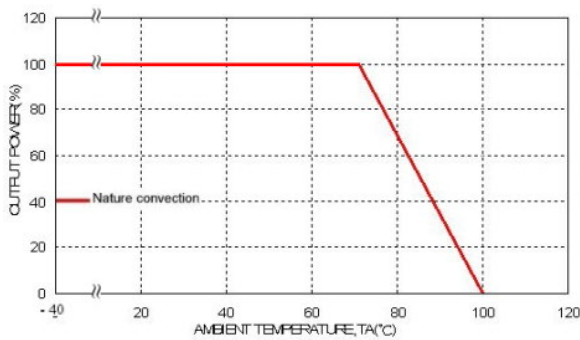

Derating Output Current versus Ambient Temperature and Airflow $V_{in} = V_{in,nom}$

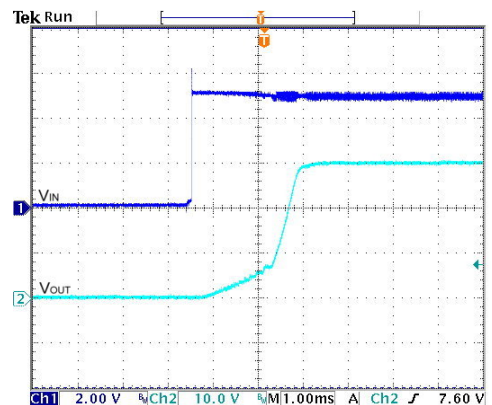

Typical Input Start-Up and Output Rise Characteristic

$V_{in} = V_{in,nom}$, Full Load

Characteristic Curves

All test conditions are at 25°C. The figures are identical for TMR 3-0523 (Continued)

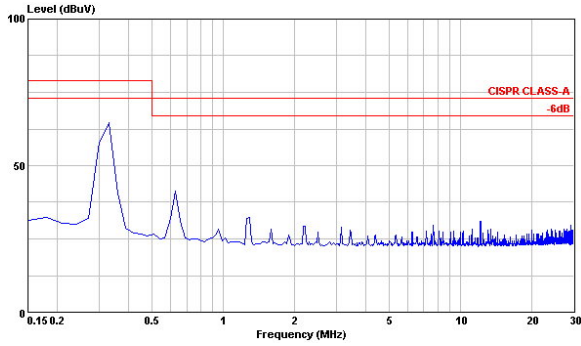

Conduction Emission of EN55022 Class A

$V_{in} = V_{in,nom}$, Full Load

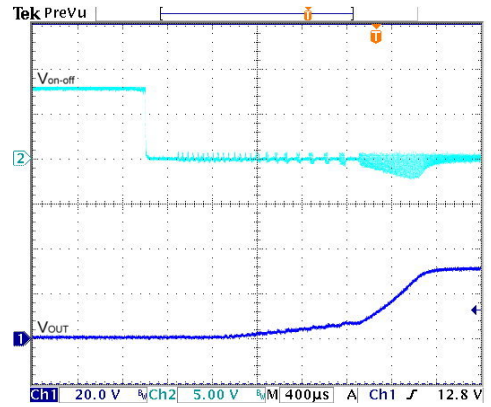

Using ON/OFF Voltage Start-Up and V_{out} Rise Characteristic

$V_{in} = V_{in,nom}$, Full Load

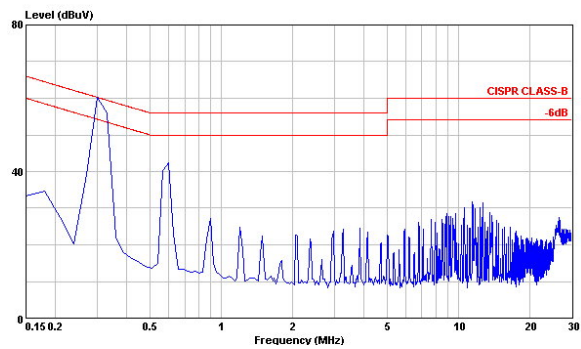

Conduction Emission of EN55022 Class B

$V_{in} = V_{in,nom}$, Full Load

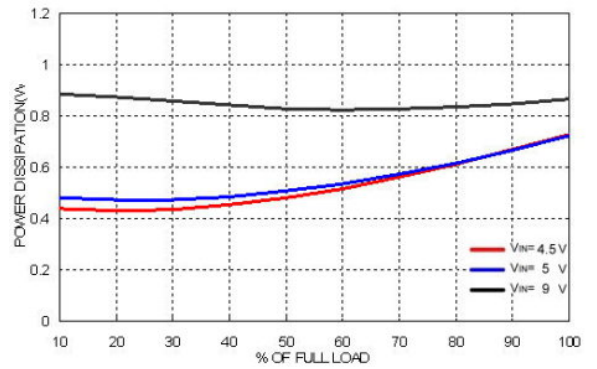

Power Dissipation versus Output Current

Characteristic Curves

All test conditions are at 25°C. The figures are identical for TMR 3-1210

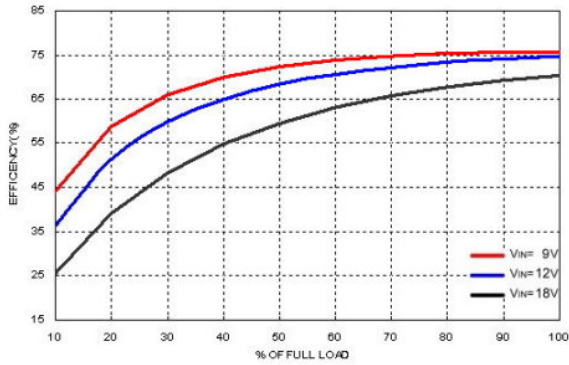

Efficiency versus Output Current

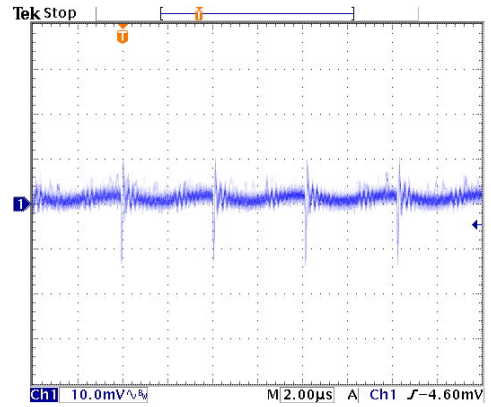

Typical Output Ripple and Noise.

$V_{in} = V_{in,nom}$, Full Load

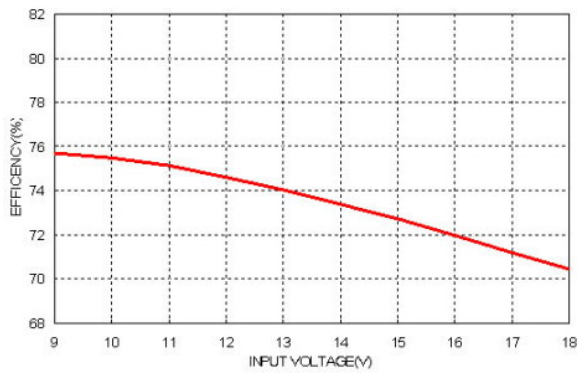

Efficiency versus Input Voltage. Full Load

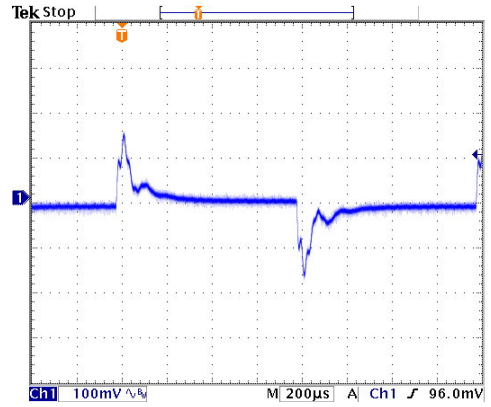

Transient Response to Dynamic Load Change from

100% to 75% to 100% of Full Load ; $V_{in} = V_{in,nom}$

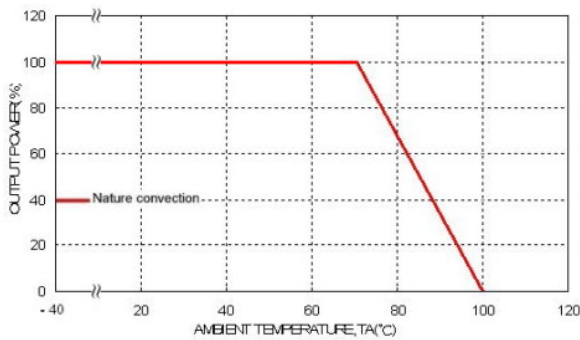

Derating Output Current versus Ambient Temperature and Airflow $V_{in} = V_{in,nom}$

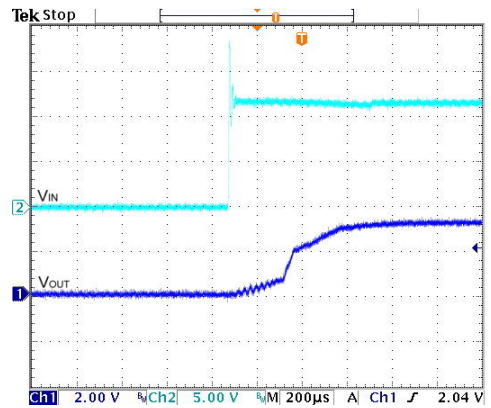

Typical Input Start-Up and Output Rise Characteristic

$V_{in} = V_{in,nom}$, Full Load

Characteristic Curves

All test conditions are at 25°C. The figures are identical for TMR 3-1210 (Continued)

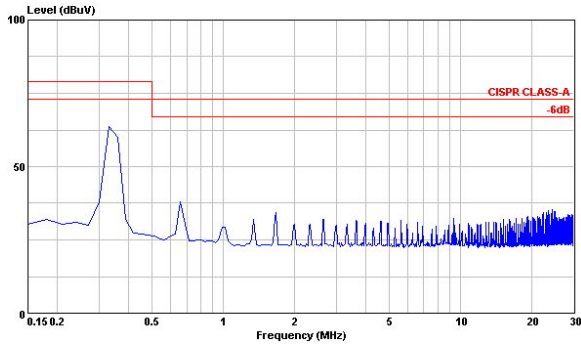

Conduction Emission of EN55022 Class A

$V_{in} = V_{in,nom}$, Full Load

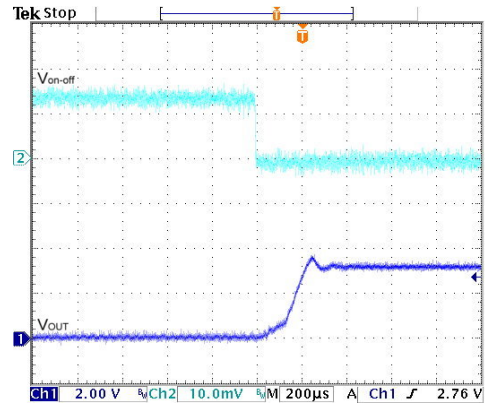

Using ON/OFF Voltage Start-Up and V_{out} Rise Characteristic

$V_{in} = V_{in,nom}$, Full Load

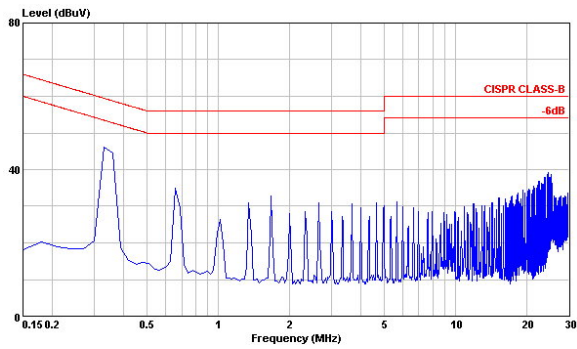

Conduction Emission of EN55022 Class B

$V_{in} = V_{in,nom}$, Full Load

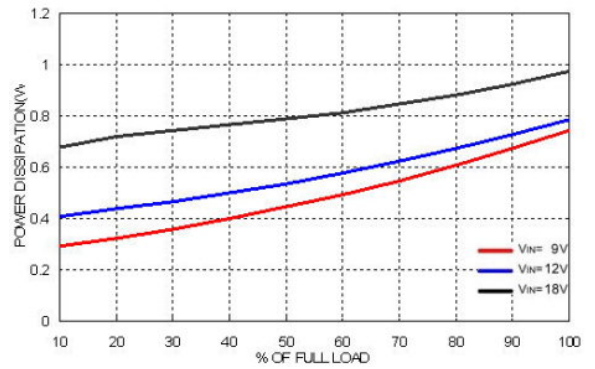

Power Dissipation versus Output Current

Characteristic Curves

All test conditions are at 25°C. The figures are identical for TMR 3-1211

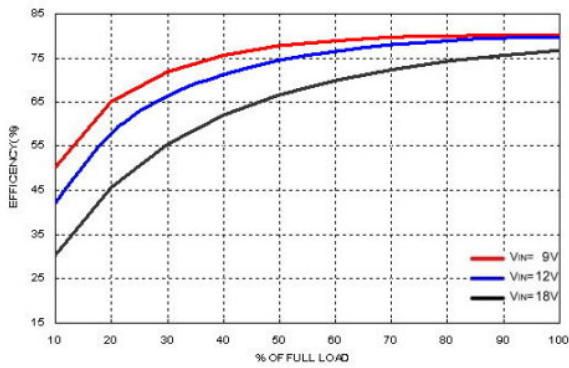

Efficiency versus Output Current

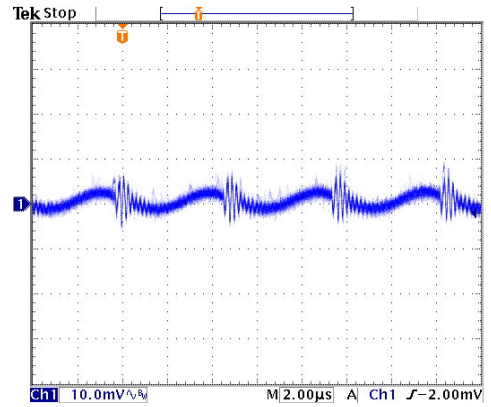

Typical Output Ripple and Noise.

$V_{in} = V_{in,nom}$, Full Load

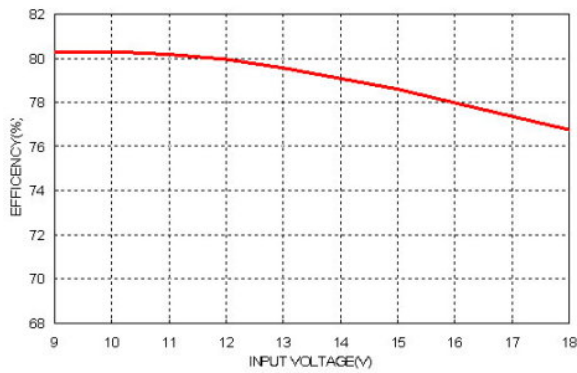

Efficiency versus Input Voltage. Full Load

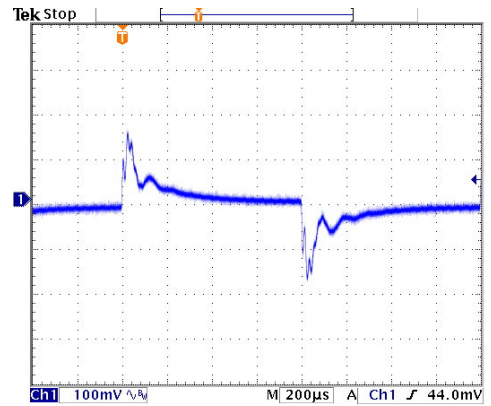

Transient Response to Dynamic Load Change from 100% to 75% to 100% of Full Load ; $V_{in} = V_{in,nom}$

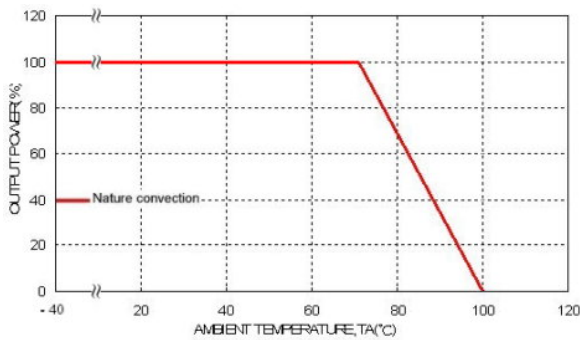

Derating Output Current versus Ambient Temperature and Airflow $V_{in} = V_{in,nom}$

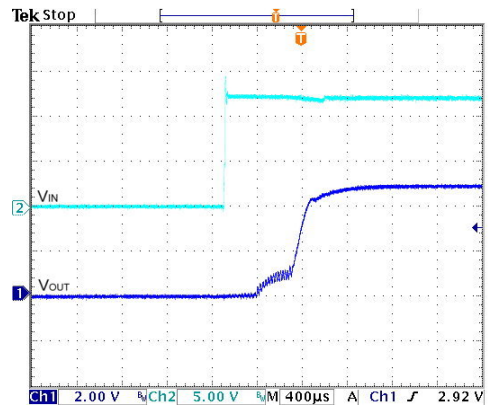

Typical Input Start-Up and Output Rise Characteristic

$V_{in} = V_{in,nom}$, Full Load

Characteristic Curves

All test conditions are at 25°C. The figures are identical for TMR 3-1211 (Continued)

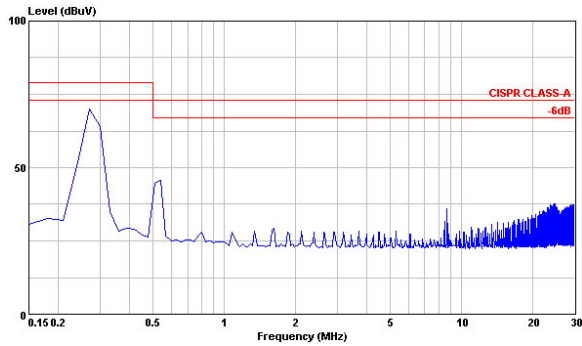

Conduction Emission of EN55022 Class A

$V_{in} = V_{in,nom}$, Full Load

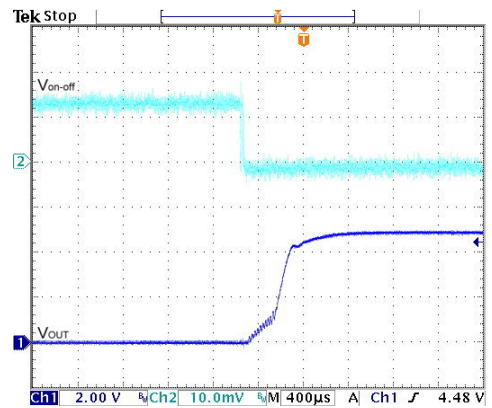

Using ON/OFF Voltage Start-Up and V_{out} Rise Characteristic

$V_{in} = V_{in,nom}$, Full Load

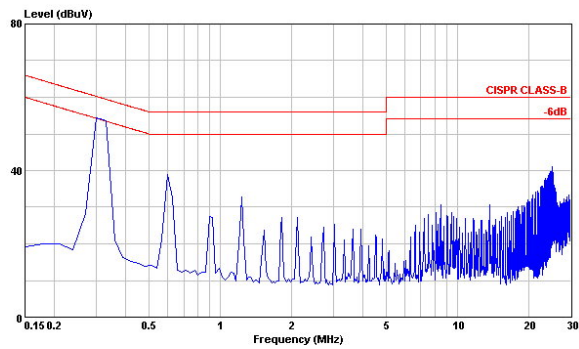

Conduction Emission of EN55022 Class B

$V_{in} = V_{in,nom}$, Full Load

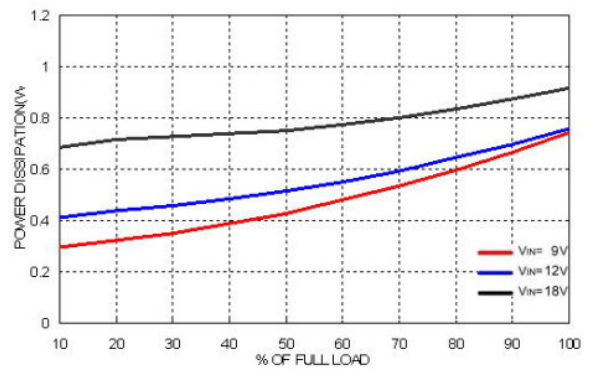

Power Dissipation versus Output Current

Characteristic Curves

All test conditions are at 25°C. The figures are identical for TMR 3-1209

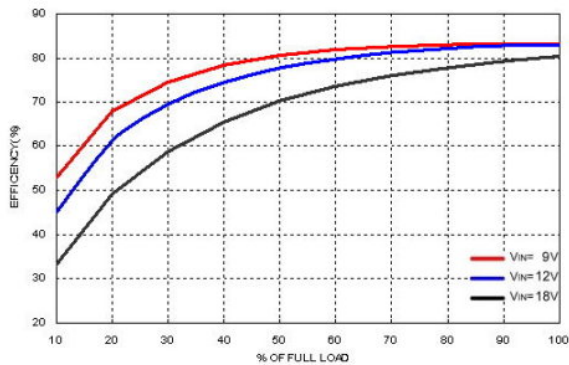

Efficiency versus Output Current

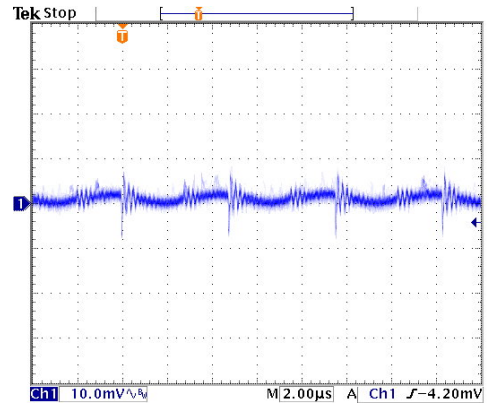

Typical Output Ripple and Noise.

$V_{in} = V_{in,nom}$, Full Load

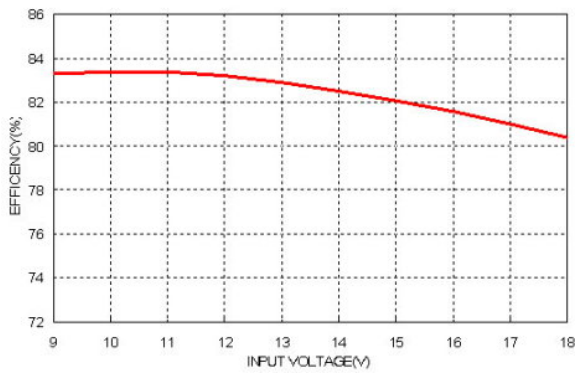

Efficiency versus Input Voltage. Full Load

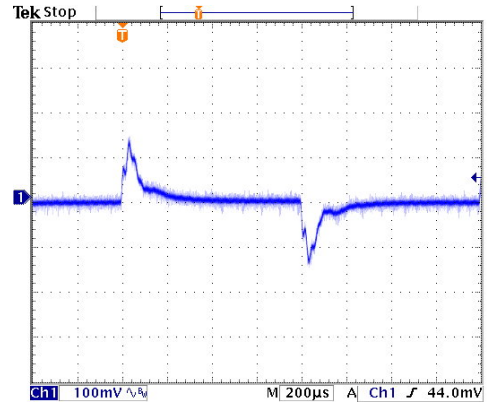

Transient Response to Dynamic Load Change from

100% to 75% to 100% of Full Load ; $V_{in} = V_{in,nom}$

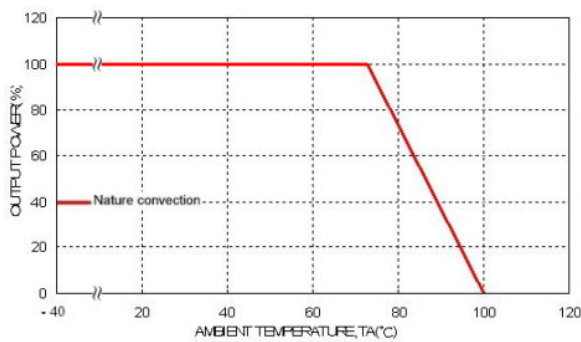

Derating Output Current versus Ambient Temperature and Airflow $V_{in} = V_{in,nom}$

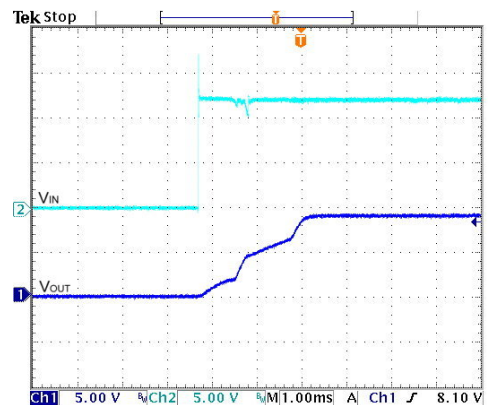

Typical Input Start-Up and Output Rise Characteristic

$V_{in} = V_{in,nom}$, Full Load

Characteristic Curves

All test conditions are at 25°C. The figures are identical for TMR 3-1209 (Continued)

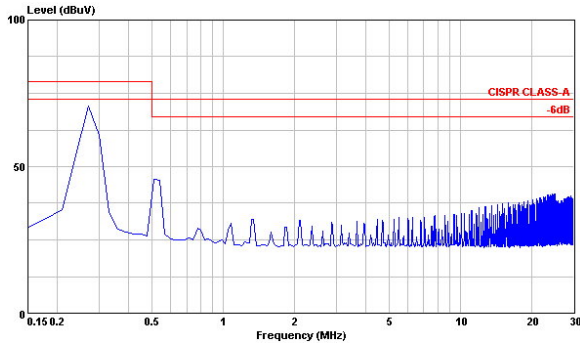

Conduction Emission of EN55022 Class A
 $V_{in} = V_{in,nom}$, Full Load

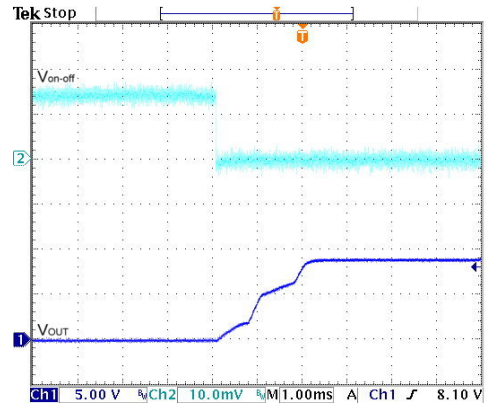

Using ON/OFF Voltage Start-Up and V_{out} Rise Characteristic
 $V_{in} = V_{in,nom}$, Full Load

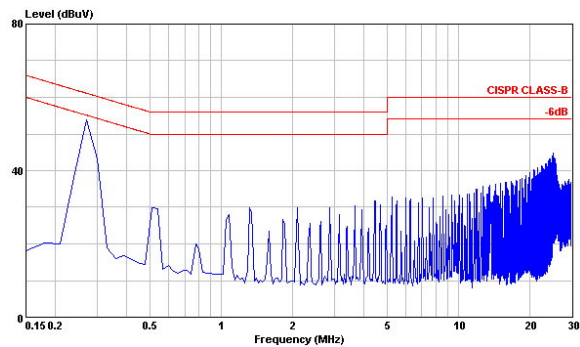

Conduction Emission of EN55022 Class B
 $V_{in} = V_{in,nom}$, Full Load

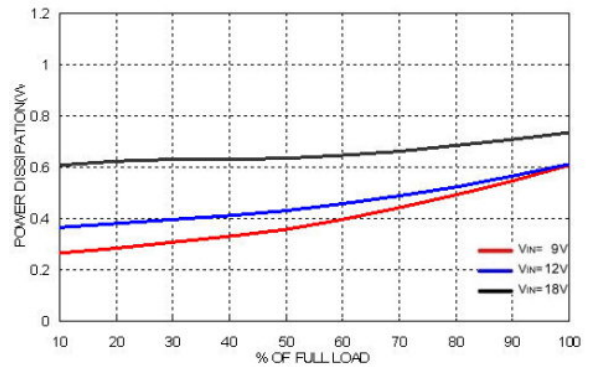

Power Dissipation versus Output Current

Characteristic Curves

All test conditions are at 25°C. The figures are identical for TMR 3-1212

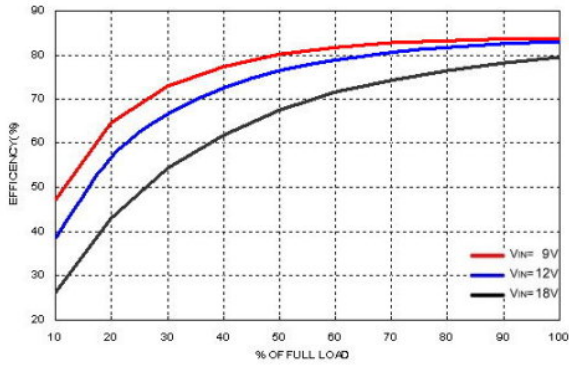

Efficiency versus Output Current

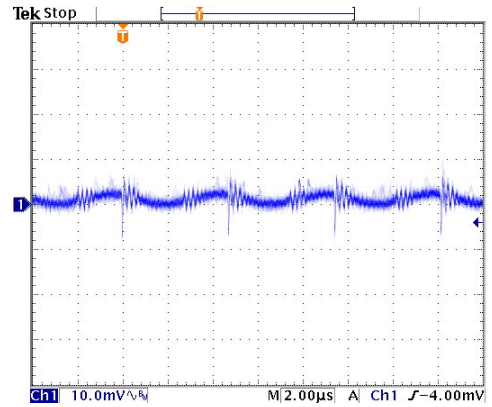

Typical Output Ripple and Noise.

$V_{in} = V_{in,nom}$, Full Load

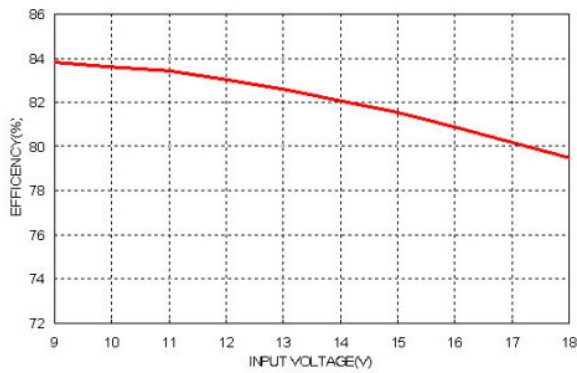

Efficiency versus Input Voltage. Full Load

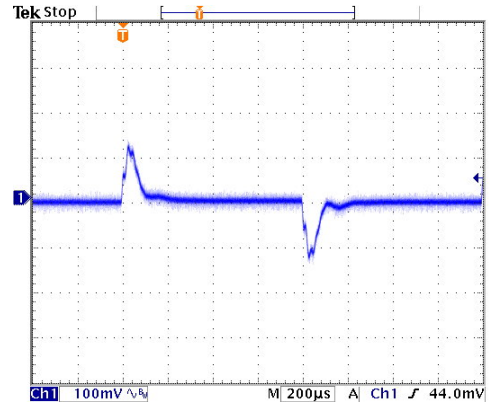

Transient Response to Dynamic Load Change from

100% to 75% to 100% of Full Load ; $V_{in} = V_{in,nom}$

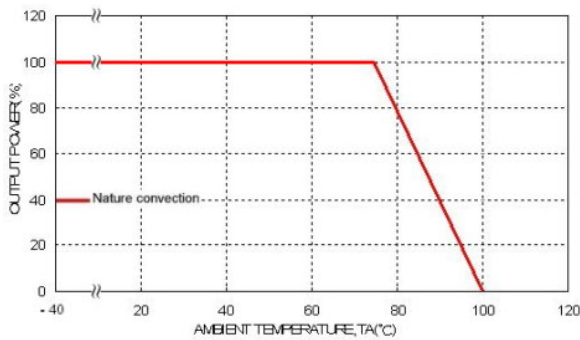

Derating Output Current versus Ambient Temperature and Airflow $V_{in} = V_{in,nom}$

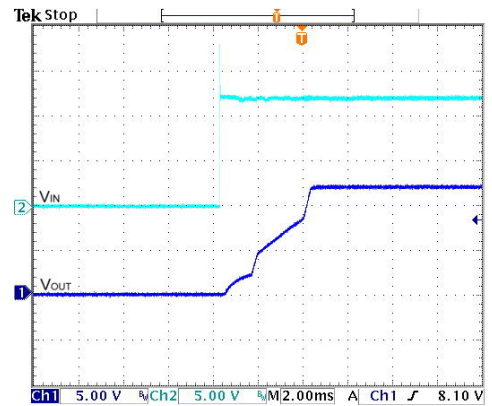

Typical Input Start-Up and Output Rise Characteristic

$V_{in} = V_{in,nom}$, Full Load

Characteristic Curves

All test conditions are at 25°C. The figures are identical for TMR 3-1212 (Continued)

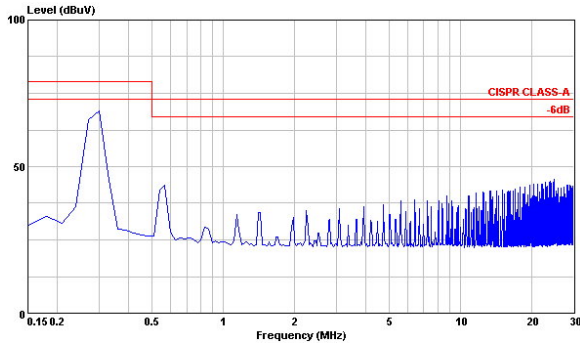

Conduction Emission of EN55022 Class A

$V_{in} = V_{in,nom}$, Full Load

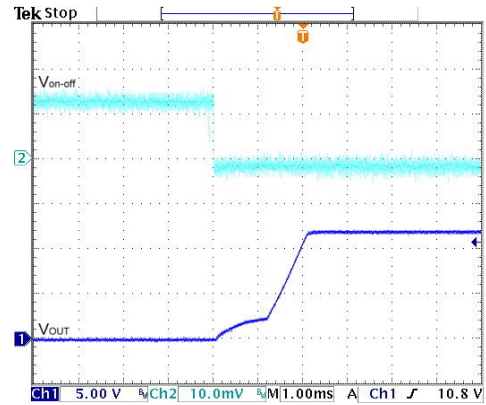

Using ON/OFF Voltage Start-Up and V_{out} Rise Characteristic

$V_{in} = V_{in,nom}$, Full Load

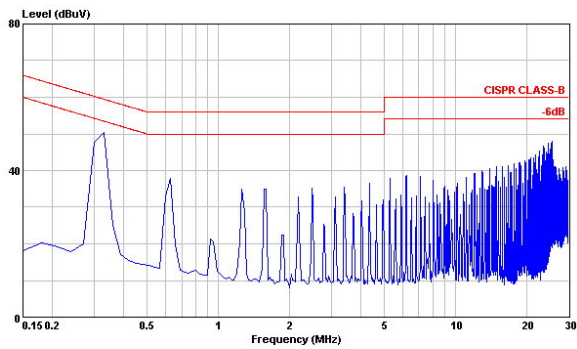

Conduction Emission of EN55022 Class B

$V_{in} = V_{in,nom}$, Full Load

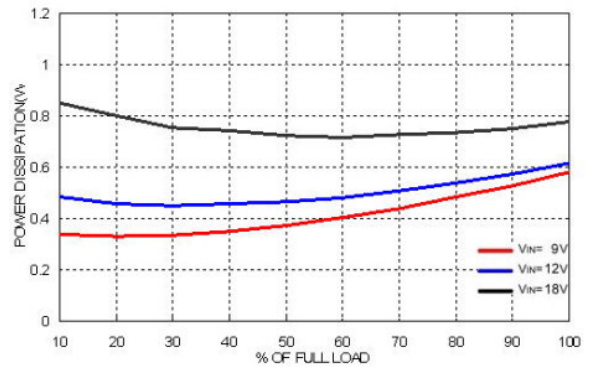

Power Dissipation versus Output Current

Characteristic Curves

All test conditions are at 25°C. The figures are identical for TMR 3-1213

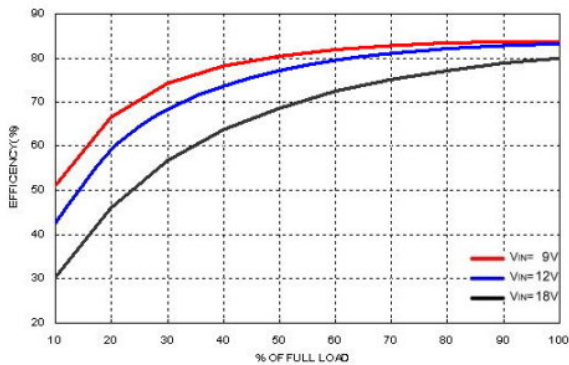

Efficiency versus Output Current

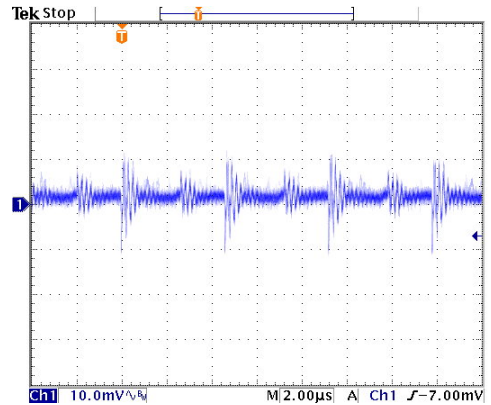

Typical Output Ripple and Noise.

$V_{in} = V_{in,nom}$, Full Load

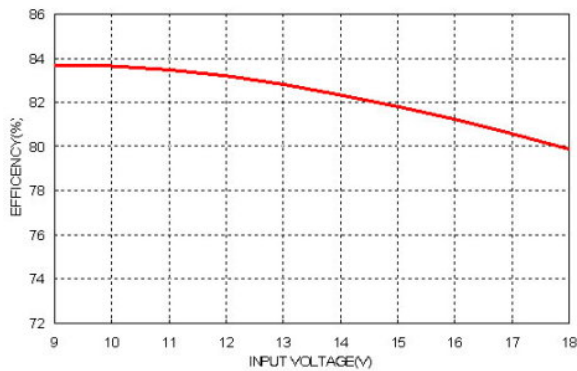

Efficiency versus Input Voltage. Full Load

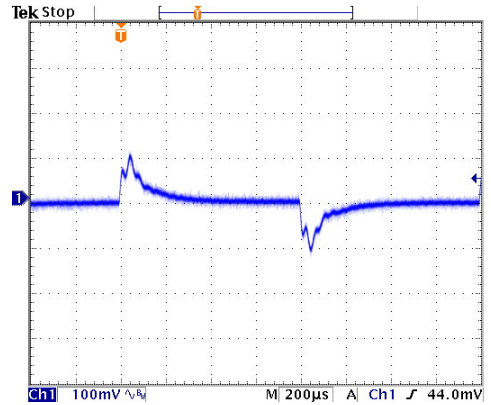

Transient Response to Dynamic Load Change from

100% to 75% to 100% of Full Load ; $V_{in} = V_{in,nom}$

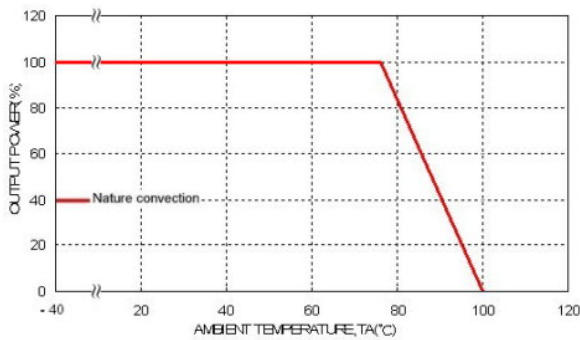

Derating Output Current versus Ambient Temperature and Airflow $V_{in} = V_{in,nom}$

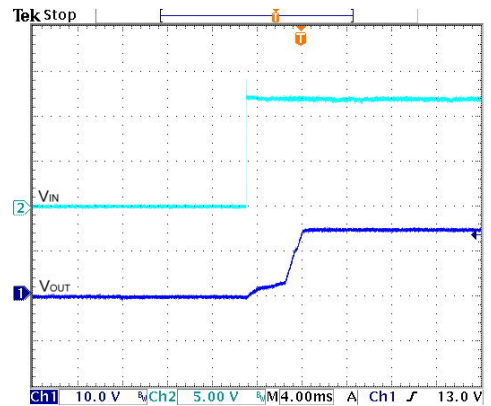

Typical Input Start-Up and Output Rise Characteristic

$V_{in} = V_{in,nom}$, Full Load

Characteristic Curves

All test conditions are at 25°C. The figures are identical for TMR 3-1213 (Continued)

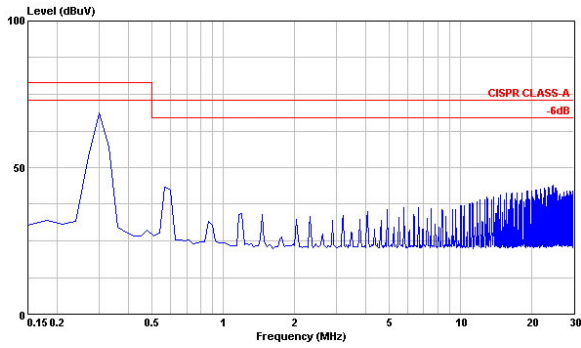

Conduction Emission of EN55022 Class A

$V_{in} = V_{in,nom}$, Full Load

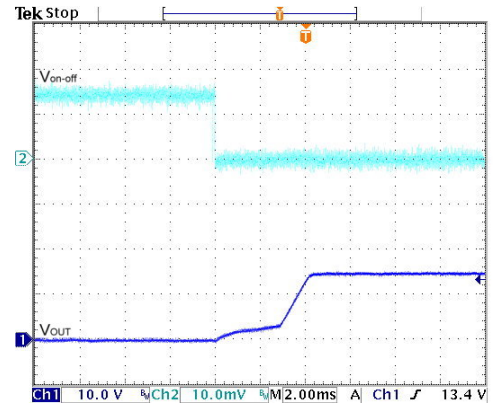

Using ON/OFF Voltage Start-Up and V_{out} Rise Characteristic

$V_{in} = V_{in,nom}$, Full Load

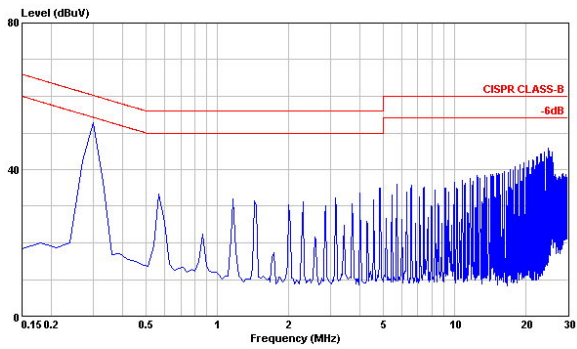

Conduction Emission of EN55022 Class B

$V_{in} = V_{in,nom}$, Full Load

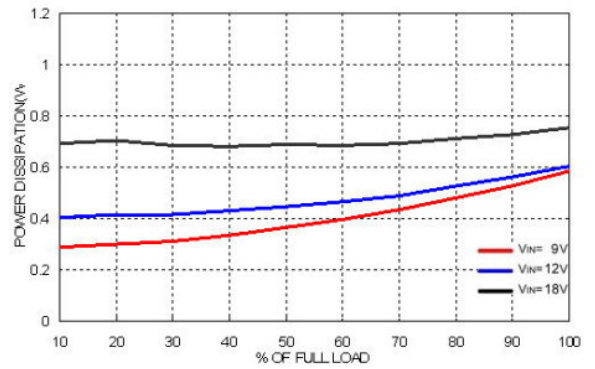

Power Dissipation versus Output Current

Characteristic Curves

All test conditions are at 25°C. The figures are identical for TMR 3-1221

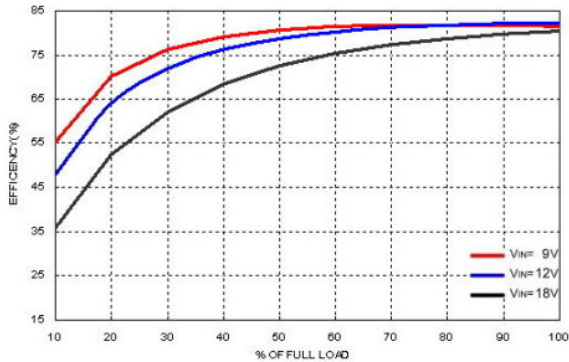

Efficiency versus Output Current

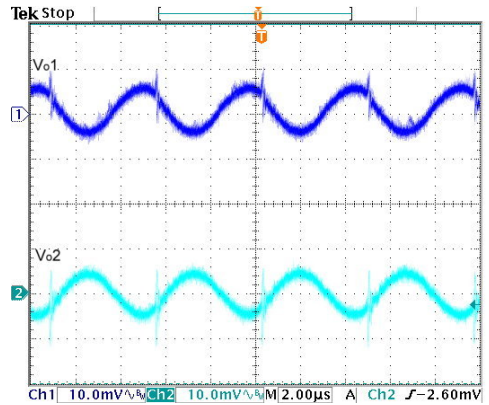

Typical Output Ripple and Noise.

$V_{in} = V_{in,nom}$, Full Load

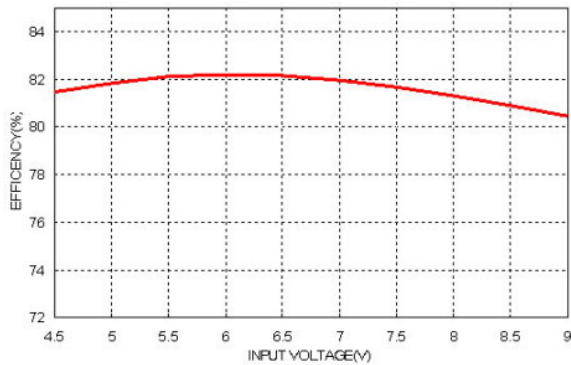

Efficiency versus Input Voltage. Full Load

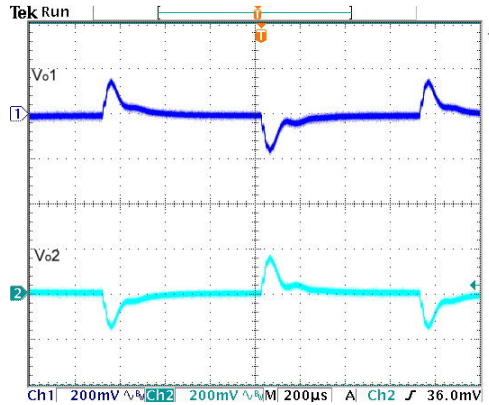

Transient Response to Dynamic Load Change from 100% to 75% to 100% of Full Load ; $V_{in} = V_{in,nom}$

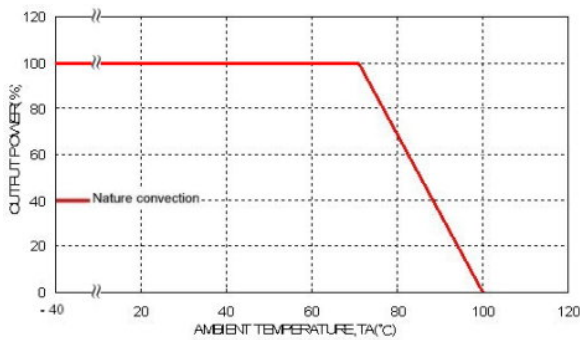

Derating Output Current versus Ambient Temperature and Airflow $V_{in} = V_{in,nom}$

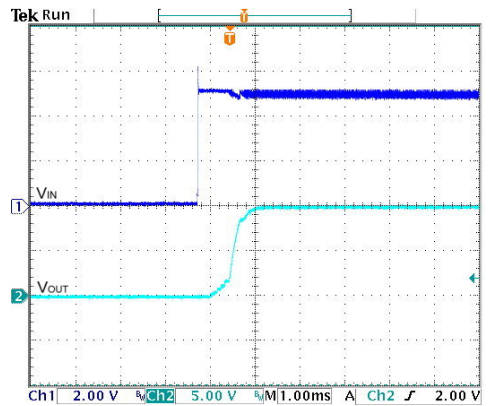

Typical Input Start-Up and Output Rise Characteristic

$V_{in} = V_{in,nom}$, Full Load

Characteristic Curves

All test conditions are at 25°C. The figures are identical for TMR 3-1221 (Continued)

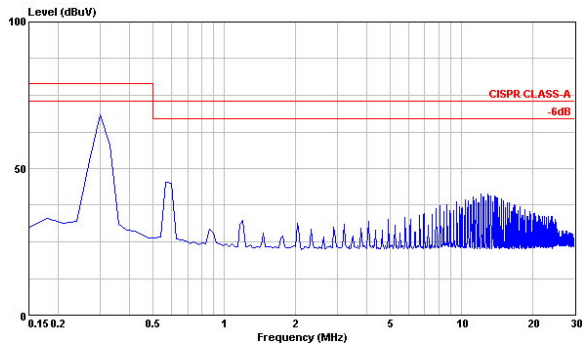

Conduction Emission of EN55022 Class A

$V_{in} = V_{in,nom}$, Full Load

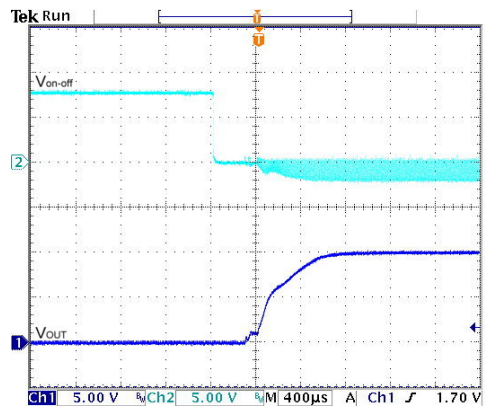

Using ON/OFF Voltage Start-Up and V_{out} Rise Characteristic

$V_{in} = V_{in,nom}$, Full Load

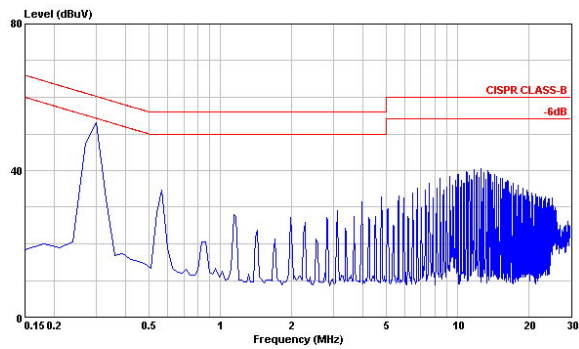

Conduction Emission of EN55022 Class B

$V_{in} = V_{in,nom}$, Full Load

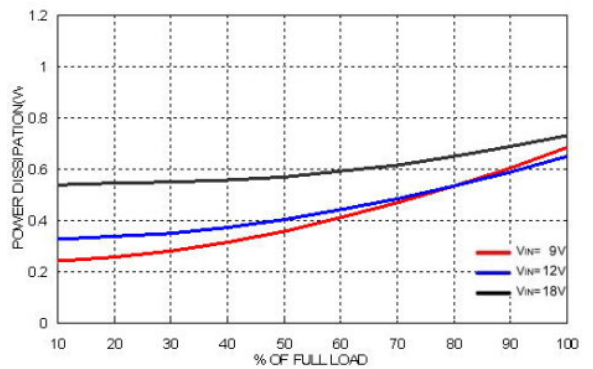

Power Dissipation versus Output Current

Characteristic Curves

All test conditions are at 25°C. The figures are identical for TMR 3-1222

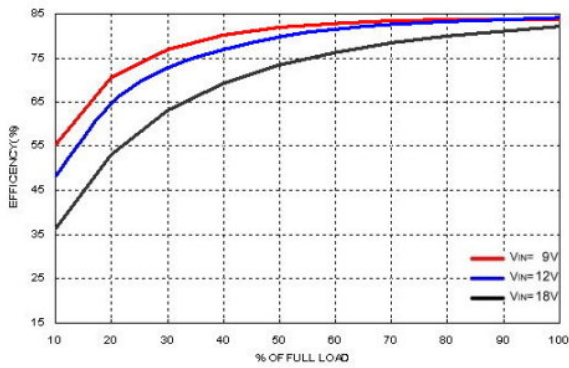

Efficiency versus Output Current

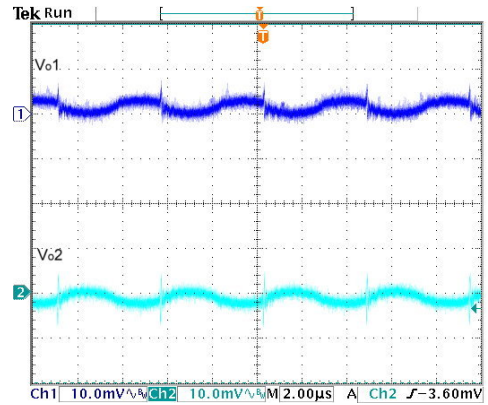

Typical Output Ripple and Noise.

$V_{in} = V_{in,nom}$, Full Load

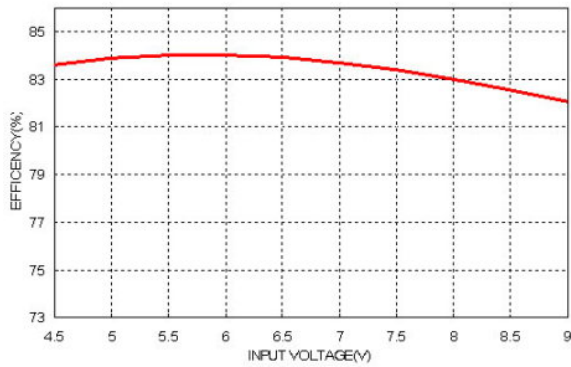

Efficiency versus Input Voltage. Full Load

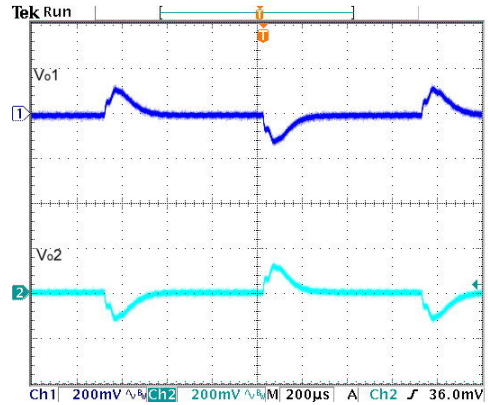

Transient Response to Dynamic Load Change from 100% to 75% to 100% of Full Load ; $V_{in} = V_{in,nom}$

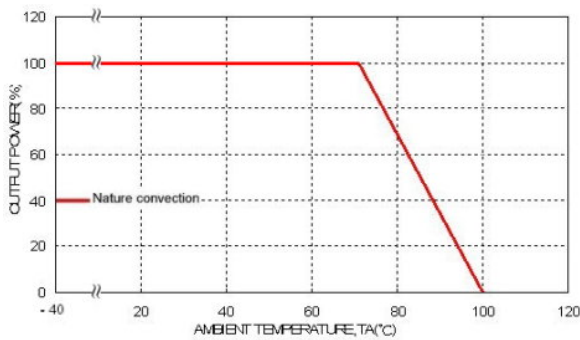

Derating Output Current versus Ambient Temperature and Airflow $V_{in} = V_{in,nom}$

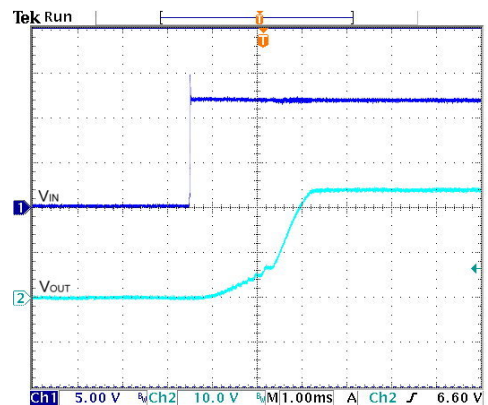

Typical Input Start-Up and Output Rise Characteristic

$V_{in} = V_{in,nom}$, Full Load

Characteristic Curves

All test conditions are at 25°C. The figures are identical for TMR 3-1222 (Continued)

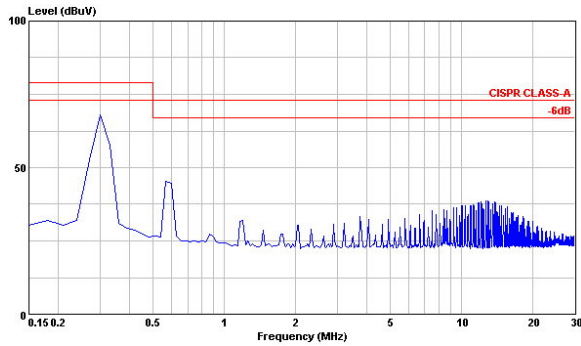

Conduction Emission of EN55022 Class A
 $V_{in} = V_{in,nom}$, Full Load

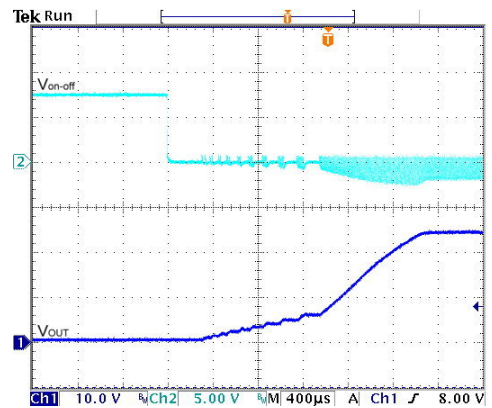

Using ON/OFF Voltage Start-Up and Vo Rise Characteristic
 $V_{in} = V_{in,nom}$, Full Load

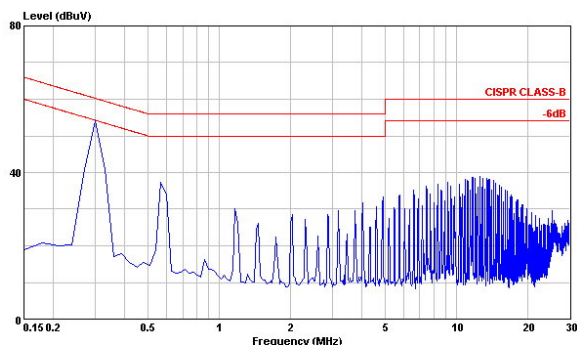

Conduction Emission of EN55022 Class B
 $V_{in} = V_{in,nom}$, Full Load

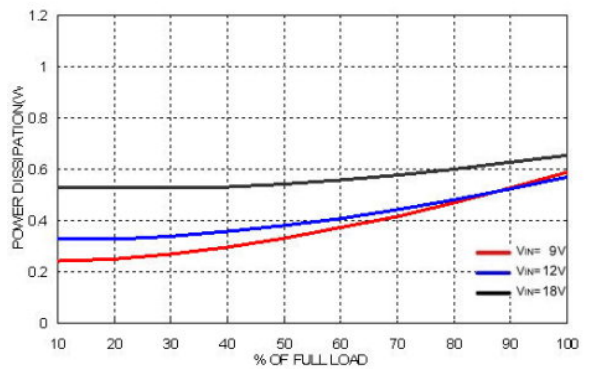

Power Dissipation versus Output Current

Characteristic Curves

All test conditions are at 25°C. The figures are identical for TMR 3-1223

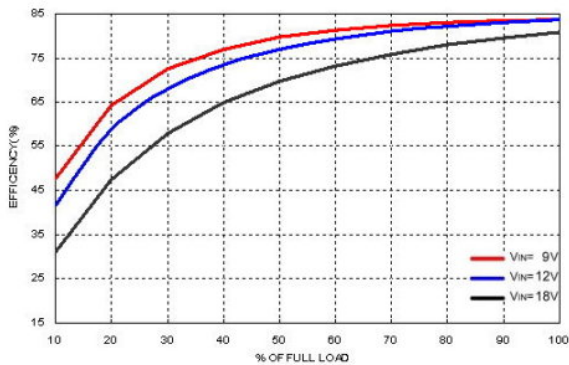

Efficiency versus Output Current

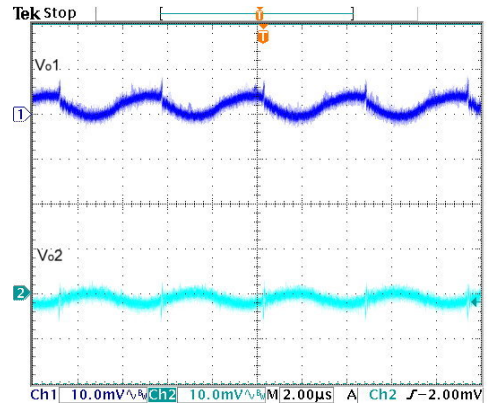

Typical Output Ripple and Noise.

$V_{in} = V_{in,nom}$, Full Load

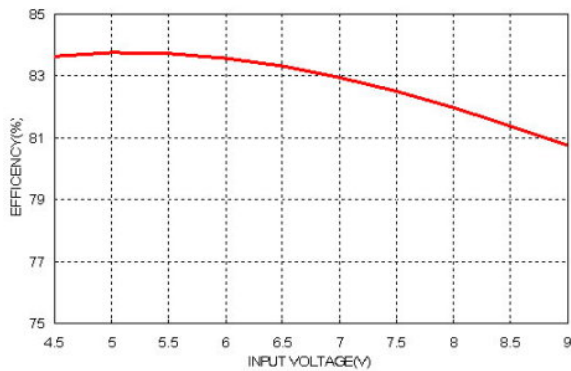

Efficiency versus Input Voltage. Full Load

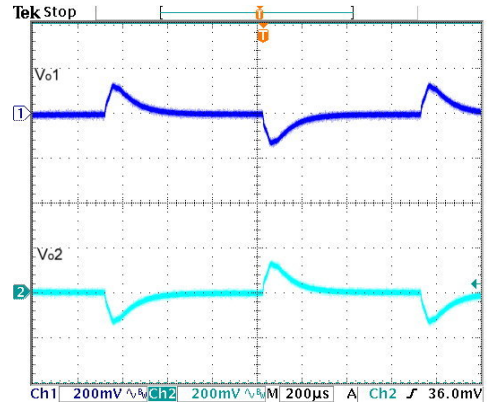

Transient Response to Dynamic Load Change from

100% to 75% to 100% of Full Load ; $V_{in} = V_{in,nom}$

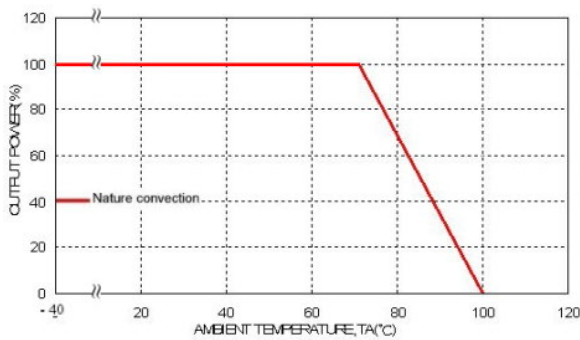

Derating Output Current versus Ambient Temperature and Airflow $V_{in} = V_{in,nom}$

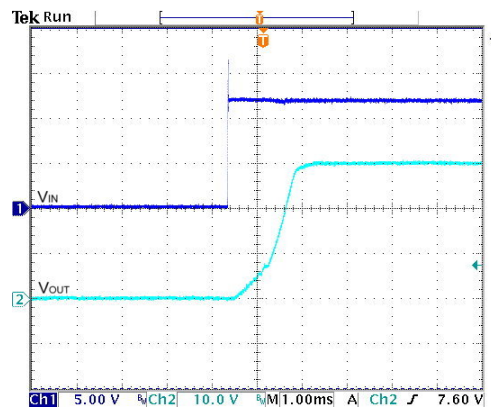

Typical Input Start-Up and Output Rise Characteristic

$V_{in} = V_{in,nom}$, Full Load

Characteristic Curves

All test conditions are at 25°C. The figures are identical for TMR 3-1223(Continued)

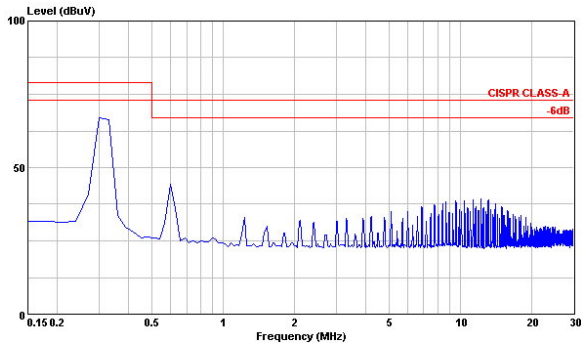

Conduction Emission of EN55022 Class A

$V_{in} = V_{in,nom}$, Full Load

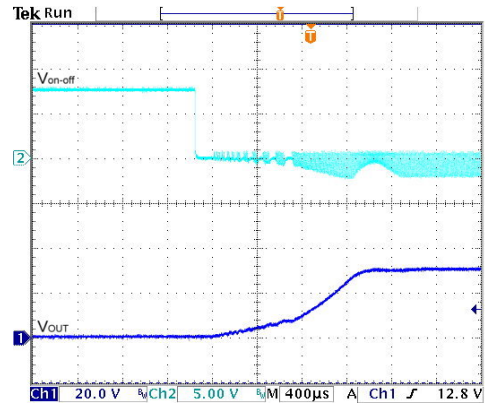

Using ON/OFF Voltage Start-Up and V_{out} Rise Characteristic

$V_{in} = V_{in,nom}$, Full Load

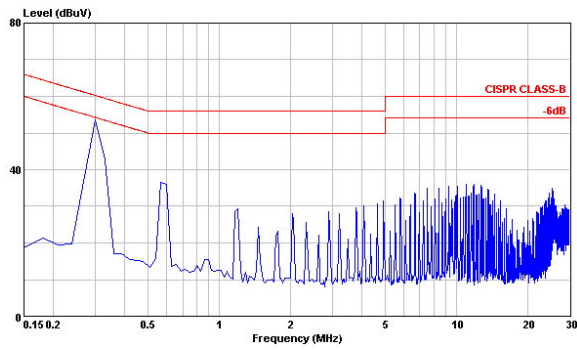

Conduction Emission of EN55022 Class B

$V_{in} = V_{in,nom}$, Full Load

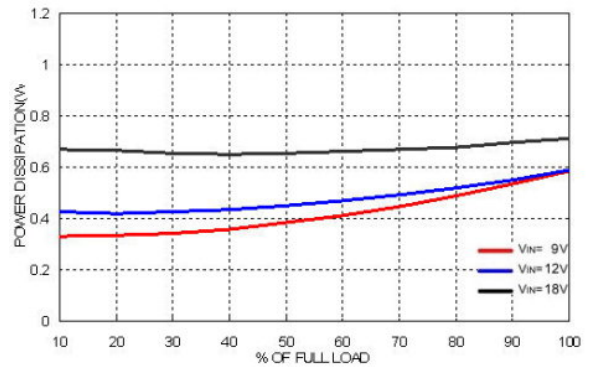

Power Dissipation versus Output Current

Characteristic Curves

All test conditions are at 25°C. The figures are identical for TMR 3-2410

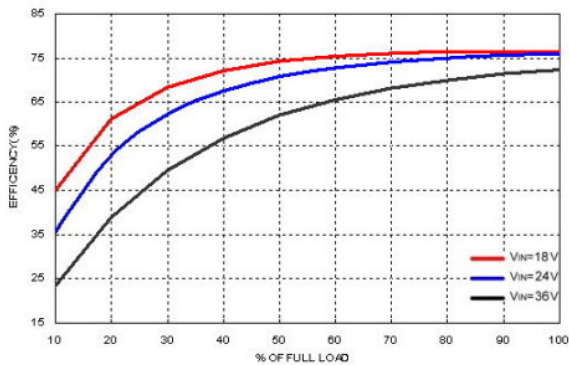

Efficiency versus Output Current

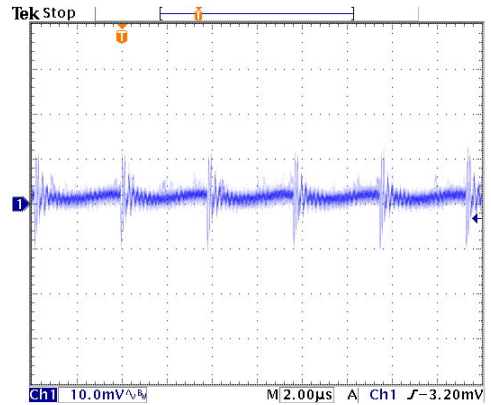

Typical Output Ripple and Noise.

$V_{in} = V_{in,nom}$, Full Load

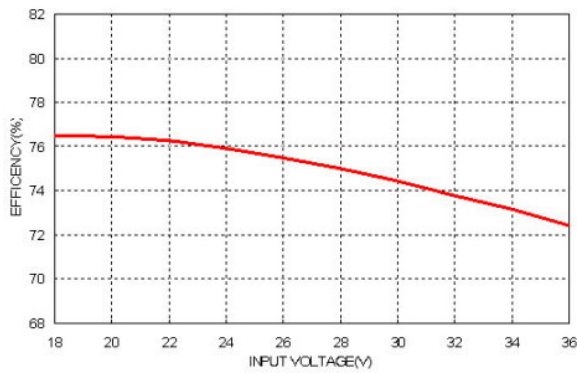

Efficiency versus Input Voltage. Full Load

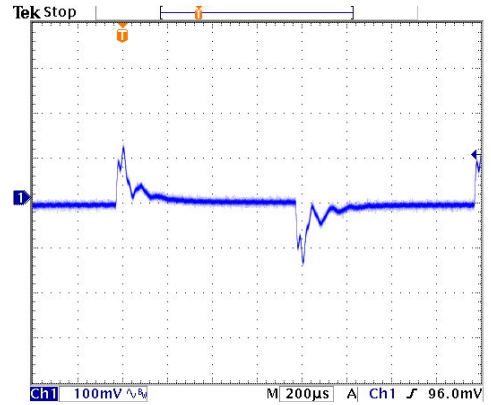

Transient Response to Dynamic Load Change from 100% to 75% to 100% of Full Load ; $V_{in} = V_{in,nom}$

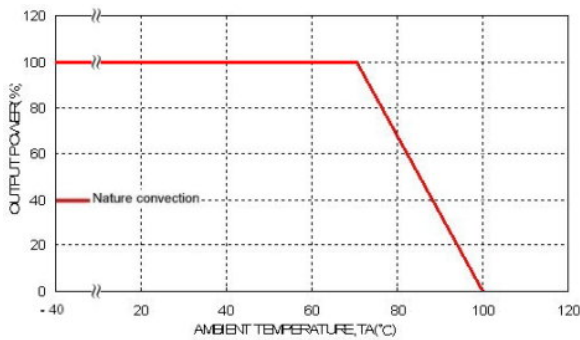

Derating Output Current versus Ambient Temperature and Airflow $V_{in} = V_{in,nom}$

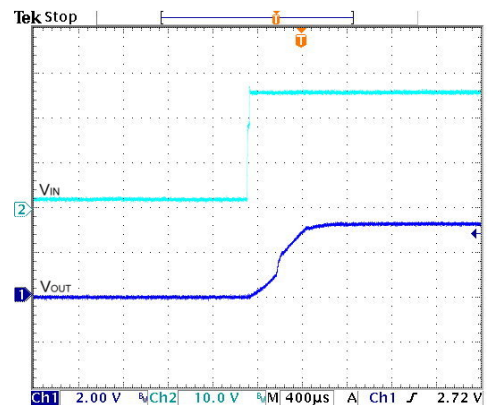

Typical Input Start-Up and Output Rise Characteristic

$V_{in} = V_{in,nom}$, Full Load

Characteristic Curves

All test conditions are at 25°C. The figures are identical for TMR 3-2410 (Continued)

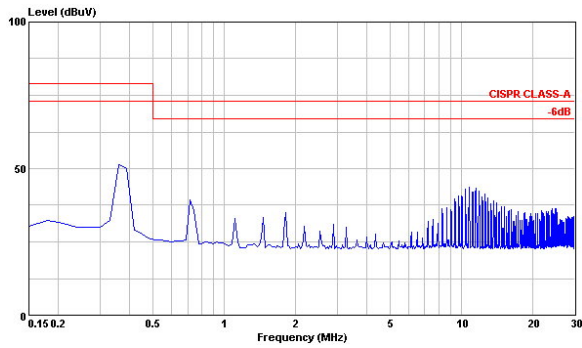

Conduction Emission of EN55022 Class A
 $V_{in} = V_{in,nom}$, Full Load

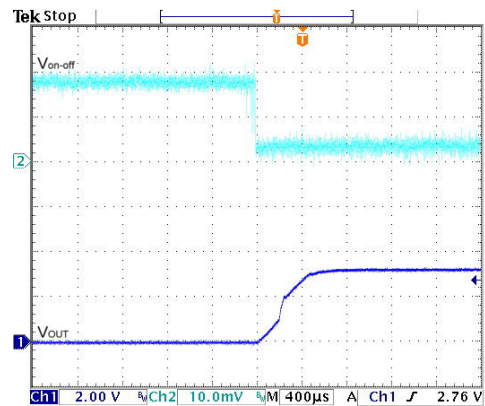

Using ON/OFF Voltage Start-Up and V_{out} Rise Characteristic
 $V_{in} = V_{in,nom}$, Full Load

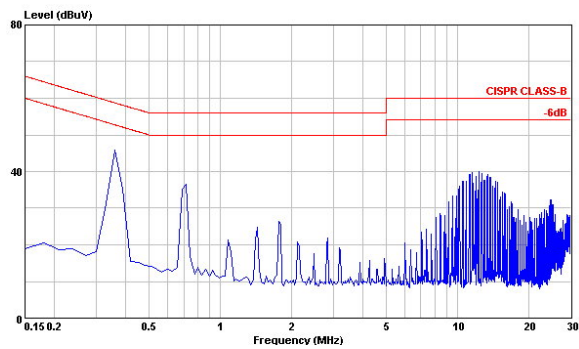

Conduction Emission of EN55022 Class B
 $V_{in} = V_{in,nom}$, Full Load

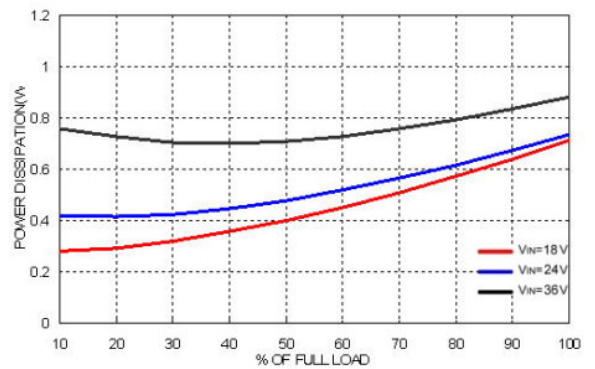

Power Dissipation versus Output Current

Characteristic Curves

All test conditions are at 25°C. The figures are identical for TMR 3-2411

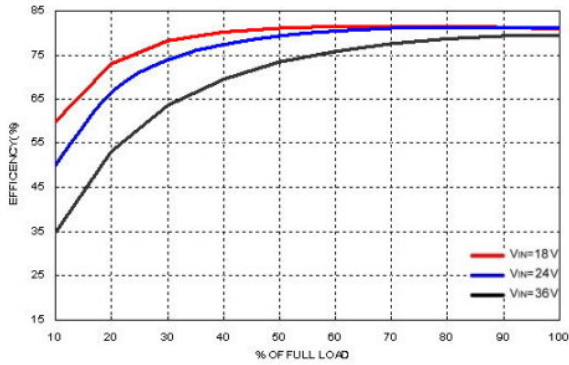

Efficiency versus Output Current

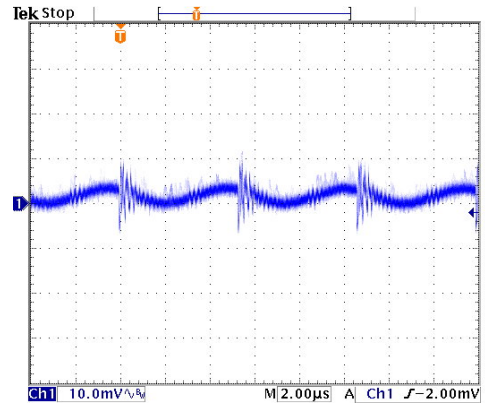

Typical Output Ripple and Noise.

$V_{in} = V_{in,nom}$, Full Load

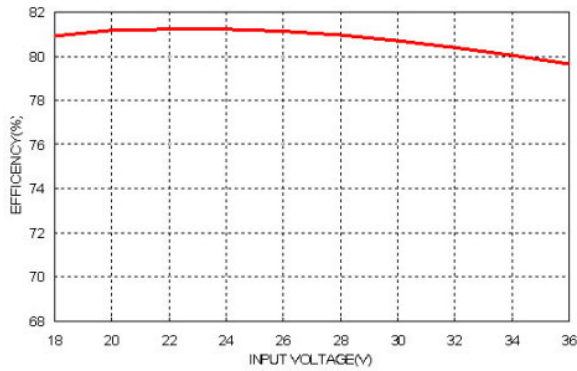

Efficiency versus Input Voltage. Full Load

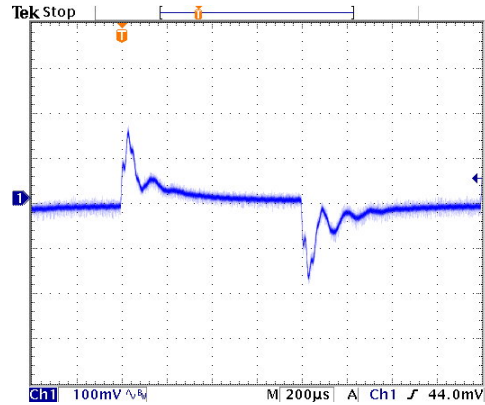

Transient Response to Dynamic Load Change from

100% to 75% to 100% of Full Load ; $V_{in} = V_{in,nom}$

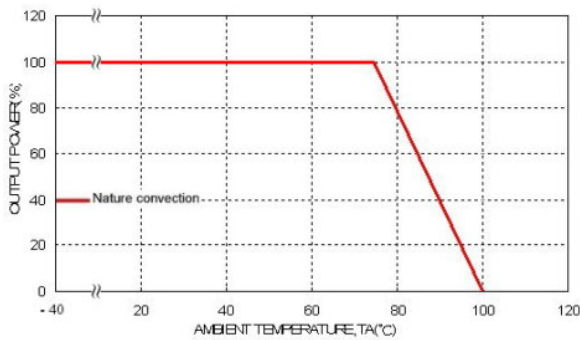

Derating Output Current versus Ambient Temperature and Airflow $V_{in} = V_{in,nom}$

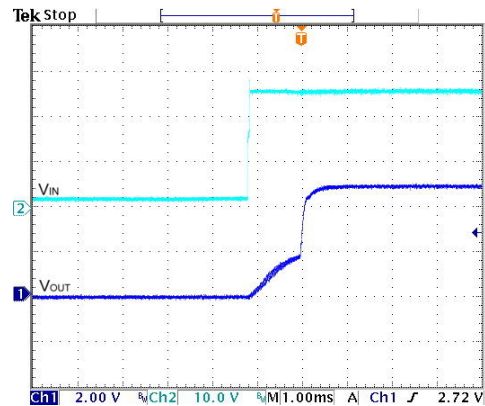

Typical Input Start-Up and Output Rise Characteristic

$V_{in} = V_{in,nom}$, Full Load

Characteristic Curves

All test conditions are at 25°C. The figures are identical for TMR 3-2411 (Continued)

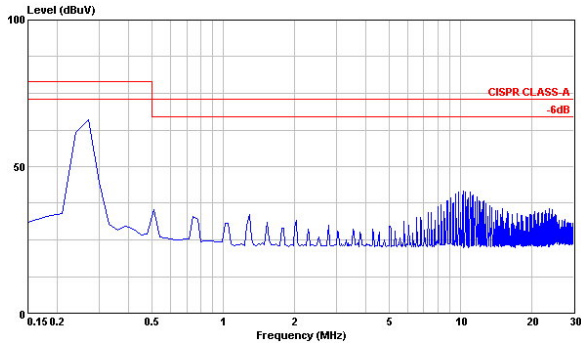

Conduction Emission of EN55022 Class A

$V_{in} = V_{in,nom}$, Full Load

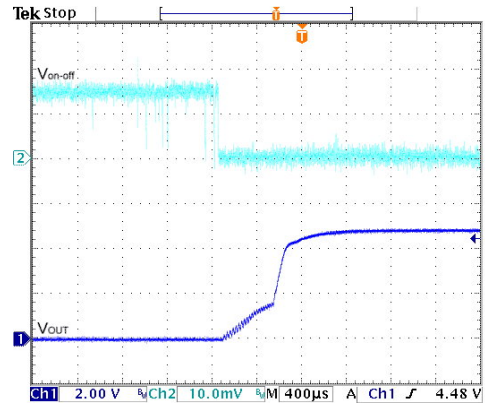

Using ON/OFF Voltage Start-Up and V_{out} Rise Characteristic

$V_{in} = V_{in,nom}$, Full Load

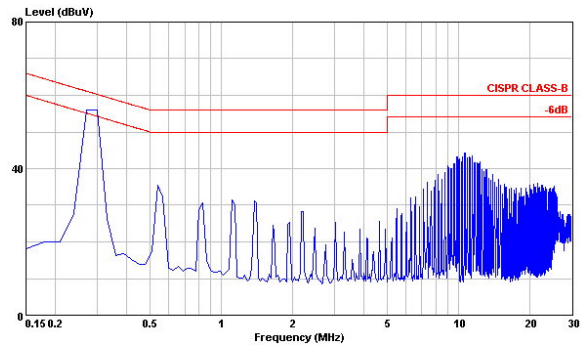

Conduction Emission of EN55022 Class B

$V_{in} = V_{in,nom}$, Full Load

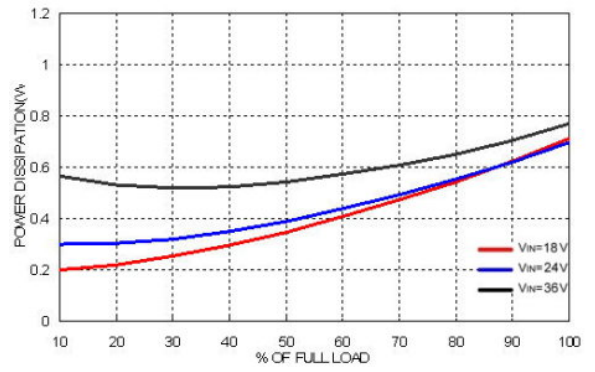

Power Dissipation versus Output Current

Characteristic Curves

All test conditions are at 25°C. The figures are identical for TMR 3-2409

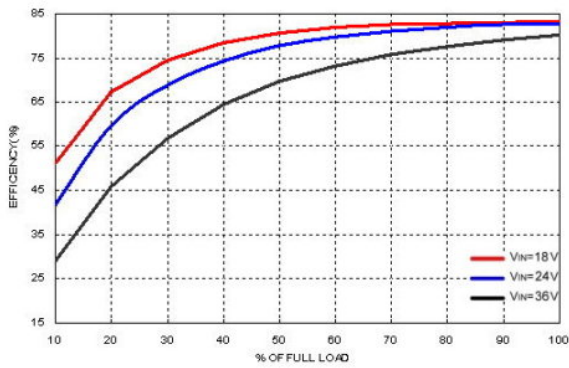

Efficiency versus Output Current

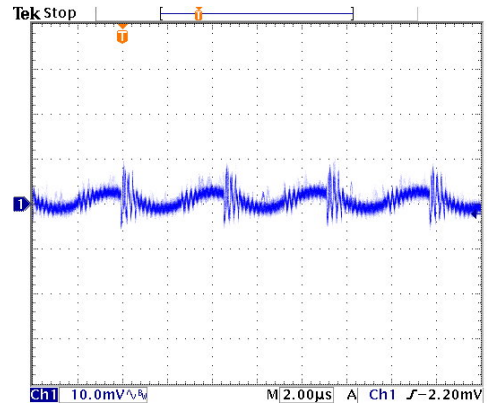

Typical Output Ripple and Noise.

$V_{in} = V_{in,nom}$, Full Load

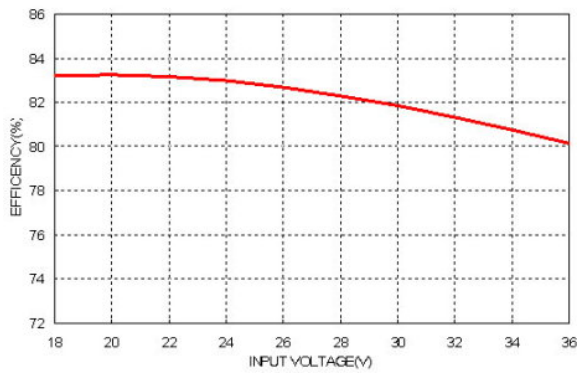

Efficiency versus Input Voltage. Full Load

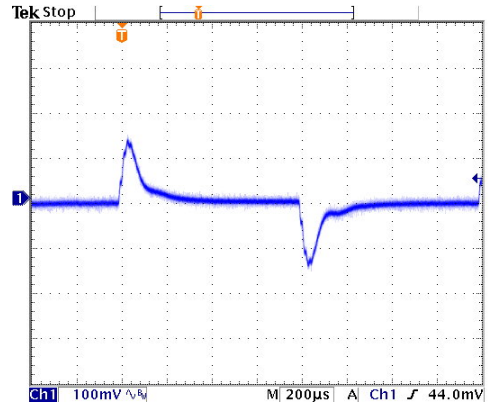

Transient Response to Dynamic Load Change from

100% to 75% to 100% of Full Load ; $V_{in} = V_{in,nom}$

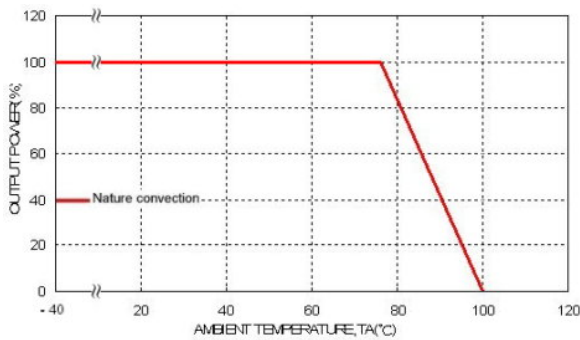

Derating Output Current versus Ambient Temperature and Airflow $V_{in} = V_{in,nom}$

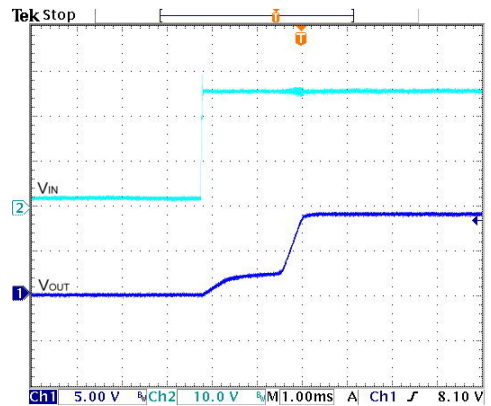

Typical Input Start-Up and Output Rise Characteristic

$V_{in} = V_{in,nom}$, Full Load

Characteristic Curves

All test conditions are at 25°C. The figures are identical for TMR 3-2409 (Continued)

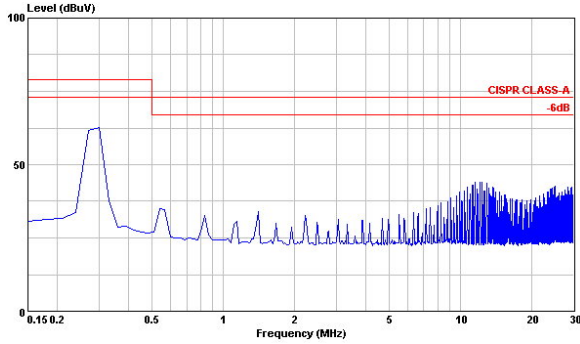

Conduction Emission of EN55022 Class A

$V_{in} = V_{in,nom}$, Full Load

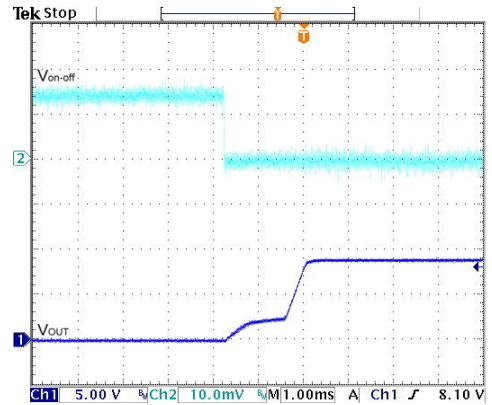

Using ON/OFF Voltage Start-Up and V_{out} Rise Characteristic

$V_{in} = V_{in,nom}$, Full Load

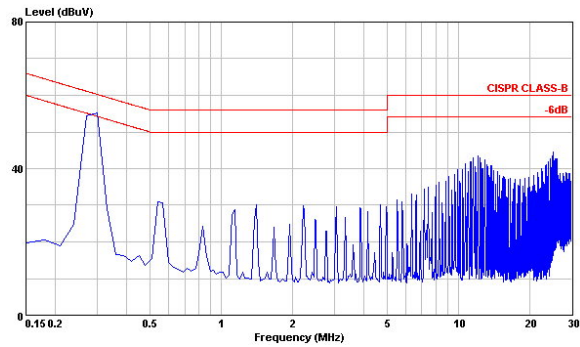

Conduction Emission of EN55022 Class B

$V_{in} = V_{in,nom}$, Full Load

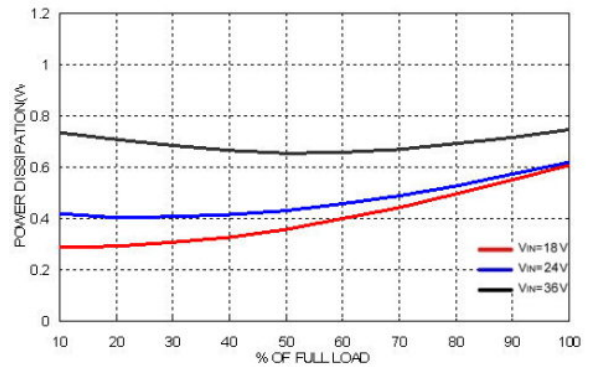

Power Dissipation versus Output Current

Characteristic Curves

All test conditions are at 25°C. The figures are identical for TMR 3-2412

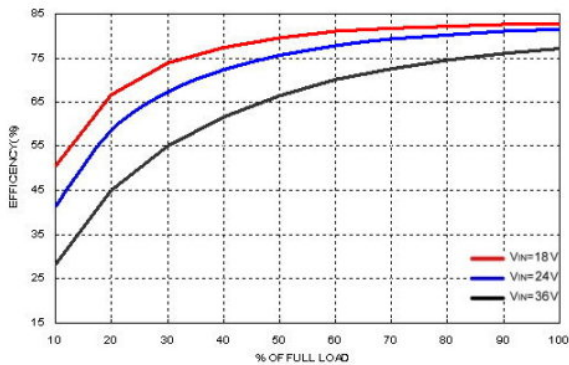

Efficiency versus Output Current

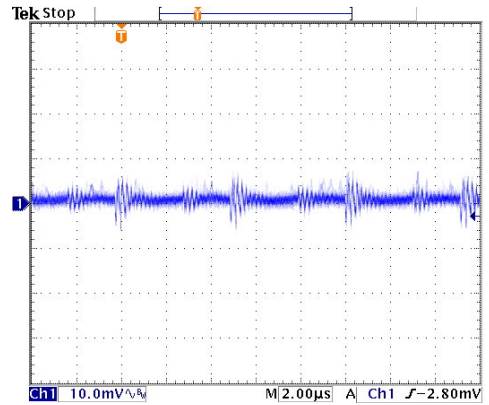

Typical Output Ripple and Noise.

$V_{in} = V_{in,nom}$, Full Load

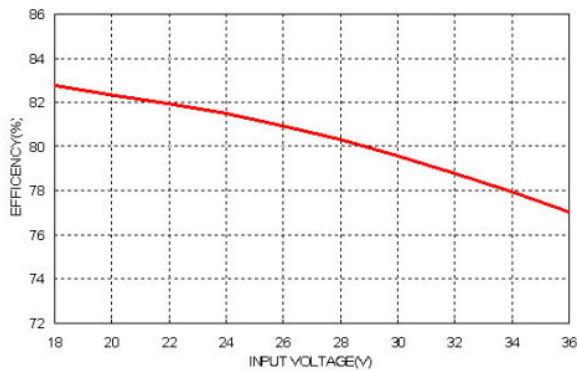

Efficiency versus Input Voltage. Full Load

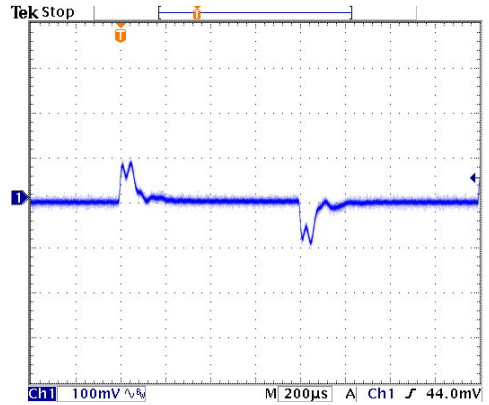

Transient Response to Dynamic Load Change from

100% to 75% to 100% of Full Load ; $V_{in} = V_{in,nom}$

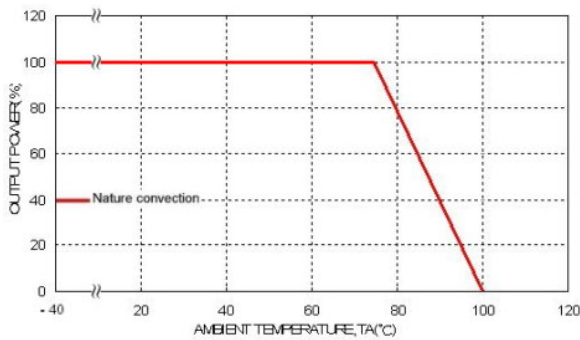

Derating Output Current versus Ambient Temperature and Airflow $V_{in} = V_{in,nom}$

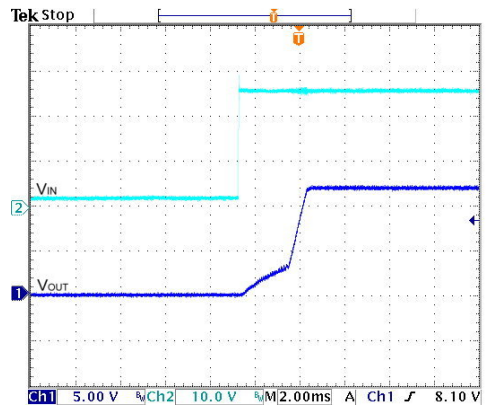

Typical Input Start-Up and Output Rise Characteristic

$V_{in} = V_{in,nom}$, Full Load

Characteristic Curves

All test conditions are at 25°C. The figures are identical for TMR 3-2412 (Continued)

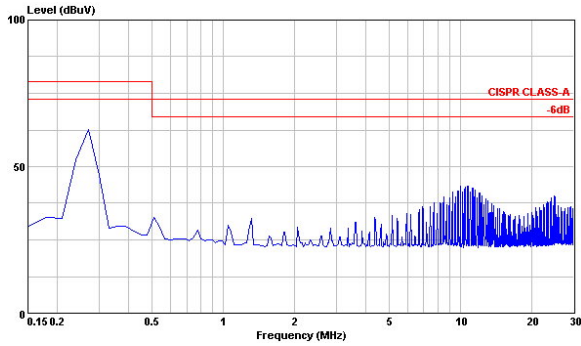

Conduction Emission of EN55022 Class A

$V_{in} = V_{in,nom}$, Full Load

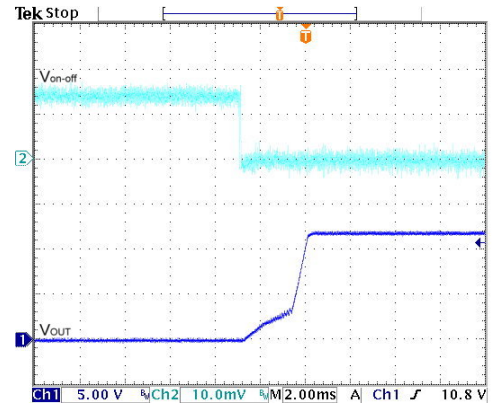

Using ON/OFF Voltage Start-Up and V_{out} Rise Characteristic

$V_{in} = V_{in,nom}$, Full Load

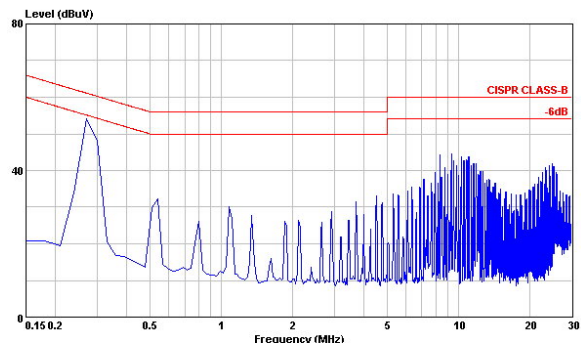

Conduction Emission of EN55022 Class B

$V_{in} = V_{in,nom}$, Full Load

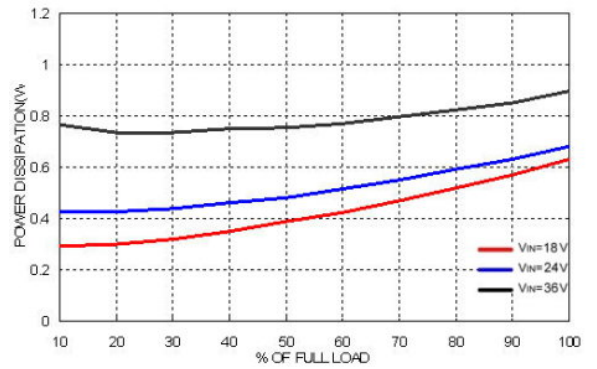

Power Dissipation versus Output Current

Characteristic Curves

All test conditions are at 25°C. The figures are identical for TMR 3-2413

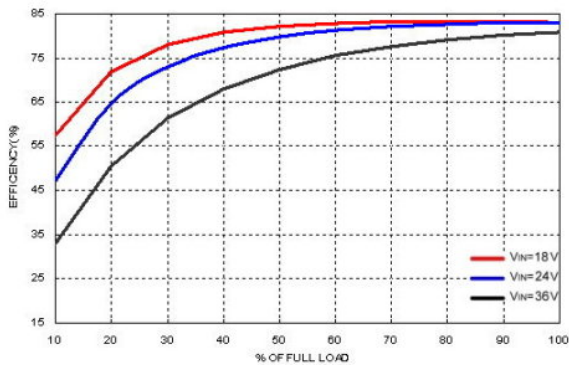

Efficiency versus Output Current

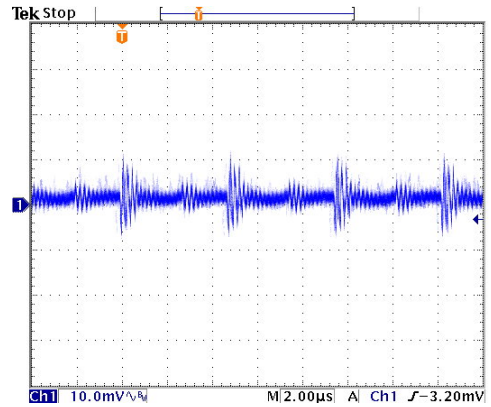

Typical Output Ripple and Noise.

$V_{in} = V_{in,nom}$, Full Load

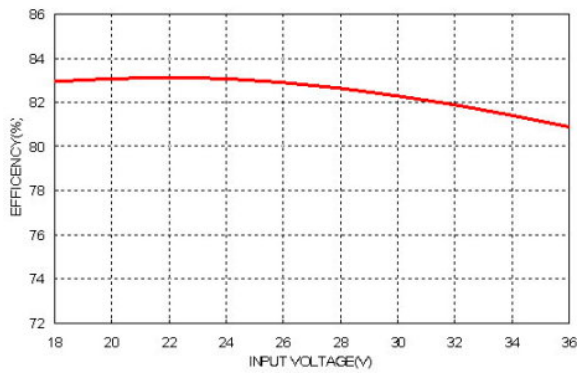

Efficiency versus Input Voltage. Full Load

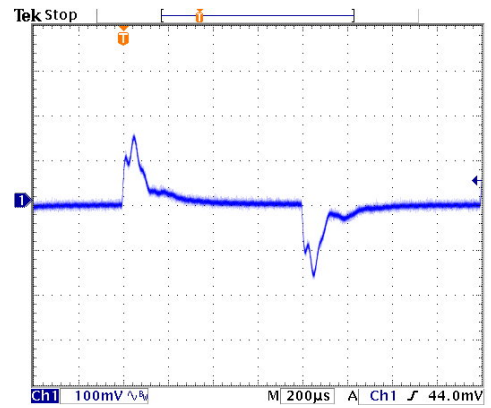

Transient Response to Dynamic Load Change from

100% to 75% to 100% of Full Load ; $V_{in} = V_{in,nom}$

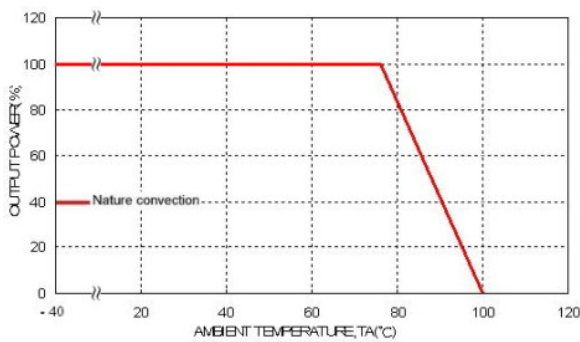

Derating Output Current versus Ambient Temperature and Airflow $V_{in} = V_{in,nom}$

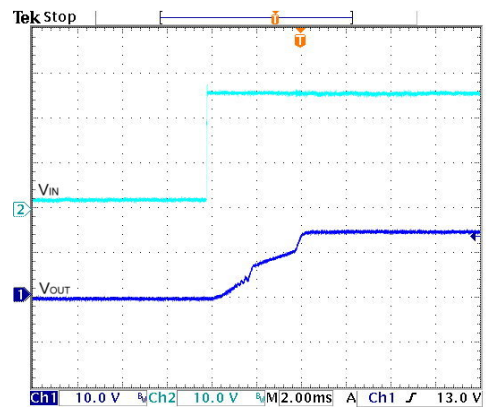

Typical Input Start-Up and Output Rise Characteristic

$V_{in} = V_{in,nom}$, Full Load

Characteristic Curves

All test conditions are at 25°C. The figures are identical for TMR 3-2413 (Continued)

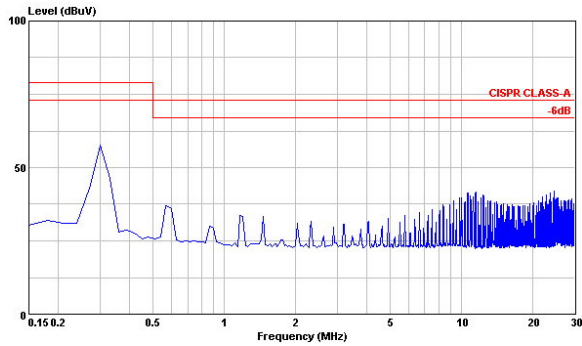

Conduction Emission of EN55022 Class A

$V_{in} = V_{in,nom}$, Full Load

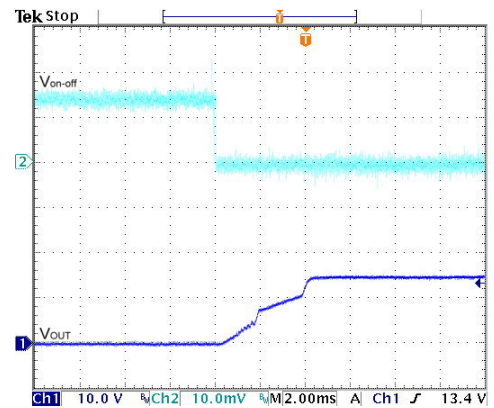

Using ON/OFF Voltage Start-Up and V_{out} Rise Characteristic

$V_{in} = V_{in,nom}$, Full Load

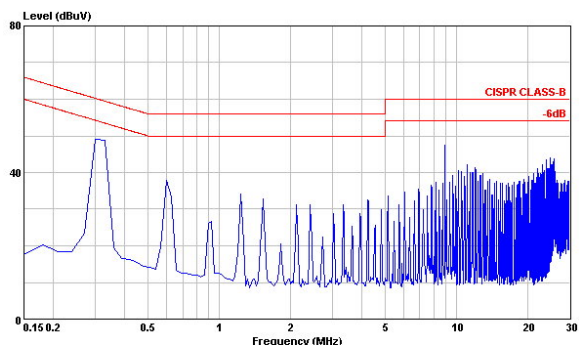

Conduction Emission of EN55022 Class B

$V_{in} = V_{in,nom}$, Full Load

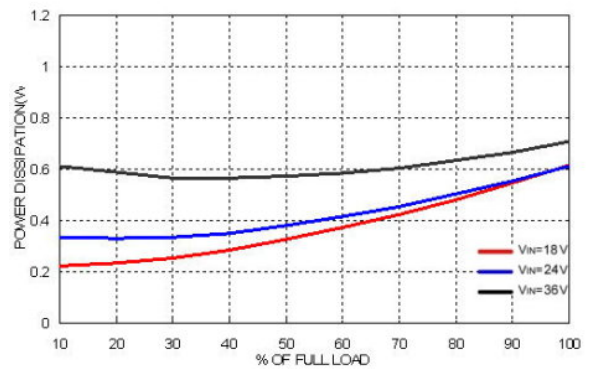

Power Dissipation versus Output Current

Characteristic Curves

All test conditions are at 25°C. The figures are identical for TMR 3-2421

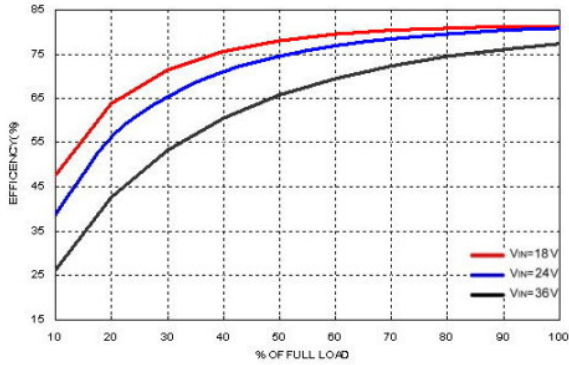

Efficiency versus Output Current

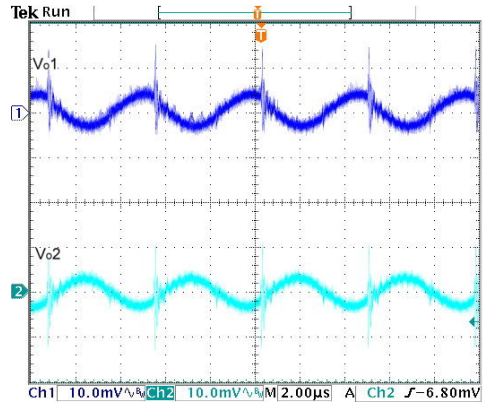

Typical Output Ripple and Noise.

$V_{in} = V_{in,nom}$, Full Load

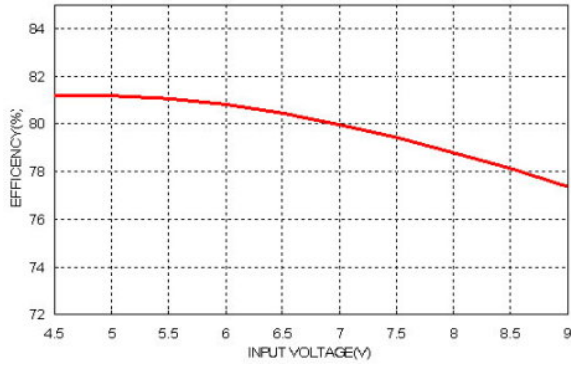

Efficiency versus Input Voltage. Full Load

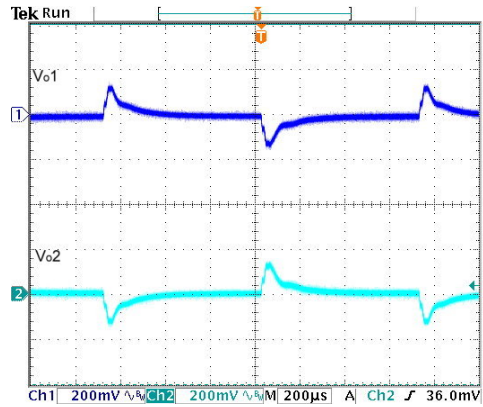

Transient Response to Dynamic Load Change from

100% to 75% to 100% of Full Load ; $V_{in} = V_{in,nom}$

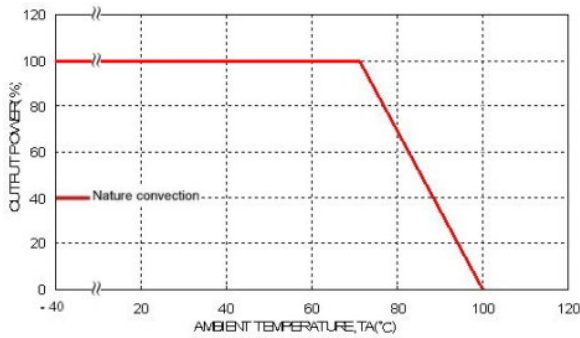

Derating Output Current versus Ambient Temperature and Airflow $V_{in} = V_{in,nom}$

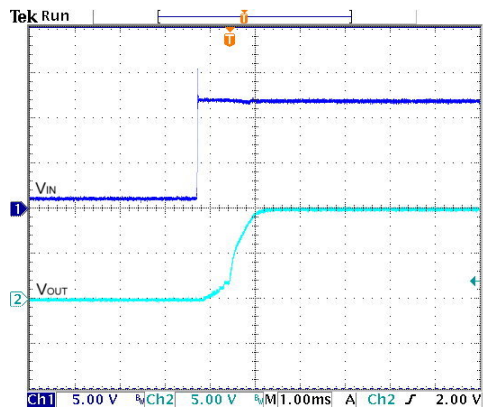

Typical Input Start-Up and Output Rise Characteristic

$V_{in} = V_{in,nom}$, Full Load

Characteristic Curves

All test conditions are at 25°C. The figures are identical for TMR 3-2421 (Continued)

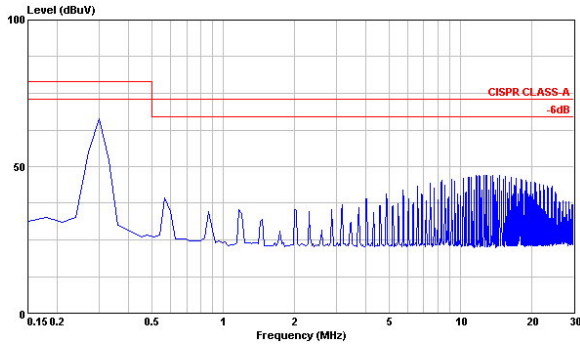

Conduction Emission of EN55022 Class A

$V_{in} = V_{in,nom}$, Full Load

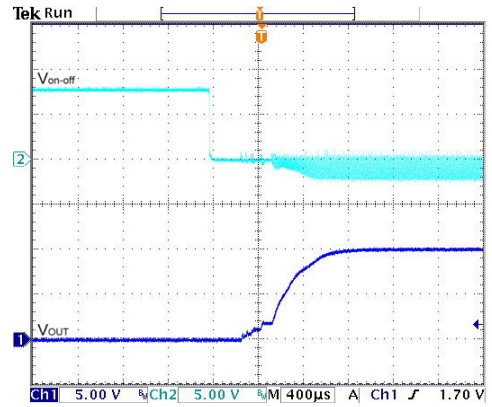

Using ON/OFF Voltage Start-Up and V_{out} Rise Characteristic

$V_{in} = V_{in,nom}$, Full Load

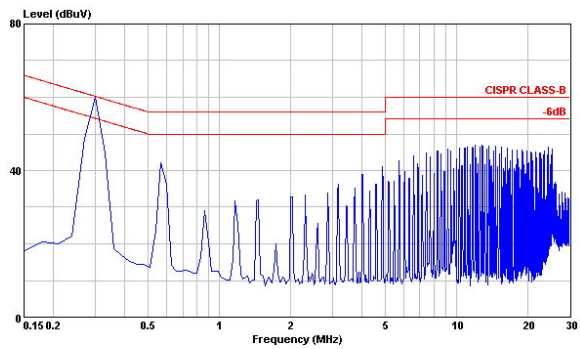

Conduction Emission of EN55022 Class B

$V_{in} = V_{in,nom}$, Full Load

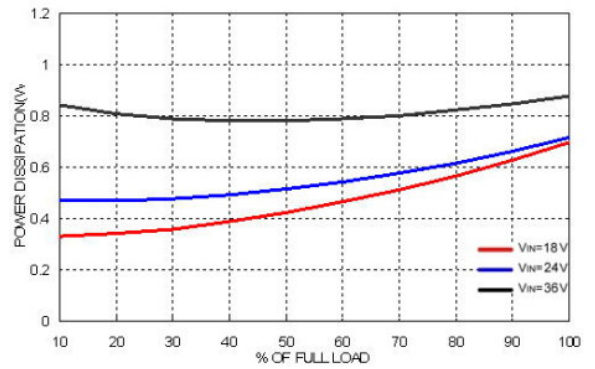

Power Dissipation versus Output Current

Characteristic Curves

All test conditions are at 25°C. The figures are identical for TMR 3-2422

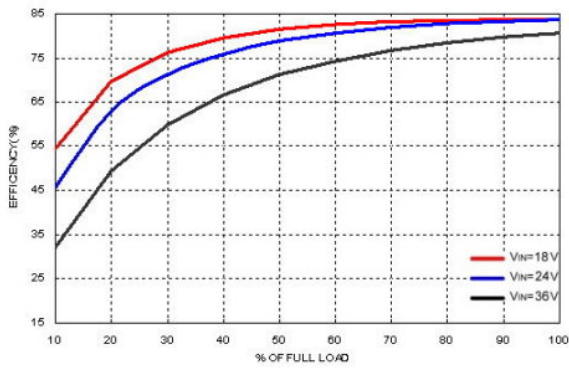

Efficiency versus Output Current

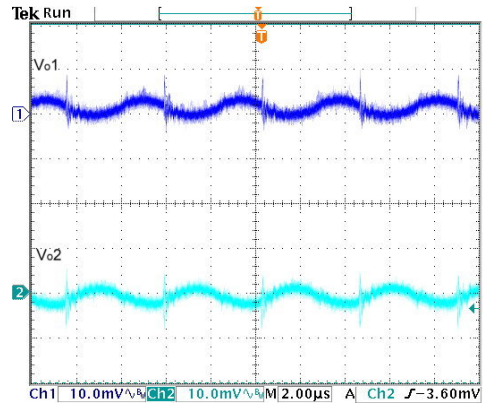

Typical Output Ripple and Noise.

$V_{in} = V_{in,nom}$, Full Load

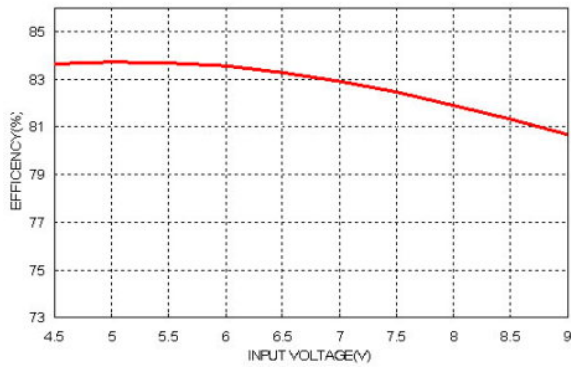

Efficiency versus Input Voltage. Full Load

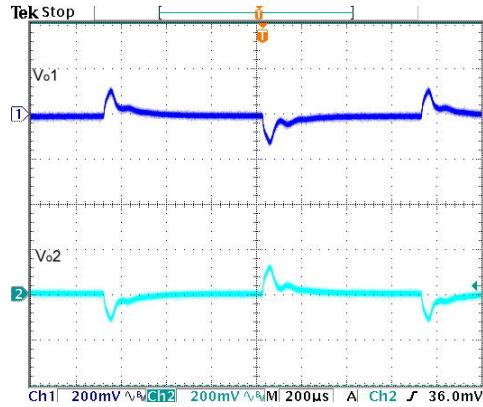

Transient Response to Dynamic Load Change from

100% to 75% to 100% of Full Load ; $V_{in} = V_{in,nom}$

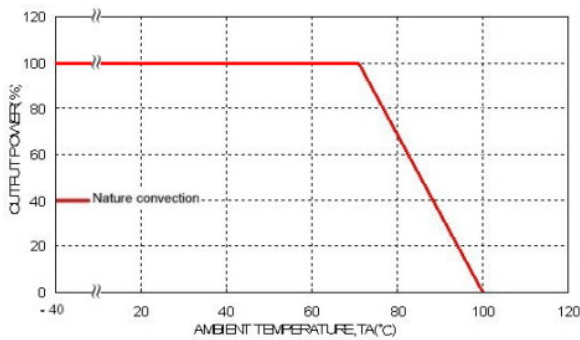

Derating Output Current versus Ambient Temperature and Airflow $V_{in} = V_{in,nom}$

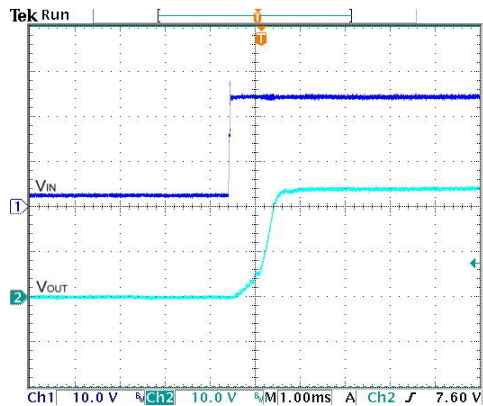

Typical Input Start-Up and Output Rise Characteristic

$V_{in} = V_{in,nom}$, Full Load

Characteristic Curves

All test conditions are at 25°C. The figures are identical for TMR 3-2422 (Continued)

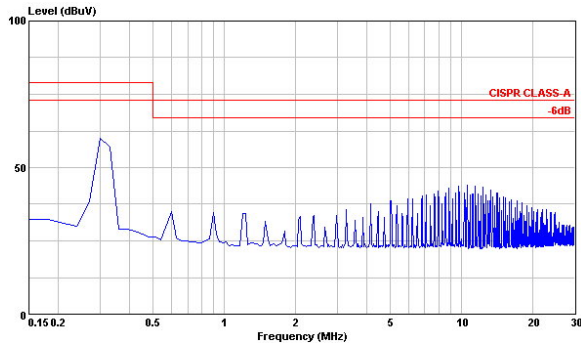

Conduction Emission of EN55022 Class A

$V_{in} = V_{in,nom}$, Full Load

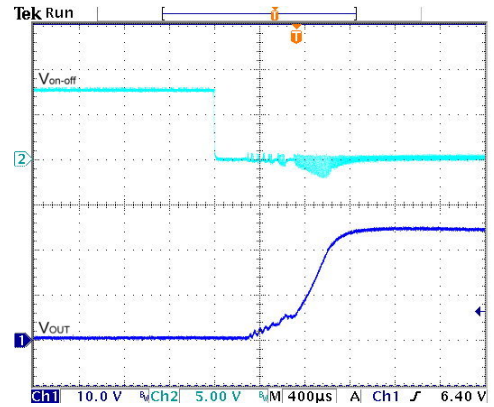

Using ON/OFF Voltage Start-Up and V_{out} Rise Characteristic

$V_{in} = V_{in,nom}$, Full Load

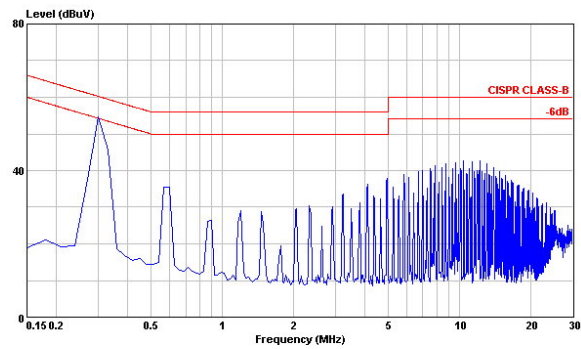

Conduction Emission of EN55022 Class B

$V_{in} = V_{in,nom}$, Full Load

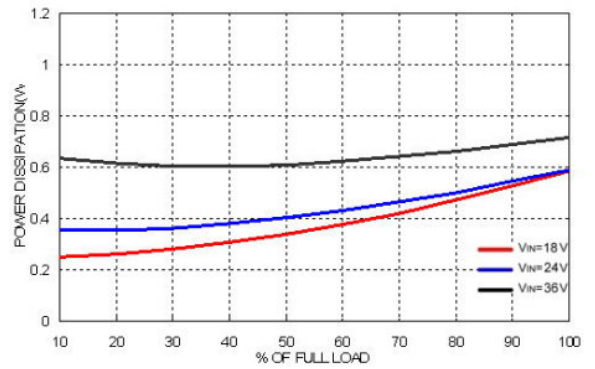

Power Dissipation versus Output Current

Characteristic Curves

All test conditions are at 25°C. The figures are identical for TMR 3-2423

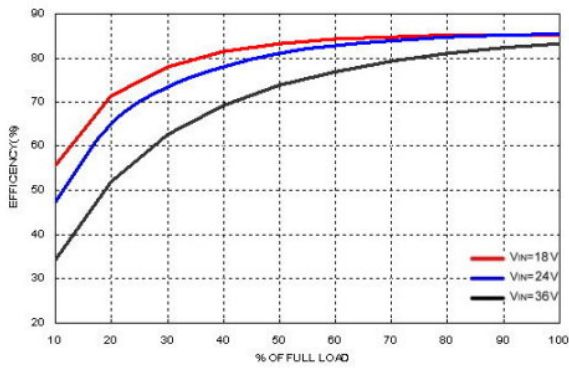

Efficiency versus Output Current

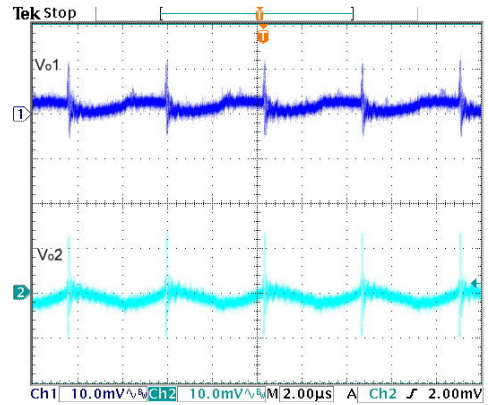

Typical Output Ripple and Noise.

$V_{in} = V_{in,nom}$, Full Load

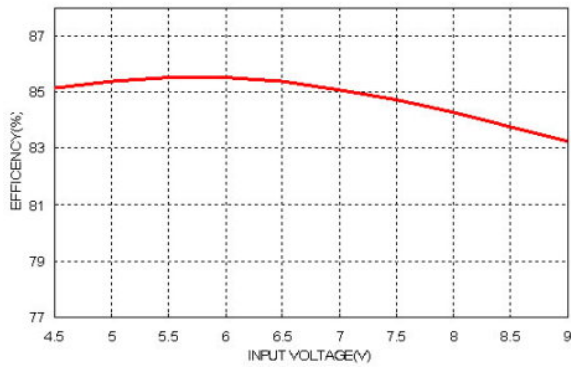

Efficiency versus Input Voltage. Full Load

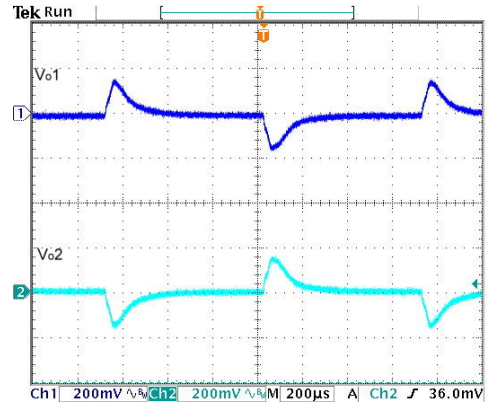

Transient Response to Dynamic Load Change from

100% to 75% to 100% of Full Load ; $V_{in} = V_{in,nom}$

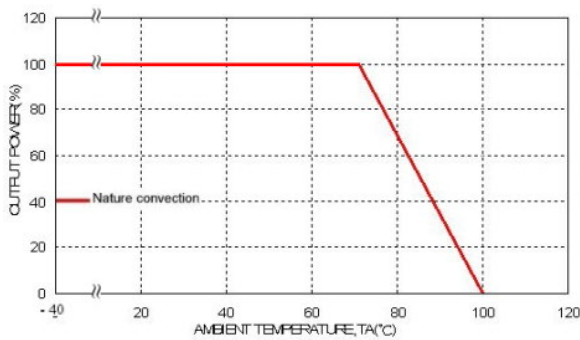

Derating Output Current versus Ambient Temperature and Airflow $V_{in} = V_{in,nom}$

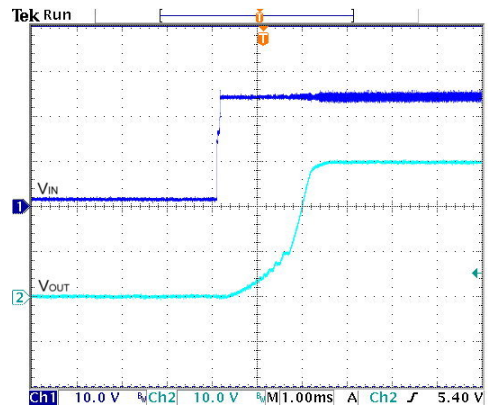

Typical Input Start-Up and Output Rise Characteristic

$V_{in} = V_{in,nom}$, Full Load

Characteristic Curves

All test conditions are at 25°C. The figures are identical for TMR 3-2423 (Continued)

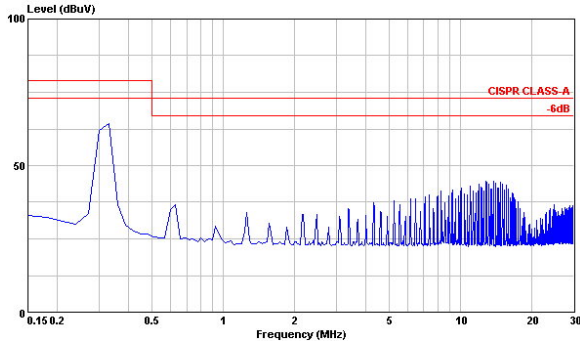

Conduction Emission of EN55022 Class A

$V_{in} = V_{in,nom}$, Full Load

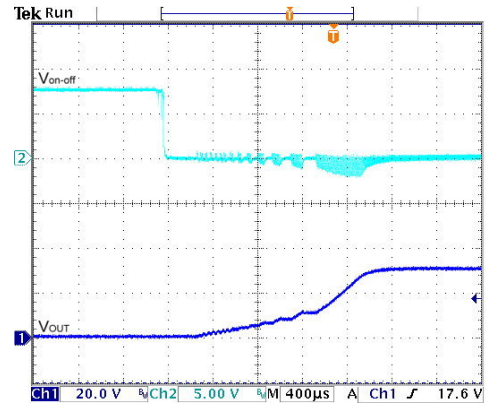

Using ON/OFF Voltage Start-Up and V_{out} Rise Characteristic

$V_{in} = V_{in,nom}$, Full Load

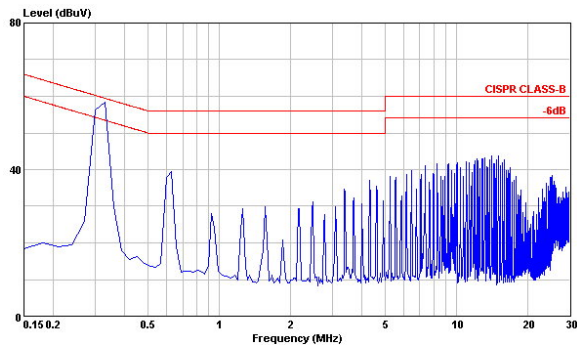

Conduction Emission of EN55022 Class B

$V_{in} = V_{in,nom}$, Full Load

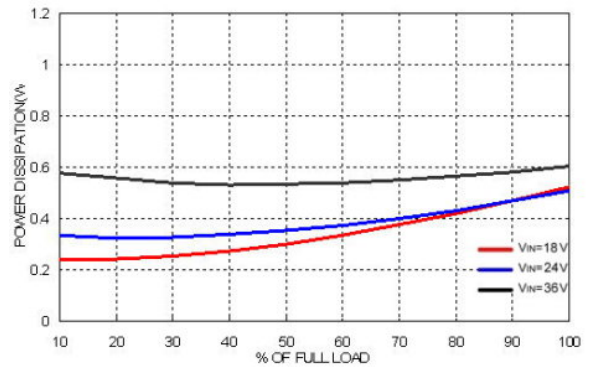

Power Dissipation versus Output Current

Characteristic Curves

All test conditions are at 25°C. The figures are identical for TMR 3-4810

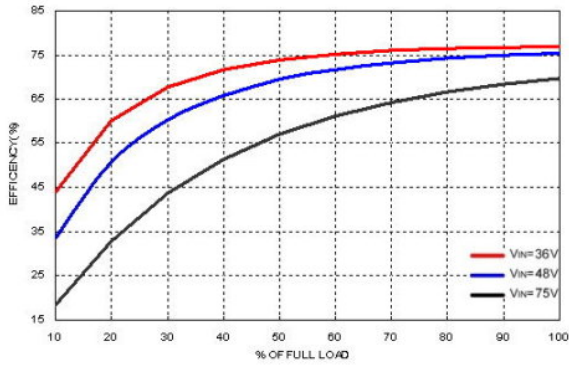

Efficiency versus Output Current

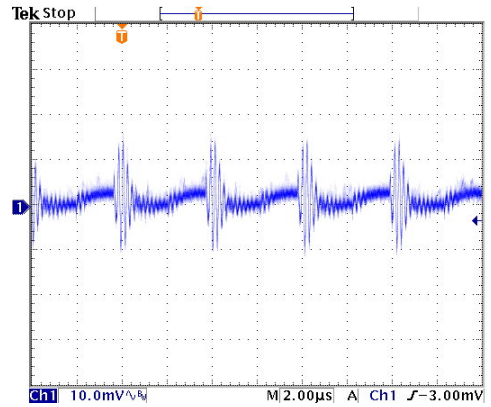

Typical Output Ripple and Noise.

$V_{in} = V_{in,nom}$, Full Load

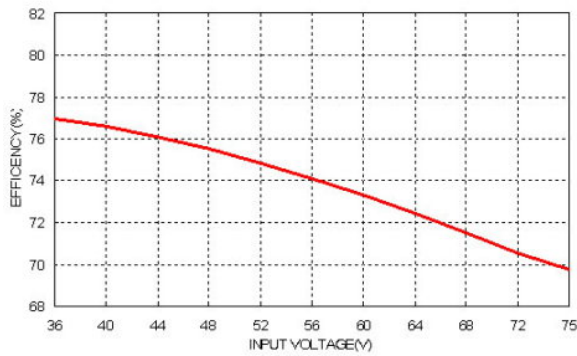

Efficiency versus Input Voltage. Full Load

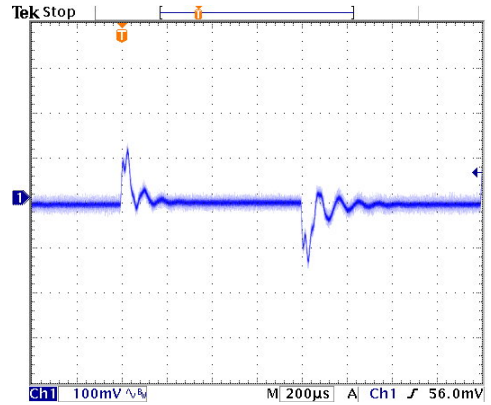

Transient Response to Dynamic Load Change from

100% to 75% to 100% of Full Load ; $V_{in} = V_{in,nom}$

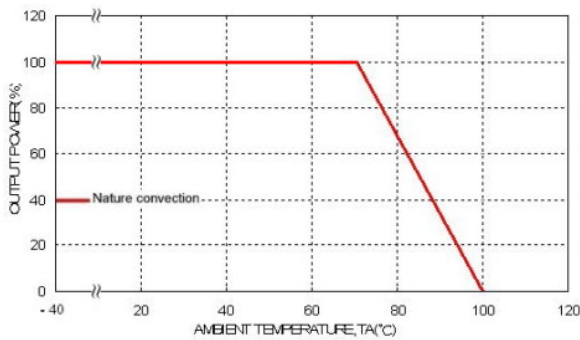

Derating Output Current versus Ambient Temperature and Airflow $V_{in} = V_{in,nom}$

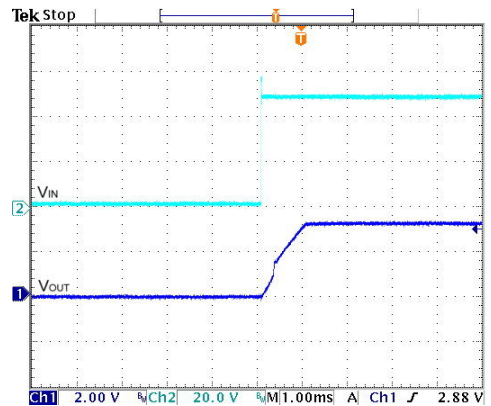

Typical Input Start-Up and Output Rise Characteristic

$V_{in} = V_{in,nom}$, Full Load

Characteristic Curves

All test conditions are at 25°C. The figures are identical for TMR 3-4810 (Continued)

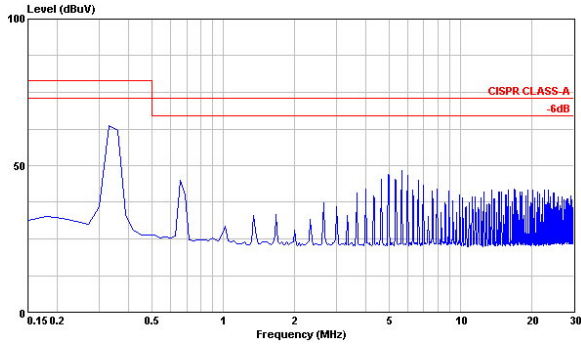

Conduction Emission of EN55022 Class A

$V_{in} = V_{in,nom}$, Full Load

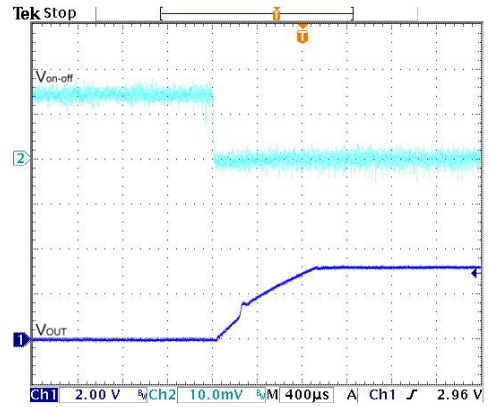

Using ON/OFF Voltage Start-Up and V_{out} Rise Characteristic

$V_{in} = V_{in,nom}$, Full Load

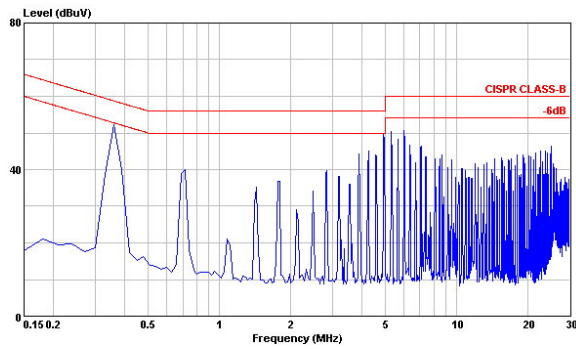

Conduction Emission of EN55022 Class B

$V_{in} = V_{in,nom}$, Full Load

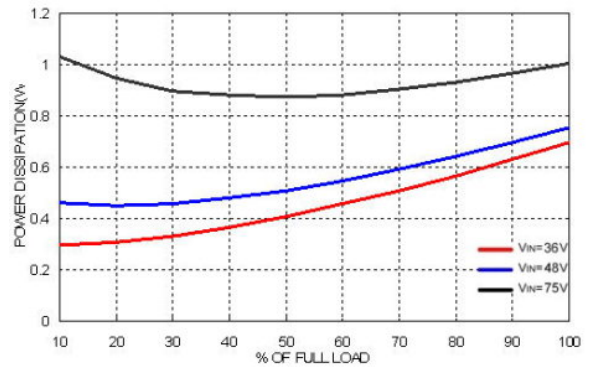

Power Dissipation versus Output Current

Characteristic Curves

All test conditions are at 25°C. The figures are identical for TMR 3-4811

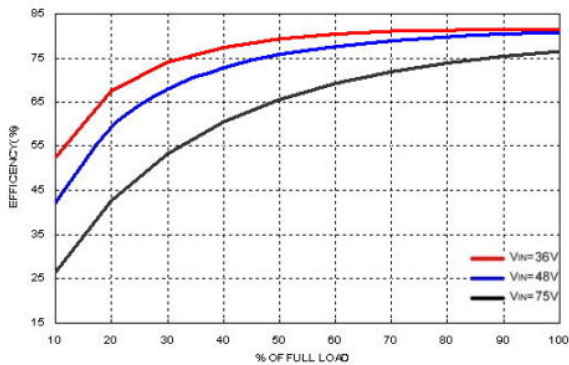

Efficiency versus Output Current

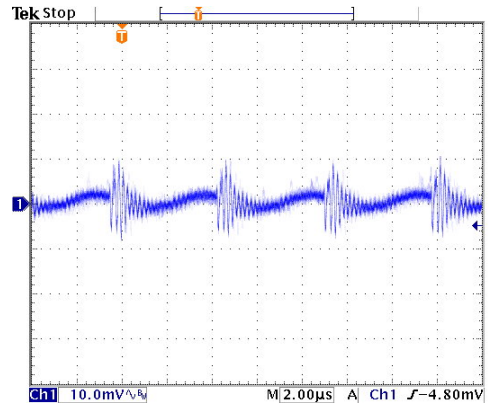

Typical Output Ripple and Noise.

$V_{in} = V_{in,nom}$, Full Load

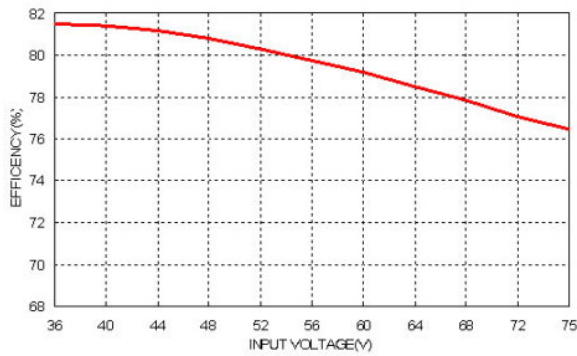

Efficiency versus Input Voltage. Full Load

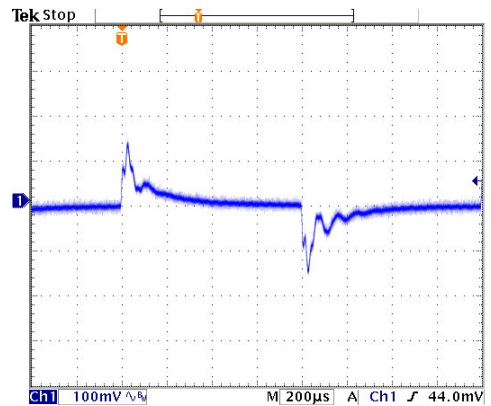

Transient Response to Dynamic Load Change from

100% to 75% to 100% of Full Load ; $V_{in} = V_{in,nom}$

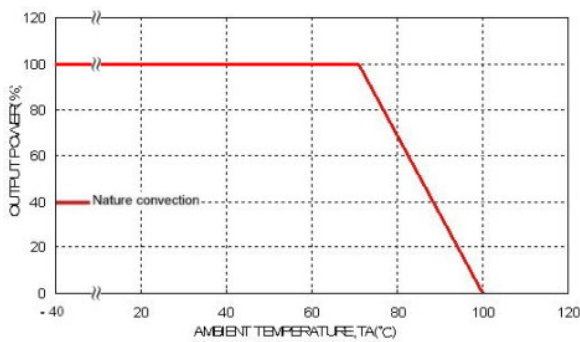

Derating Output Current versus Ambient Temperature and Airflow $V_{in} = V_{in,nom}$

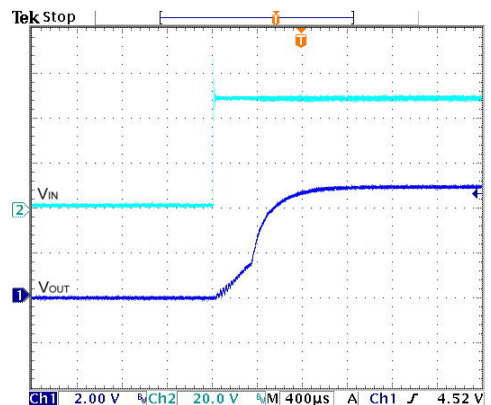

Typical Input Start-Up and Output Rise Characteristic

$V_{in} = V_{in,nom}$, Full Load

Characteristic Curves

All test conditions are at 25°C. The figures are identical for TMR 3-4811 (Continued)

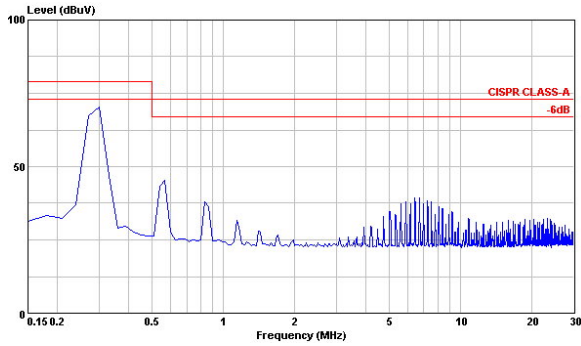

Conduction Emission of EN55022 Class A

$V_{in} = V_{in,nom}$, Full Load

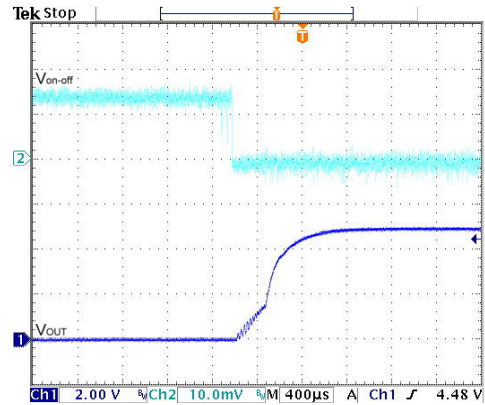

Using ON/OFF Voltage Start-Up and V_{out} Rise Characteristic

$V_{in} = V_{in,nom}$, Full Load

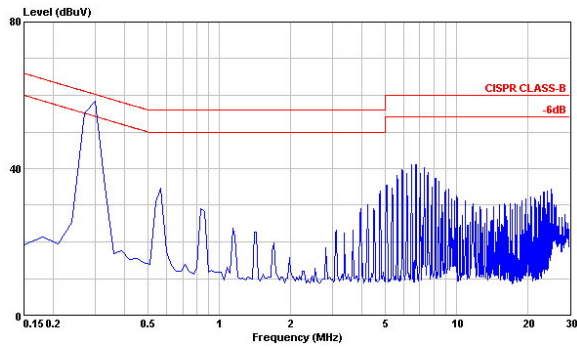

Conduction Emission of EN55022 Class B

$V_{in} = V_{in,nom}$, Full Load

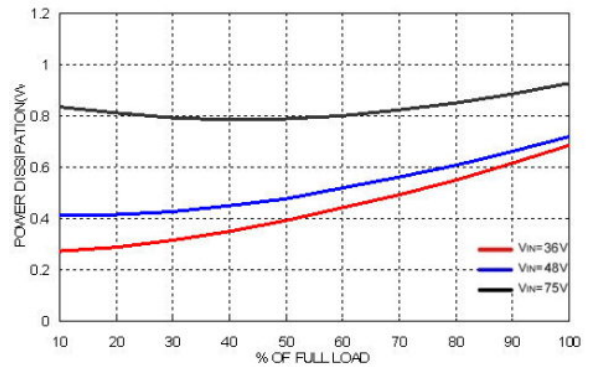

Power Dissipation versus Output Current

Characteristic Curves

All test conditions are at 25°C. The figures are identical for TMR 3-4809

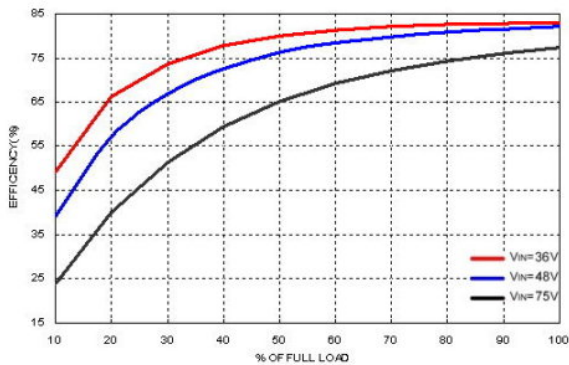

Efficiency versus Output Current

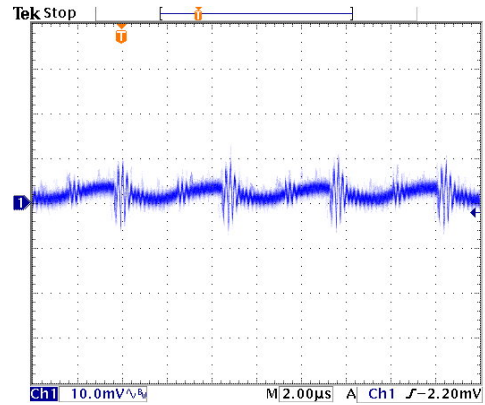

Typical Output Ripple and Noise.

$V_{in} = V_{in,nom}$, Full Load

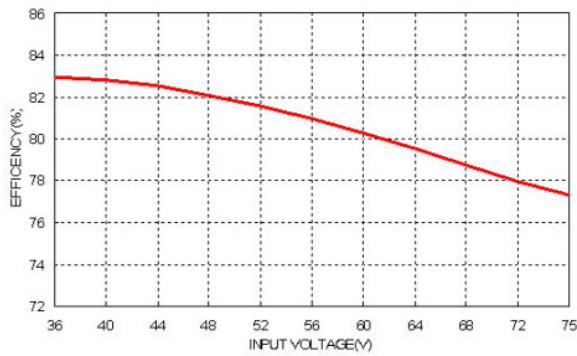

Efficiency versus Input Voltage. Full Load

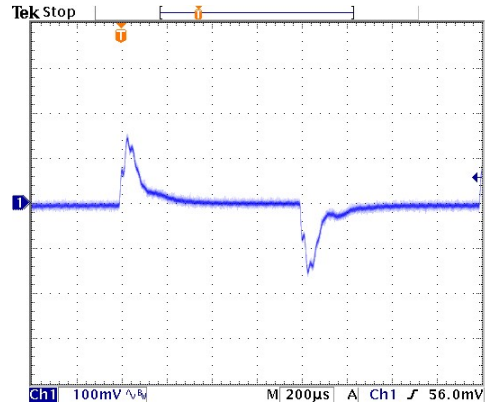

Transient Response to Dynamic Load Change from

100% to 75% to 100% of Full Load ; $V_{in} = V_{in,nom}$

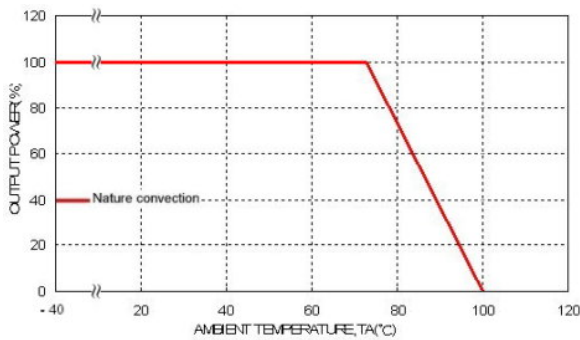

Derating Output Current versus Ambient Temperature and Airflow $V_{in} = V_{in,nom}$

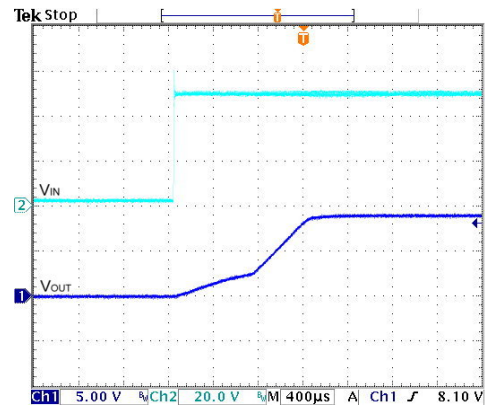

Typical Input Start-Up and Output Rise Characteristic

$V_{in} = V_{in,nom}$, Full Load

Characteristic Curves

All test conditions are at 25°C. The figures are identical for TMR 3-4809 (Continued)

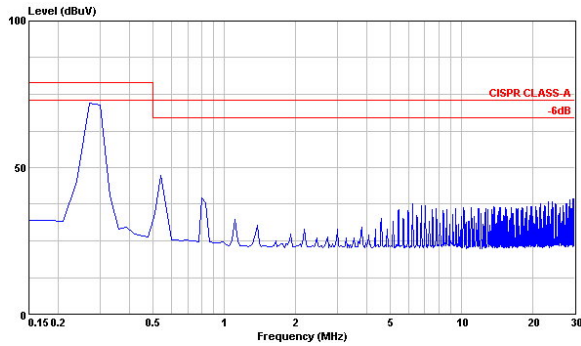

Conduction Emission of EN55022 Class A
 $V_{in} = V_{in,nom}$, Full Load

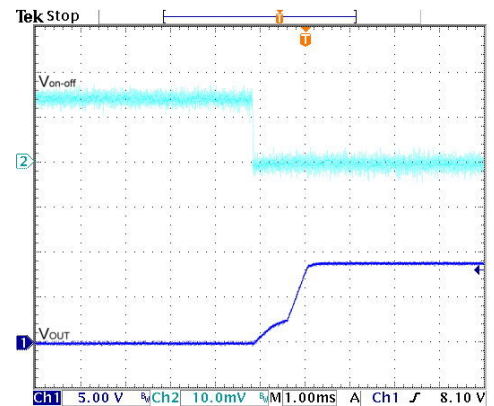

Using ON/OFF Voltage Start-Up and V_{out} Rise Characteristic
 $V_{in} = V_{in,nom}$, Full Load

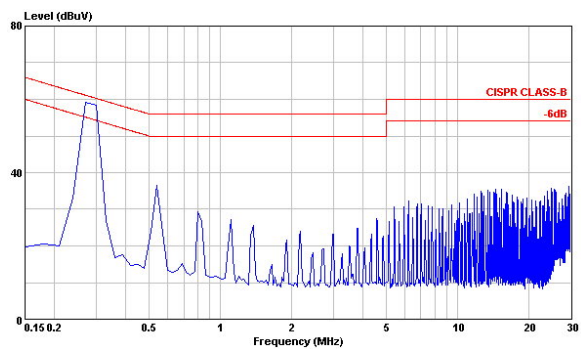

Conduction Emission of EN55022 Class B
 $V_{in} = V_{in,nom}$, Full Load

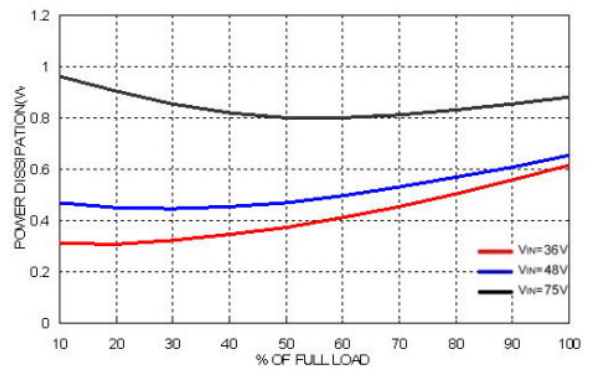

Power Dissipation versus Output Current

Characteristic Curves

All test conditions are at 25°C. The figures are identical for TMR 3-4812

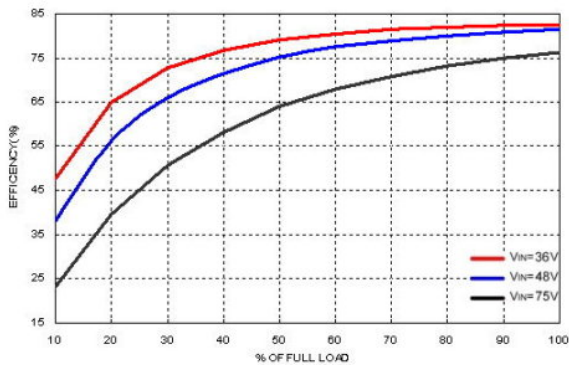

Efficiency versus Output Current

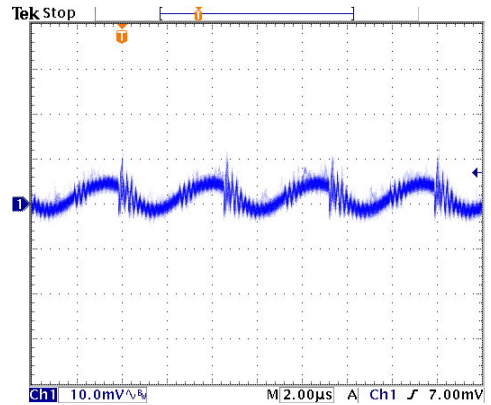

Typical Output Ripple and Noise.

$V_{in} = V_{in,nom}$, Full Load

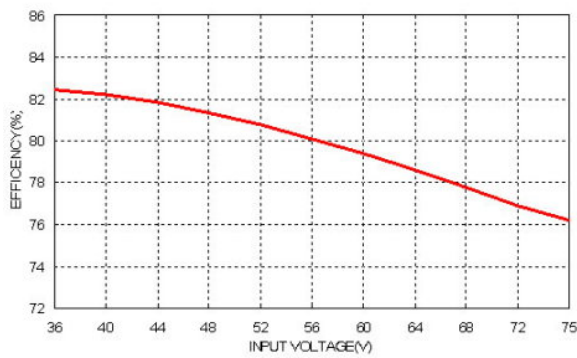

Efficiency versus Input Voltage. Full Load

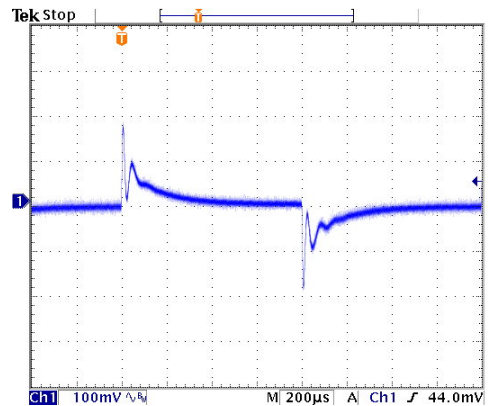

Transient Response to Dynamic Load Change from

100% to 75% to 100% of Full Load ; $V_{in} = V_{in,nom}$

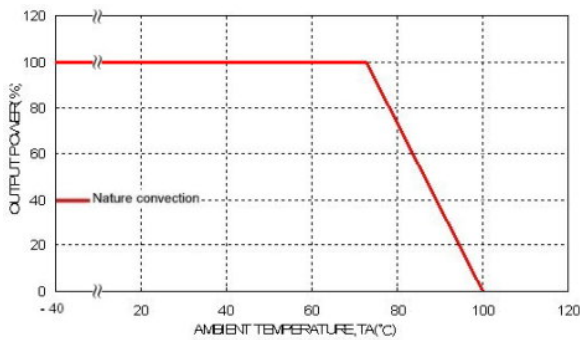

Derating Output Current versus Ambient Temperature and Airflow $V_{in} = V_{in,nom}$

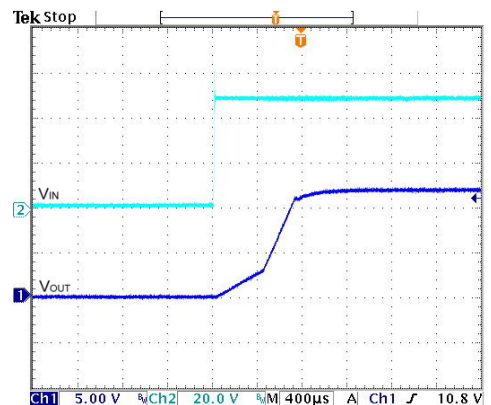

Typical Input Start-Up and Output Rise Characteristic

$V_{in} = V_{in,nom}$, Full Load

Characteristic Curves

All test conditions are at 25°C. The figures are identical for TMR 3-4812 (Continued)

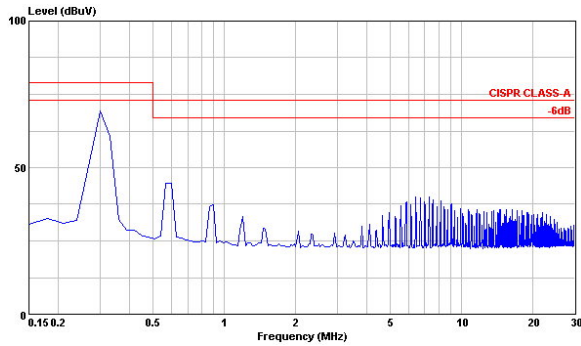

Conduction Emission of EN55022 Class A
 $V_{in} = V_{in,nom}$, Full Load

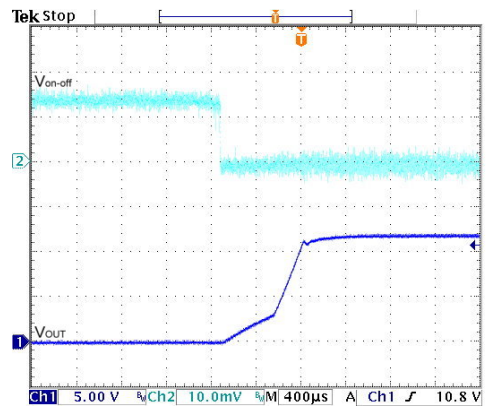

Using ON/OFF Voltage Start-Up and V_{out} Rise Characteristic
 $V_{in} = V_{in,nom}$, Full Load

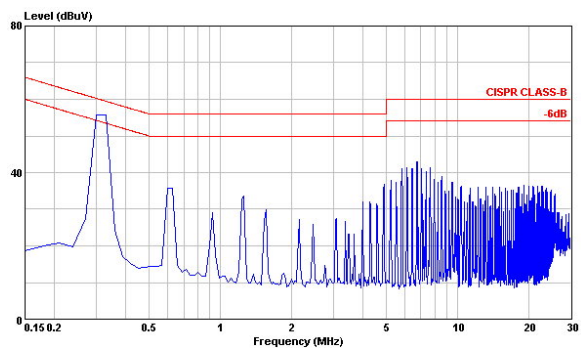

Conduction Emission of EN55022 Class B
 $V_{in} = V_{in,nom}$, Full Load

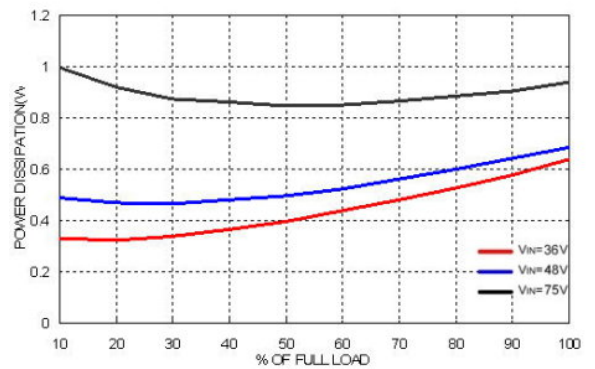

Power Dissipation versus Output Current

Characteristic Curves

All test conditions are at 25°C. The figures are identical for TMR 3-4813

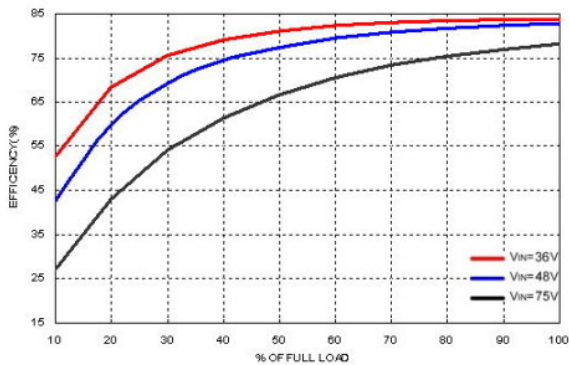

Efficiency versus Output Current

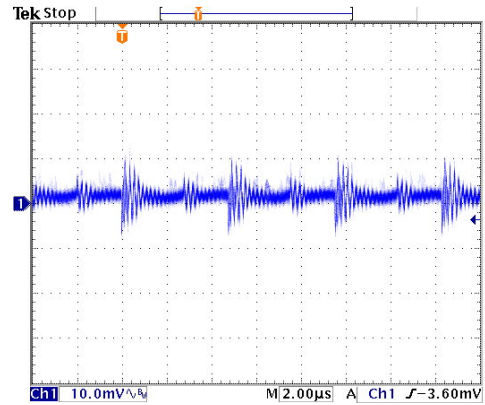

Typical Output Ripple and Noise.

$V_{in} = V_{in,nom}$, Full Load

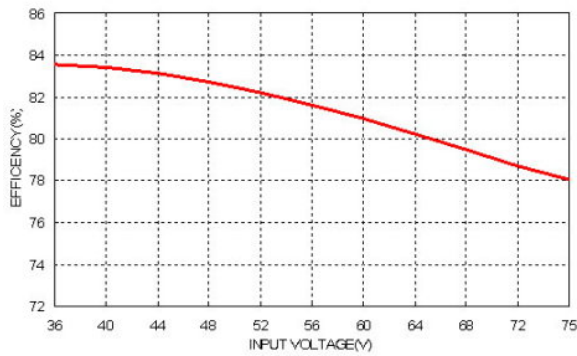

Efficiency versus Input Voltage. Full Load

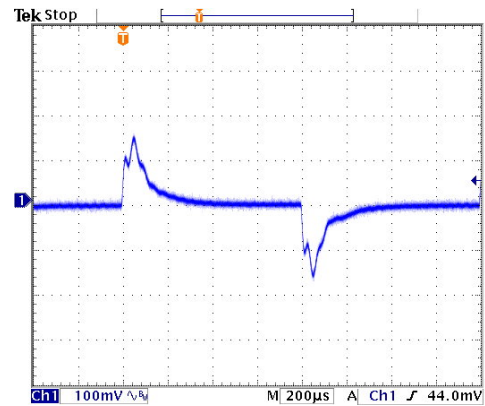

Transient Response to Dynamic Load Change from

100% to 75% to 100% of Full Load ; $V_{in} = V_{in,nom}$

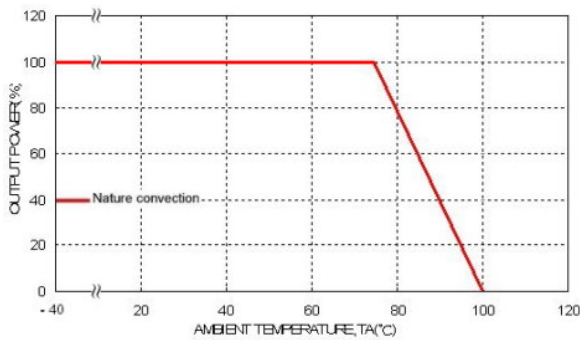

Derating Output Current versus Ambient Temperature and Airflow $V_{in} = V_{in,nom}$

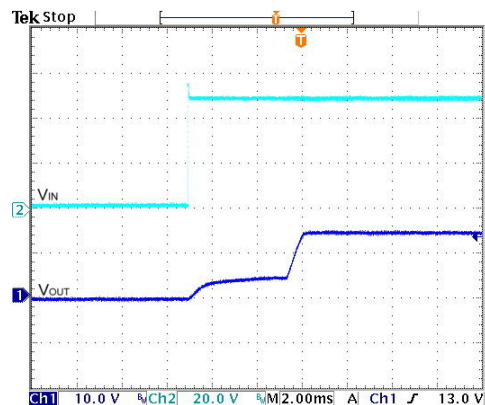

Typical Input Start-Up and Output Rise Characteristic

$V_{in} = V_{in,nom}$, Full Load

Characteristic Curves

All test conditions are at 25°C. The figures are identical for TMR 3-4813 (Continued)

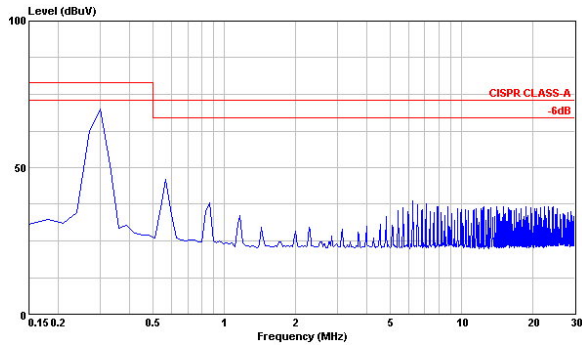

Conduction Emission of EN55022 Class A

$V_{in} = V_{in,nom}$, Full Load

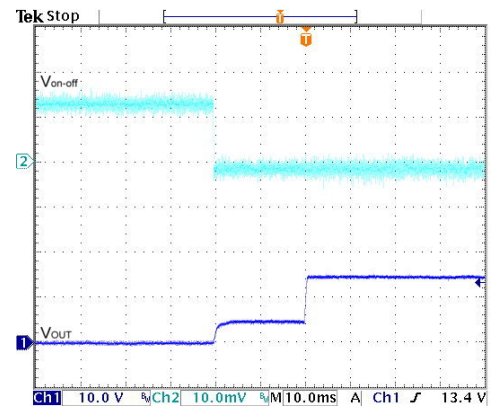

Using ON/OFF Voltage Start-Up and V_{out} Rise Characteristic

$V_{in} = V_{in,nom}$, Full Load

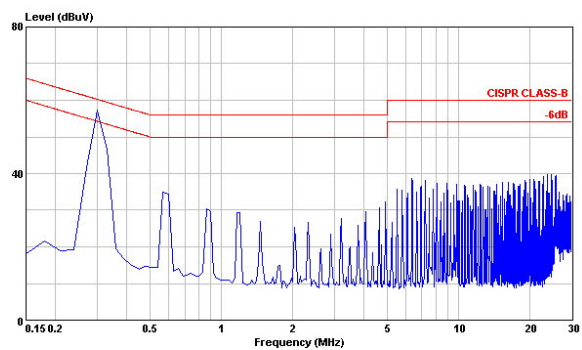

Conduction Emission of EN55022 Class B

$V_{in} = V_{in,nom}$, Full Load

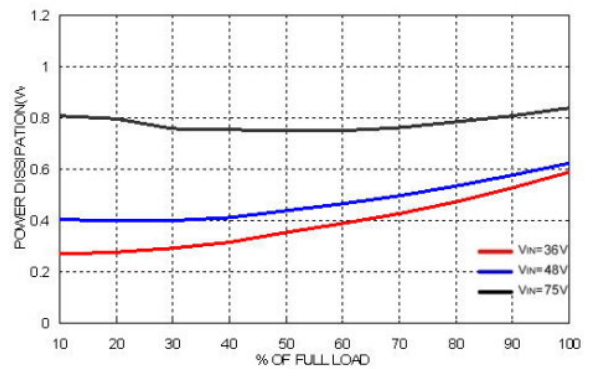

Power Dissipation versus Output Current

Characteristic Curves

All test conditions are at 25°C. The figures are identical for TMR 3-4821

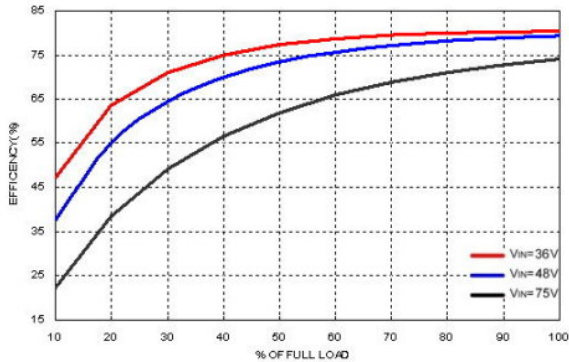

Efficiency versus Output Current

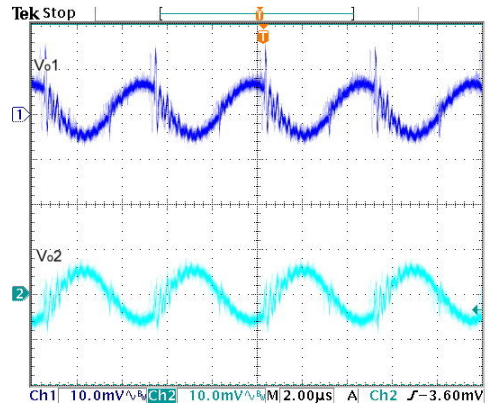

Typical Output Ripple and Noise.

$V_{in} = V_{in,nom}$, Full Load

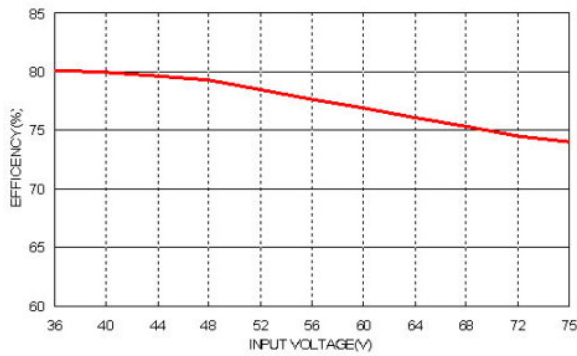

Efficiency versus Input Voltage. Full Load

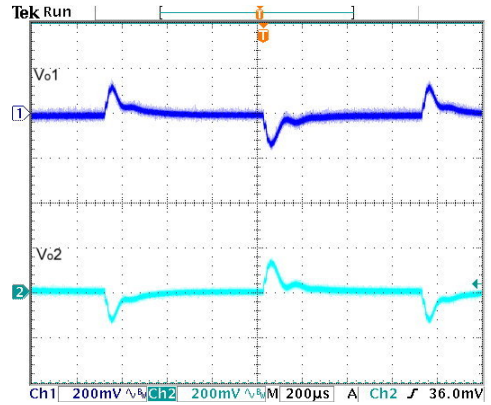

Transient Response to Dynamic Load Change from

100% to 75% to 100% of Full Load ; $V_{in} = V_{in,nom}$

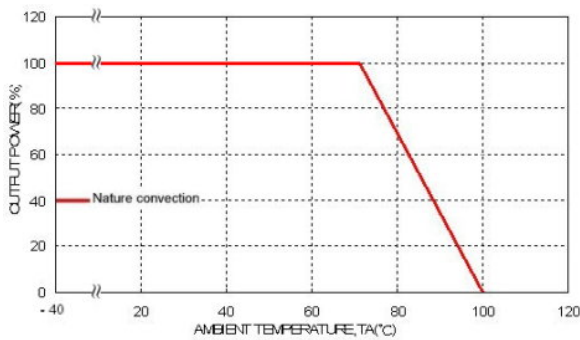

Derating Output Current versus Ambient Temperature and Airflow $V_{in} = V_{in,nom}$

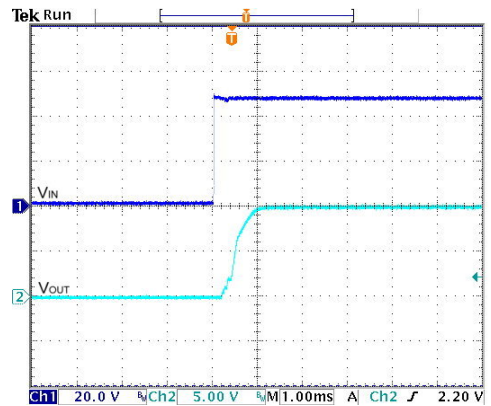

Typical Input Start-Up and Output Rise Characteristic

$V_{in} = V_{in,nom}$, Full Load

Characteristic Curves

All test conditions are at 25°C. The figures are identical for TMR 3-4821 (Continued)

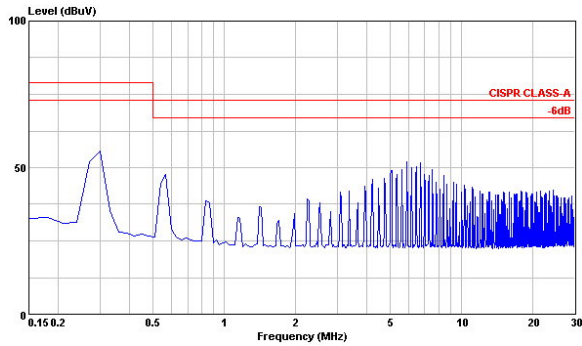

Conduction Emission of EN55022 Class A

$V_{in} = V_{in,nom}$, Full Load

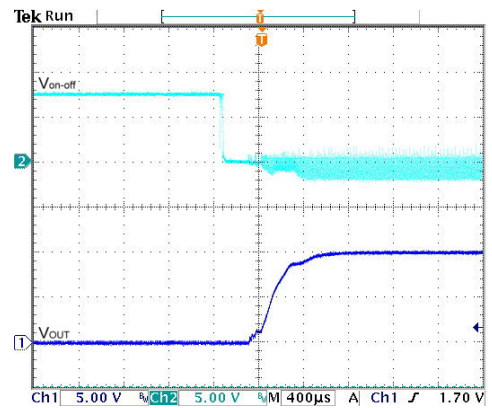

Using ON/OFF Voltage Start-Up and V_{out} Rise Characteristic

$V_{in} = V_{in,nom}$, Full Load

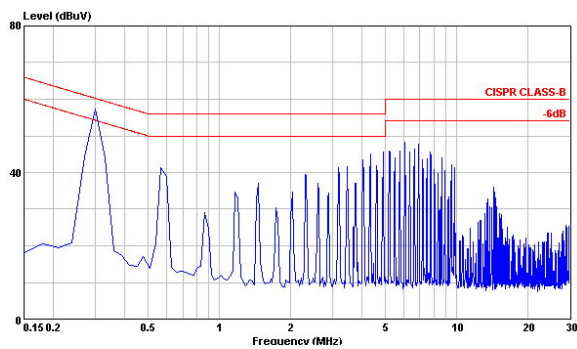

Conduction Emission of EN55022 Class B

$V_{in} = V_{in,nom}$, Full Load

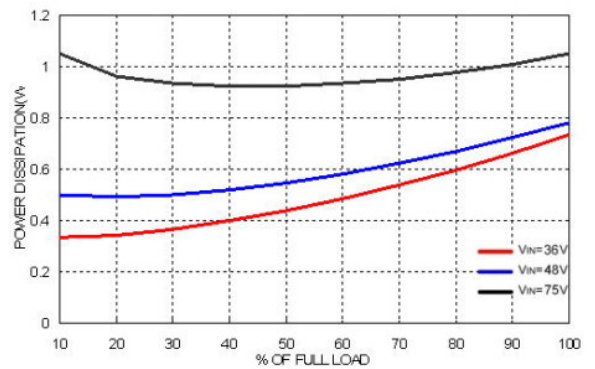

Power Dissipation versus Output Current

Characteristic Curves

All test conditions are at 25°C. The figures are identical for TMR 3-4822

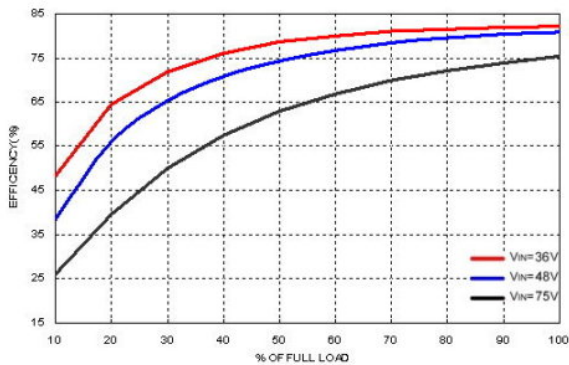

Efficiency versus Output Current

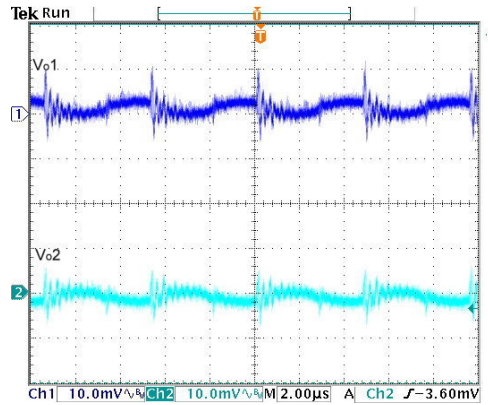

Typical Output Ripple and Noise.

$V_{in} = V_{in,nom}$, Full Load

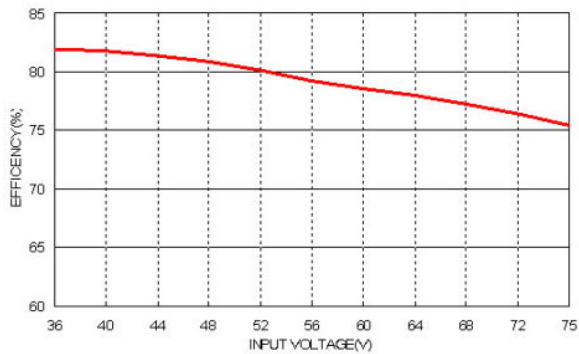

Efficiency versus Input Voltage. Full Load

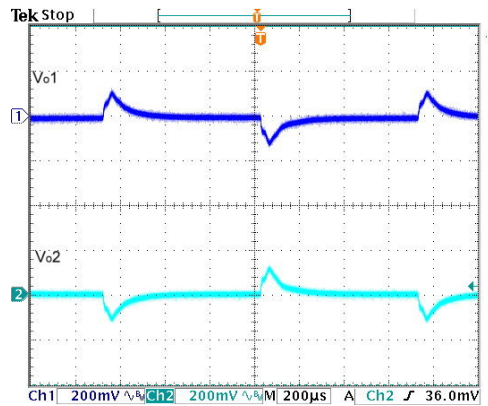

Transient Response to Dynamic Load Change from 100% to 75% to 100% of Full Load ; $V_{in} = V_{in,nom}$

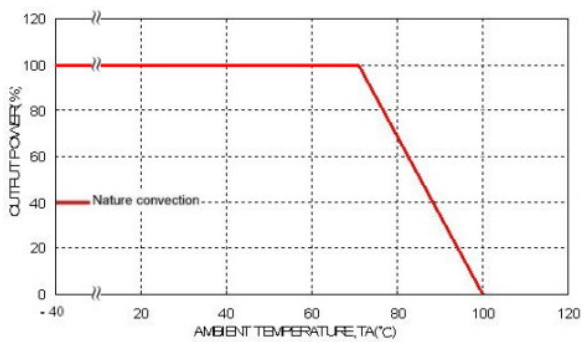

Derating Output Current versus Ambient Temperature and Airflow $V_{in} = V_{in,nom}$

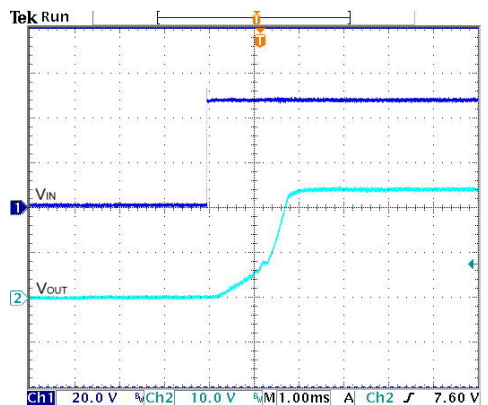

Typical Input Start-Up and Output Rise Characteristic

$V_{in} = V_{in,nom}$, Full Load

Characteristic Curves

All test conditions are at 25°C. The figures are identical for TMR 3-4822 (Continued)

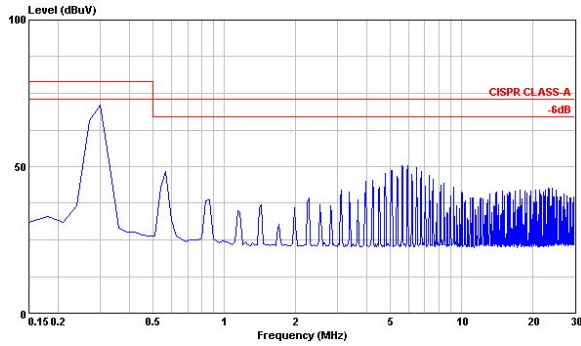

Conduction Emission of EN55022 Class A
 $V_{in} = V_{in,nom}$, Full Load

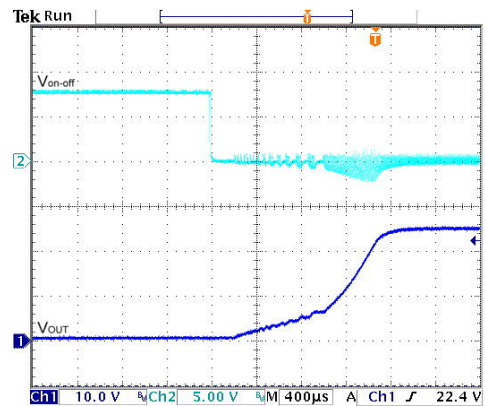

Using ON/OFF Voltage Start-Up and V_{out} Rise Characteristic
 $V_{in} = V_{in,nom}$, Full Load

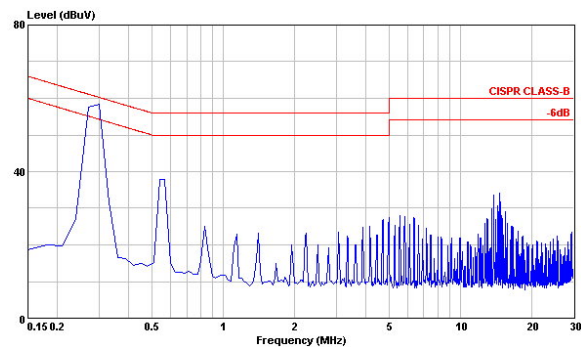

Conduction Emission of EN55022 Class B
 $V_{in} = V_{in,nom}$, Full Load

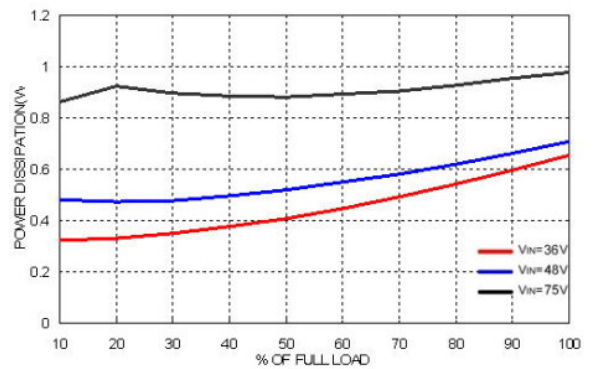

Power Dissipation versus Output Current

Characteristic Curves

All test conditions are at 25°C. The figures are identical for TMR 3-4823

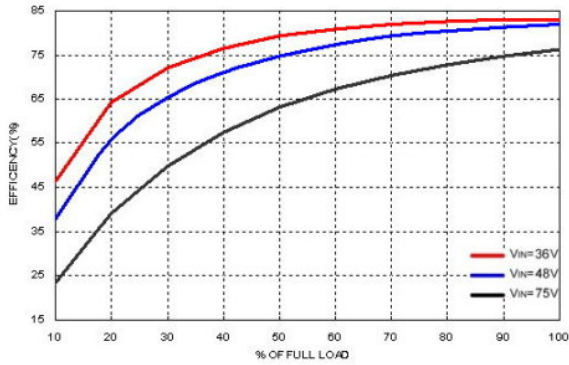

Efficiency versus Output Current

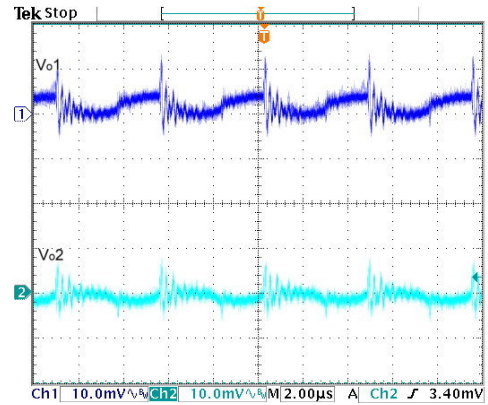

Typical Output Ripple and Noise.

$V_{in} = V_{in,nom}$, Full Load

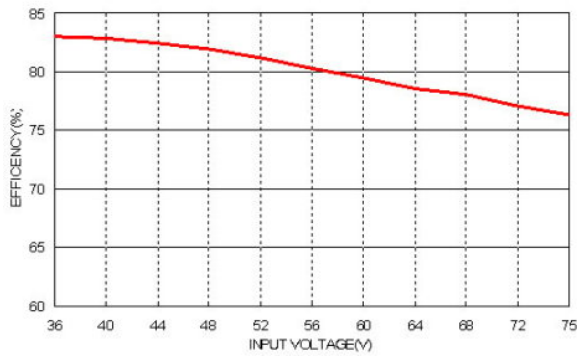

Efficiency versus Input Voltage. Full Load

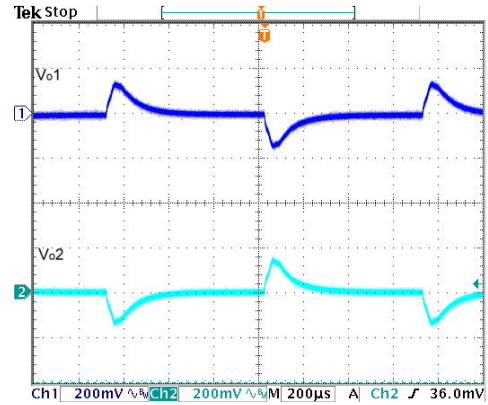

Transient Response to Dynamic Load Change from

100% to 75% to 100% of Full Load ; $V_{in} = V_{in,nom}$

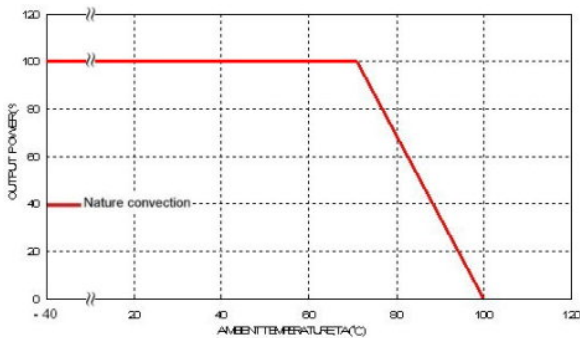

Derating Output Current versus Ambient Temperature and Airflow $V_{in} = V_{in,nom}$

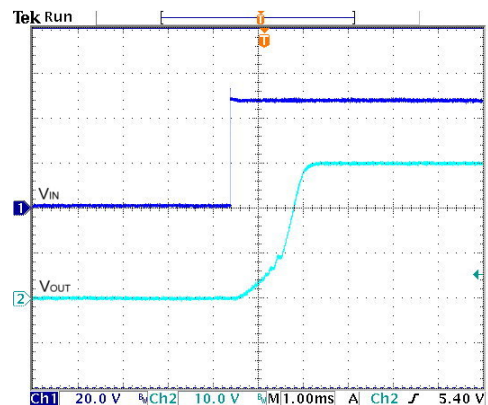

Typical Input Start-Up and Output Rise Characteristic

$V_{in} = V_{in,nom}$, Full Load

Characteristic Curves

All test conditions are at 25°C. The figures are identical for TMR 3-4823 (Continued)

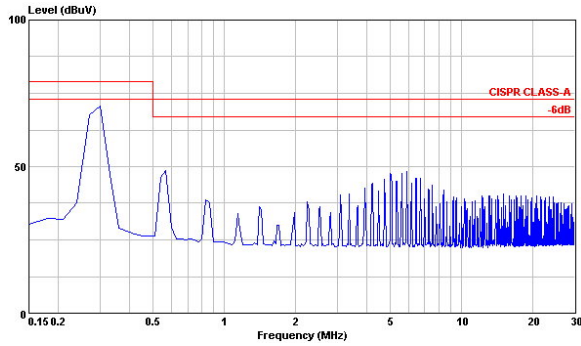

Conduction Emission of EN55022 Class A

$V_{in} = V_{in,nom}$, Full Load

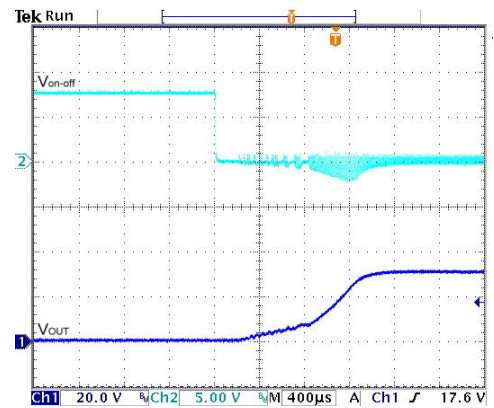

Using ON/OFF Voltage Start-Up and V_{out} Rise Characteristic

$V_{in} = V_{in,nom}$, Full Load

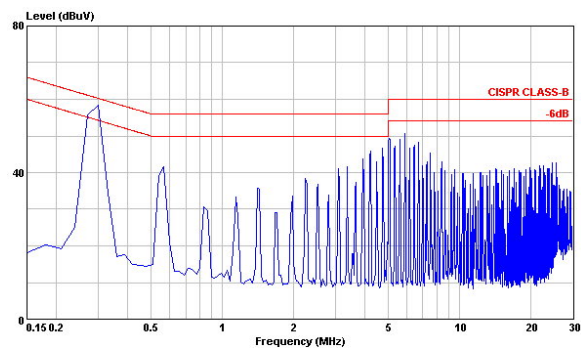

Conduction Emission of EN55022 Class B

$V_{in} = V_{in,nom}$, Full Load

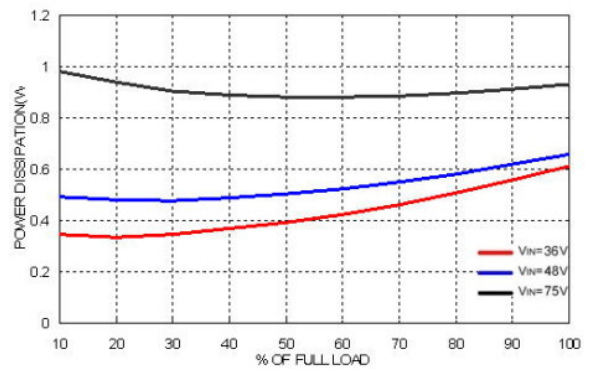

Power Dissipation versus Output Current

Test Configurations

Input reflected-ripple current measurement test up

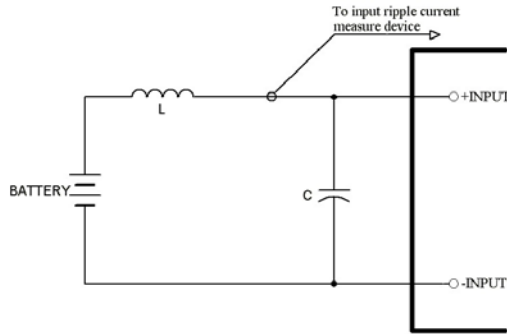

Component	Value	Voltage	Reference
L	12μH	---	---
C	1μF	100V	1210 MLCC

Peak-to-peak output ripple & noise measurement test up

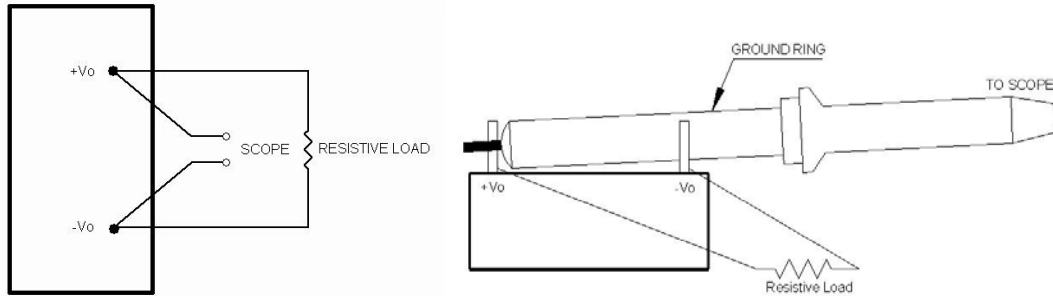

Output voltage and efficiency measurement test up

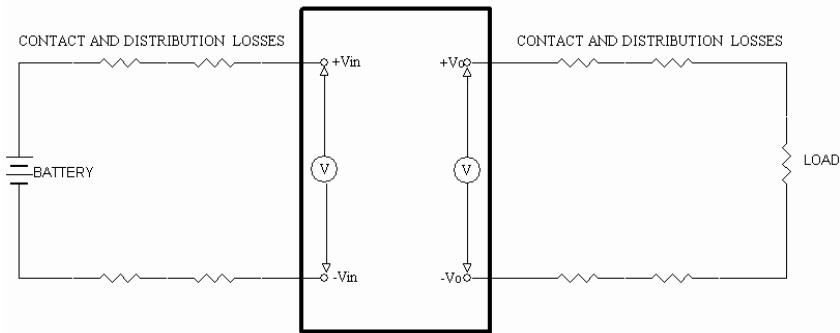

Note: All measurements have to be taken at the module terminals.

$$Efficiency = \left(\frac{V_o \times I_o}{V_{in} \times I_{in}} \right) \times 100\%$$

EMC considerations

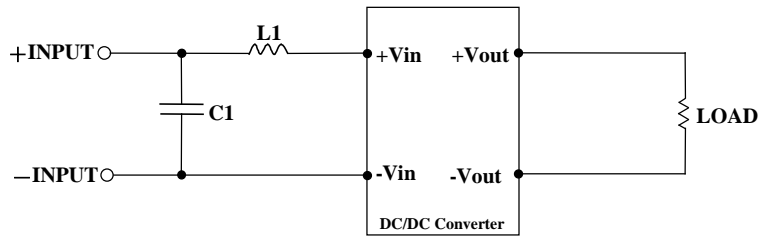

Suggested Schematic to comply with EN55022 Class A Conducted Noise

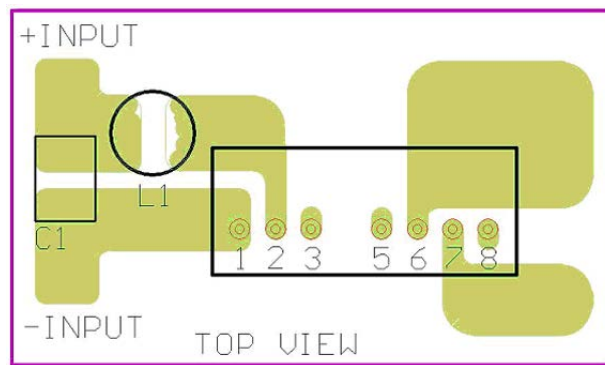

recommended Layout with Input Filter

Following components are needed to comply with EN55022 Class A conducted noise:

TMR 3-05xx

Component	Value	Ratings	Reference
C1	2.2µF	10V	1206 MLCC
L1	3.3µH	2.0A / 0.06Ω / 0504	SMD Inductor, P/N: TCK-044

TMR 3-12xx

Component	Value	Ratings	Reference
C1	0.68µF	25V	1206 MLCC
L1	10µH	1.4A / 0.1 Ω / 0504	SMD Inductor, P/N: TCK-047

TMR 3-24xx

Component	Value	Ratings	Reference
C1	4.7µF	50V	1812 MLCC
L1	10µH	1.4A / 0.1 Ω / 0504	SMD Inductor, P/N: TCK-047

TMR 3-48xx

Component	Value	Ratings	Reference
C1	0.47µF	100V	1812 MLCC
L1	56µH	0.7A / 0.4 Ω / 0504	SMD Inductor, P/N: TCK-045

EMC considerations (Continued)

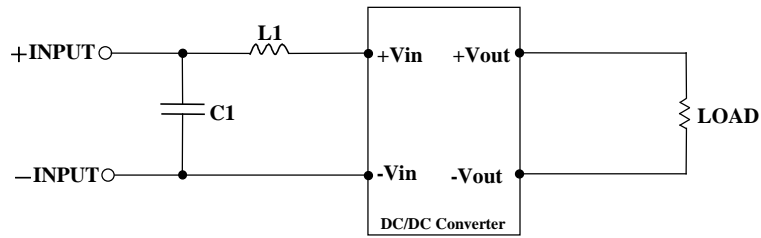

Suggested Schematic to comply with EN55022 Class B Conducted Noise

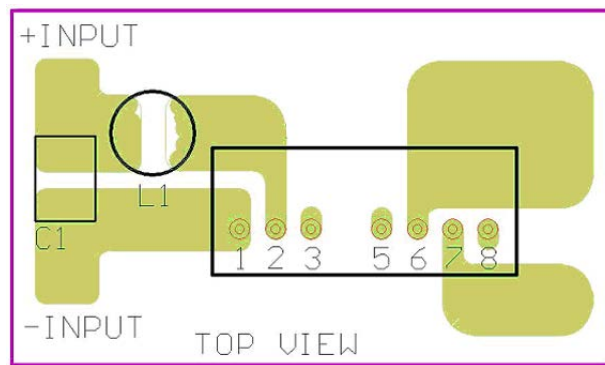

recommended Layout with Input Filter

Following components are needed to comply with EN55022 Class B conducted noise:

TMR 3-05xx

Component	Value	Voltage	Reference
C1	10 μ F	10V	1206 MLCC
L1	3.3 μ H	2.0A / 0.06 Ω / 0504	SMD Inductor, P/N: TCK-044

TMR 3-12xx

Component	Value	Voltage	Reference
C1	2.2 μ F	25V	1206 MLCC
L1	18 μ H	1.2A / 0.15 Ω / 0504	SMD Inductor, P/N: TCK-046

TMR 3-24xx

Component	Value	Voltage	Reference
C1	10 μ F	50V	1812 MLCC
L1	10 μ H	1.4A / 0.1 Ω / 0504	SMD Inductor, P/N: TCK-047

TMR 3-48xx

Component	Value	Ratings	Reference
C1	2.2 μ F	100V	1812 MLCC
L1	56 μ H	0.7A / 0.4 Ω / 0504	SMD Inductor, P/N: TCK-045

Input Source Impedance

The power module should be connected to a low impedance input source. Highly inductive source impedance can affect the stability of the power module. Input external L-C filter is recommended to minimize input reflected ripple current. The capacitor should be equipped as close as possible to the input terminals of the TMR 3 converter for lower impedance.

Thermal Consideration

The TMR 3 converter operates in a variety of thermal environments. However, sufficient cooling should be provided to ensure reliable performance of the unit. Heat is removed by conduction, convection, and radiation to the surrounding environment. Proper cooling can be verified by measuring the point as shown at the figure below. The temperature at this point shall not exceed 100°C. When operating, adequate cooling must be provided to maintain the test point temperature at or below 100°C. Although the maximum point temperature of the TMR 3 converter is 100°C, you can limit this temperature to a lower value for higher reliability.

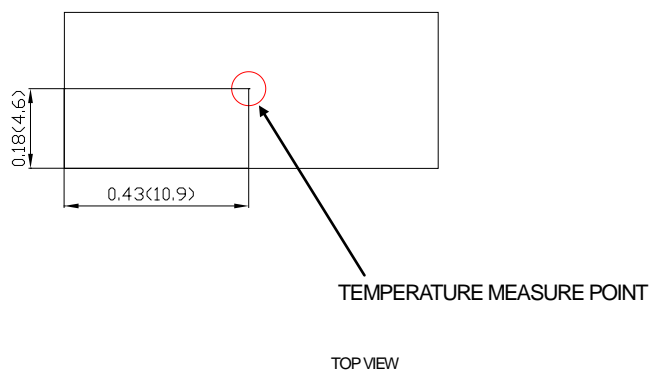

Measurement shown in inches and (millimeters)

Remote ON/OFF Control

The positive logic remote ON/OFF control circuit is included. Turns the module ON during a logic High on the On/Off pin and turns OFF during a logic Low. The On/Off pin is an open collector/drain logic input signal (Von/off) that referenced to -Vin (GND). If the remote on/off feature is not used, keep open circuit between on/off pin and -Vin pin to turn the module on.

Remote ON/OFF Implementation

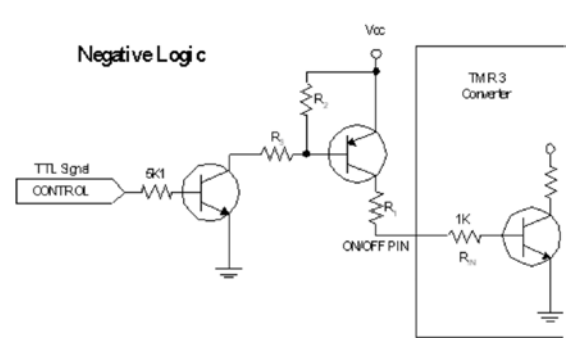
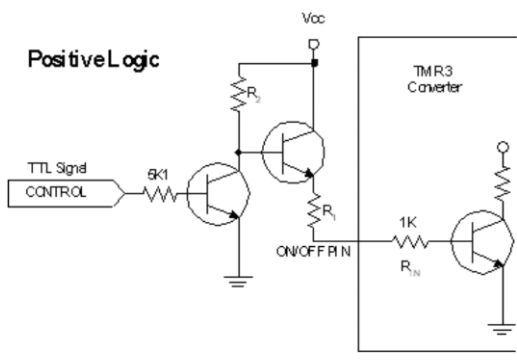

Positive Logic	R1 (K Ω)	R2 (K Ω)
Vcc = 4.5 - 9.0Vdc	0.0	7.5
Vcc = 9.0 - 18Vdc	2.2	16
Vcc = 18 - 36Vdc	6.8	33
Vcc = 36 - 75Vdc	15	68

Negative Logic	R1 (K Ω)	R2 (K Ω)	R3 (K Ω)
Vcc = 4.5 - 9.0Vdc	0.36	5.1	7.5
Vcc = 9.0 - 18Vdc	2.7	5.1	16
Vcc = 18 - 36Vdc	7.5	5.1	33
Vcc = 36 - 75Vdc	16	5.1	68

Mechanical Data

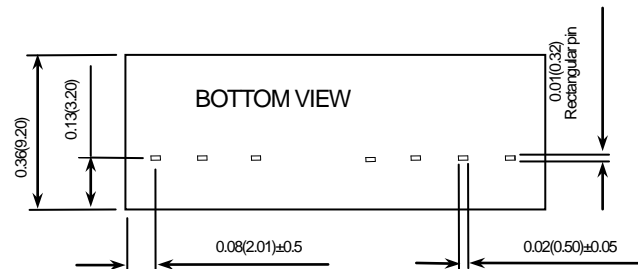
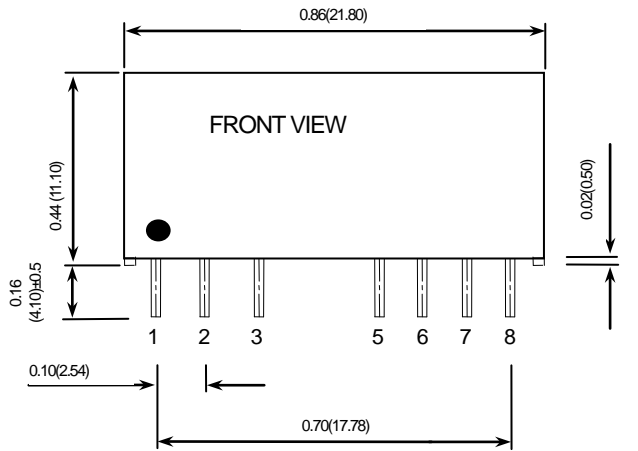

All Dimensions in INCHES (mm)
 Tolerance: X.XX ±0.02 (X.X ±0.5mm)
 X.XXX ±0.01 (X.XX ±0.25mm)

Pin Pitch Tolerance ±0.02 (±0.5mm)

Pin Connection		
Pin	Single Output	Dual Output
1	- Vin (GND)	- Vin (GND)
2	+Vin (Vcc)	+Vin (Vcc)
3	CTRL	CTRL
5	NC	NC
6	+Vout	+Vout
7	-Vout	Com
8	NC	-Vout

Recommended Pad Layout

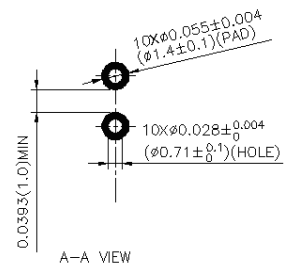
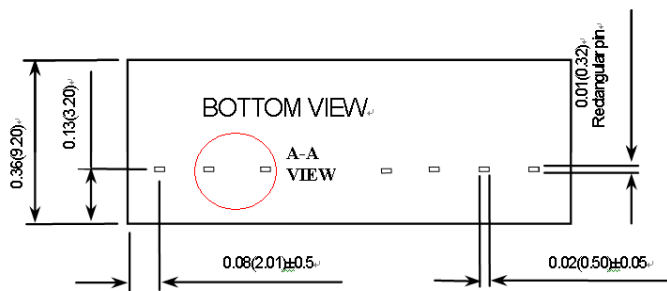

All Dimensions in INCHES (mm)
 Tolerance: X.XX ±0.02 (X.X ±0.5mm)
 X.XXX ±0.01 (X.XX ±0.25mm)

Pin Pitch Tolerance ±0.02 (±0.5mm)

Soldering and Reflow Considerations

Lead free wave solder profile for TMR 3 DIP type

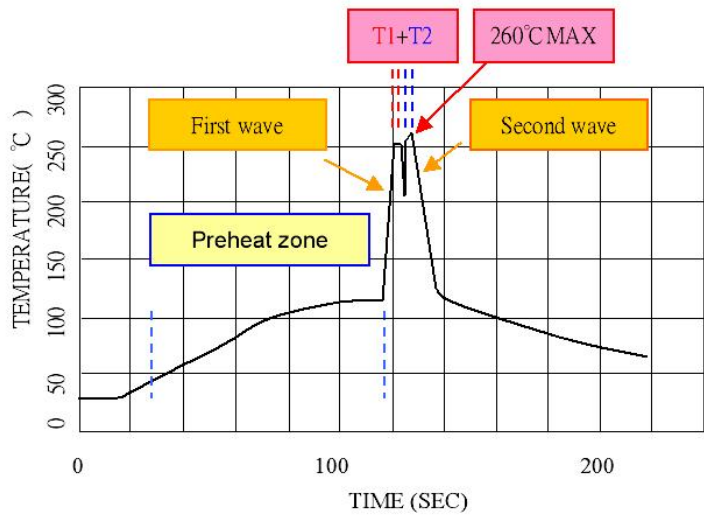

Zone	Reference Parameter
Preheat zone	Rise temp. speed : 3°C/ sec max. Preheat temp. : 100~130°C
Actual heating	Peak temp. : 250~260°C Peak time (T1+T2 time) : 4~6 sec

Reference Solder : Sn-Ag-Cu ; Sn-Cu

Hand Soldering :

- Soldering iron : Power 90W
- Welding Time : 2~4 sec
- Temp. : 380~400°C

Packaging Information

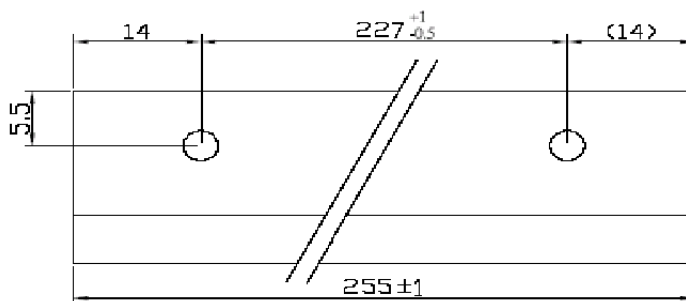
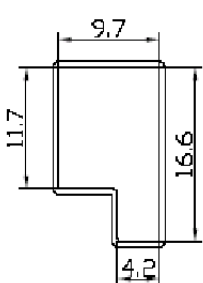

10 PCS per TUBE

Part Number Structure

TMR 3 - 4811

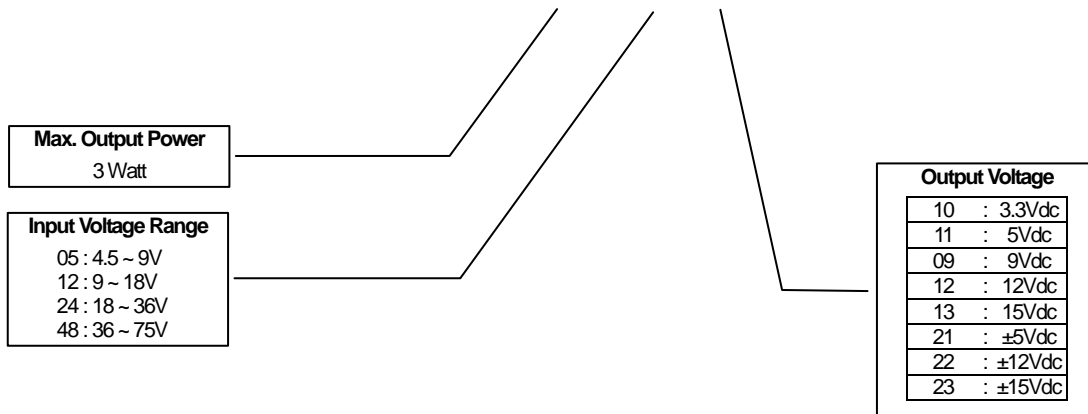

Model Number	Input Range	Output Voltage	Output Current	Input Current	Efficiency ⁽²⁾ (%)
			Full Load	Full Load ⁽¹⁾	
TMR 3-0510	4.5 – 9 VDC	3.3 VDC	700mA	650mA	75
TMR 3-0511	4.5 – 9 VDC	5 VDC	600mA	800mA	79
TMR 3-0509	4.5 – 9 VDC	9 VDC	333mA	789mA	80
TMR 3-0512	4.5 – 9 VDC	12 VDC	250mA	779mA	81
TMR 3-0513	4.5 – 9 VDC	15 VDC	200mA	769mA	82
TMR 3-0521	4.5 – 9 VDC	±5 VDC	±300mA	810mA	78
TMR 3-0522	4.5 – 9 VDC	±12 VDC	±125mA	779mA	81
TMR 3-0523	4.5 – 9 VDC	±15 VDC	±100mA	779mA	81
TMR 3-1210	9 – 18 VDC	3.3 VDC	700mA	263mA	77
TMR 3-1211	9 – 18 VDC	5 VDC	600mA	325mA	81
TMR 3-1209	9 – 18 VDC	9 VDC	333mA	329mA	80
TMR 3-1212	9 – 18 VDC	12 VDC	250mA	316mA	83
TMR 3-1213	9 – 18 VDC	15 VDC	200mA	316mA	83
TMR 3-1221	9 – 18 VDC	±5 VDC	±300mA	320mA	82
TMR 3-1222	9 – 18 VDC	±12 VDC	±125mA	316mA	83
TMR 3-1223	9 – 18 VDC	±15 VDC	±100mA	316mA	83
TMR 3-2410	18 – 36 VDC	3.3 VDC	700mA	134mA	76
TMR 3-2411	18 – 36 VDC	5 VDC	600mA	160mA	82
TMR 3-2409	18 – 36 VDC	9 VDC	333mA	160mA	82
TMR 3-2412	18 – 36 VDC	12 VDC	250mA	158mA	83
TMR 3-2413	18 – 36 VDC	15 VDC	200mA	156mA	84
TMR 3-2421	18 – 36 VDC	±5 VDC	±300mA	164mA	80
TMR 3-2422	18 – 36 VDC	±12 VDC	±125mA	158mA	83
TMR 3-2423	18 – 36 VDC	±15 VDC	±100mA	154mA	85
TMR 3-4810	36 – 75 VDC	3.3 VDC	700mA	69mA	74
TMR 3-4811	36 – 75 VDC	5 VDC	600mA	83mA	79
TMR 3-4809	36 – 75 VDC	9 VDC	333mA	82mA	80
TMR 3-4812	36 – 75 VDC	12 VDC	250mA	81mA	81
TMR 3-4813	36 – 75 VDC	15 VDC	200mA	80mA	82
TMR 3-4821	36 – 75 VDC	±5 VDC	±300mA	83mA	79
TMR 3-4822	36 – 75 VDC	±12 VDC	±125mA	80mA	82
TMR 3-4823	36 – 75 VDC	±15 VDC	±100mA	79mA	83

Note 1. Maximum value at nominal input voltage and full load of standard type.

Note 2. Typical value at nominal input voltage and full load.

Safety and Installation Instruction

Fusing Consideration

Caution: This power module is not internally fused. An input line fuse must always be used.

This encapsulated TMR 3 converter can be used in a wide variety of applications, ranging from simple stand-alone operation to an integrated part of sophisticated power architecture. To maximum flexibility, internal fusing is not included; however, to achieve maximum safety and system protection, always use an input line fuse. The safety agencies require a normal-blow fuse with maximum rating of 3A for TMR 3-05xx and TMR 3-12xx modules, 1.5A for TMR 3-24xx and TMR 3-48xx modules. Based on the information provided in this data sheet on Inrush energy and maximum dc input current; the same type of fuse with lower rating can be used. Refer to the fuse manufacturer's data for further information.

MTBF and Reliability

The MTBF of TMR 3 series DC/DC converters has been calculated according to

Bellcore TR-NWT-000332 Case I: 50% stress, operating temperature at 40°C (Ground fixed and controlled environment). The resulting figure for MTBF is: 4.386×10^6 hours.

MIL-HDBK 217F NOTICE2 FULL LOAD, operating temperature at 25°C. The resulting figure for MTBF is: 2.401×10^6 hours.