

DATA SHEET

RM7/I RM cores and accessories

Product specification
File under Magnetic Products, MA01

1997 Nov 21

RM cores and accessories

RM7/I

CORE SETS

Effective core parameters

SYMBOL	PARAMETER	VALUE	UNIT
$\Sigma(I/A)$	core factor (C1)	0.680	mm ⁻¹
V_e	effective volume	1325	mm ³
l_e	effective length	30.0	mm
A_e	effective area	44.1	mm ²
A_{min}	minimum area	39.6	mm ²
m	mass of set	≈7.7	g

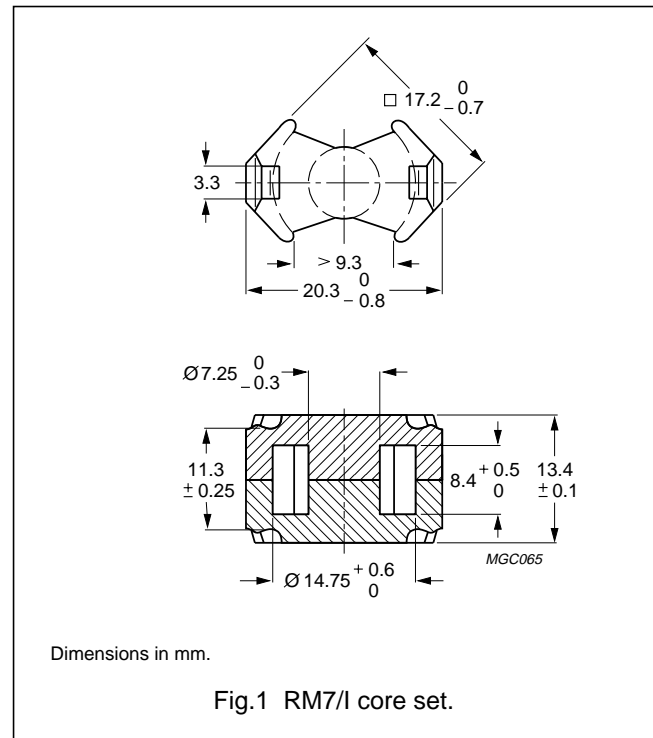

Core sets for general purpose transformers and power applications

Clamping force 40 ±20 N.

GRADE	A_L (nH)	μ_e	AIR GAP (μm)	TYPE NUMBER
3B8 ^{sup}	160 ±3%	≈89	≈400	RM7/I-3B8-A160
	250 ±3%	≈139	≈200	RM7/I-3B8-A250
	3000 ±25%	≈1670	≈0	RM7/I-3B8
3C85 ^{sup}	100 ±3%	≈56	≈800	RM7/I-3C85-A100
	160 ±3%	≈89	≈400	RM7/I-3C85-A160
	250 ±3%	≈139	≈200	RM7/I-3C85-A250
	2700 ±25%	≈1500	≈0	RM7/I-3C85
3C90 ^{sup}	2700 ±25%	≈1500	≈0	RM7/I-3C90
3F3 ^{sup}	100 ±3%	≈56	≈800	RM7/I-3F3-A100
	160 ±3%	≈89	≈400	RM7/I-3F3-A160
	250 ±3%	≈139	≈200	RM7/I-3F3-A250
	2500 ±25%	≈1390	≈0	RM7/I-3F3

RM cores and accessories

RM7/I

Core sets of high permeability grades

Clamping force 25 ± 10 N.

GRADE	A_L (nH)	μ_e	TYPE NUMBER
3E1 ^{sup}	$4750 \pm 25\%$	≈ 2570	RM7/I-3E1
3E4 ^{sup}	$6600 +40/-30\%$	≈ 3590	RM7/I-3E4
3E5 ^{sup}	$10000 +40/-30\%$	≈ 5370	RM7/I-3E5

Properties of core sets under power conditions

GRADE	B (mT) at	CORE LOSS (W) at		
	H = 250 A/m; f = 25 kHz; T = 100 °C	f = 25 kHz; \hat{B} = 200 mT; T = 100 °C	f = 100 kHz; \hat{B} = 100 mT; T = 100 °C	f = 400 kHz; \hat{B} = 50 mT; T = 100 °C
3B8	≥ 315	≤ 0.40	–	–
3C85	≥ 315	≤ 0.20	≤ 0.24	–
3C90	≥ 315	≤ 0.15	≤ 0.15	–
3F3	≥ 315	–	≤ 0.15	≤ 0.25

COIL FORMER

General data

PARAMETER	SPECIFICATION
Coil former material	phenolformaldehyde (PF), glass-reinforced, flame retardant in accordance with UL 94V-0; UL file number E167521(M)
Pin material	copper-tin alloy (CuSn), tin-lead alloy (SnPb) plated
Maximum operating temperature	180 °C, IEC 85 class H
Resistance to soldering heat	"IEC 68-2-20", Part 2, Test Tb, method 1B, 350 °C, 3.5 s
Solderability	"IEC 68-2-20", Part 2, Test Ta, method 1

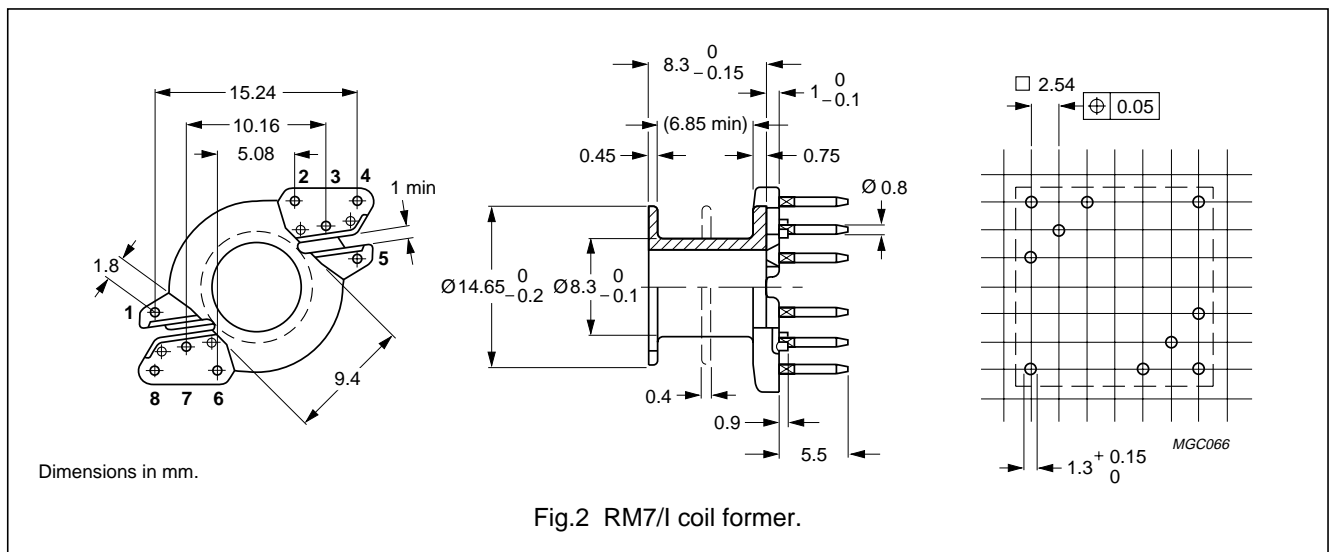

RM cores and accessories

RM7/I

Winding data for RM7/I coil former

NUMBER OF SECTIONS	NUMBER OF PINS	PIN POSITIONS USED	AVERAGE LENGTH OF TURN (mm)	WINDING AREA (mm ²)	WINDING WIDTH (mm)	TYPE NUMBER
1	4	1, 2, 5, 6	35	21	6.85	CSV-RM7-1S-4P
1	8	all	35	21	6.85	CSV-RM7-1S-8P
2	8	all	35	2 × 9.8	2 × 3.2	CSV-RM7-2S-8P

MOUNTING PARTS

General data

ITEM	SPECIFICATION
Clamping force	≈20 N
Clip material	steel
Clip plating	tin-lead alloy (SnPb)
Solderability	"IEC 68-2-20", Part 2, Test Ta, method 1
Type number	CLI/P-RM7

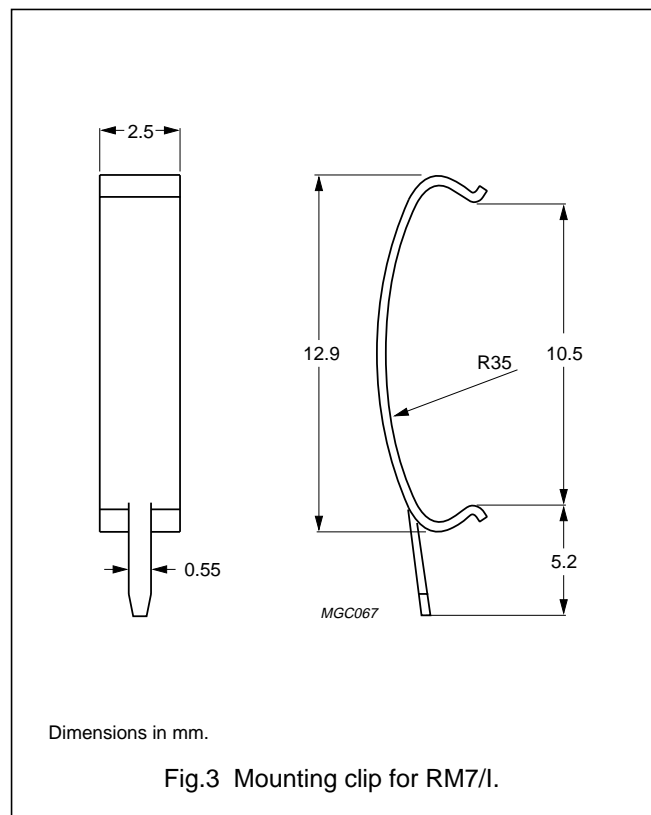

RM cores and accessories

RM7/I



DEFINITIONS

Data sheet status	
Objective specification	This data sheet contains target or goal specifications for product development.
Preliminary specification	This data sheet contains preliminary data; supplementary data may be published later.
Product specification	This data sheet contains final product specifications.
Application information	
Where application information is given, it is advisory and does not form part of the specification.	

LIFE SUPPORT APPLICATIONS

These products are not designed for use in life support appliances, devices, or systems where malfunction of these products can reasonably be expected to result in personal injury. Philips customers using or selling these products for use in such applications do so at their own risk and agree to fully indemnify Philips for any damages resulting from such improper use or sale.

PRODUCT STATUS DEFINITIONS

STATUS	INDICATION	DEFINITION
Prototype		These are products that have been made as development samples for the purposes of technical evaluation only. The data for these types is provisional and is subject to change.
Design-in		These products are recommended for new designs.
Preferred		These products are recommended for use in current designs and are available via our sales channels.
Support		These products are not recommended for new designs and may not be available through all of our sales channels. Customers are advised to check for availability.

Philips Components – a worldwide company

Australia: Philips Components Pty Ltd., NORTH RYDE,
Tel. (02) 9805 4455, Fax. (02) 9805 4466.

Austria: Österreichische Philips Industrie GmbH, WIEN,
Tel. (01) 601 01 12 41, Fax. (01) 60 101 12 11.

Belarus: Philips Office Belarus, MINSK,
Tel. (5172) 200 924/733, Fax. (5172) 200 773.

Benelux: Philips Nederland B.V., EINDHOVEN, NL,
Tel. (+31 40) 2783 749, Fax. (+31 40) 2788 399.

Brazil: Philips Components, SÃO PAULO,
Tel. (011) 821 2333, Fax. (011) 829 1849.

Canada: Philips Electronics Ltd., SCARBOROUGH,
Tel. (0416) 292 5161, Fax. (0416) 754 6248.

China: Philips Company, SHANGHAI,
Tel. (021) 6354 1088, Fax. (021) 6354 1060.

Denmark: Philips Components A/S, COPENHAGEN S,
Tel. (32) 883 333, Fax. (31) 571 949.

Finland: Philips Components, ESPOO,
Tel. (0) 9 615 800, Fax. (0) 9 615 80510.

France: Philips Composants, SURESNES,
Tel. (01) 4099 6161, Fax. (01) 4099 6493.

Germany: Philips Components GmbH, HAMBURG,
Tel. (040) 2489-0, Fax. (040) 2489 1400.

Greece: Philips Hellas S.A., TAVROS,
Tel. (01) 4894 339/(01) 4894 239, Fax. (01) 4814 240.

Hong Kong: Philips Hong Kong, KOWLOON,
Tel. 2784 3000, Fax. 2784 3003.

India: Philips India Ltd., MUMBAI,
Tel. (022) 4930 311, Fax. (022) 4930 966/4950 304.

Indonesia: P.T. Philips Development Corp., JAKARTA,
Tel. (021) 794 0040, Fax. (021) 794 0080.

Ireland: Philips Electronics (Ireland) Ltd., DUBLIN,
Tel. (01) 76 40 203, Fax. (01) 76 40 210.

Israel: Rapac Electronics Ltd., TEL AVIV,
Tel. (03) 6450 444, Fax. (03) 6491 007.

Italy: Philips Components S.r.l., MILANO,
Tel. (02) 6752 2531, Fax. (02) 6752 2557.

Japan: Philips Japan Ltd., TOKYO,
Tel. (0) 3 3740 5135, Fax. (0) 3 3740 5035.

Korea (Republic of): Philips Electronics (Korea) Ltd., SEOUL,
Tel. (02) 709 -1472, Fax. (02) 709 1480.

Malaysia: Philips Malaysia SDN Berhad
Components Division, PULAU PINANG,
Tel. (03) 750 5213, Fax. (03) 757 4880.

Mexico: Philips Components, EL PASO, U.S.A.,
Tel. (915) 772 4020, Fax. (915) 772 4332.

New Zealand: Philips New Zealand Ltd., AUCKLAND,
Tel. (09) 815 4000, Fax. (09) 849 7811.

Norway: Norsk A/S Philips, OSLO,
Tel. (22) 74 8000, Fax. (22) 74 8341.

Pakistan: Philips Electrical Industries of Pakistan Ltd., KARACHI,
Tel. (021) 587 4641-49, Fax. (021) 577 035/587 4546.

Philippines: Philips Semiconductors Philippines Inc.,
METRO MANILA, Tel. (02) 816 6345, Fax. (02) 817 3474.

Poland: Philips Poland Sp. z.o.o., WARSZAWA,
Tel. (022) 612 2594, Fax. (022) 612 2327.

Portugal: Philips Portuguesa S.A.,
Philips Components: LINDA-A-VELHA,
Tel. (01) 416 3160/416 3333, Fax. (01) 416 3174/416 3366.

Russia: Philips Russia, MOSCOW,
Tel. (095) 755 6918, Fax. (095) 755 6919.

Singapore: Philips Singapore Pte Ltd., SINGAPORE,
Tel. 350 2000, Fax. 355 1758.

South Africa: S.A. Philips Pty Ltd., JOHANNESBURG,
Tel. (011) 470 5911, Fax. (011) 470 5494.

Spain: Philips Components, BARCELONA,
Tel. (93) 301 63 12, Fax. (93) 301 42 43.

Sweden: Philips Components AB, STOCKHOLM,
Tel. (+46) 8 632 2000, Fax. (+46) 8 632 2745.

Switzerland: Philips Components AG, ZÜRICH,
Tel. (01) 488 22 11, Fax. (01) 481 77 30.

Taiwan: Philips Taiwan Ltd., TAIPEI,
Tel. (02) 2134 2900, Fax. (02) 2134 2929.

Thailand: Philips Electronics (Thailand) Ltd., BANGKOK,
Tel. (02) 745 4090, Fax. (02) 398 0793.

Turkey: Türk Philips Ticaret A.S., GÜLTEPE/ISTANBUL,
Tel. (0212) 279 2770, Fax. (0212) 282 6707.

United Kingdom: Philips Components Ltd., DORKING,
Tel. (01306) 512 000, Fax. (01306) 512 345.

United States:

- Display and Wire Wound Components, ANN ARBOR, MI,
Tel. (313) 996 9400, Fax. (313) 761 2776.
- Magnetic Products, SAUGERTIES, NY,
Tel. (914) 246 2811, Fax. (914) 246 0487.
- Passive Components, SAN JOSE, CA,
Tel. (408) 570 5600, Fax. (408) 570 5700.

Yugoslavia (Federal Republic of): Philips Components, BELGRADE,
Tel. (0) 11 625 344/373, Fax. (0) 11 635 777.

For all other countries apply to: Philips Components,
Marketing Communications, P.O. Box 218, 5600 MD EINDHOVEN,
The Netherlands, Fax. +31-40-2724 547.

COD16

© Philips Electronics N.V. 1997

All rights are reserved. Reproduction in whole or in part is prohibited without the prior written consent of the copyright owner.
The information presented in this document does not form part of any quotation or contract, is believed to be accurate and reliable and may be changed without notice.
No liability will be accepted by the publisher for any consequence of its use. Publication thereof does not convey nor imply any license under patent- or other industrial or intellectual property rights.

Printed in The Netherlands

Let's make things better.

**Philips
Components**



PHILIPS