

Insulated terminal binding post with a 4mm socket. Panel insulating bushes have a location keyway, maximum panel thickness 12,7mm. Threaded termination supplied with solder tag washer.

### Dimensions

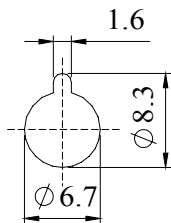
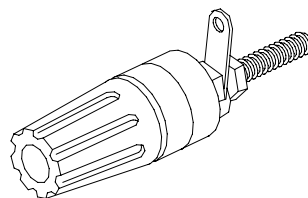
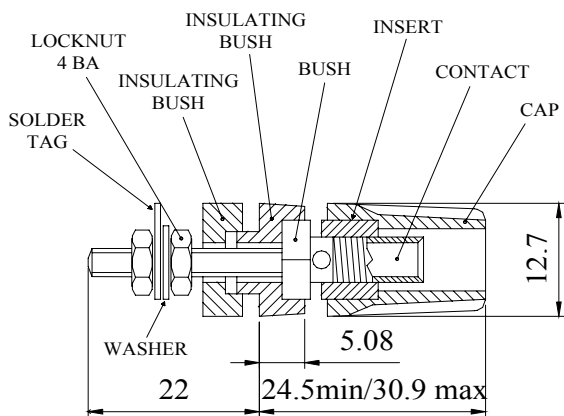

PANEL CUT-OUT

### MATERIAL

- CAP : Acetal
- CONTACT : Brass, bright nickel plate
- INSERT : Brass, bright nickel plate
- BUSH : Brass, bright nickel plate
- INSULATING BUSHES : Acetal
- LOCKNUT : Brass, bright nickel plate
- WASHER : Brass, bright nickel plate

- SOLDER TAG : Brass, silver plate

- Current Rating : 16 Amps
- Rated Voltage : 50V

COLOUR	ORDER CODE
BLACK	552-0100
BLUE	552-0200
BROWN	552-0300
GREEN	552-0400
RED	552-0500
WHITE	552-0600
YELLOW	552-0700

Tel No. +44(0)1724 273200 Website www.dem-uk.com

**PROPRIETARY AND CONFIDENTIAL**  
 THE INFORMATION CONTAINED IN THIS DRAWING IS THE SOLE PROPERTY OF  
 ALPHA 3 MANUFACTURING.  
 ANY REPRODUCTION IN PART OR AS A WHOLE WITHOUT THE WRITTEN PERMISSION OF  
 ALPHA 3 MANUFACTURING IS PROHIBITED.

UNLESS OTHERWISE SPECIFIED:  
 DIMENSIONS ARE IN MILLIMETRES  
 LINEAR TOLERANCE:  
**NO DECIMAL PLACES ±0.5mm**  
**1 DECIMAL PLACE ±0.25mm**  
**2 DECIMAL PLACES ±0.125mm**  
**ANGULAR TOLERANCE: ±1°**

FINISH INSULATED TERMINAL DEBURR AND BREAK SHARP EDGES  
 DRAWN BY SPB  
 APPROVED BY WJC  
 THIRD ANGLE PROJECTION  
 IF IN DOUBT ASK DO NOT SCALE DRAWING  
 MATERIAL SEE NOTE

SHEET 1 OF 1  
 SCALE 1:1  
 A4

TITLE GENERAL SPECIFICATION FOR 552 SERIES  
 DRAWING NO. 552 SERIES  
 ISSUE 05  
 Release



DEM Manufacturing, Deltron Emcon House  
 Hargreaves Way, Sowcliffe Ind. Park,  
 Scunthorpe, North Lincolnshire, DN15 8RF, UK