

PROPER USE GUIDELINES

Cumulative Trauma Disorders can result from the prolonged use of manually powered hand tools. Hand tools are intended for occasional use and low volume applications. A wide selection of powered application equipment for extended-use, production operations is available.

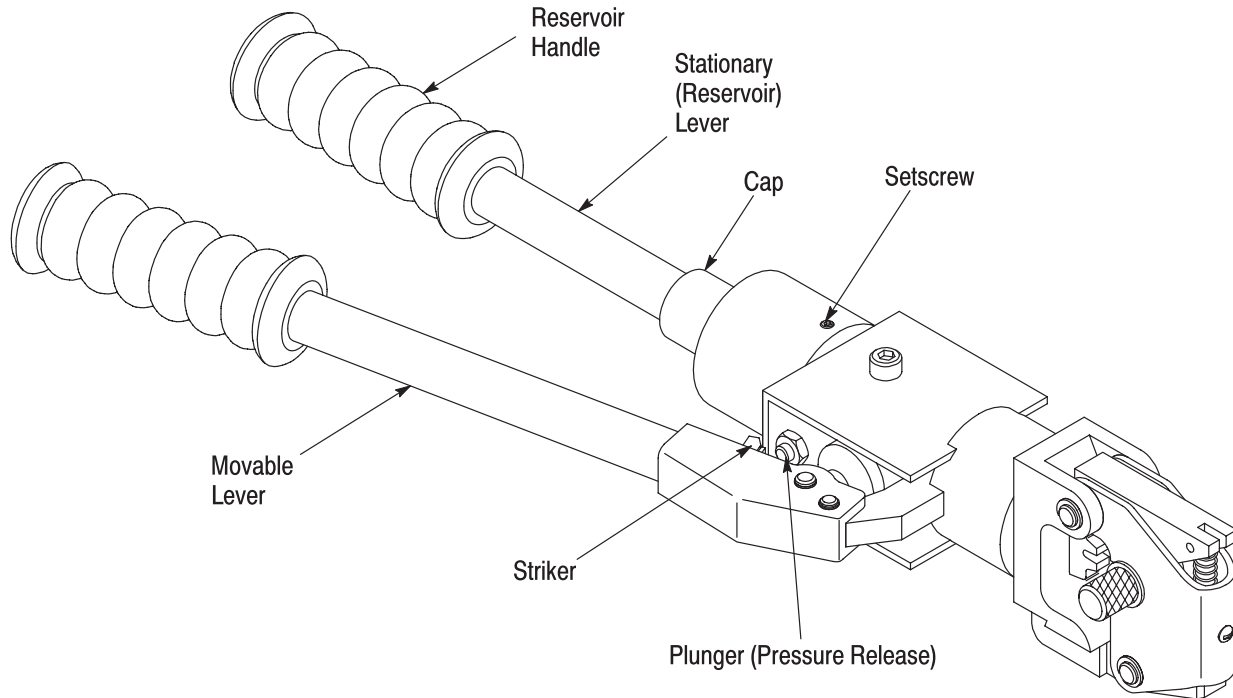

WIRE SIZE (AWG)	WIRE STRIP LENGTH (mm [In.])			
	TERMINALS		BUTT SPLICES AND PARALLEL SPLICES	
	MIN.	MAX.	MIN.	MAX.
8	8.33 [.328]	9.14 [.360]	10.31 [.406]	11.13 [.438]
6	9.91 [.390]	10.72 [.422]	11.91 [.469]	12.70 [.500]
4	11.51 [.453]	12.29 [.484]	13.49 [.531]	14.30 [.563]
2	13.11 [.516]	13.89 [.547]	15.09 [.594]	15.88 [.625]

Figure 1

1. INTRODUCTION

Hydraulic Hand Tool 59975-1 is designed for crimping SOLISTRAND* terminals and splices on AWG 8 through AWG 2 wire. Read these instructions thoroughly before crimping any terminals or splices.



All dimensions on this sheet are in metric units [with U.S. customary units in brackets]. Figures and illustrations are for reference only and are not drawn to scale.

Reasons for reissue of this sheet are provided in Section 7, REVISION SUMMARY.

2. DESCRIPTION (Figure 1)

The hand tool has a stationary lever and a movable lever. These levers are compressed to pump hydraulic fluid behind the ram, moving it forward and thereby closing the dies. After the crimping is complete, the movable lever is turned to depress the plunger. The moving die retracts to its original position, completing the crimping cycle.

3. DIE SELECTION (Figure 2)

1. Press head latch and open crimping head as shown.
2. Pull back the die latch and turn thumb knob until desired die size appears. (Embossed wire size appears on side of each die position.)

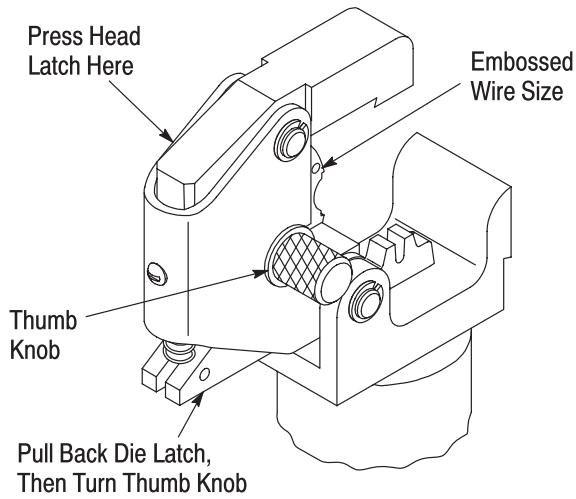

Figure 2

3. Rotate thumb knob left or right until die latch locks die wheel in desired position.
4. Close head.



In order to close head, die latch must “snap” into locked position.

4. CRIMPING PROCEDURE

1. Strip wires to dimensions listed in Figure 1.
2. Insert terminal or splice in upper die as shown in Figure 3.
3. Pump movable lever until moving (lower) die grips terminal or splice.



Do not deform wire barrel of terminal or splice.

4. Insert stripped wire into wire barrel of terminal or splice.
5. Continue pumping moveable lever. A slight click may be heard, indicating the pump has shifted into the high-pressure stage. Continue pumping moveable lever. When dies have bottomed, an audible “pop” will be heard. This indicates that the crimp is complete.
6. Retract movable die by turning movable handle (to actuate striker), compress levers to depress plunger. Movable die will now retract. See Figure 1.
7. Remove crimped terminal or splice.



If terminal or splice sticks in die after crimping, apply a rocking action to remove it from die.

8. Inspect crimp for the following criteria:
 - a. Centering of crimp (crimp may be off center but not off end of wire barrel).
 - b. Wire size being used matches wire range stamped on die position and terminal.
 - c. End of wire is flush with or extends slightly beyond end of wire barrel.
 - d. There are no nicked or missing strands.
9. Inspect crimped terminal or splice according to inspection procedure on instruction sheet packaged with the dies.

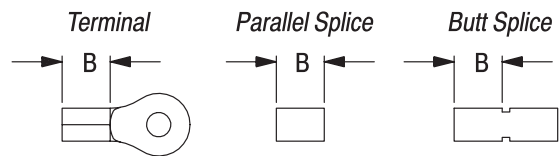

“B” Equals Wire Barrel

Center Terminal or Splice Wire Barrel in Upper Die

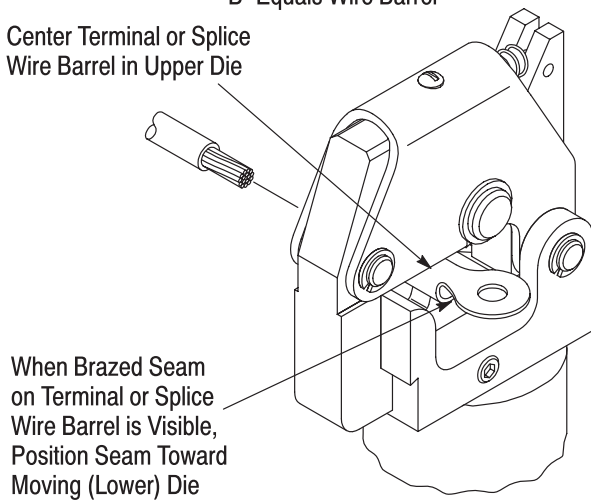

Figure 3

5. MAINTENANCE/INSPECTION

Tyco Electronics recommends that a maintenance and inspection program be performed periodically to ensure dependable and uniform terminations. Though recommendations call for at least one inspection a month, frequency of inspection depends on:

1. The care, amount of use, and handling of the hand tool.
2. The presence of abnormal amounts of dust and dirt.
3. The degree of operator skill.

4. Your own established standards.

The hand tool is inspected before being shipped; however, Tyco Electronics recommends that the tool be inspected immediately upon arrival at your facility to ensure that the tool has not been damaged during shipment.

5.1. Daily Maintenance

1. Hand tool should be immersed (handles partially closed) in a reliable commercial degreasing compound to remove accumulated dirt, grease, and foreign matter. When degreasing compound is not available, tool may be wiped clean with a soft, lint-free cloth. Do NOT use hard or abrasive objects that could damage the tool.
2. Make certain that the retaining pins are in place and that they are secured with retaining rings.



Do not remove the retaining pins as permanent damage to the tool could result.

3. All pins, pivot points, and bearing surfaces should be protected with a THIN coat of any good SAE 20 motor oil. Do NOT oil excessively.
4. When the tool is not in use, keep handles closed to prevent objects from becoming lodged in the crimping jaws. Store the tool in a clean, dry area.

5.2. Hydraulic Fluid Level Inspection (Figure 4)

1. Turn tool upside down and clamp it in a vise so that tool handles are in an upright position.
2. Release all pressure in tool according to instructions in Section 4, CRIMPING PROCEDURE, Step 6.
3. Un-turn handle and allow movable lever to close until it stops. Be sure not to depress plunger when closing handle.



Keep handle in CLOSED position for remaining steps in this procedure.

4. Loosen setscrew in cap of stationary (reservoir) lever. See Figure 1.
5. With view from handle grip end, turn handle COUNTERCLOCKWISE and remove entire reservoir lever to expose bladder.
6. Remove magnetic filler plug. If bladder is full, no further check is necessary and tool can be re-assembled. If fluid level is low, proceed to Step 7.

● Trademark of General Motors Corp.

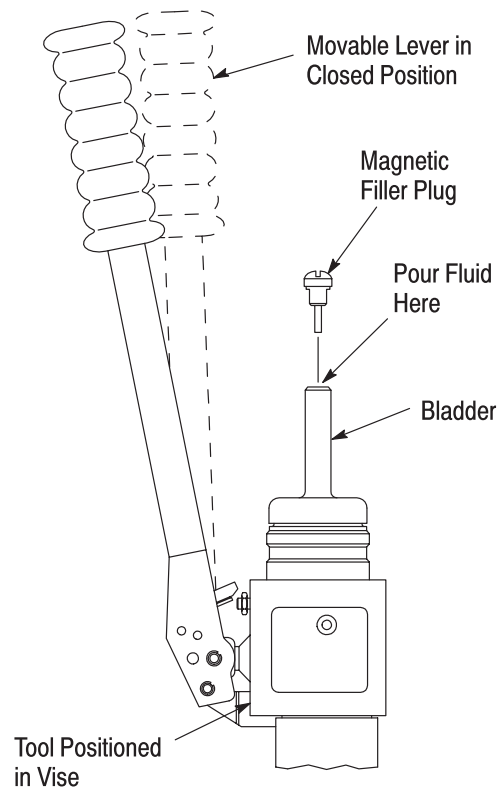

Figure 4

7. Fill bladder with fluid. Recommended fluid is Dexron● II, which is a transmission fluid available in automotive parts and department stores. Use care to prevent air bubbles from forming while pouring the fluid.
8. Refill bladder to point of overflow, and replace filler plug.
9. Re-assemble reservoir handle and tighten cap setscrew. Tool is now ready for use.

5.3. Periodic Inspection

We recommend at least one inspection a month, the inspection frequency should be based on the amount of use, ambient working conditions, operator training and skill, and your company's established standards.

A. Lubrication

Keep all pins, pivot points, and bearing surfaces lubricated with SAE 20 motor oil as follows:

- Tool used in daily production – lubricate daily
- Tool used daily (occasionally) – lubricate weekly
- Tool used weekly – lubricate monthly

Wipe excess oil from tool, particularly from crimping area. Oil transferred from the crimping area onto certain terminations may affect the electrical characteristics of an application.

B. Visual Inspection

1. Make certain all retaining pins are in place and secured with retaining rings. If replacements are necessary, refer to parts listed in Figure 6.
2. Inspect head assembly for worn, cracked, or broken crimping dies. If damage is evident, return the tool to Tyco Electronics for evaluation and repair. See Section 6, REPLACEMENT AND REPAIR.

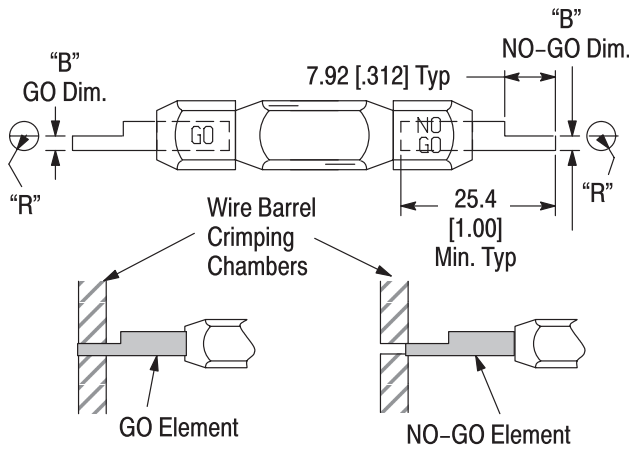

DIE SIZE	GAGE ELEMENT DIMENSIONS "B" (mm [in.])		RADIUS "R"
	GO	NO-GO	
8	2.184 - 2.192 [.0860 - .0863]	2.537 - 2.540 [.0999 - .1000]	3.58 [.141]
6	3.124 - 3.132 [.1230 - .1233]	3.477 - 3.480 [.1369 - .1370]	3.96 [.156]
4	4.039 - 4.046 [.1590 - .1593]	4.392 - 4.394 [.1729 - .1730]	5.56 [.219]
2	4.826 - 4.834 [.1900 - .1903]	5.179 - 5.182 [.2039 - .2040]	6.35 [.250]

Figure 5

C. Gaging the Crimping Chamber

This inspection requires the use of a plug gage conforming to the dimensions in Figure 5. Tyco Electronics does not manufacture or market these gages.

Proceed as follows:

1. Clean oil or dirt from die closure surfaces and plug gage elements.
2. Rotate knob on tool to select die closure to be inspected. (Refer to Section 3, DIE SELECTION.)
3. Actuate tool until dies are closed and an audible "pop" is heard.
4. Align the GO element with the wire barrel crimping chamber. Push element straight into the crimping chamber without using force. The GO

element must pass completely through the crimping chamber as shown in Figure 5.

5. Now align the NO-GO element and try to insert it straight into the same crimping chamber. The NO-GO element may start entry but must not pass completely through as shown in Figure 5.

6. Repeat Steps 2 through 5 for each die size listed in the chart.

If the crimping chamber conforms to the gage inspection, the tool is considered dimensionally correct and should be lubricated with a THIN coat of any good SAE 20 motor oil. If not, the tool must be repaired before returning it to service. See Section 6, REPLACEMENT AND REPAIR.

D. Crimping Pressure Inspection

Check the crimping pressure to ensure that dies are fully bottomed before pressure is reduced by the internal bypass valve.

1. Select the largest wire and terminal size that will be crimped in the tool.
2. Select dies according to Section 3, DIE SELECTION.
3. Place terminal or splice in dies according to instructions in Section 4, CRIMPING PROCEDURE.
4. Perform crimping procedure as described in Steps 3 thru 5 of Section 4, CRIMPING PROCEDURE. Do not release hydraulic pressure at this time.
5. When ram is fully extended and Steps 1 thru 4 are completed, a scribe line should appear on the ram at the base of the cylinder head. This indicates that the pressure requirement has been met. If the scribe is NOT visible, that tool is not performing properly and should be repaired as described in Section 6, REPLACEMENT AND REPAIR.

If the tool conforms to these inspection procedures, lubricate it with a THIN coat of any good SAE 20 motor oil and return it to service.

6. REPLACEMENT AND REPAIR

The parts listed in Figure 6 are customer-replaceable. A complete inventory can be stocked and controlled to prevent lost time when replacement of parts is necessary. Order replacement parts through your Tyco Electronics Representative, or call 1-800-526-5142, or send a facsimile of your purchase order to 1-717-986-7605, or write to:

CUSTOMER SERVICE (038-035)
 TYCO ELECTRONICS
 P.O. BOX 3608
 HARRISBURG, PA 17105-3608

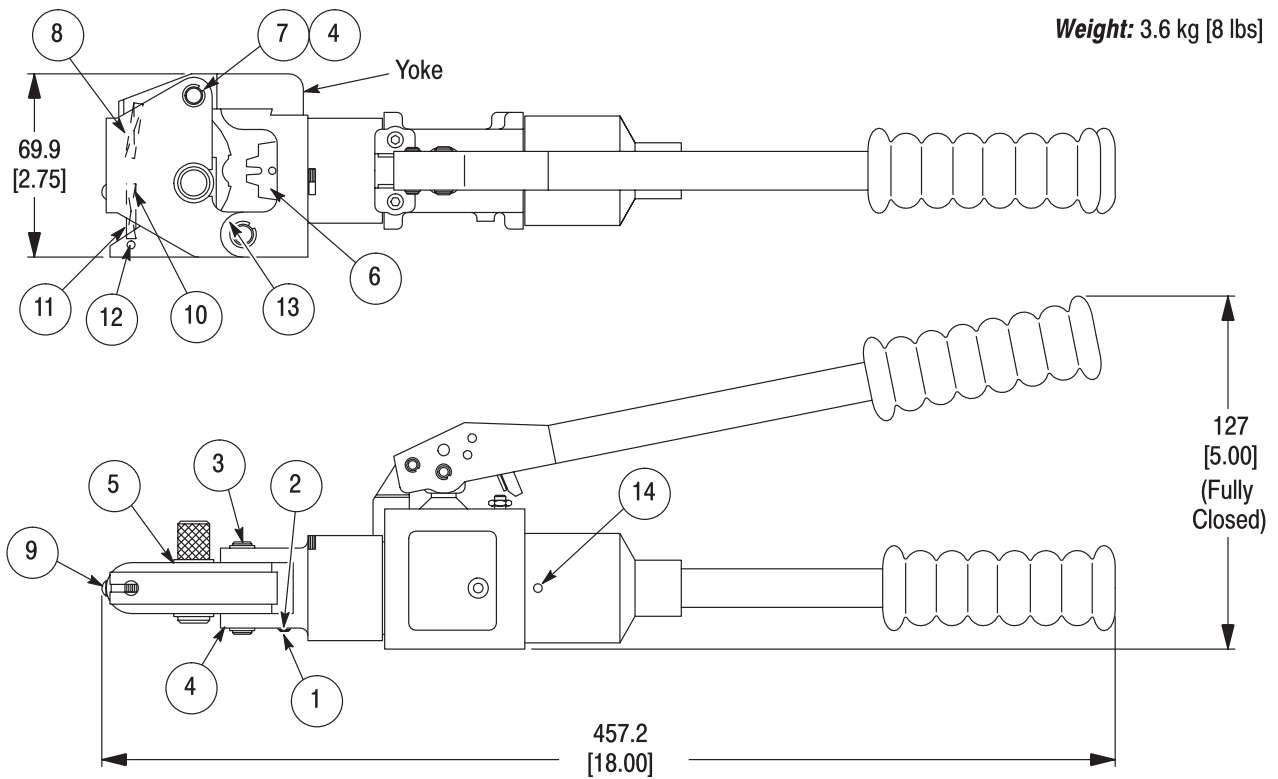

REPLACEMENT PARTS

ITEM	PART NUMBER	DESCRIPTION	QTY PER ASSY
1	4-305927-0	SCREW	1
2	21025-4	WASHER, Lock, Internal Tooth No. 8	1
3	301710	PIN, Retaining	1
4	21045-8	RING, Retaining	4
5	1-21045-3	RING, Retaining	2
6	47322	INDENTER	1
7	301707	PIN, Retaining	1
8	301712	SPRING	1
9	2-305927-5	SCREW	1
10	304028	STOP, Spring	1
11	304029	SPRING	1
12	3-21028-5	PIN, Roll, .094 Dia x .438 L	1
13	2-21028-4	PIN, Roll, .078 Dia x .812 L	1
14	4-21006-9	SCREW, Set	1

Figure 6

For customer repair service, contact a Tyco Electronics Representative at 1-800-526-5136.

changes were made:

7. REVISION SUMMARY

Since the previous release of this sheet, the following

- Updated document to corporate requirements
- Added new text to Paragraph 5.3.D