

# 19 mm (0.75") DIAMETER STAINLESS STEEL COMPRESSION LOAD CELL

## STANDARD AND METRIC MODELS

### Compression

0-25 lb to 0-1000 lb  
0-100 to 0-5000 N

1 Newton = 0.2248 lb  
1 daNewton = 10 Newtons  
1 lb = 454 g  
1 t = 1000 kg = 2204 lb

### LC302/LCM302 Series



- ✓ Small 19 mm (0.75") Dia.
- ✓ Low 13 mm (0.5") Profile
- ✓ Robotic and Test Bench Applications
- ✓ Built-In Load Button for Easy Installation
- ✓ 5-Point Traceable Calibration Provided

The LC302/LCM302 Series load cells are only 19 mm (¾") in diameter and fit in the smallest places. Their high ±0.5% accuracy and small package solve many industrial force measurement applications. The all stainless steel construction and high-quality strain gage ensure long-term reliability.

### SPECIFICATIONS

**Excitation:** 5 Vdc, 15 Vdc max

**Output:** 1 mV/V (nominal)

**Accuracy:** ±0.5% FSO linearity, hysteresis, repeatability combined

**5-Point Calibration:** 0%, 50%, 100%, 50%, 0%

**Zero Balance:** ±2% FSO

**Operating Temp Range:** -54 to 125°C (-65 to 250°F)

**Compensated Temp Range:** 16 to 71°C (60 to 160°F)

**Thermal Effects:**

**Zero:** 0.009% FSO/°F

**Span:** 0.036% FSO/°F

**Safe Overload:** 150% of capacity

**Protection Class:** IP54

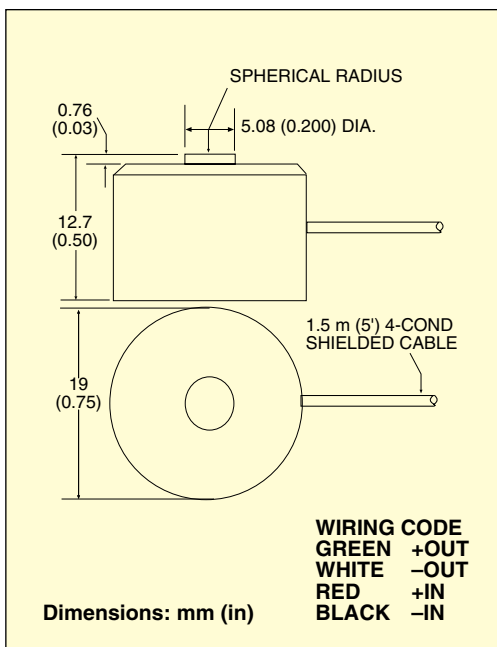

**Deflection:** 0.03 to 0.08 mm (0.001 to 0.003")

**Ultimate Overload:** 300% of capacity  
**Bridge Resistance:** 350 Ω minimum

**Construction:** Stainless steel  
**Electrical Connection:** 1.5 m (5') 4-conductor insulated cable with temperature compensation board

### STANDARD MODELS

**To Order Visit [newportUS.com/lc302](http://newportUS.com/lc302) for Pricing and Details**

CAPACITY		MODEL NO.	COMPATIBLE METERS
lb	N		
25	111	LC302-25	DPiS, DP41-S, DP25B-S
50	222	LC302-50	DPiS, DP41-S, DP25B-S
100	445	LC302-100	DPiS, DP41-S, DP25B-S
250	1112	LC302-250	DPiS, DP41-S, DP25B-S
500	2224	LC302-500	DPiS, DP41-S, DP25B-S
1000	4448	LC302-1K	DPiS, DP41-S, DP25B-S

### METRIC MODEL

CAPACITY		MODEL NO.	COMPATIBLE METERS
N	lb		
100	22.5	LCM302-100N	iSeries, DP41-S, DP25B-S
200	45	LCM302-200N	iSeries, DP41-S, DP25B-S
500	112	LCM302-500N	iSeries, DP41-S, DP25B-S
1000	225	LCM302-1KN	iSeries, DP41-S, DP25B-S
2000	450	LCM302-2KN	iSeries, DP41-S, DP25B-S
5000	1124	LCM302-5KN	iSeries, DP41-S, DP25B-S

Comes complete with 5-point NIST-traceable calibration and 59 kΩ shunt data.

**Ordering Examples:** LC302-25, 25 lb capacity load cell.

LC302-100, 100 lb capacity load cell.

LCM302-100N, 100 Newton capacity load cell.

LCM302-2KN, 2000 N capacity load cell.