

Shrink Boots- Straight and Right Angle, for Series 80 Connectors



Protect Your Cable Harness with heat-shrinkable boots. These easy-to-use boots provide excellent electrical, mechanical and environmental protection. Heating the boot causes the boot to shrink onto the connector and cable. An optional adhesive lining bonds the boot to the connector and cable and fills small gaps for a complete seal. Choose straight cable exit or right angle exit. These lipped boots attach directly to Series 80 Mighty Mouse connectors with integral band platform. After shrinking, the boot lip locks into groove. Choose Type 1 high performance elastomer for extreme temperatures and excellent resistance to fuels and oils, Type 2 non-halogenated flame-retardant polyolefin for use where limited fire hazard is required.



Material Selection Guide

Attribute	Type 1 High Performance Semi-Rigid Elastomer	Type 2 Zero Halogen Semi-Rigid Polyolefin
Continuous Operating Temp.	-75° to +150°C	-30° to +125°C
Resistance to Fuels, Oils	Excellent	Very Good
Low Toxicity, Zero Halogen	No	Yes

Type 1 High performance Elastomer

Semi-rigid high performance boots combine excellent resistance to fuels, oils and solvents with superior performance at extreme temperatures. Rated for 3000 hours continuous operation at +150° C, these boots fit most standard boot adapters for circular connectors. Material meets the requirements of VG95343 Type 6, BSG 198-5-DE, EN62329-102 and SAE AS5258 Type H. These boots are recommended for demanding applications such as military vehicles and petrochemical exploration. Black color.

Type 2 Zero halogen

Halogen-free polyolefin boots meet low smoke and toxicity requirements of shipboard, transit and aircraft systems. These Low Smoke/Zero Halogen (LSZH) boots fit most standard shrink boot adapters, including M85049 types along with Glenair Series 31 and Series 44 adapters. Oxygen index greater than 30%, smoke index less than 20, and toxicity index under 3 per 100 grams. Material meets requirements of NAVSEA 5617649, VG95343 Part 29, BSG 198-5-DF, EN62329-101 and SAE AS5258 Type G. Good resistance to oils, fuels and solvents. These boots provide strain relief and environmental protection to connector/cable transitions. Temperature rating -30° to +125° C. Black color.

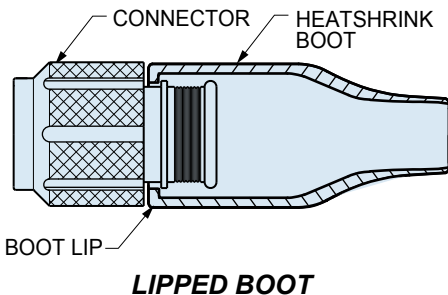

Lipped Straight Shrink Boots- Type I High Performance Elastomer

- -75° C to +150° C
- Excellent resistance to fuels, oils, solvents and heat.



Boot Size	Shell Size		Part Number
	Series 800, 801, 802, 803, 804	Series 805	Pre-Coated with W1 Hi-Temp Hot-Melt Adhesive
1	5	N/A	809S060-1
2	6, 7	8, 9	809S060-2
3	8, 9	10, 11	809S060-3
4	10, 12, 13	12, 15	809S060-4
5	14, 15, 16, 17	18, 19	809S060-5
6	21	23	809S060-6

Lipped Straight Shrink Boots- Type 2 Zero Halogen, Semi-Rigid

- Low Smoke, Zero Halogen
- Meets U.S. and E.U. toxicity requirements.



Boot Size	Shell Size		Part Number
	Series 800, 801, 802, 803, 804	Series 805	Pre-Coated with W1 Hi-Temp Hot-Melt Adhesive
1	5	N/A	809S060-1H
2	6, 7	8, 9	809S060-2H
3	8, 9	10, 11	809S060-3H
4	10, 12, 13	12, 15	809S060-4H
5	14, 15, 16, 17	18, 19	809S060-5H
6	21	23	809S060-6H

Lipped Right Angle Boots- Type I High Performance Elastomer

- -75° C to +150° C
- Excellent resistance to fuels, oils, solvents and heat.



Boot Size	Shell Size		Part Number
	Series 800, 801, 802, 803, 804	Series 805	Pre-Coated with W1 Hi-Temp Hot-Melt Adhesive
1*	5	N/A	809A060-1
2	6, 7	8, 9	809A060-2
3	8, 9	10, 11	809A060-3
4	10, 12, 13	12, 15	809A060-4
5	14, 15, 16, 17	18, 19	809A060-5
6	21	23	809A060-6

* Size 1 right angle boot does not have lip. See drawing on following page.

Lipped Right Angle Shrink Boots- Type 2 Zero Halogen, Semi-Rigid

- Low Smoke, Zero Halogen
- Meets U.S. and E.U. toxicity requirements.



Boot Size	Shell Size		Part Number
	Series 800, 801, 802, 803, 804	Series 805	Pre-Coated with W1 Hi-Temp Hot-Melt Adhesive
1*	5	N/A	809A060-1H
2	6, 7	8, 9	809A060-2H
3	8, 9	10, 11	809A060-3H
4	10, 12, 13	12, 15	809A060-4H
5	14, 15, 16, 17	18, 19	809A060-5H
6	21	23	809A060-6H

* Size 1 right angle boot does not have lip. See drawing on following page.

Dimensions in inches (millimeters) and are subject to change without notice.

Lipped Straight Shrink Boots- Dimensions

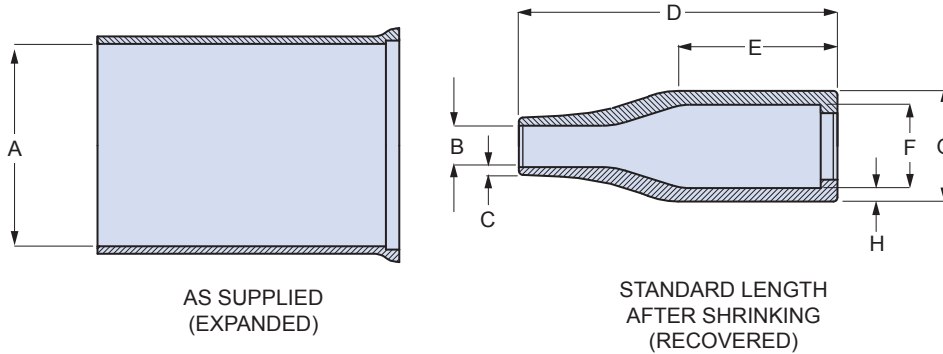

Boot Size	A Min.		B Max.		C ± 20%		D ± 10%		E Ref.		F Max.		G Ref.		H ± 30%	
	In.	mm.	In.	mm.	In.	mm.	In.	mm.	In.	mm.	In.	mm.	In.	mm.	In.	mm.
1	.390	9.9	.079	2.0	.030	0.76	1.37	34.8	.75	19.0	.28	7.1	.36	9.1	.050	1.3
2	.669	17.0	.140	3.56	.032	0.81	1.500	38.1	.750	19.1	.300	7.6	.410	10.4	.055	1.4
3	.945	24.0	.197	5.0	.040	1.00	1.496	38.0	.748	19.0	.413	10.5	.520	13.2	.063	1.6
4	1.181	30.0	.236	6.0	.046	1.17	2.165	55.0	1.181	30.0	.551	14.0	.693	17.6	.071	1.8
5	1.260	32.0	.276	7.0	.052	1.32	2.638	67.0	1.299	33.0	.709	18.0	.850	21.6	.071	1.8
6	1.693	43.0	.394	10.0	.052	1.32	3.15	80.0	2.575	40.0	.90	23.0	0.945	24.0	.080	2.0

Lipped Right Angle Shrink Boots- Dimensions

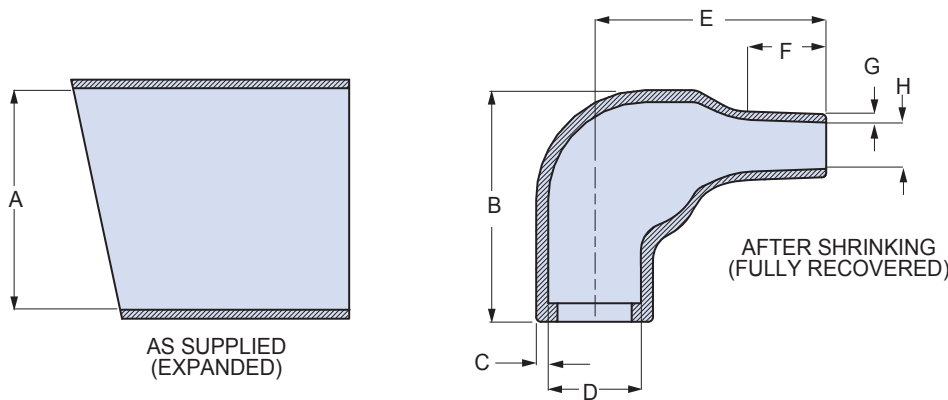

Boot Size	A Min.		B Ref.		C ± 30%		D Max.		E ± 20%		F Ref.		G ± 20%		H Max.	
	In.	mm.	In.	mm.	In.	mm.	In.	mm.	In.	mm.	In.	mm.	In.	mm.	In.	mm.
1	.390	9.9	.787	20.0	.050	0.76	.27	6.9	.20	5.1	.28	7.1	.032	0.8	.095	2.4
2	.669	17.0	.787	20.0	.051	1.3	.315	8.0	.787	20.0	.276	7.0	.032	0.8	.138	3.5
3	.945	24.0	.984	25.0	.063	1.6	.394	10.0	.984	25.0	.394	10.0	.035	0.40	1.0	5.0
4	1.181	30.0	1.063	27.0	.071	1.8	.532	13.5	1.260	32.0	.472	12.0	.046	1.2	.217	5.5
5	1.260	32.0	1.260	32.0	.080	1.32	.709	18.0	1.535	39.0	.591	15.0	.052	1.3	.276	7.0
6	1.417	36.0	1.50	38.1	.087	2.2	.90	22.9	1.890	48.0	.630	16.0	.052	1.3	.330	8.4

Dimensions in inches (millimeters) and are subject to change without notice.

CAGE Code 06324

Printed in U.S.A.