

REVISIONS	
ISS	DESCRIPTION \ DATE

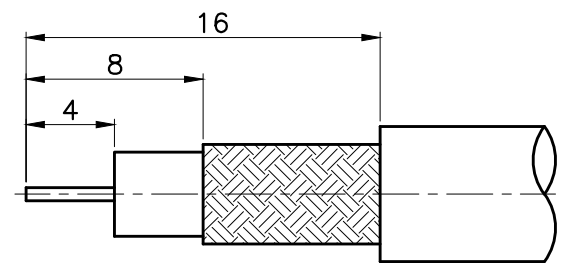

RoHS COMPLIANT

RECOMMENDED  
CABLE STRIPPING DIM'S

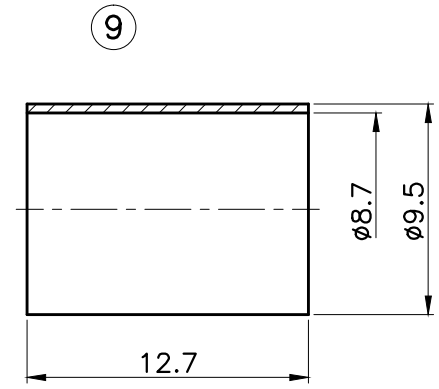
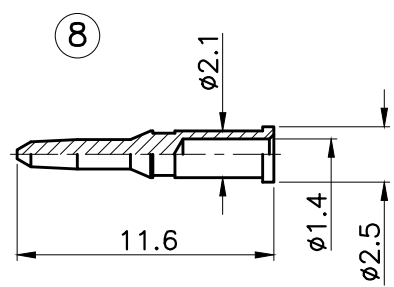
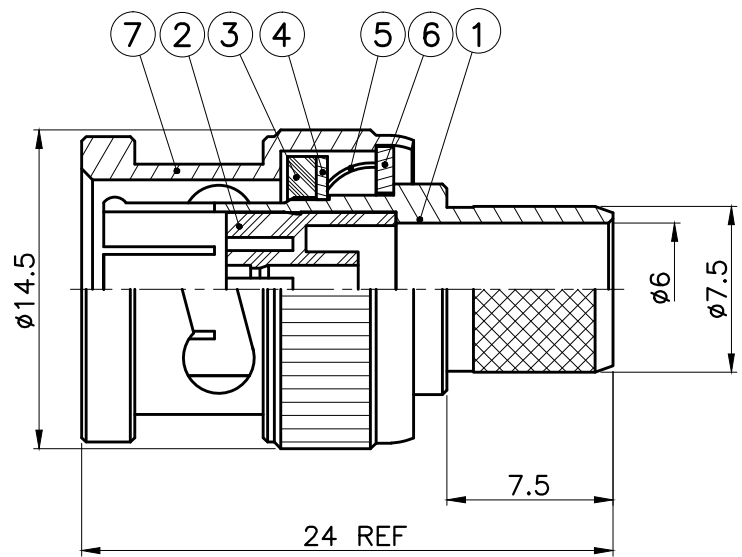

1. CRIMPED FERRULE  
HEX CRIMP SIZE .324"
2. CRIMPED CONTACT PIN  
HEX CRIMP SIZE .068"



TITLE: BNC MALE CRIMP(75 ohm)  
(FOR CT125)  
PART NO: BNC1-125  
DRAWING NO: 50312-050(B002B125-96)

APRD:  
CHKD:  
DR:  
DATE: 12/12/07"  
SHEET: .

UNLESS OTHERWISE  
SPECIFIED TOLERANCES  
0.5-6 = ±0.2  
>6-30 = ±0.4  
>30-120 = ±0.6  
>120-315 = ±1  
>315-1000 = ±1.6  
ANGLES = ±5°  
UNIT: mm  
SCALE: 3/1

9	FERRULE	BRASS	NICKEL
8	CONTACT PIN	BRASS	GOLD
7	SHELL	BRASS	NICKEL
6	WASHER	STEEL	NICKEL
5	SPRING	SK-5	NICKEL
4	C WASHER	STEEL	NICKEL
3	GASKET	PVC	RED
2	INSULATOR	DELTRIN	WHITE
1	BODY	BRASS	NICKEL
NO.	DESCRIPTION	MATERIAL	FINISH