

REVISION R

DO NOT SCALE FROM THIS PRINT

ZF1-XX-XX-XX-WT-XX

No OF POSITIONS
-04 THRU -30

LEAD STYLE
-01: CONTACT BOTTOM
-02: CONTACT TOP
* -03: TOP ENTRY (SEE SHEET 3)

OPTIONS
-TR: TAPE AND REEL (SEE SHEET 4, FIG 3)

WELD TAB

PLATING SPECIFICATION
-T: PURE TIN, MATTE FINISH
-TM: PURE TIN, MATTE FINISH

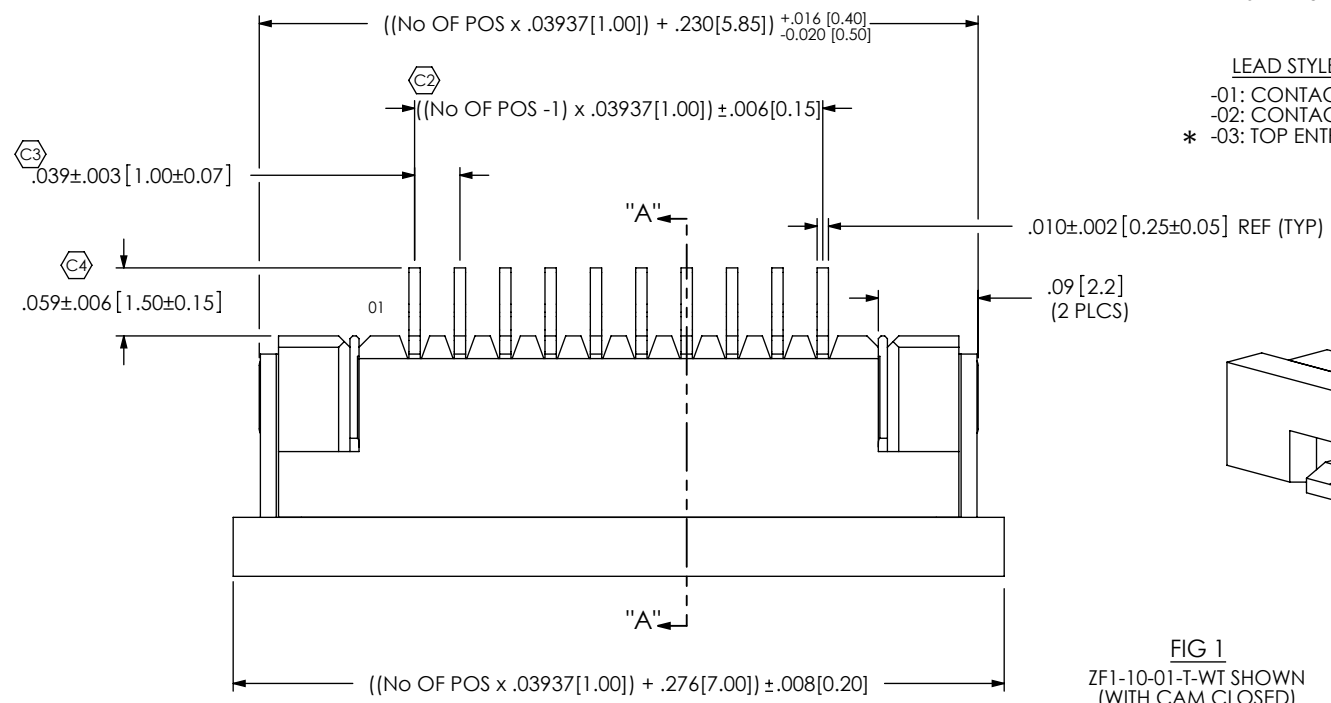

* -03 LEAD STYLE AVAILABLE TO EXISTING CUSTOMERS ONLY AS OF REVISION P

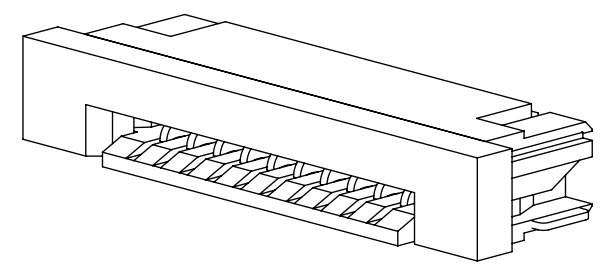
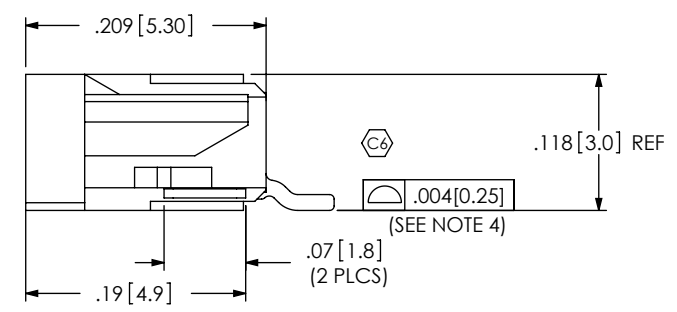
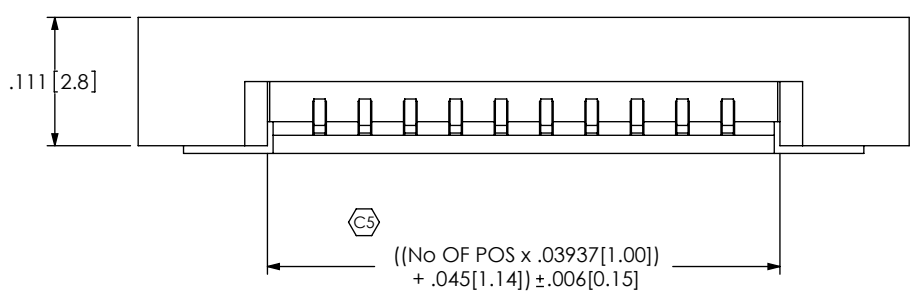

FIG 1
ZF1-10-01-T-WT SHOWN (WITH CAM CLOSED)



- NOTES:
1. CC REPRESENTS A CRITICAL DIMENSION.
 2. BURR ALLOWANCE: .0010[.025] MAXIMUM.
 3. CONTACT; MINIMUM PUSHOUT FORCE: 6 OZ.
 4. COPLANARITY INCLUDES TAILS AND WELD TABS.
 5. WELD TAB RETENTION: 12 OZ.
 6. BREAKOFF BURR NOT TO EXCEED .007[0.18] & MUST REMAIN ATTACHED.

UNLESS OTHERWISE SPECIFIED, DIMENSIONS ARE IN INCHES. TOLERANCES ARE:
 DECIMALS ANGLES
 .XX: $\pm .01 [0.4]$ 2°
 .XXX: $\pm .010 [0.25]$
 .XXXX: $\pm .XXXX [XXX]$

PROPRIETARY NOTE
 THIS DOCUMENT CONTAINS INFORMATION CONFIDENTIAL AND PROPRIETARY TO SAMTEC, INC. AND SHALL NOT BE REPRODUCED OR TRANSFERRED TO OTHER DOCUMENTS OR DISCLOSED TO OTHERS OR USED FOR ANY PURPOSE OTHER THAN THAT WHICH IT WAS OBTAINED WITHOUT THE EXPRESSED WRITTEN CONSENT OF SAMTEC, INC.

520 PARK EAST BLVD, NEW ALBANY, IN 47150
 PHONE: 812-944-6733 FAX: 812-948-5047
 e-Mail: info@SAMTEC.com code: 55322

MATERIAL: DO NOT SCALE DRAWING SHEET SCALE: 6:1
 HOUSING: LCP E130i 94-V2, COLOR: NATURAL
 CAM SLIDER: PPS D5 94-V2, COLOR: BLACK
 CONTACT & WELD TAB: PHOS BRONZE
 MAX FLASH ALLOWED: .002
 MAX GATE VESTIGE: .002
 F:\DWG\MISC\MKTG\ZF1-XX-XX-XX-WT-XX-MKT.SLDDRW

DESCRIPTION:
 ZERO INSERTION FORCE 1mm ASSEMBLY

DWG. NO.
ZF1-XX-XX-XX-WT-XX

BY: KEVIN B 9/20/2002 SHEET 1 OF 4

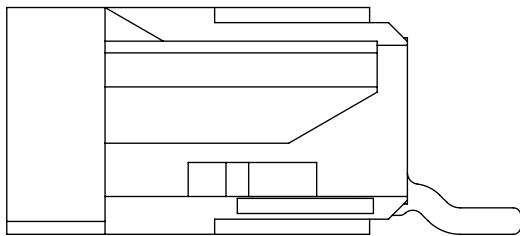

-01 LEAD STYLE [CONTACT BOTTOM]
(WITH CAM OPEN)

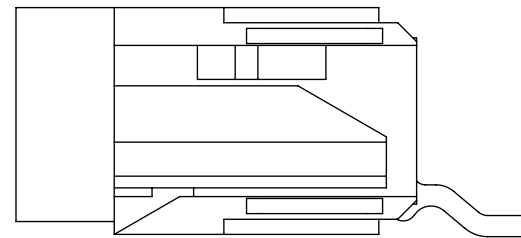

-02 LEAD STYLE [CONTACT TOP]
(WITH CAM OPEN)

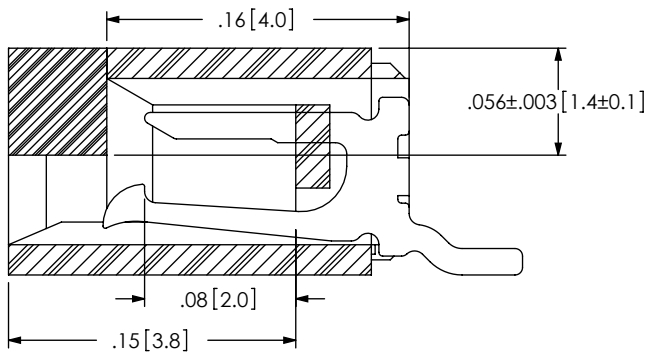

SECTION "A"-"A"

-01 LEAD STYLE
(WITH CAM CLOSED)

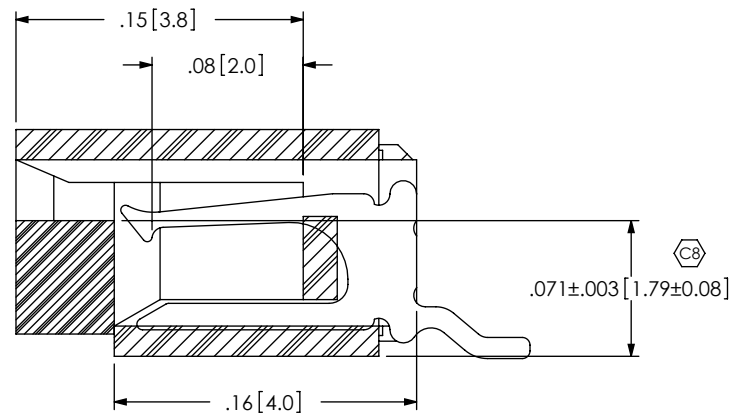

SECTION "A"-"A"

-02 LEAD STYLE
(WITH CAM CLOSED)

PACKAGING VIEWS
(-TR OPTION SHOWN ON SHEET 4)

[PARTS TO HAVE POSITION #1 LOADED IN
SAME DIRECTION AS ARROW ON TUBE]

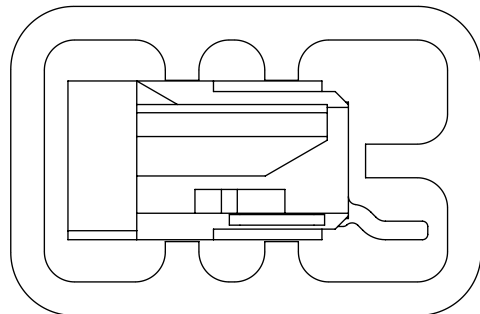

-01 & -02 LEAD STYLE:
TUBE: PT-1-24-02-117
PLUG: TP-24

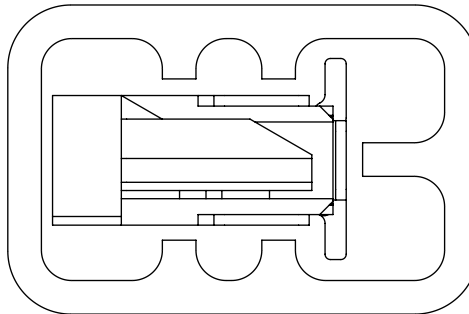

-03 LEAD STYLE:
TUBE: PT-1-24-02-117
PLUG: TP-24

F:\DWG\MISC\MKTG\ZF1-XX-XX-XX-WT-XX-MKT.SLDDRW

PROPRIETARY NOTE
THIS DOCUMENT CONTAINS INFORMATION
CONFIDENTIAL AND PROPRIETARY TO
SAMTEC, INC. AND SHALL NOT BE REPRODUCED
OR TRANSFERRED TO OTHER DOCUMENTS OR
DISCLOSED TO OTHERS OR USED FOR ANY
PURPOSE OTHER THAN THAT WHICH IT WAS
OBTAINED WITHOUT THE EXPRESSED WRITTEN
CONSENT OF SAMTEC, INC.

DO NOT SCALE DRAWING

SHEET SCALE: 10:1



520 PARK EAST BLVD, NEW ALBANY, IN 47150
PHONE: 812-944-6733 FAX: 812-948-5047
e-Mail: info@SAMTEC.com code: 55322

DESCRIPTION:
ZERO INSERTION FORCE 1mm ASSEMBLY

DWG. NO. **ZF1-XX-XX-XX-WT-XX**

BY: KEVIN B 9/20/2002 SHEET 2 OF 4

FIG 2
 * -03 LEAD STYLE
 (SAME AS FIG 1, UNLESS OTHERWISE STATED)
 (ZF1-10-03-T-WT SHOWN)

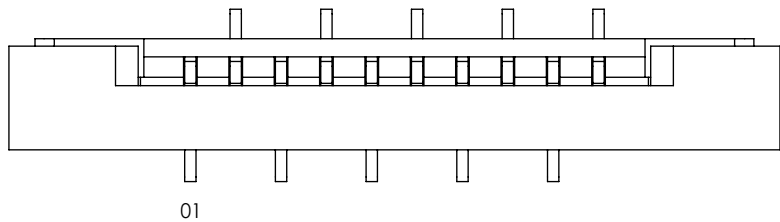

01

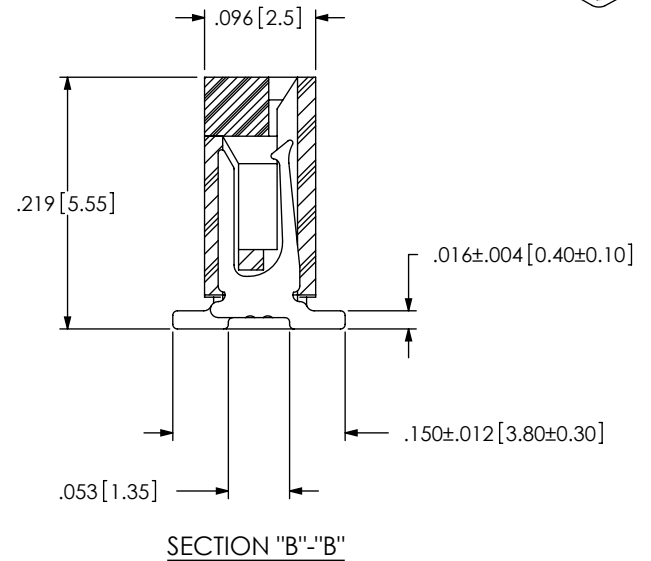
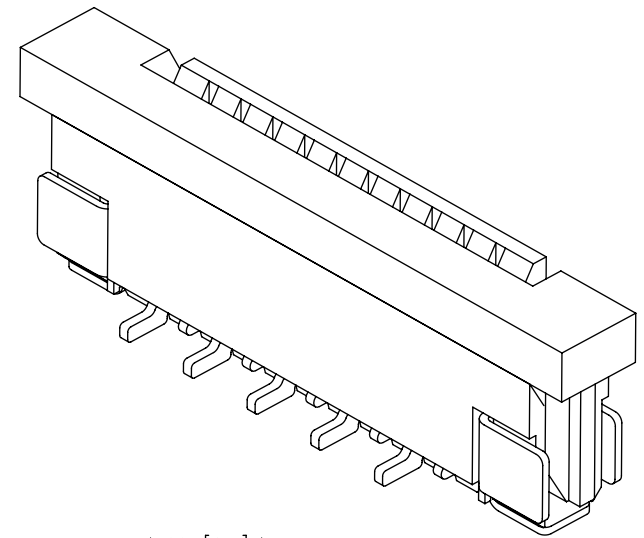
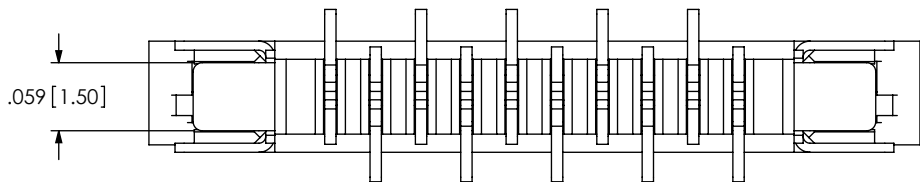
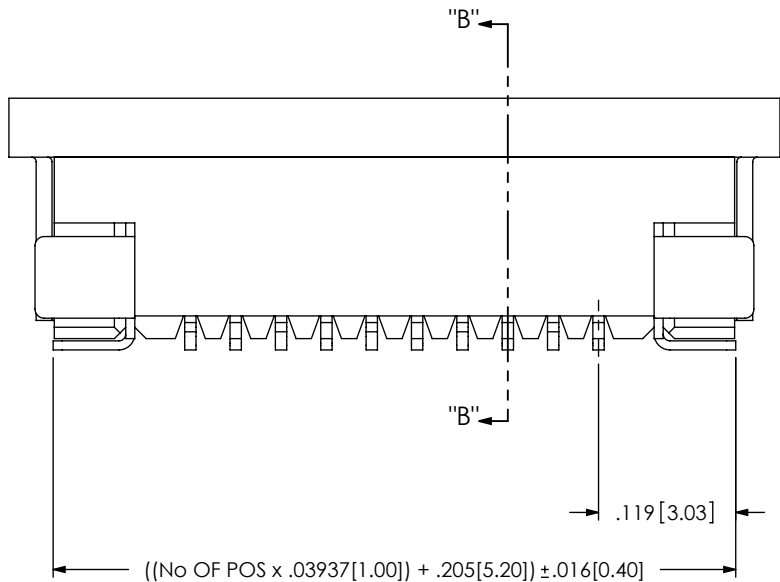

F:\DWG\MISC\MKTG\ZF1-XX-XX-XX-WT-XX-MKT.SLDDRW

PROPRIETARY NOTE
 THIS DOCUMENT CONTAINS INFORMATION
 CONFIDENTIAL AND PROPRIETARY TO
 SAMTEC, INC. AND SHALL NOT BE REPRODUCED
 OR TRANSFERRED TO OTHER DOCUMENTS OR
 DISCLOSED TO OTHERS OR USED FOR ANY
 PURPOSE OTHER THAN THAT WHICH IT WAS
 OBTAINED WITHOUT THE EXPRESSED WRITTEN
 CONSENT OF SAMTEC, INC.

DO NOT SCALE DRAWING

SHEET SCALE: 6:1



520 PARK EAST BLVD, NEW ALBANY, IN 47150
 PHONE: 812-944-6733 FAX: 812-948-5047
 e-Mail: info@SAMTEC.com code: 55322

DESCRIPTION:
 ZERO INSERTION FORCE 1mm ASSEMBLY

DWG. NO.
 ZF1-XX-XX-XX-WT-XX

BY: KEVIN B 9/20/2002 SHEET 3 OF 4

FIG 3
-TR OPTION

-01 LEAD STYLE

NOTE: POS 1 CLOSEST TO ROUND HOLES

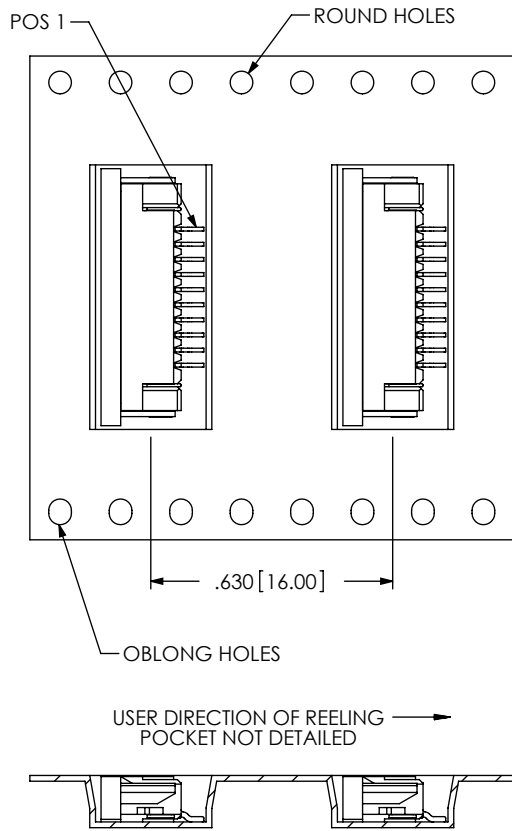

-02 LEAD STYLE

NOTE: POS 1 CLOSEST TO OBLONG HOLES

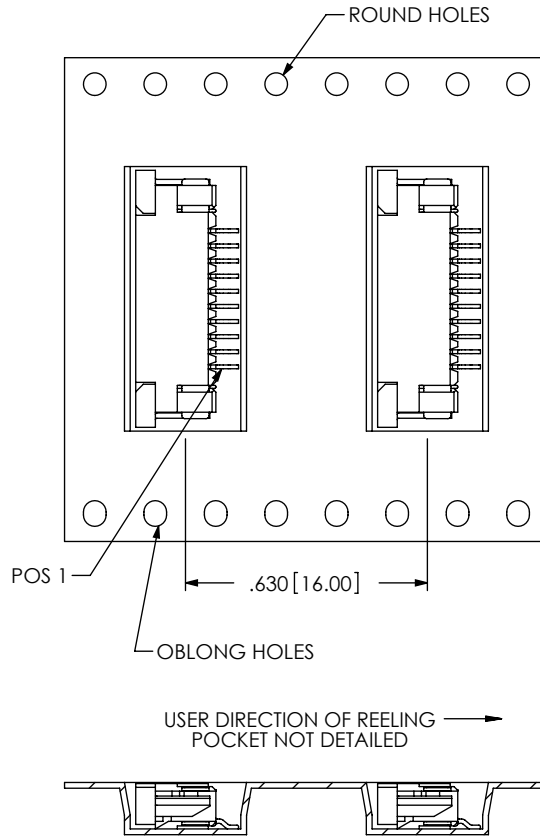

-03 LEAD STYLE

NOTE: POS 1 CLOSEST TO ROUND HOLES

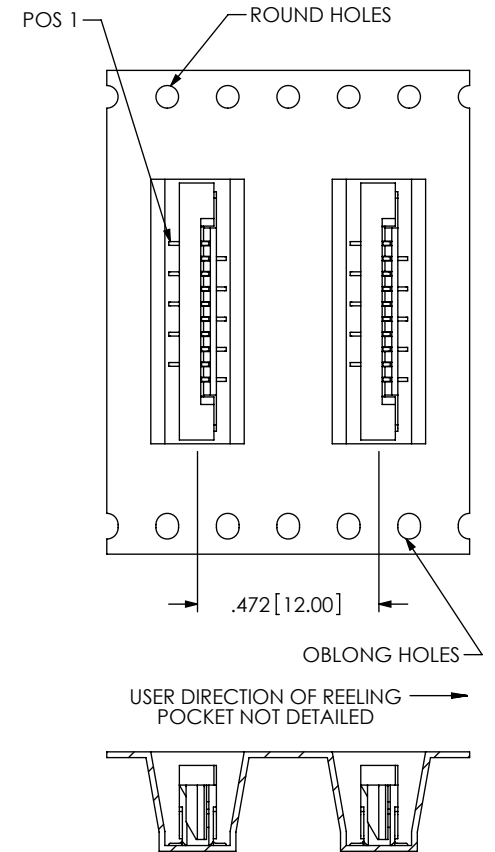

F:\DWG\MISC\MKTG\ZF1-XX-XX-XX-WT-XX-MKT.SLDDRW

PROPRIETARY NOTE

THIS DOCUMENT CONTAINS INFORMATION CONFIDENTIAL AND PROPRIETARY TO SAMTEC, INC. AND SHALL NOT BE REPRODUCED OR TRANSFERRED TO OTHER DOCUMENTS OR DISCLOSED TO OTHERS OR USED FOR ANY PURPOSE OTHER THAN THAT WHICH IT WAS OBTAINED WITHOUT THE EXPRESSED WRITTEN CONSENT OF SAMTEC, INC.

SHEET SCALE: 2:1



520 PARK EAST BLVD, NEW ALBANY, IN 47150
PHONE: 812-944-6733 FAX: 812-948-5047
e-Mail: info@SAMTEC.com code: 55322

DESCRIPTION:
ZERO INSERTION FORCE 1mm ASSEMBLY

DWG. NO. ZF1-XX-XX-XX-WT-XX

BY: KEVIN B 9/20/2002 SHEET 4 OF 4